

Operating instructions and spare parts list

Manual coating equipment OptiFlex L

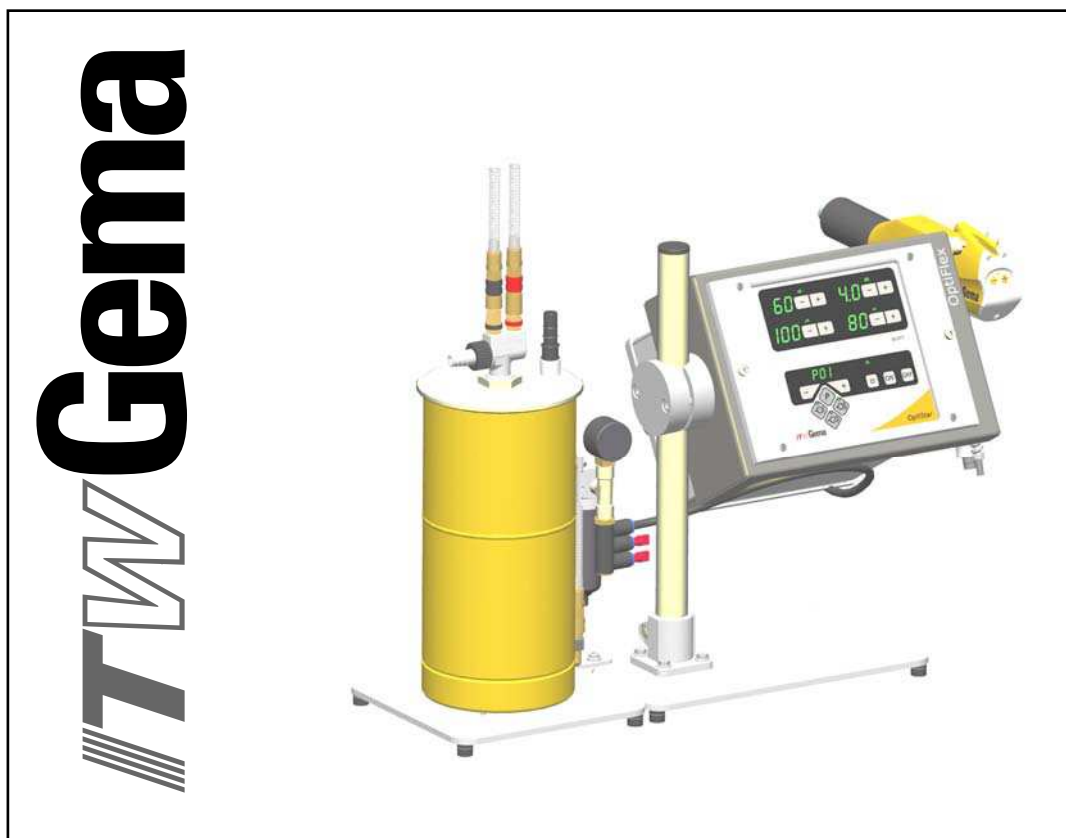

Translation of the original operating instructions

Documentation OptiFlex L manual coating equipment

© Copyright 2005 ITW Gema GmbH

All rights reserved.

This publication is protected by copyright. Unauthorized copying is prohibited by law. No part of this publication may be reproduced, photocopied, translated, stored on a retrieval system or transmitted in any form or by any means for any purpose, neither as a whole nor partially, without the express written consent of ITW Gema GmbH.

OptiTronic, OptiGun, EasyTronic, EasySelect, OptiFlow and SuperCorona are registered trademarks of ITW Gema GmbH.

OptiMatic, OptiMove, OptiMaster, OptiPlus, MultiTronic and Gematic are trademarks of ITW Gema GmbH.

All other product names are trademarks or registered trademarks of their respective holders.

Reference is made in this manual to different trademarks or registered trademarks. Such references do not mean that the manufacturers concerned approve of or are bound in any form by this manual. We have endeavored to retain the preferred spelling of the trademarks, and registered trademarks of the copyright holders.

To the best of our knowledge and belief, the information contained in this publication was correct and valid on the date of issue. ITW Gema GmbH makes no representations or warranties with respect to the contents or use of this publication, and reserves the right to revise this publication and make changes to its content without prior notice.

Printed in Switzerland

ITW Gema GmbH
Mövenstrasse 17
9015 St. Gallen
Switzerland

Phone: +41-71-313 83 00
Fax.: +41-71-313 83 83

E-Mail: info@itwgema.ch
Homepage: www.itwgema.ch

Table of contents

General safety regulations	3
Safety symbols (pictograms).....	3
Conformity of use.....	3
Technical safety regulations for stationary electrostatic powder spraying equipment	4
General information	4
Safety conscious working	5
Individual safety regulations for the operating firm and/or operating personnel	5
Notes on special types of hazard.....	6
Safety requirements for electrostatic powder coating.....	7
A summary of the rules and regulations	8
Product specific security measures	10
About this manual	11
General information	11
Function description	13
Field of application	13
Typical characteristics.....	13
OptiFlex L manual coating equipment	14
Structure.....	14
OptiStar control unit	14
OptiSelect manual powder gun.....	14
OptiFlow injector	14
Fluidized powder hopper.....	14
Scope of delivery	16
OptiFlex 1-L.....	16
Technical data	17
OptiFlex L manual coating equipment	17
Electrical data	17
Pneumactical data	17
Connectable guns	18
Dimensions	18
Start-up and operation	19
Connection guide	19
Preparation for start-up	20
Prepare the fluidized powder hopper.....	20
Switch on the booth	20
Start-up	21
Switch on the control unit.....	21

Color change	23
General information	23
Maintenance and cleaning	25
Daily maintenance	25
Weekly maintenance	25
If in disuse for several days	25
Powder hose rinsing	25
Cleaning	26
Cleaning the powder hopper	26
Cleaning the OptiSelect manual powder gun	26
Maintenance and cleaning of the filter unit	27
Replacing the filter element	27
Troubleshooting	29
General information	29
Schematic diagrams	31
Pneumatic diagram - OptiFlex L	31
Spare parts list	33
Ordering spare parts	33
OptiFlex L manual coating equipment - spare part list	34
OptiFlex L manual coating equipment - spare parts	35
OptiFlex L manual coating equipment - spare parts list	36
OptiFlex L manual coating equipment - spare parts	37
OptiFlex L manual coating equipment - powder hopper	38
OptiFlex L manual coating equipment - powder hopper	39
OptiFlex L - filter unit	40

General safety regulations

This chapter sets out the fundamental safety regulations that must be followed by the user and third parties using the OptiFlex L manual coating equipment.

These safety regulations must be read and understood before the OptiFlex L manual coating equipment is used.

Safety symbols (pictograms)

The following warnings with their meanings can be found in the ITW Gema operating instructions. The general safety precautions must also be followed as well as the regulations in the operating instructions.

**DANGER!**

Danger due to live electricity or moving parts. Possible consequences: Death or serious injury

**WARNING!**

Improper use of the equipment could damage the machine or cause it to malfunction. Possible consequences: minor injuries or damage to equipment



**INFORMATION!**

Useful tips and other information

Conformity of use

1. The OptiFlex L manual coating equipment is built to the latest specification and conforms to the recognized technical safety regulations. It is designed for the normal application of powder coating.
2. Any other use is considered as non-conform. The manufacturer is not responsible for damage resulting from improper use of this equipment; the end-user alone is responsible. If the OptiFlex L manual coating equipment is to be used for other purposes or other substances outside of our guidelines then ITW Gema GmbH should be consulted.

3. Observance of the operating, service and maintenance instructions specified by the manufacturer is also part of conformity of use. The OptiFlex L manual coating equipment should only be used, maintained and started up by trained personnel, who are informed about and are familiar with the possible hazards involved.
4. Start-up (i.e. the execution of a particular operation) is forbidden until it has been established that the OptiFlex L manual coating equipment has been set up and wired according to the guidelines for machinery (98/37 EG). EN 60204-1 (machine safety) must also be observed.
5. Unauthorized modifications to OptiFlex L manual coating equipment exempts the manufacturer from any liability from resulting damage.
6. The relevant accident prevention regulations, as well as other generally recognized safety regulations, occupational health and structural regulations are to be observed.
7. Furthermore the country-specific safety regulations must be observed.

Explosion protection	Protection type	Temperature class
  II (2) D	IP54	T6 (zone 21) T4 (zone 22)

Technical safety regulations for stationary electrostatic powder spraying equipment

General information

The powder spraying equipment from ITW Gema is designed with safety in mind and is built according to the latest technological specifications. This equipment can be dangerous if it is not used for its specified purpose. Consequently it should be noted that there exists a danger to life and limb of the user or third party, a danger of damage to the equipment and other machinery belonging to the user and a hazard to the efficient operation of the equipment.

1. The powder spraying equipment should only be started up and used once the operating instructions have been carefully studied. Improper use of the controlling device can lead to accidents, malfunction or damage to the control itself.
2. Before every start-up check the equipment for operational safety (regular servicing is essential)!
3. Safety regulations BGI 764 and VDE regulations DIN VDE 0147, Part 1, must be observed for safe operation.
4. Safety precautions specified by local legislation must be observed.
5. The plug must be disconnected before the machine is opened for repair.
6. The plug and socket connection between the powder spraying equipment and the mains network should only be taken out when the power is switched off.

7. The connecting cable between the controlling device and the spray gun must be set up so that it cannot be damaged during operation. Safety precautions specified by local legislation must be observed!
8. Only original ITW-Gema spare parts should be used, because the explosion protection will also be preserved that way. Damage caused by other parts is not covered by guarantee.
9. If ITW-Gema powder spraying equipment is used in conjunction with machinery from other manufacturers then their safety regulations must also be taken into account.
10. Before starting work familiarize yourself with all installations and operating elements, as well as with their functions! Familiarization during operation is too late!
11. Caution must be exercised when working with a powder/air mixture! A powder/air mixture in the right concentration is flammable! Smoking is forbidden in the entire plant area!
12. As a general rule for all powder spraying installations, persons with pacemakers should never enter high voltage areas or areas with electromagnetic fields. Persons with pacemakers should not enter areas with powder spraying installations!

**WARNING!**

We emphasize that the customer himself is responsible for the safe operation of equipment. ITW-Gema is in no way responsible for any resulting damages!

Safety conscious working

Each person responsible for the assembly, start-up, operation, service and repair of powder spraying equipment must have read and understood the operating instructions and the "Safety regulations"-chapter. The operator must ensure that the user has had the appropriate training for powder spraying equipment and is aware of the possible sources of danger.

The control devices for the spray guns must only be set up and used in zone 22. Only the spray gun should be used in zone 21.

The powder spraying equipment should only be used by trained and authorized personnel. This applies to modifications to the electrical equipment, which should only be carried out by a specialist.

The operating instructions and the necessary closing down procedures must be followed before any work is carried out concerning the set-up, start-up, operation, modification, operating conditions, mode of operation, servicing, inspection or repairs.

The powder spray equipment can be turned off by using the main switch or failing that, the emergency shut-down. Individual components can be turned off during operation by using the appropriate switches.

Individual safety regulations for the operating firm and/or operating personnel

1. Any operating method which will negatively influence the technical safety of the powder spraying equipment is to be avoided.

2. The operator should care about no non-authorized personnel works on the powder spraying equipment (e.g. this also includes using the equipment for non-conform work).
3. For dangerous materials, the employer has to provide an operating instructions manual for specifying the dangers arising for humans and environment by handling dangerous materials, as well as the necessary preventive measures and behavior rules. The operating instructions manual has to be written in an understandable form and in the language of the persons employed, and has to be announced in a suitable place in the working area.
4. The operator is under obligation to check the powder spraying equipment at least once every shift for signs of external damage, defects or changes (including the operating characteristics) which could influence safety and to report them immediately.
5. The operator is obliged to check that the powder spraying equipment is only operated when in satisfactory condition.
6. As far as it is necessary, the operating firm must ensure that the operating personnel wear protective clothing (e.g. facemasks).
7. The operating firm must guarantee cleanliness and an overview of the workplace with suitable instructions and checks in and around the powder spraying equipment.
8. No safety devices should be dismantled or put out of operation. If the dismantling of a safety device for set-up, repair or servicing is necessary, reassembly of the safety devices must take place immediately after the maintenance or repair work is finished. The powder spraying device must be turned off while servicing is carried out. The operator must train and commit the responsible personnel to this.
9. Activities such as checking powder fluidization or checking the high-voltage spray gun etc. must be carried out with the powder spraying equipment switched on.

Notes on special types of hazard

Power

It is necessary to refer once more to the danger of life from high-voltage current if the shut-down procedures are not observed. High voltage equipment must not be opened - the plug must first be taken out - otherwise there is danger of electric shock.

Powder

Powder/air mixtures can be ignited by sparks. There must be sufficient ventilation in the powder coating booth. Powder lying on the floor around the powder spraying device is a potentially dangerous source of slipping.

Static charges

Static charges can have the following consequences: Charges to people, electric shocks, sparking. Charging of objects must be avoided - see "Earthing".

Grounding/Earthing

All electricity conducting parts and machinery found in the workplace (according to DIN VDE 0745, part 102) must be earthed 1.5 meters either

side and 2.5 meters around each booth opening. The earthing resistance must amount to maximally 1 MOhm. The resistance must be tested on a regular basis. The condition of the machinery surroundings as well as the suspension gear must ensure that the machinery remains earthed. If the earthing of the machinery includes the suspension arrangements, then these must constantly be kept clean in order to guarantee the necessary conductivity. The appropriate measuring devices must be kept ready in the workplace in order to check the earthing.

Compressed air

When there are longer pauses or stand-still times between working, the powder spraying equipment should be drained of compressed air. There is a danger of injury when pneumatic hoses are damaged and from the uncontrolled release and improper use of compressed air.

Crushing and cutting

During operation, moving parts may automatically start to move in the operating area. It must be ensured that only instructed and trained personnel go near these parts. The operator should ensure that barriers comply with the local security regulations.

Access under exceptional circumstances

The operating firm must ensure that local conditions are met when repairs are made to the electronic parts or when the equipment is restarted so that there are additional measures such as barriers to prevent unauthorized access.

Prohibition of unauthorized conversions and modifications to machines

All unauthorized conversions and modifications to electrostatic spraying equipment are forbidden for safety reasons.

The powder spraying equipment should not be used if damaged, the faulty part must be immediately replaced or repaired. Only original ITW-Gema replacement parts should be used. Damage caused by other parts is not covered by guarantee.

Repairs must only be carried out by specialists or in ITW-Gema workshops. Unauthorized conversions and modifications may lead to injury or damage to machinery. The ITW Gema GmbH guarantee would no longer be valid.

Safety requirements for electrostatic powder coating

1. This equipment is dangerous if the instructions in this operating manual are not followed.
2. All electrostatic conductive parts, in particular the machinery within 5 meters of the coating equipment, must be earthed.
3. The floor of the coating area must conduct electricity (normal concrete is generally conductive).
4. The operating personnel must wear electricity conducting footwear (e.g. leather soles).
5. The operating personnel should hold the gun with bare hands. If gloves are worn, these must also conduct electricity.

6. The supplied earthing cable (green/yellow) must be connected to the earthing screw of the electrostatic powder spraying hand appliance. The earthing cable must have a good metallic connection with the coating booth, the recovery unit and the conveyor chain and with the suspension arrangement of the objects.
7. The electricity and powder supply to the hand guns must be set up so that they are fully protected against heat and chemical damage.
8. The powder coating device may only be switched on once the booth has been started up. If the booth cuts out then the powder coating device must be switched off.
9. The earthing of all electricity conducting devices (e.g. hooks, conveyor chains) must be checked on a weekly basis. The earthing resistance must amount to maximally 1 MOhm.
10. The control device must be switched off if the hand gun is cleaned or the nozzle is changed.
11. When working with cleaning agents there may be a risk of hazardous fumes. The manufacturers instructions must be observed when using such cleaning agents.
12. The manufacturers instructions and the applicable environmental requirements must be observed when disposing of powder lacquer and cleaning agents.
13. If any part of the spray gun is damaged (broken parts, tears) or missing then it should not be used.
14. For your own safety, only use accessories and attachments listed in the operating instructions. The use of other parts can lead to risk of injury. Only original ITW-Gema replacement parts should be used.
15. Repairs must only be carried out by specialists and under no circumstances should they be carried out in the operating area. The former protection must not be reduced.
16. Conditions leading to dangerous levels of dust concentration in the powder spraying booths or in the powder spraying areas must be avoided. There must be sufficient technical ventilation available, to prevent a dust concentration of more than 50% of the lower explosion limit (UEG) (UEG = max. permissible powder/air concentration). If the UEG is not known then a value of 10 g/m³ should be used.

A summary of the rules and regulations

The following is a list of relevant rules and regulations which are to be observed:

Guidelines and regulations, German professional association

BGV A1	General regulations
BGV A2	Electrical equipment and material
BGI 764	Electrostatic coating
BGR 132	Guidelines for the avoidance of the dangers of ignition due to electrostatic charging (Guideline "Static Electricity")

VDMA 24371	Guidelines for electrostatic coating with synthetic powder ¹⁾ - Part 1 General requirements - Part 2 Examples of use
------------	---

EN European standards

RL94/9/EC	The approximation of the laws of the Member States relating to apparatus and safety systems for their intended use in potentially explosive atmospheres
EN 292-1 EN 292-2	Machine safety ²⁾
EN 50 014 to EN 50 020, identical: DIN VDE 0170/0171	Electrical equipment for locations where there is danger of explosion ³⁾
EN 50 050	Electrical apparatus for potentially explosive atmospheres - Electrostatic hand-held spraying equipment ²⁾
EN 50 053, part 2	Requirements for the selection, installation and use of electrostatic spraying equipment for flammable materials - Hand-held electrostatic powder spray guns ²⁾
EN 50 177	Stationary electrostatic spraying equipment for flammable coating powder ²⁾
PR EN 12981	Coating plants - Spray booths for application of organic powder coating material - Safety requirements
EN 60 529, identical: DIN 40050	IP-Type protection: contact, foreign bodies and water protection for electrical equipment ²⁾
EN 60 204 identical: DIN VDE 0113	VDE regulations for the setting up of high-voltage electrical machine tools and processing machines with mains voltages up to 1000 V ³⁾

VDE (Association of German Engineers) Regulations

DIN VDE 0100	Regulations for setting-up high voltage equipment with mains voltages up to 1000V ⁴⁾
DIN VDE 0105 part 1 part 4	VDE regulations for the operation of high voltage equipment ⁴⁾ General regulations Supplementary definitions for stationary electrical spraying equipment
DIN VDE 0147 part 1	Setting up stationary electrostatic spraying equipment ⁴⁾
DIN VDE 0165	Setting up electrical equipment in locations in areas with danger of explosion ⁴⁾

*Sources:

- 1) Carl Heymanns Verlag KG, Luxemburger Strasse 449, 5000 Köln 41, or from the appropriate employers association
- 2) Beuth Verlag GmbH, Burggrafenstrasse 4, 1000 Berlin 30
- 3) General secretariat, Rue Bréderode 2, B-1000 Bruxelles, or the appropriate national committee
- 4) VDE Verlag GmbH, Bismarckstrasse 33, 1000 Berlin 12

Product specific security measures

- The installation work, to be done by the customer, must be carried out according to local regulations
- Before starting up the plant a check must be made that no foreign objects are in the booth or in the ducting (input and exhaust air)
- It must be observed, that all components are grounded according to the local regulations, before start-up

About this manual

General information

This operating manual contains all the important information which you require for the working with the OptiFlex L manual coating equipment. It will safely guide you through the start-up process and give you references and tips for the optimal use of your new powder coating system.

Information about the function mode of the individual system components - booth, gun control unit, manual gun or powder injector - should be referenced to their enclosed corresponding documents.

Function description

Field of application

The OptiFlex L manual coating equipment (with fluidized powder hopper) is designed exclusively for electrostatic coating with organic powders. Any other use is considered as non-conform. The manufacturer is not responsible for any damage resulting from this, the risk for this is assumed by the user alone!

The OptiFlex L electrostatic powder manual coating equipment with the OptiSelect manual powder gun is ideally suited for manual coating of objects in vary small series, for test coatings at powder manufacturers, and in test laboratories

Typical characteristics

- Processing the powder from the fluidized powder hopper
- Quick and simple color change
- Supplied ready for use
- Available with one or two guns (extensible)

OptiFlex L manual coating equipment

Structure

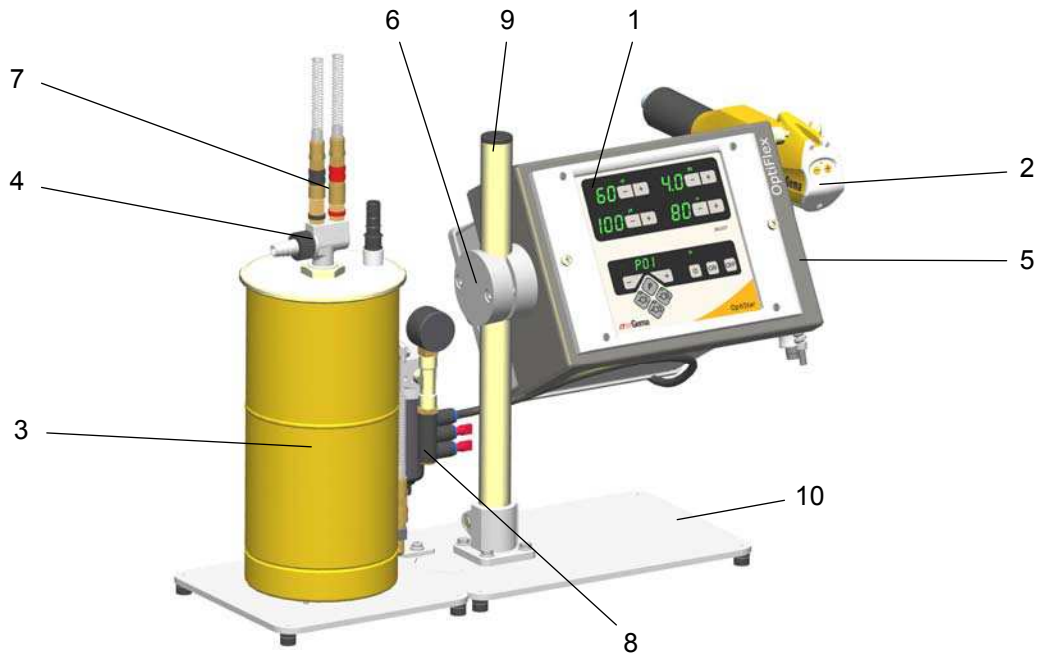

OptiFlex L manual coating equipment - structure

- | | | | |
|---|------------------------------|----|----------------------|
| 1 | OptiStar control unit | 6 | Clamping element |
| 2 | OptiSelect manual powder gun | 7 | Pneumatic connection |
| 3 | Powder container | 8 | Filter unit |
| 4 | Injector | 9 | Tube |
| 5 | Rack | 10 | Base |

OptiStar control unit

All information about the OptiStar control unit will be found in the corresponding enclosed documentation!

OptiSelect manual powder gun

All information about the OptiSelect manual powder gun will be found in the corresponding enclosed documentation!

OptiFlow injector

All information about the OptiFlow injector will be found in the corresponding enclosed documentation!

Fluidized powder hopper

The fluidized powder in the powder hopper is sucked into the injector by means of the conveying air (1, red hose). The powder/air mixture reaches

the powder gun through the powder hose (2). The powder is electrostatically charged at the nozzle of the gun. In addition, an electrostatic field is created between the gun nozzle and the grounded object. The charged powder spray remains adhered to the surface of the object.

The powder is fluidized by air forced through a porous plastic plate from below. The powder acquires, thereby, fluid-like characteristics.

The conveying air, supplementary air, and rinsing air are set on the control unit.

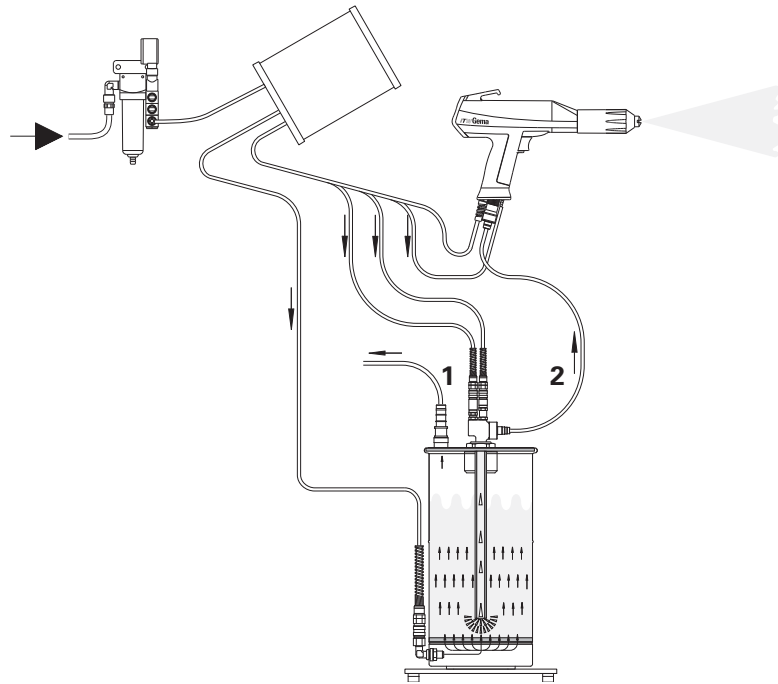

Fluidized powder hopper - function

Scope of delivery

OptiFlex 1-L

- A OptiStar control unit in a metal case with power supply cable
- A base with column and filter unit
- A fluidized powder hopper
- A plug-in OptiFlow injector
- An OptiSelect manual powder gun with gun cable, powder hose, rinsing air hose and standard nozzle set (see therefore the OptiSelect manual powder gun user manual)
- Pneumatic hoses for conveying air (red), supplementary air (black) and fluidizing air (black)

Technical data

OptiFlex L manual coating equipment

Electrical data

OptiFlex L	
Mains input voltage	100-240 VAC
Operating frequency	50/60 Hz
Input power	40 VA
Nominal output voltage (to the gun)	max. 12 V
Nominal output current (to the gun)	max. 1 A
Protection type	IP54
Temperature range	0-40°C (+32 °F - +104 °F)
Approval	(pendent)

Pneumatical data

OptiFlex L	
Compressed air main connection	G1/4" - female thread
Max. input pressure	10 bar
Min. input pressure (while unit in operation)	6 bar
Max. water vapor content of the compressed air	1,3 g/m ³
Max. oil vapor content of the compressed air	0,1 mg/m ³
Max. compressed air consumption	8 m ³ /h

Connectable guns

OptiFlex L	connectable
OptiSelect GM02	yes
OptiGun GA02	yes
PG1/PG2-A	yes (no remote control)
TriboJet	yes, with adapter*

* The gun type must be set on the control unit (see therefore the corresponding user manual)!



Attention:
The OptiFlex L manual coating equipment can only be used with the specified gun types!

Dimensions

OptiFlex L	
Width	654 mm
Depth	310 mm
Height	428 mm
Weight	16,5 kg

Start-up and operation

Connection guide

1. Check the compressed air connection from the filter unit to the control unit. Connect the compressed air supply hose from the compressed air circuit directly to the filter unit main connection on the rear side of the equipment (1/4" female BSP)



Note:

The compressed air must be free from oil and water!

2. Connect the black hose for fluidizing air (electrically conductive) to the output **1.5** on the rear side of the control unit
3. Connect the grounding cable to the control unit with the grounding screw, and the 5 m long grounding cable with the clamping clip to the booth or the conveyor. Check ground connections with Ohm meter and ensure 1 MOhm or less
4. Connect the gun cable plug to the socket **2.3** on the rear side of the control unit
5. Connect the rinsing air hose to the electrode rinsing air output **1.4** and to the powder gun
6. Attach the injector, connect the powder hose to the injector and to the powder gun
7. Connect the red hose for the conveying air to the corresponding output **1.2** on the rear of the control unit and to the injector
8. Connect the black hose for supplementary air to the corresponding output **1.3** on the rear side of the control unit and to the injector (this hose is electrically conductive)
9. Connect the mains cable to the **2.1 Power IN** plug and screw it on



Note:

Close the 2.2 Aux output with the provided dust protection cap!

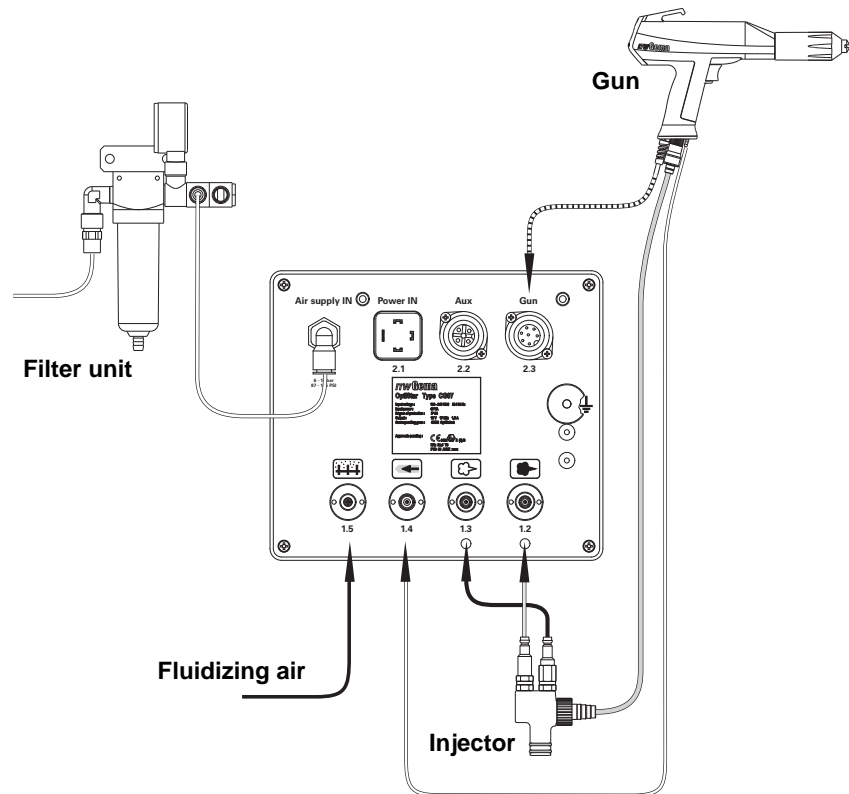

Connecting guide - overview

Preparation for start-up

Prepare the fluidized powder hopper

1. Release the clamp ring holding the cover, and lift off (complete with the injector, and the venting hose) from the powder hopper. Take care that the suction tube is not damaged!
2. Fill the hopper with max. 2 dm³ (2 liters) of powder. Do not overfill, because the fluidized powder can escape from the cover
3. Carefully replace the cover and refasten the clamp ring
4. Adjust the fluidization on the control unit (see also the OptiStar CG07 control unit operating instructions, chapter "Setting the fluidizing")

Switch on the booth

The coating booth is switched on according to the corresponding user manual.

Start-up

Switch on the control unit

1. Press the **ON** power switch.
The displays illuminate and the control unit is ready for operation



Note:

The further start-up procedure for the OptiFlex B manual coating equipment is explicitly described in the OptiStar CG07 control unit operating instructions (chapter "Initial start-up" and "Daily start-up")!

Color change

General information

When a color change takes place, the individual components of the manual coating equipment must be cleaned carefully. Thereby, all powder particles of the former color must be removed!

Procedure:

1. Empty the powder hopper and clean thoroughly
2. Clean the powder hose:
 - Strip the powder hose from the hose connection on the injector
 - Point the gun into the booth
 - Blow through the hose manually with a compressed air gun
 - Fit the powder hose again to the hose connection on the injector
3. Dismantle and clean the powder gun (see therefore the user manual of the OptiSelect manual powder gun)
4. Clean the injector (see therefore the user manual of the OptiFlow injector)
5. Prepare the manual coating equipment with new powder for start-up

Maintenance and cleaning



Note:

Regular and conscientious maintenance increases the life span of the manual coating equipment and provides for a longer continuous coating quality!

Daily maintenance

1. Clean the injector (see therefore the user manual of the OptiFlow injector)
2. Clean the powder gun (see therefore the user manual of the OptiSelect manual powder gun)
3. Clean the powder hose, see therefore in chapter "Color change"

Weekly maintenance

1. Clean the powder hopper, injector and powder gun
2. Check the control unit grounding connections to the coating booth, the suspension devices of the work pieces, or the conveyor chain

If in disuse for several days

1. Remove the mains plug
2. Clean the coating equipment
3. Turn off the compressed air main supply

Powder hose rinsing

If lengthy downtimes take place, the powder hose must be cleaned.

Procedure:

1. Strip the powder hose from the hose connection on the injector
2. Point the gun into the booth
3. Blow through the hose manually with a compressed air gun
4. Fit the powder hose again to the hose connection on the injector

Cleaning

Cleaning the powder hopper

1. Disconnect the fluidizing air supply
2. Remove the injector
3. Remove the cover, blow out with compressed air and clean with a clean dry brush and cloth
4. Clean the suction tube, and injector
5. Empty the remaining powder into a container
6. Vacuum the hopper and, above all, the floor of the hopper
7. Clean the hopper with a cloth
8. Reassemble the powder hopper



Note:

Refill the powder hopper shortly before reusing! Never clean the powder hopper with solvents or water!

Cleaning the OptiSelect manual powder gun

Frequent cleaning of the gun helps to guarantee the coating quality.



Note:

Before cleaning the powder gun, switch off its control unit. The compressed air used for cleaning must be free from oil and water!

Daily:

1. Blow off the outside of the gun and wipe, clean etc.

Weekly:

2. Remove the powder hose from the connection
3. Remove the spray nozzle from the gun and clean it
4. Blow out the gun from the connection in flow direction with compressed air
5. Clean the integrated gun tube with the provided gun brush
6. Blow through the gun with compressed air again
7. Clean the powder hose
8. Reassemble the gun and connect it



Note:

See therefore the user manual of the OptiSelect manual powder gun!

Maintenance and cleaning of the filter unit

The filter unit on the OptiFlex L manual coating equipment measures and cleans the compressed air. Here, the main compressed air connection of the equipment is located.

Replacing the filter element

Procedure:

1. Unscrew the filter glass on the filter unit
2. Loosen the cap screw
3. Remove the complete filter element
4. Replace the filter element
5. Clean the filter glass on the inside and install it again

Troubleshooting

General information

Fault	Causes	Troubleshooting
---	Power pack defective	Replace the power pack, if error is permanent
---	Main valve defective	Replace main valve coil
---	Gun not connected Gun plug, gun cable or gun cable connection defective Remote control on powder gun defective	Connect the gun Replace corresponding part or send in for repair Replace remote control (gun back cover)
---	Rinsing air solenoid valve of flat jet nozzle defective	Replace valve coil
---	Rinsing air solenoid valve of round jet nozzle defective	Replace valve coil
---	Gun plug, gun cable or gun cable connection defective	Replace corresponding part or send in for repair
Gun LED remains dark, although the gun is triggered	Gun plug, gun cable or gun cable connection defective Remote control on powder gun defective	Replace corresponding part or send in for repair Replace remote control (gun back cover)
Powder does not adhere to object, although the gun is triggered and sprays powder	High voltage and current deactivated High voltage cascade defective Objects are not properly grounded	Press the selection key (application key) Send in the gun for repair Check the grounding

Fault	Causes	Troubleshooting
Control unit displays remain dark, although the control unit is switched on	Control unit is not connected to the mains Power pack fuse defective Power pack defective	Connect the equipment with the mains cable Replace the fuse Replace the power pack, if error is permanent
The powder is not fluidized	Compressed air not present Fluidizing air is set too low on the control unit Throttle motor defective	Connect the equipment to the compressed air Set the fluidizing air correctly Replace throttle motor
The gun does not spray powder, although the control unit is switched on and the gun is triggered	Compressed air not present Injector, throttle motor or nozzle on injector, powder hose or powder gun are clogged Nozzle in the injector is clogged Nozzle is not inserted Fluidizing not running No conveying air: Throttle motor defective Solenoid valve defective Front plate defective	Connect the equipment to the compressed air Clean corresponding part Replace Insert the insert sleeve (see above) Replace the throttle motor Replace the solenoid valve Send in for repair

Schematic diagrams

Pneumatic diagram - OptiFlex L

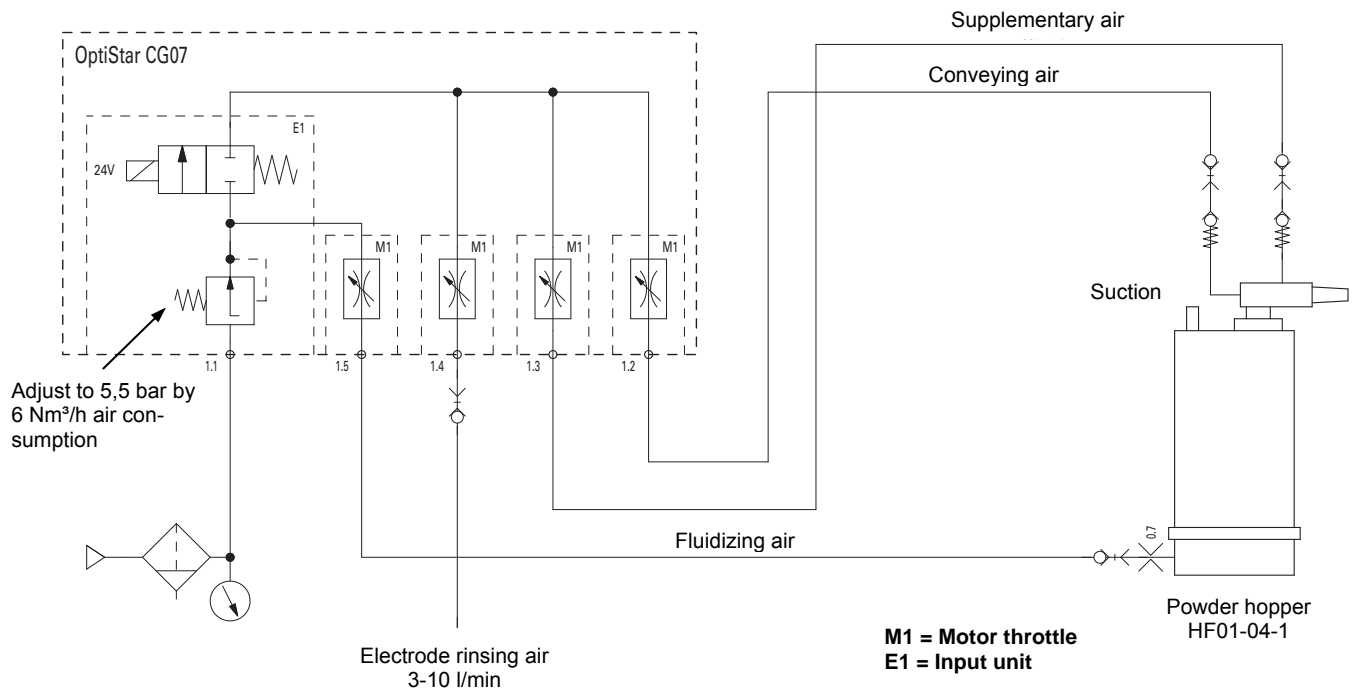

Pneumatic diagram - OptiFlex L

Spare parts list

Ordering spare parts

When ordering spare parts for powder coating equipment, please indicate the following specifications:

- Type and serial number of your powder coating equipment
- Order number, quantity and description of each spare part

Example:

- **Type** OptiFlex L manual coating equipment,
Serial no. 1234 5678
- **Order no.** 203 386, 1 piece, Clamp - Ø 18/15 mm

When ordering cable or hose material, the required length must also be given. The spare part numbers of this yard/meter ware is always marked with an *.

The wear parts are always marked with a #.

All dimensions of plastic hoses are specified with the external and internal diameter:

Example:

Ø 8/6 mm, 8 mm outside diameter (o/d) / 6 mm inside diameter (i/d)



WARNING!

Only original ITW-Gema spare parts should be used, because the explosion protection will also be preserved that way. The use of spare parts from other manufacturers will invalidate the ITW Gema guarantee conditions!

OptiFlex L manual coating equipment - spare part list

1	Base complete	385 190
2	Filter unit - complete (see corresponding spare parts list)	
3	CG07 gun control unit - complete (see corresponding operating manual)	
4	Powder hopper - complete (see corresponding spare parts list)	
5	OptiSelect manual powder gun - complete (see corresponding operating manual)	
6	Column - complete	1002 532
7	Mounting bracket	1002 579
8	Rectus quick release connection - Ø 10 mm, NW7,4 mm	239 267
A	Clamping element 30-1-1 - complete, incl. pos. 9, 10, 11	376 183
9	Cover, fix	364 720
10	Cover	364 010
11	Allen cylinder screw - M8x25 mm	216 500
12	Allen ribbed screw - M6x16 mm	261 823
13	Cleaning brush - Ø 12 mm	389 765
14	Application cup - complete (see corresponding operating manual)	
15	Pneumatic connection - conveying air (complete)	382 213
16	Pneumatic connection - supplementary air (complete)	382 221
23	Pneumatic connection - fluidizing air (complete)	382 230
25	Parts set, consisting of:	1002 016
	Injector nozzle - PTFE	377 724#
	Injector plug gauge	393 380
	O-ring - Ø 16x2 mm	231 517#
	Fuse - F4.00AF	262 897
	Cable tie - L=100x2.5 mm	200 719
26	Rack - complete	1002 680
27	Short instruction OptiStar CG07	1002 060
28	Program table OptiStar CG07	1002 063
32	Hex. Allen key - wrench size 6	262 030
36	Plastic tube - Ø 8/6 mm black	103 152*

Wearing part

* Please indicate length

OptiFlex L manual coating equipment - spare parts

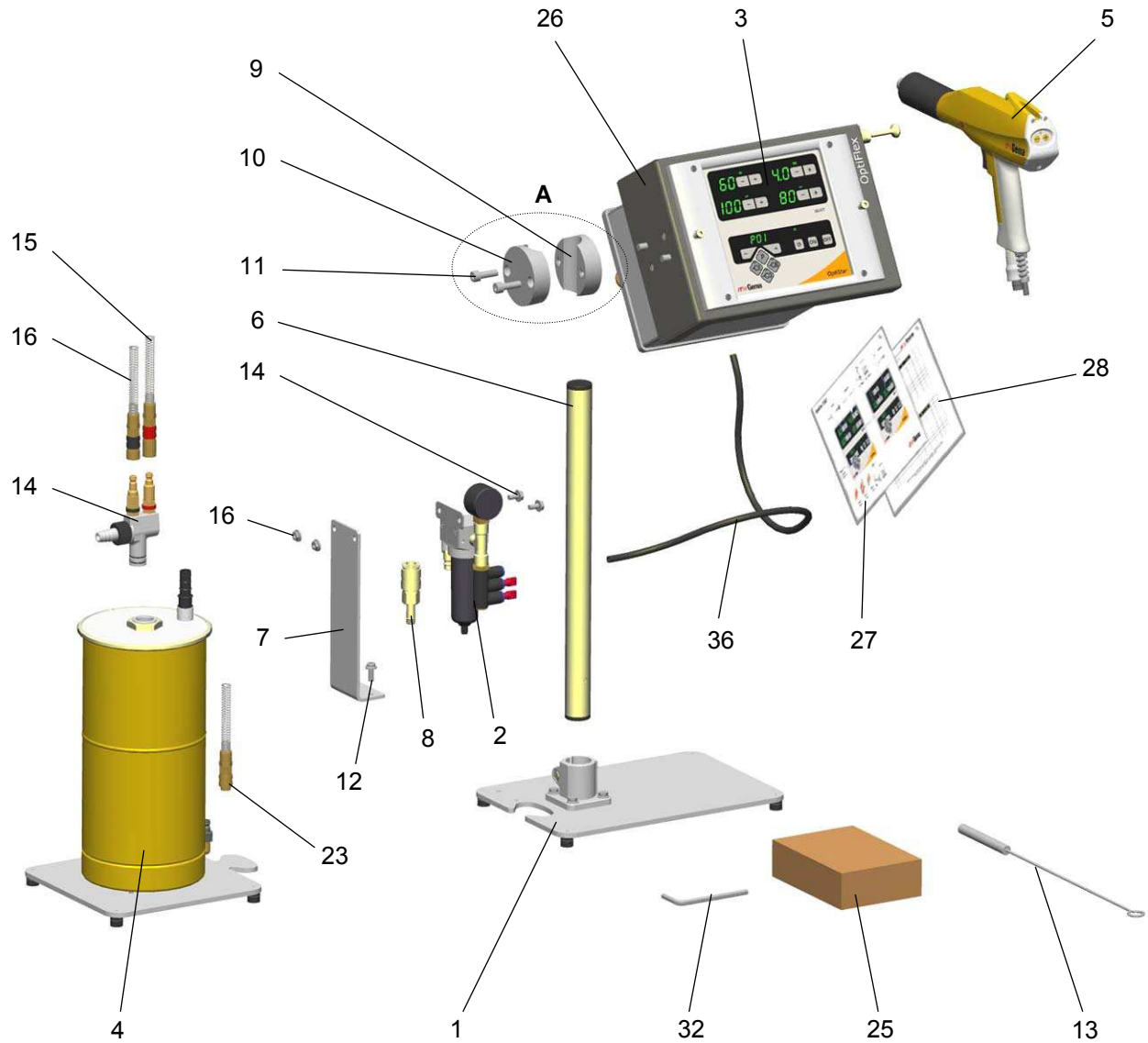

OptiFlex L manual coating equipment - spare parts

OptiFlex L manual coating equipment - spare parts list

1	Gun retainer	1001 140
2	Mains cable - L=5m, 12 G (Switzerland)	382 493
	Mains cable - L=5m, VII G Schuko (Europe, Russia etc.)	382 485
	Mains cable - L=5m, 498 G (USA, Japan etc.)	382 507
	Mains cable - L=5m, BS89/5 (GB, Africa etc.)	382 515
	Mains cable - L=5m, SAA/3 (Australia, China etc.)	382 523
	Pneumatic connection - supplementary air (complete incl. pos. 5, 6 and 7)	382 221
5	Nut with kink protection - M12x1 mm, Ø 8 mm	201 316
6	Hose - Ø 8/6 mm, black	103 756*
7	Quick release connection - NW5-Ø 8 mm, black	261 637
	Pneumatic connection - conveying air (complete incl. pos. 8, 9 and 10)	382 213
8	Quick release connection - NW5-Ø 8 mm, red	261 645
9	Plastic tube - Ø 8/6 mm, antistatic	103 500*
10	Nut with kink protection - M12x1 mm, Ø 8 mm	201 316
11	Grounding cable - complete	301 140
12	Protecting cap	206 474
13	Shakeproof Allen screw - M8x12 mm	263 214
	Pneumatic connection - conveying air (complete, incl. pos. 8, 9 and 10)	382 230
14	Quick release connection - NW5-Ø 8 mm	203 181
15	Hose - Ø 8/6 mm, black	103 756*
16	Nut with kink protection - M12x1 mm, Ø 8 mm	201 316

* Please indicate length

OptiFlex L manual coating equipment - spare parts

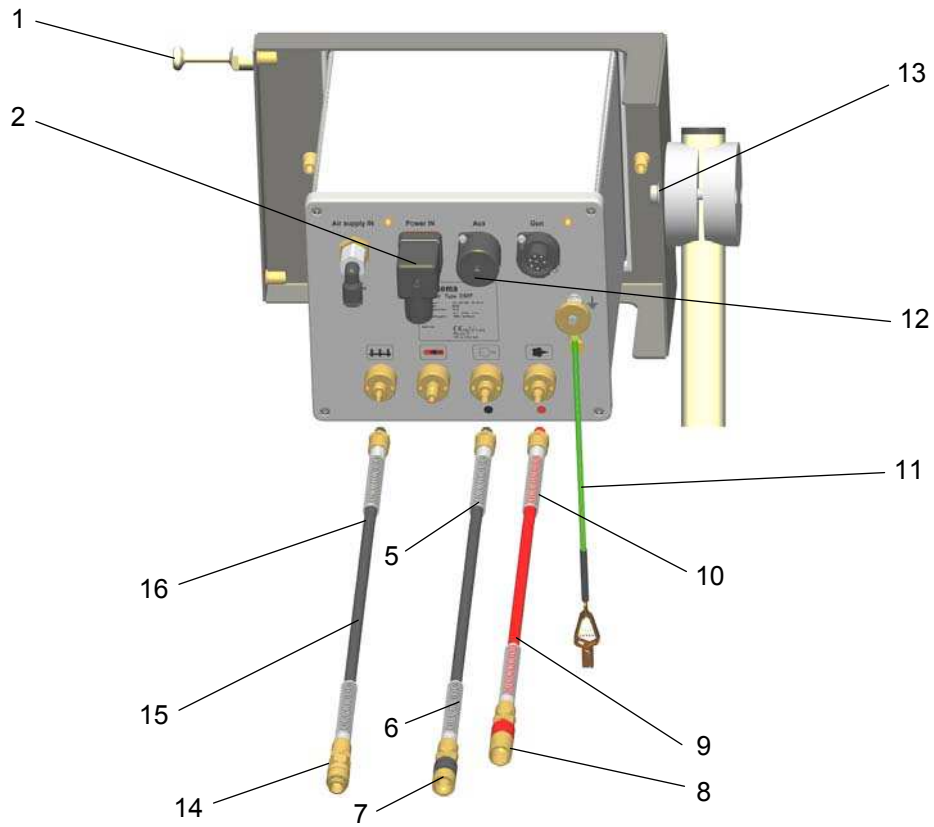

OptiFlex L manual coating equipment - spare parts

OptiFlex L manual coating equipment - powder hopper

Powder hopper - complete (incl. pos. 1-21)		379 441
1	Hopper body	379 484
2	Base plate	379 492
3	Spacing ring	382 191
4	Fluidizing bed	310 468
5	Cover	379 450
6	Suction tube holder - complete (incl. pos. 6.1)	371 890
6.1	O-ring - Ø 28.3x1.78 mm	261 564
7	Suction tube - L=233 mm	371 939
8	Quick-connection socket	379 468
9	Bezel - Ø 0.7 mm	371 904
10	Venting connector - Ø 12 mm	377 988
12	Clamping ring - 160-05	258 237
13	Rubber pad - Ø 15x8 mm, M4/A	234 915
14	O-ring - Ø 15x1.5 mm	261 564
15	Sealing ring - Ø 10.2/17x3.8 mm	230 626
16	Countersunk head screw - M5x16 mm	262 986
17	Lock nut - PG29	262 056
18	Counter nut - PG21	234 869
19	Connector - NW5, 1/8"i	200 859
20	Elbow screw connection - 1/8"a-1/8"a	1001 079
21	Gasket	1003 657

OptiFlex L manual coating equipment - powder hopper

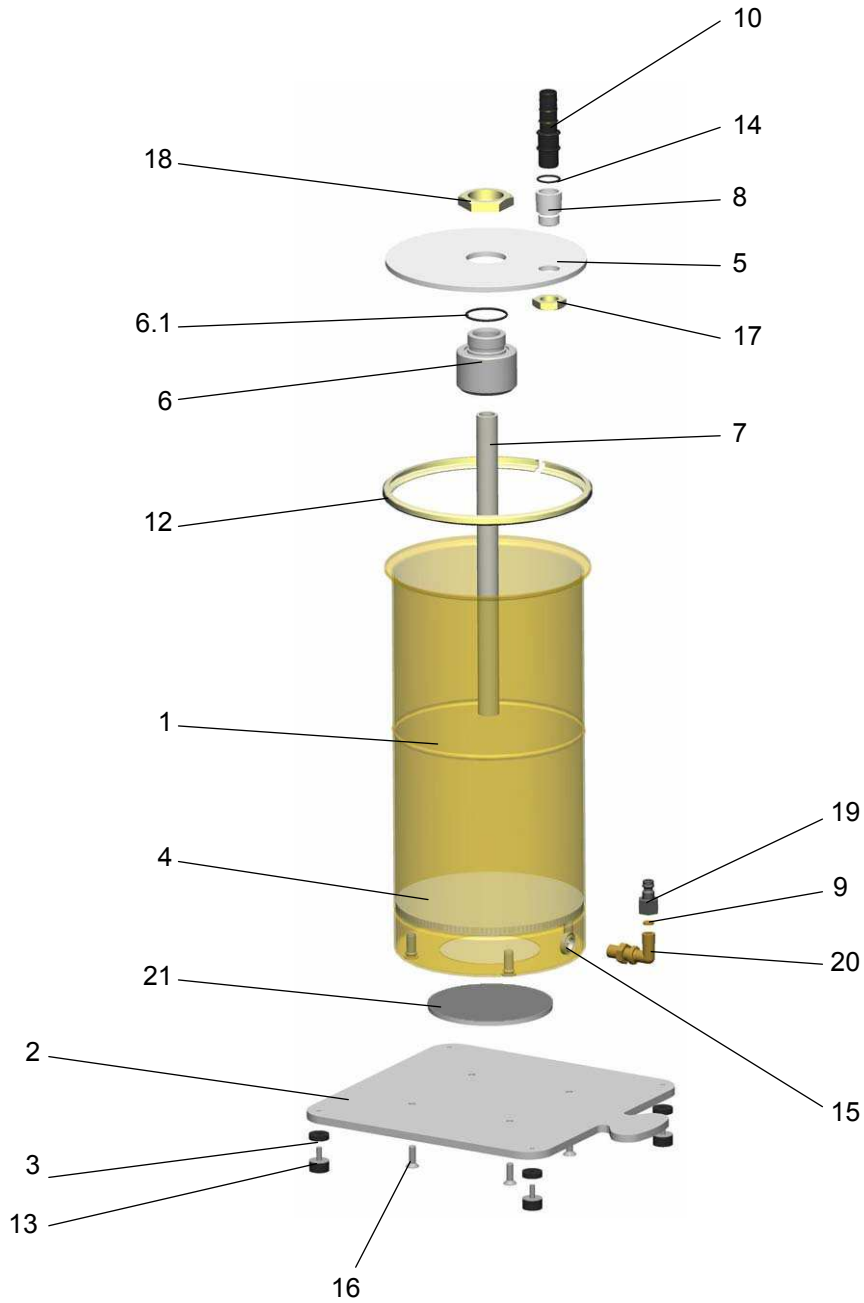

OptiFlex L manual coating equipment - powder hopper

OptiFlex L - filter unit

	Filter unit - complete, without pos. 14	1001 147
1	Filter separator - MAF200L-8A	1007 321
2	T-piece - 1/4"i-1/4"a-1/4"i	262 064
3	Elbow joint - 1/4"-3xØ 8-8 mm	1007 327
7	Filter cartridge - 20 µm	1007 325
9	Manometer - G1/4", 0-10 bar	1007 328
10	Rectus nipple - NW 7.4-1/4"a	256 730
11	Grommet - Ø 8 mm	238 023
12	Elbow joint - 1/4"i-1/4"a	222 674
14	Rectus quick release connection (for pos. 10) - NW 7.8-Ø 10 mm	239 267

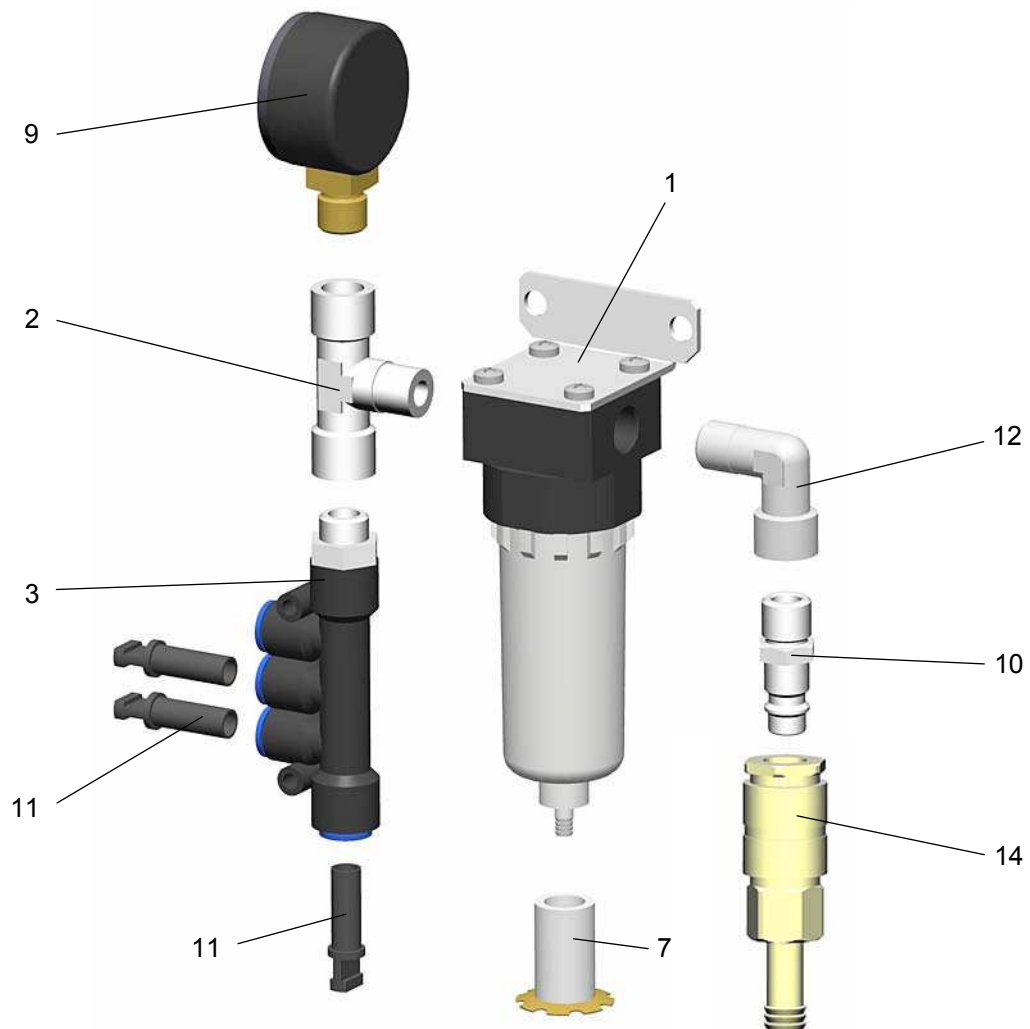

OptiFlex L - filter unit

