

altuS VTR/DDR Edit Controller

Users Manual

Software version: 2.02



History

Date	Description	Version
Oct 2009	altuS manual Version 1.0	1.0
Oct 2012	altuS manual Version 2.0	2.0

altuS VTR and Disk controllers

Hi Tech Systems Ltd
Holbrook House
Oakley Lane
Oakley
Basingstoke
Hampshire RG23 7JY

Tel: +44 (0) 1256 780880
Fax: +44 (0) 1256 782600
Email: support@hitechsys.com
Web: www.hitechsys.com

The hardware/software and manual are copyright 1998 - 2012 by Hi Tech Systems Ltd. All rights reserved. The operating code is licensed by Hi Tech to the original purchaser only. It is not permitted to copy, sell or use this product in any other way than is intended.

All trademarks acknowledged.

According to the U.K. copyright law, unauthorised reproduction of software can be subject to civil damages.

The information in this document is subject to change without notice.

In no event will Hi Tech Systems Ltd be liable for direct, indirect, incidental or consequential damages resulting from any defect in the software even if they have been advised of such damages.

Contents

1 INTRODUCTION	1
2 INSTALLATION	3
Unpacking	3
Desk mounting	3
Warnings – read before installation or use	4
EXTERNAL CONNECTIONS	5
Power requirements	5
Connecting a VTR	6
RJ45 connector pin out	6
3 OPERATION	7
Using the main controller keys	7
How to Jog, shuttle and Var	8
How to crash record	8
How to stop record or playback	8
How to select both VTR channels for group control	8
Editing	9
Keyboard / Keypad Socket	10
Rules to editing with the HT212e	10
Review and Preview.	12
Slo-Motion Recording.	12
Edit delay	13
Start delay	13
Edit Sync	13
Advanced Operations	14
How to clear an in-point and out-point	14
How to clear the memory, and restore to factory default?	14
How to change the timecode source	14
Setting TCG and CTL	16
How to enter and exit the altuS SETUP menu.	17
How to change operational parameters in the SETUP menu	17
MENU OPERATIONAL SETTINGS	18
4 TROUBLE SHOOTING	24
ADDENDUM	25
SUMMARY OF FUNCTIONS	25

altuS VTR and Disk controllers

OUTLINE DIMENSIONS	27
SOFTWARE UPDATES	27
CABLE PIN OUT REFERENCE	28
NOTES ON PC SERIAL CONNECTORS	30
6 SPECIFICATION	32

1 Introduction

The Hi Tech altuS HT212e VTR and DDR edit controller provide a user-friendly remote control interface for professional and broadcast videotape and disk recorders.

The controllers utilise a control wheel, called “**smart χ wheel**” that is our first implementation of Haptic technology – “Haptic” is Greek for the science of touch. Our controller can be programmed to give the operator different tactile and kinesthetic sensations depending on the mode of operation, such as jog, indented incremental shuttle speeds and so on.

altuS edit controller



HT212e

1 Introduction

Accessories supplied:

- 2 RJ45 to 9 pin 'D' type adaptors
- User's manual (this manual) on CD

Available options:

- Spare RJ45 to 9 pin 'D' type adaptor male for direct connection to VTR
- Spare RJ45 to 9 pin 'D' type adaptor female for connection to end of "standard" RS422 cable



In this manual altuS VTR and DDR controller is referred to as 'controller'. VTR, and disk recorders are referred to as 'VTR'.

2 Installation

The Hi Tech Series of VTR Controllers are designed as desk-top units.

Unpacking

The Hi Tech Systems altuS VTR controllers are shipped in a carton, which may contain other optional items within the packing, and care should be taken to ensure that these are not thrown away. The contents of the carton are as indicated on the delivery note. Carefully unpack and check for shipping damage and shortages. Report without delay, any damage or shortages to Hi Tech Systems Ltd.

Desk mounting

The altuS desk mounting controllers require no special fixings, but can be mounted into a desk as a 'drop through' unit.

Outline dimensions for all models are given in the Addendum at the back of this manual.

2 Installation

Warnings – read before installation or use



Only use the 12V adaptor provided with the controller. The 12V PSU is powered with 110V – 240V AC using an IEC mains lead.

Only suitably qualified engineers should carry out maintenance.

Always check that the supply voltage specified is correct for the local AC power supply voltage.

The controller consists of electronic parts. Do not drop the controller or bump it against other objects or place the controller near heat sources such as radiators or air conditioning ducts.

Care should be taken so that solid objects or liquid do not fall into the Controller enclosure.

Clean the case with a soft dry lint free cloth, or a soft cloth lightly moistened with a mild detergent solution. Do not use any type of solvent such as alcohol, which might damage the special 'Nextel' finish.

External connections

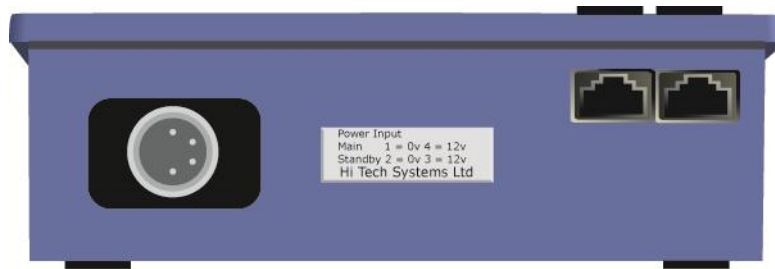

altuS rear view

Power requirements

In the UK, the mains plug should be approved to BS1363 and be fitted with a 3 amp fuse approved to BS1362.

All accessible metalwork in the room and the safety earth connections of other electrical circuits must be electrically connected together in accordance with safety regulations BS6204. This can be accomplished either by separate routes to the building earth or by bonding together or a combination of the two.

A suitable double-pole earth leakage protection device, conforming to BS6204, VDE0805 and IEC435 must be used to protect power supplied to the unit.

2 Installation

Connecting a VTR

The RS422 VTR control ports are implemented as RJ45 connectors to make the best use of space at the rear of a desk-top unit.



It is recommended not to exceed 100 metres of CAT 5 cable.

To convert RS422 ports on VTRs and other controlled devices to use RJ45 patch cables use the supplied converter at the VTRs.

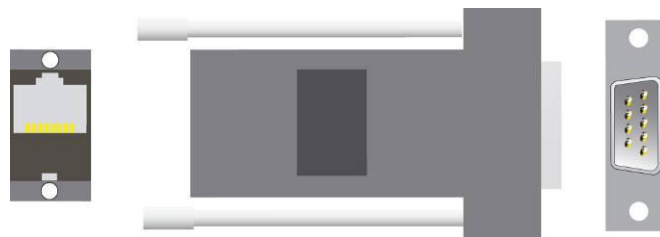

Converts VTR serial ports to RJ45

RJ45 connector pin out

Pin No	Description	RJ45 Connector
1	Chassis Gnd	<p>Chassis Connector</p> <p>Cable Connector</p> <p>View from front</p>
2	Rx A data	
3	Tx B data	
4	Tx Gnd	
5	N.C	
6	Rx Gnd	
7	Rx B data	
8	Tx A data	

CAT 5 VTR remote cables are connected to the RJ45 sockets

3 Operation



Using the main controller keys

To select a VTR for control, press the desired numbered channel selection key. The display will be updated with the timecode and transport status appropriate for the attached VTR / DDR.

The selected VTR must be enabled for remote control. If the VTR is set to operate locally from its own control panel then the controller will not function, only VTR status will be displayed.

Once the controller has control of the VTR, the REMOTE LED will illuminate. If the VTR is switched into local, or the RS422 communications becomes disconnected, the controller will sound several short warning 'bleeps' (if the bleeper has been turned ON in the menu) ,display 'Offline' and the REMOTE LED will go off.

3 Operation

How to Jog, shuttle and Var

Press the wheel to enter JOG mode. Press again to go into shuttle. Press and hold the wheel to go into variable playback mode.

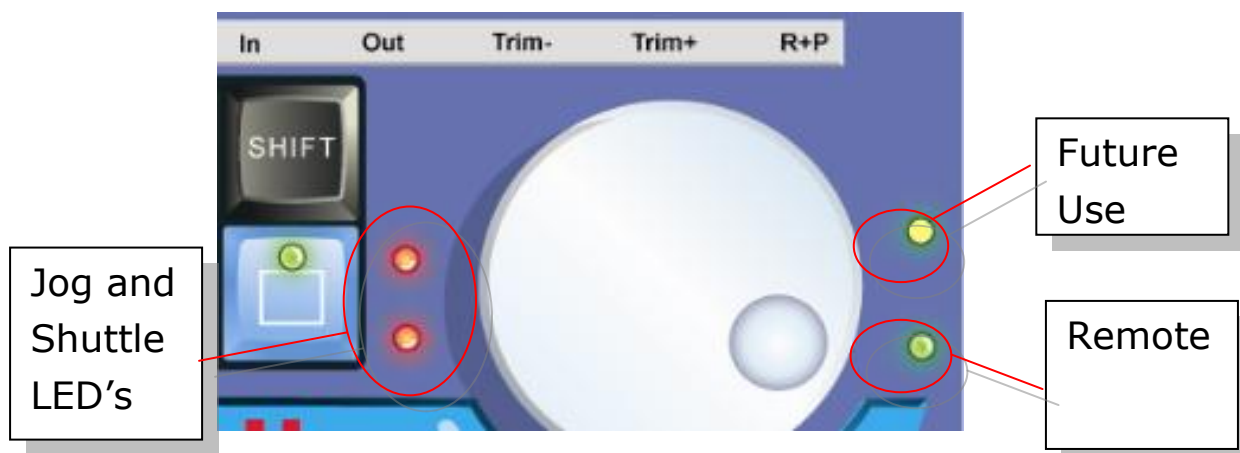

How to crash record

Menu item 7 (Record mode) should be set to "Crash". Press and hold the REC key and the PLAY key, the VTR will do an instant record.

How to stop record or playback

Press the blue stop key, this puts the VTR into STILL, press again to go into STOP mode. Press and hold the STOP key to turn "standby off".

How to select both VTR channels for group control



Grouping the channels will enable transport control over both of the connected VTR or DDR devices.

To select both VTRs for multiple controls, press both channel selection keys at the same time, this will allow transport control over both devices. To ungroup press both keys again.

Editing

The HT212e supports one and two machine editing which is selected with the **R + P** button.

If in 2 machine edit mode, then the **R + P** LED should be on and full control over the recorder and player should be possible.

If in 1 machine edit mode, then the **R + P** button LED should be off and only the Recorder (Ch2) will be able to perform an edit.

All record and playback devices must be correctly wired for video, audio, and time code.

Set the controller for either assembly editing or insert editing (see Chapter 4).

The assemble or insert lights will illuminate on the front of the VTR indicating that the VTR is set to edit.

The following 'rules' apply to all editing modes:

- IN point times must be less than OUT point times
- The controller does IN only edits by setting the OUT point time code to be the same as the IN point time code
- A suitable pre roll time should be set (normally 5 seconds)
- Trimming – The In Points and Out Points can be readjusted frame by frame by holding down the In or Out buttons and pressing Trim + or -.

3 Operation

- Comms port 1 is always regarded as the player and Comms port 2 is always regarded as the recorder
- The controller monitors both of the VTRs whilst cueing to make sure that they have reached their IN points before an edit commences
- Synchronisation between VTRs during the edit is carried out by the VTRs themselves and is locked to the reference input of the VTRs
- The VTR remains in EDIT mode until it is turned off via the menu

Edit modes also require the following switches to be set:

Set the TC on the controller to read the same time code as on the VTR, e.g. AUTO

- Set the TC generator on the record VTR for REGEN (not PRESET) and INT (not EXT)

Note: The PLAYER cannot be put into record accidentally.

Keyboard / Keypad Socket

A PS2 keypad can be connected to the controller to manually enter a desired Time code using the numerical keys and Enter. The connected device will locate the desired time code provided it is valid. Pressing the delete key will cancel time code entry.

Rules to editing with the HT212e

There are two Edit Modes available. Assemble Edit and Insert Edit.

1. **Assemble editing** - For recording the players output onto a set in point on the recorder. The Player will act as the master and the recorder will act as slave. i.e. the Player determines the end of an edit with its set **Mark Out** point.

2. **Insert Editing** - For Dubbing the required tracks (V or A) in between the recorder's set in point and out point. The Recorder will act as master and the player will act as slave. i.e. the Recorder determines the end of an edit with it's set **Mark Out** point.

Edit Mode	Player	Recorder	Edit
Assemble	With Mark In With Mark Out	With Mark In No Mark Out	Recording stops when player's Out point is reached.
Assemble	With Mark In No Mark Out	With Mark In With Mark Out	Recording will not stop.
Insert	With Mark In With Mark Out	With Mark In No Mark Out	Recording will not stop.
Insert	With Mark In No Mark Out	With Mark In With Mark Out	Recording stops when recorder's Out point is reached

3 Operation

An In-point on both the recorder and the player is always required for an edit to occur.



It is important to set the master In/Out points before the slave In point is set.

Review and Preview.

It is possible to do a 'dummy run' of the recording without actually recording. By pressing **Rec** and **Play** the controller enters 'Preview' mode.

Once an edit has been set, it is possible to Review the recording by holding down **Shift** and pressing **Play**.

Slo-Motion Recording.

It is possible to set the speed of the player for an edit by holding down the **Shift** whilst pressing down the **Jog** wheel, then release. Once in this mode, rotate the jog wheel anti-clockwise to decrease the speed from 100% to 1%. Press the jog wheel again to set it and exit.

Edit delay

Corrects the delay time from sending the RECORD command to the VTR until recording starts.

If the recording starts late increase the delay. If the recording starts early decrease the delay, (pre-set to 5 frames - see Chapter 4 to adjust). The edit delay is global for all VTRs.

Start delay

Corrects any delay in the Player VTR going into playback, (pre-set to 0 frames - see Chapter 4 to adjust).

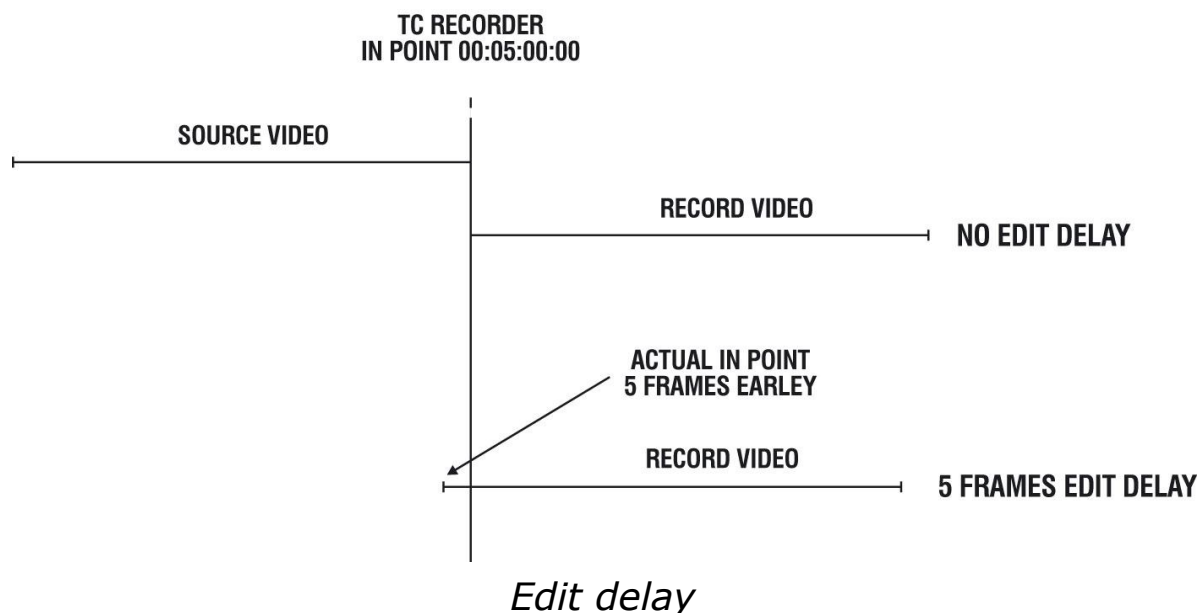

Edit Sync

Setting the Edit Sync (Yes) as default allows the HT212e to control the Player's speed during the pre-roll period. The Player will speed up or slow down to compensate for mechanical delays.

3 Operation

Advanced Operations

How to clear an in-point and out-point

There may come a time when you wish to clear a Mark In or Mark Out. This can be done in two ways.

- 1 Overwrite the existing Mark In or Out with another Mark In or Out.
- 2 Press Shift + Mark In or Shift + Mark Out to clear the existing In or Out point.

How to clear the memory, and restore to factory default?

There are times when you may want to completely erase the set timecodes of the controller and return the menu settings to there factory defaults for example after a software upgrade.

- 1 Turn off the power.
- 2 Press and hold the STOP key.
- 3 Turn the power back on.
- 4 Release the STOP key.



How to change the timecode source

You change the time code settings in the menu (see the menu section in this manual for entering the menu). The TC setting changes the time code source data (hours, minutes, seconds and frames) that is

displayed on the time code display of the controller for the connected VTRs.

The selections are: CTL, LTC, VITC and AUTO. If the display shows [--:--:--:--] then no valid time code can be read.

CTL Tape running time (hours, minutes, seconds and frames) is computed from the recorded control (CTL) signal during playback, or a count of control signal pulses during recording. These counters do not usually keep a highly accurate track of tape position.

LTC or Longitudinal time code in either 24 hour or +/- 12-hour format is usually recorded on an audio track on the tape.

LTC is read by the internal time code reader during playback or longitudinal time code reader during recording.



Time code source is selected globally for both VTRs

VITC - Vertical interval time code. This is recorded on an invisible area in the video track, and during playback read by the internal time code reader or vertical interval time code reader during recording.

AUTO Time code is selected automatically by the VTR depending on the speed of the tape. Typically VITC is selected when the tape transport speed is up to half speed, and LTC when it is more than half speed.

3 Operation

Setting TCG and CTL



To set TCG the VTR must be set to TC generator pre-set mode.

Specific times for the VTR timecode generator and CTL counter may be set from within the menu.

It is also possible to recall the last time code or control track time set. For example to store and recall 09:58:00:00,

enter the menu select TCG and use the wheel to change the time to 09:58:00:00

How to enter and exit the altuS SETUP menu.

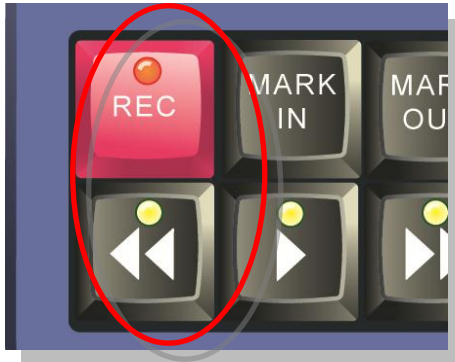

There are times when you may want to change certain altuS operational parameters. This is accomplished via its SETUP menu. It is here where you will be offered setup parameters to choose from. To enter and exit SETUP:

Press and hold the REC key and the REW key.

How to change operational parameters in the SETUP menu

Turn the WHEEL to “point” the display chevron to the line item you wish to change, a chevron > indicates the active display line.



Press and hold down the STOP key to change the setting of the selected parameter.

Change the parameter by turning the WHEEL.

Menu Operational settings

1. Eject

YES or NO

NO ^{DEF}

Description: Ejects tape from VTR.

When tape is ejected the MENU mode is exited, the bleeper will sound and a 'Cassette out' message will be displayed.

2. TC Mode

Cue controller only

CTL, LTC, VITC, AUTO

AUTO ^{DEF}

Description: Set the timecode standard.

3. Set CTL

hh:mm:ss:ff

Description: Allows the tape timer numbers inside the VTR to be set. Some VTRs will not allow the tape timer to be set, so this item may have no effect. To move between hh:mm:ss:ff turn the wheel. Press and hold down the || key, and turn the wheel to alter the numbers.

To recall the last setting stored, enter the menu mode and select CTL, press the TC button to load the new CTL and exit the menu mode.

4. Set CTL mode

12Hr / 24Hr

24 ^{DEF}

Description: Changes the CTL display to display timecode in +/-12 hours mode or 24 hours mode.

5. Set TCG

hh:mm:ss:ff 00:00:00:00 ^{DEF}

Description: Allows VTR T/C generator numbers to be preset. Useful to force an edit or hard record to start with tape time code at a particular number. To move between hh:mm:ss:ff turn the wheel. Some VTRs do not support this command. Press and hold down the || key, and turn the wheel to alter numbers. To recall the last setting stored, enter the menu mode select TCG. Press the T/C button to load the new TCG and exit the menu mode.

6. Preroll

nn secs 0 secs ^{DEF}

Description: Offset the MARK IN time. The timecode stored will be the time at the point the MARK IN key was pressed less the mark preroll time

7. Record Mode

Crash, Assemble, Insert. **Assemble** ^{DEF}

Description: Affects the recording mode when RECORD and PLAY keys are simultaneously pressed.

Crash This is the fastest way to put a VTR into record. All video, audio tracks, linear timecode and control track are recorded and no attempt is made to join to any previous material.

Since crash-recording mode destroys any CTL information that might already be on the tape at the start and end of the recording, the playback just at the start and end of the recording will have picture disturbance.

Crash record is usually used to make the first recording on a blank tape.

3 Operation

Assemble Starts to record in assemble edit mode. New video, audio tracks, linear timecode and control track are recorded and joined to any previous material.

Since, assemble recording mode destroys any CTL information that might already be on the tape at the end of the recording, playback at the end of the recording will have picture disturbance.

Insert Starts to record in the Insert edit mode. Insert allows you to define which video and audio tracks are selected using the jog/shuttle key and the wheel. Existing control track and linear timecode are preserved and playback discontinuities at the start and end of the recording are minimised.

The tracks are displayed as follows:

V 1 2 T 4 1 2 3 4 5 6 7 8

* * * * * * * * * * * *

The * indicates that the track is enabled. The first 4 tracks labelled 1,2,T and 4 are audio analogue tracks and the second set of tracks 1 - 8 are digital audio tracks.

The Record start and end points are made with clean edit points, therefore enabling replay at the start and end of the recording.

8. Video & Audio track selection.

9. Fast Cue

NO or Yes

No ^{DEF}

Description: Some VTRs cue tape very slowly using the standard cue command. Fast cue mode allows fast forward and rewind commands in CUE mode. These commands are used for cueing until the tape position is within a few seconds of the cue point, then the cue command is issued.

10. Rec Inhibit Play

No, Yes

Yes ^{DEF}

Description: Inhibits the player to be recorded to.

11. Lock VTR

Cue controller only

NO or YES

NO ^{DEF}

Description: Locks the PLAY and RECORD transport controls only. Note: the controller must be in PLAY or RECORD first before turning this mode on. Enter menu again to turn OFF lock.

12. Edit Delay

nn frms

0 frames ^{DEF}

Description: 1. Corrects the delay time from sending the RECORD command to the VTR until recording starts.
2. Sets the amount of time the VTR will cue back after an auto cue.

3 Operation

13. Play Start Delay

nn frms 0 frames ^{DEF}

Description: Corrects the delay from sending the PLAY command to the player VTR.

14. Jog Rate,

15. Var Rate,

16. Shuttle Rate

Min, Slow, Norm, Fast, Max Normal ^{DEF}

Description: Changes the reaction time of the wheel input to the tape being replayed to compensate for tape, disk and operator preference. For example if the Jog speed is set to Min, then more than one complete turn of the wheel is required to advance a frame.

Setting	Jog reaction time	Shuttle range	Var range
Min	Minimum	+/- 1.0	+/- 0.25
Slow	Slow	+/- 2.0	+/- 0.33
Norm	Norm ^{DEF}	+/- 15 ^{DEF}	+/- 0.5
Fast	Fast	+/- 24	+/- 1.0 ^{DEF}
Max	Maximum	+/- 50	+/- 2.0

17. Clear Config

NO, YES NO ^{DEF}

Description: Restores the factory default conditions. See all items marked as ^{DEF}.

18. Beeper

Off, On, Error Off ^{DEF}

Description: Turn the beeper function on/off.

19. Vid Std

PAL, NTSC

PAL ^{DEF}

Description: Sets the T/C to run on either PAL or NTSC standard

20. EE mode auto or full

AUTO ON, AUTO OFF, FULL ON, FULL OFF

AUTO ON ^{DEF}

Description: Change the EE function from automatic to manual.

21. Edit Sync

Yes, No

Yes ^{DEF}

Description: Determines whether the player should speed up or slow down to account for VTR mechanical delay and to allow the edit to be frame accurate.

4 Trouble Shooting

The following section lists commonly asked questions and their solution:

Why do labels appear as | | | | when powering the controller for the first time?

This indicates the default settings of the controller need to be stored in the non-volatile memory (see Chapter 4 – Engineering menu - Clear Config).

The controller has emitted several short 'beeps' and the remote LED has gone off. What's the problem?

Check that the VTR is not switched into local or that the RS422 communications link is not disconnected.

How do you change settings in the Menu?

The key MUST be held down to allow the wheel to change assigned parameter values on the bottom display line.

Where is the tape eject button?

This is the first command available from the Menu.

There is no communications to or from the VTR?

Check that the cable adaptors have been made correctly.

Addendum

Summary of functions

Function	Keys	Description
Play	[▶]	The VTR will play
Still / Stop	[■]	First press the VTR will be in still mode, second press the VTR will be in stop mode.
Standby Off	[■] for > 1 second	The VTR will "spool down" – head drum will stop and tape unthread
Edit	[REC]	Performs the pre-set edit.
Preview	[REC]+ [▶]	Previews the pre-set edit without recording.
Jog	○ ● press wheel	Puts the selected VTR into Jog mode.
Shuttle	○ ● press wheel	Puts the selected VTR into shuttle mode
Vari Speed	● ● press and hold the wheel	Puts the selected VTR into variable mode the range depends on the menu setting
Review	[SHIFT] + [▶]	Reviews the pre-set Edit.
Timecode mode	Menu setting	The timecode can be set to LTC, CTL, VITC and AUTO
Make a Mark In point	[MARK IN]	Creates a Cue in point.

Addendum

Function	Keys	Description
Make a Mark Out point	[MARK OUT]	Creates a Cue out point. Cue No. displayed briefly, when button pressed
Clear Mark In or Mark Out	[SHIFT] + [MARK IN] or [MARK OUT]	Clears the stored Mark In or Mark Out for the selected device.
Select the Recorder or Player.	[1] or [2]	Selects the Player (port 1) or Recorder (Port 2).
Group Channels	[1]+[2]	Hold down the 2 Channel buttons to enter Group mode.
Recorder and Player. Only Effective in Group Mode.	[R+P]	Enables 1 or 2 machine edit mode. If ON, then the controller is in 2 machine edit mode.
Display in-point	Hold [In]	Shows the current Mark In point of the selected device.
Display out-point	Hold [Out]	Shows the current Mark Out point of the selected device.
Show Duration	Hold [In] + [Out]	Displays the duration of the edit.
Go to In-point	[SHIFT] + [In]	Go to current In point.
Go to Out-Point	[SHIFT] + [Out]	Go to current Out point.
Trim Decrement	Hold [In] or [Out] and press [Trim-]	Decreases the current in or out point of the selected device.
Trim Increment	Hold [In] or [Out] and press [Trim+]	Increases the current in or out point of the

selected device.

Speed Offset	Hold [SHIFT] + ●● press wheel. Turn wheel to adjust.	Enables the controller to change the speed of Playback of the connected player. Used for SloMotion recording. Turn the wheel to set the required speed then release the Shift button.
Eject the tape	[MENU]	Eject must be selected from the menu using the jog wheel

Outline dimensions

The altuS has the following outline dimensions:

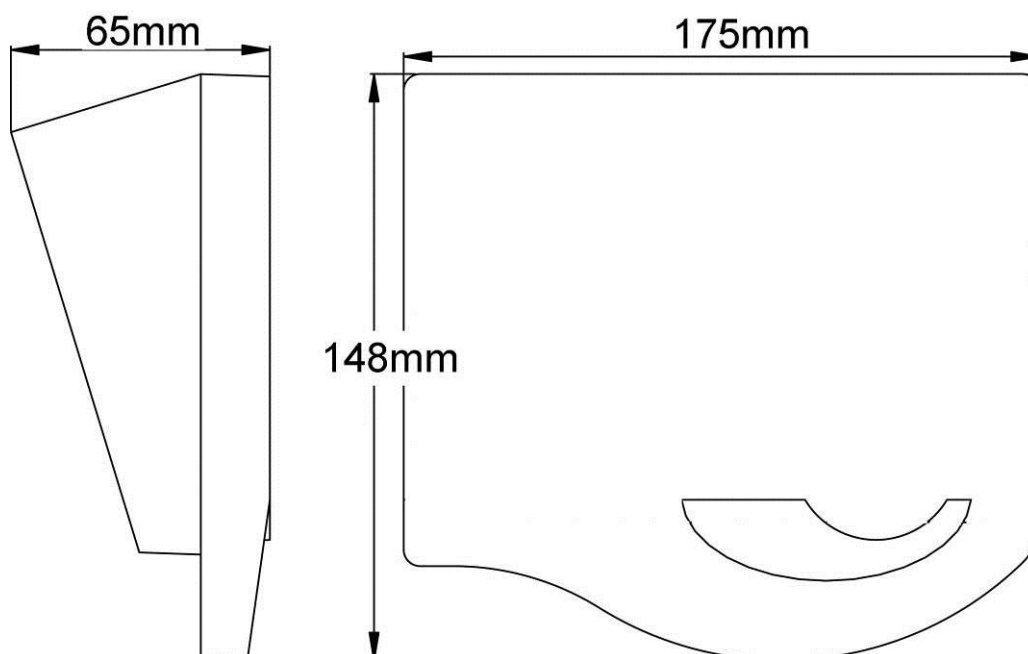

Software Updates

Addendum

Download the software update wizard actiV8 from the Hi Tech Systems support web site at:

http://www.hitechsys.co.uk/html/support/support_overview.html

and contact Hi Tech Systems for the latest software version.

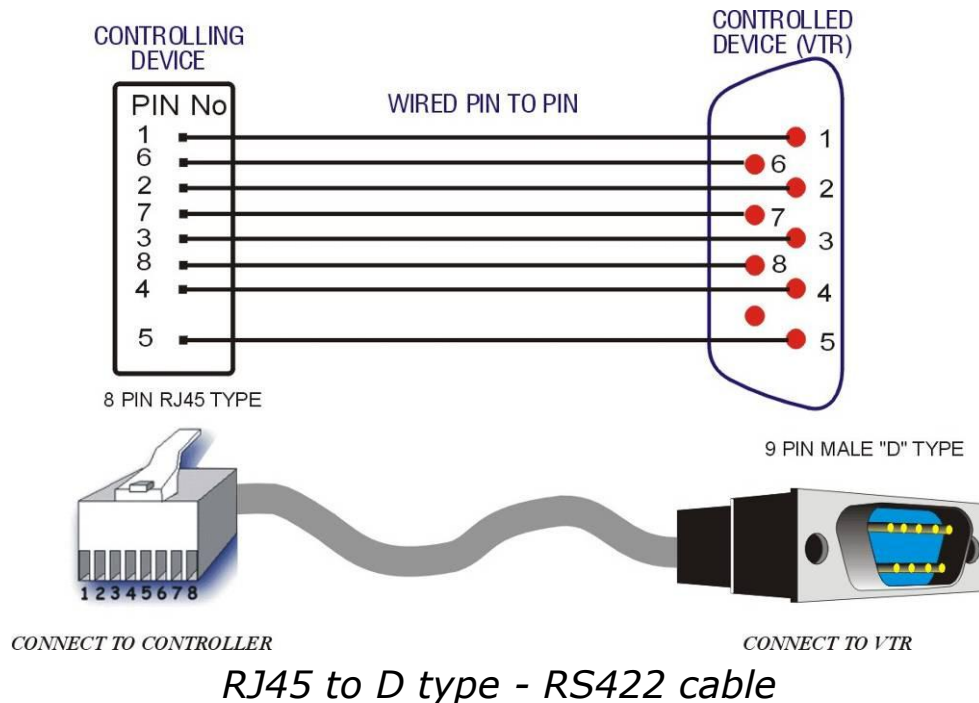

Cable pin out reference

The following diagrams are provided for those wishing to make their own cables.

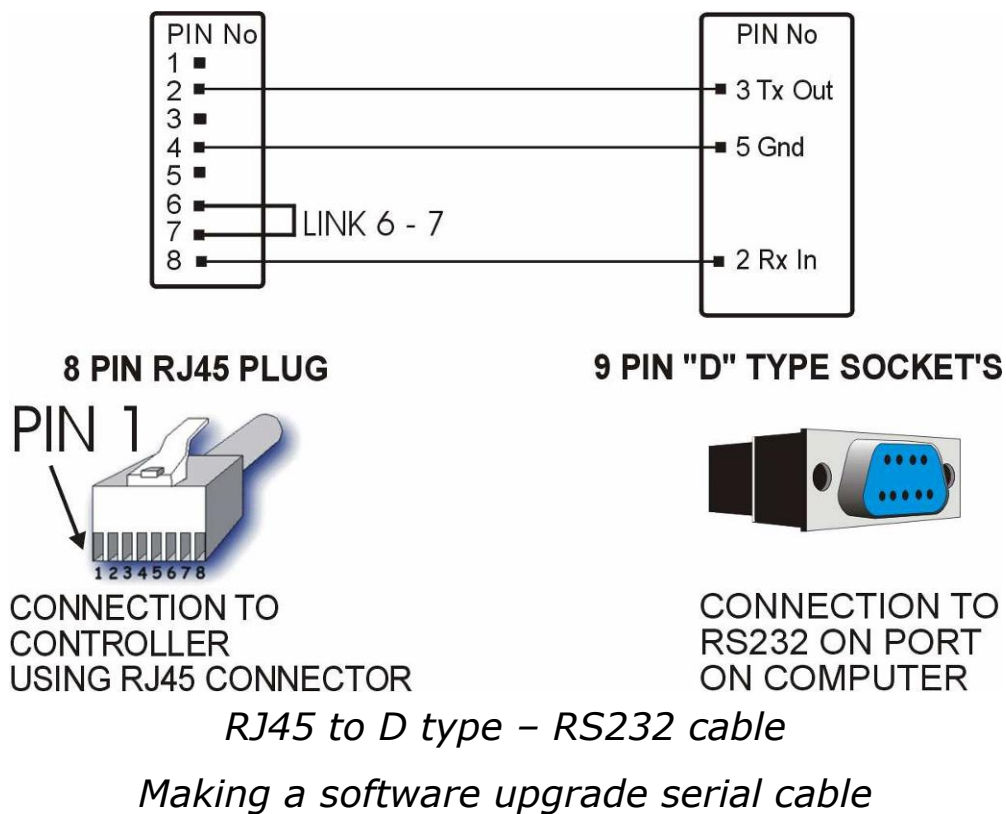
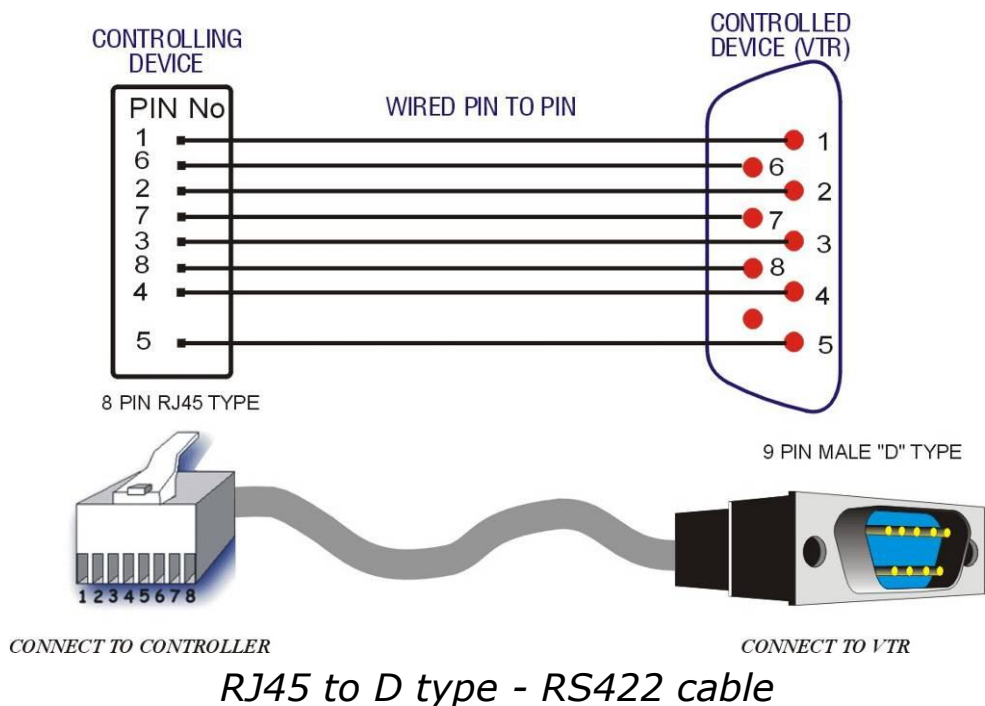

Notes on PC serial connectors

Some computers, particularly laptops have odd earth arrangements on the RS232 connector, making the download problematic. If possible, use a desktop PC for performing s/w updates.

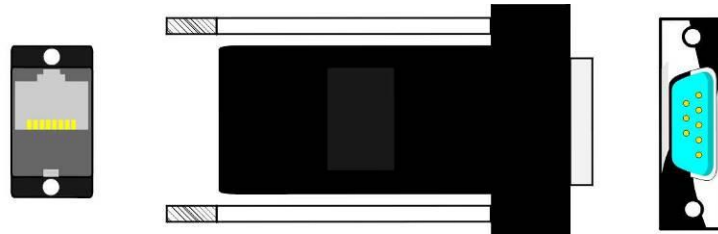

PIN	Description	Colour (shielded)	Colour (un-shielded)
1	Chassis Gnd	BLUE	BLACK
2	Rx A data	ORANGE	YELLOW
3	Tx B data	BLACK	ORANGE
4	Tx Gnd	RED	RED
5	N.C	GREEN	GREEN
6	Rx Gnd	YELLOW	BROWN
7	Rx B data	BROWN	GREY
8	Tx A data	WHITE	BLUE



*Making the RJ45 to RS422 **male** adapters*

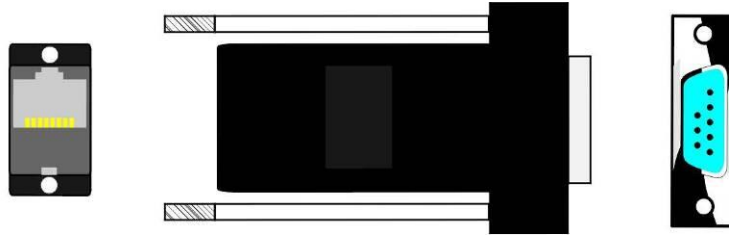

PIN	Description	Colour (shielded)	Colour (un-shielded)
1	Chassis Gnd	BLUE	BLACK
2	Rx A data	ORANGE	YELLOW
3	Tx B data	BLACK	ORANGE
4	Tx Gnd	RED	RED
5	N.C	GREEN	GREEN
6	Rx Gnd	YELLOW	BROWN
7	Rx B data	BROWN	GREY
8	Tx A data	WHITE	BLUE

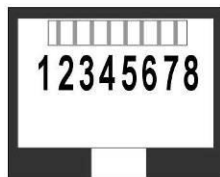

VIEW FROM THE OUTSIDE

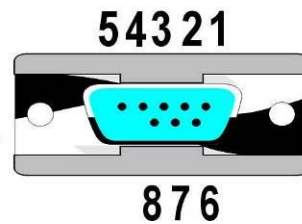

Making the RJ45 to RS422 **female** adapters

6 Specification

Control ports

Communication Format: RS-422-A

Communication Channel: Full Duplex

Data Signalling Rate: 38.4 Kb/s (K bits per second)

Communication Protocol: SONY 9 pin RS422

Serial connectors: 2 x RJ45 – 8 pin sockets

VTRs controlled: VTRs that support the Sony RS422 9 pin protocol

Power

Mains input: 110 – 240V AC IEC to Female XLR DC Mains Adaptor

Voltage: 12V DC

Power consumption: Less than 5 watts

General

Operating Temp: 0 - 35 Deg C