

# **TANNOY®**

## **iQ SERIES USER MANUAL**

**iQ 10, iQ 10P, iQ 10C AND  
iQ 10PC MODELS**



## **CONTENTS**

- 1. Introduction**
- 2. Unpacking**
- 3. Connectors/Cabling**
- 4. Amplification & Power Handling**
- 5. Operation**
- 6. Equalisation**
- 7. Arraying**
- 8. Dimensions**
- 9. Rigging & Suspension**
  - General Safety Advice
  - Skeletal Flying
  - SECUR – ET VPC Pole Clamp
  - SECUR ET – VEB Eyebolt
  - Suspension Truss
- 10. Performance Data**
- 11. Technical Specifications**
- 12. System Configuration & OEM Controllers**
  - Bi-amp System Parameters (iQ 10 & iQ 10C)
  - Passive System Parameters (iQ 10P & iQ 10PC)
- 13. Recommended Service Parts & Accessories**
- 14. Warranty**
- 15. Declaration of Conformity**

## 1. Introduction

Thank You for purchasing Tannoy PowerDual™ iQ 10.

The iQ 10 has been designed for live and fixed installation music and speech sound reinforcement applications. They are specifically designed for use in venues, theatres, arenas and distributed systems in stadiums. The iQ 10 can be used both indoors and out due to its durable “skeletonised” plastic weatherproof enclosure.

The iQ 10 utilises a point source 10” PowerDual™ driver utilising the unique Funktion One Research engineered and patented Axhead™ technology, which provides a controlled 60° × 40° (H × V) dispersion, covering a frequency range from 180Hz to 18kHz. For low frequencies, the iQ 10 has been designed to operate in conjunction with the iQ 18B sub-woofer, where overall system balance is achieved by using the TDX1 or TDX2 system controller, with provision for the relevant cross-over frequencies, delays, gains, high and low pass filters and parametric EQ amongst other features.

Tannoy’s, iQ 10 is a weatherproof skeletal design suitable for use both indoors and out, where the compact and lightweight unit allows for flying into tight corners. The iQ 10 has two Speakon™ connectors for ease of installation. An optional plywood cabinet is also available to match the iQ 18B profile where they can be flown together using additional hardware for flying.

The iQ10 comes in 4 variants:-

- iQ 10 - Skeletal iQ 10 Configured for Bi amp operation.
- iQ 10P - Skeletal iQ 10 with internal passive crossover.
- iQ 10C - iQ 10 Configured for Bi amp operation in plywood cabinet.
- iQ 10PC - iQ 10 with internal passive crossover in plywood cabinet.

## 2. Unpacking

Every Tannoy iQ10 is carefully tested and inspected before packing. After unpacking, please inspect your iQ10 for any damage sustained during transit. In the unlikely event of any damage, would you please notify your dealer immediately and retain your shipping carton, as your dealer may ask the faulty unit to be returned for inspection.

## 3. Connectors/Cabling

The iQ 10 is fitted with two 4-pole Speakon™ connectors. Speakon™ has the following advantages over EP and XLR type connectors: All terminations are solderless, making life easier at the time of installation or when field servicing is required. Contacts will accept 6 sq. mm wire with an outside diameter of up to 15 mm and a current rating of 30 Amps.

The pins of the Speakon™ sockets, marked input/output on the rear of the speaker, are paralleled within the enclosure.

Tannoy has adopted the following wiring standard for iQ 10: -

Mode Of Operation		
Speakon Pin No.	Passive (iQ 10P, iQ 10PC)	Bi – Amp (iQ 10, iQ 10C)
1+	Full Range +	LF +
1-	Full Range -	LF -
2+	No Connectors	HF +
2-	No Connectors	HF -

For a worldwide list of Neutrik distributors see <http://www.neutrik.com/>

Cable choice consists mainly of selecting the correct cross sectional area in relation to the cable length and the load impedance. A small cross sectional area would increase the cables series resistance, inducing power loss and response variations (damping factor).

Connectors should be wired with a minimum of 2.5 sq. mm (12 gauge) cable. This will be perfectly satisfactory under normal conditions. In the case of very long cable runs the wire size should exceed this, refer to the following table for guidance: -

CABLE RUN (m)	C.S.A. OF EACH CONDUCTOR (mm)	CABLE RESISTANCE $\Omega$	% POWER LOSS INTO 8 $\Omega$ LOAD	% POWER LOSS INTO 4 $\Omega$ LOAD
10	2.5	0.14	1.7	3.5
	4.0	0.09	1.1	2.2
	6.0	0.06	0.73	1.5
25	2.5	0.35	4.3	8.6
	4.0	0.22	2.7	5.4
	6.0	0.14	1.8	3.6
50	2.5	0.69	8.6	17.0
	4.0	0.43	5.4	11.0
	6.0	0.29	3.6	7.2
100	2.5	1.38	17.0	35.0
	4.0	0.86	11.0	22.0
	6.0	0.58	7.2	14.0

#### 4. Amplification & Power Handling

As with all professional loudspeaker systems, the power handling is a function of voice coil thermal capacity. Care should be taken to avoid running the amplifier into clip (clipping is the end result of overdriving any amplifier). Damage to the loudspeaker will be sustained if the amplifier is driven into clip for any extended period of time. Headroom of at least 3dB should be allowed. When evaluating an amplifier, it is important to take into account its behaviour under low impedance load conditions. A loudspeaker system is highly reactive and with transient signals it can require more current than the nominal impedance would indicate.

Generally, a higher power amplifier running free of distortion will do less damage to the loudspeaker than a lower power amplifier continually clipping. It is also worth remembering that a high powered amplifier running at less than 90% of output power generally sounds a lot better than a lower power amplifier running at 100%. An amplifier with insufficient drive capability will not allow the full performance of the loudspeaker to be realised.

It is important when using different manufacturers amplifiers in a single installation that they have very closely matched gains, the variation should be less than +/- 0.5dB. This precaution is important to the overall system balance when only a single compressor/limiter or active crossover is being used with multiple cabinets; it is therefore recommended that the same amplifiers be used throughout.

#### 5. Operation

For optimal performance, the iQ 10 has been designed to operate in conjunction with the Tannoy TDX1 & TDX2 System Controllers, and iQ 18B bass unit for extended bass performance. The TDX controllers have been factory preset to provide the recommended eq, crossover points, and overall system balance. Please refer to the TDX1 & TDX2 manual for operation.

If you intend using an alternative loudspeaker management system (e.g. BSS™, KlarkTeknik™, XTA™ etc) please refer to section 12 of this manual.

## 6. Equalisation

Over equalisation can reduce system headroom, and introduce phase distortion resulting in greater problems than cures. If equalisation is required then it should be applied gently and smoothly. Violent equalisation will be detrimental to the overall sound quality.

## 7. Arraying

Comb filtering is a phenomenon, which cannot be cured by equalisation. Small alterations to loudspeaker positions can have the effect of minimising problematic combing frequencies. Arrays should be constructed so that the individual coverage patterns of each loudspeaker combine with minimal overlap. The design of the iQ 10C cabinet greatly simplifies the creation of effective arrays, allowing seamless wide (120 degree) horizontal coverage using two loudspeakers without the need for tedious experimentation.

By placing the iQ 10C cabinets as shown in the diagram below, minimal dispersion pattern overlap is achieved, guaranteeing an extraordinarily smooth transition.

It is also possible to stack the cabinets vertically using the above method, say for use in a central cluster, where greater vertical dispersion is required.

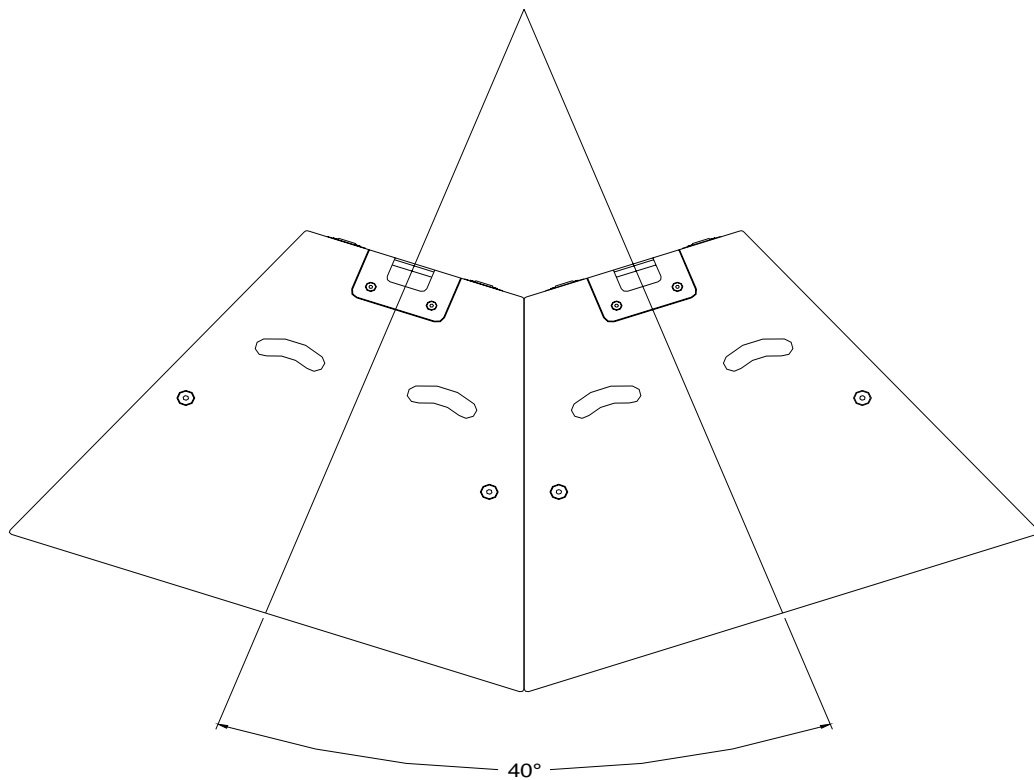

## 8. Dimensions

### IQ 10 & iQ 10P

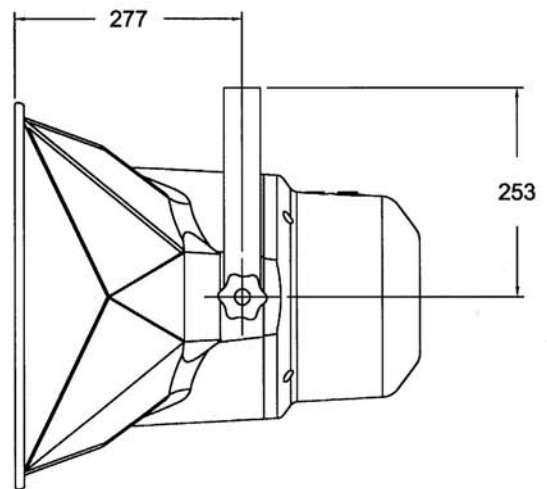
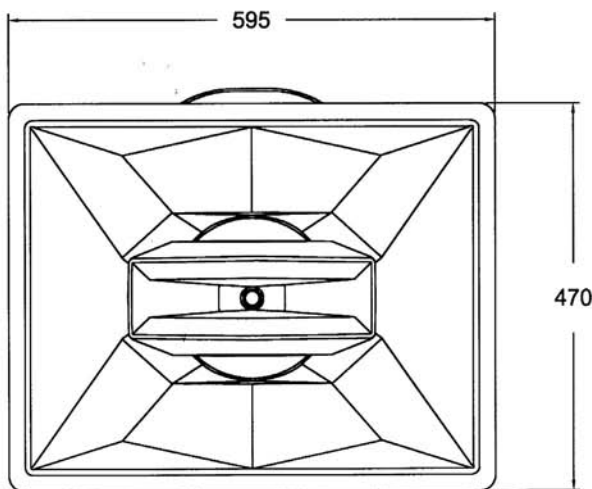
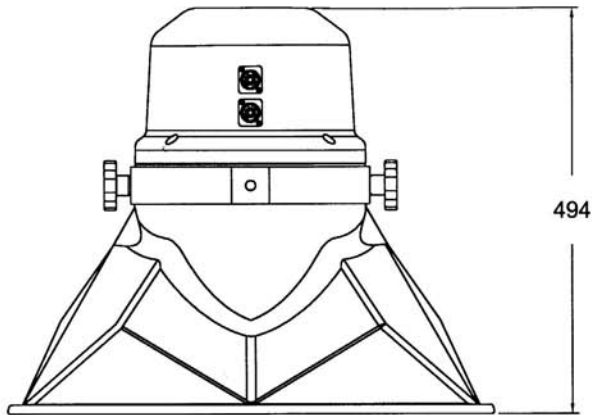

# iQ 10C & iQ 10PC

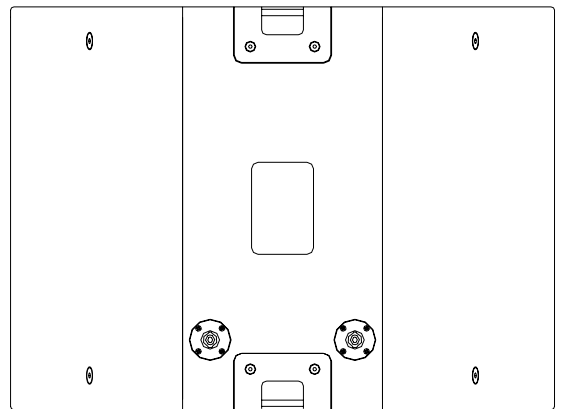
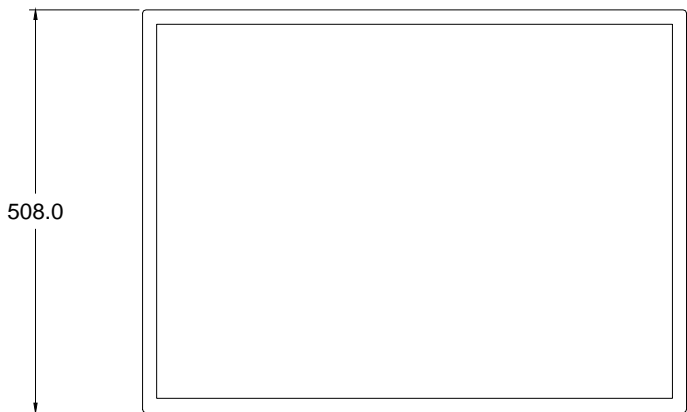
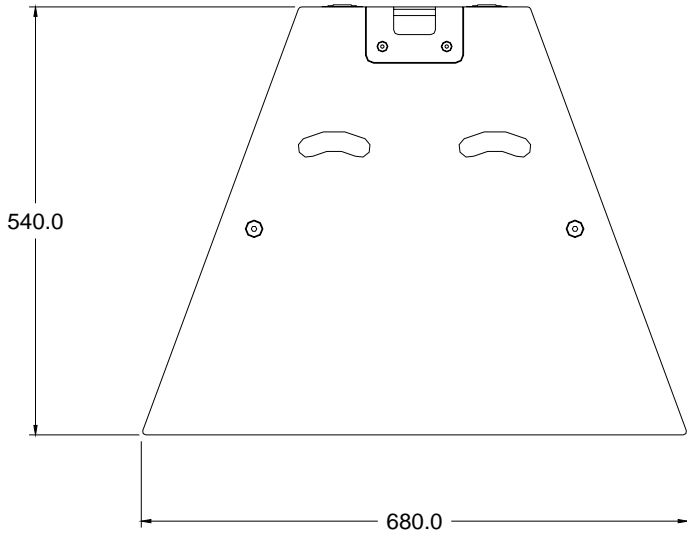



## 9. Rigging & Suspension

### General Safety Advice



The Tannoy Professional hardware covered in this guide has been designed to offer quick, simple, cost effective and secure solutions for mounting specific Tannoy Professional loudspeakers. This hardware has been designed and manufactured with a high safety load factor for its specific role. To ensure the safest possible use of the hardware covered in this guide, it must be assembled in strict accordance with the instructions specified. The information relating to the assembly and the safe use of these accessories must be understood and followed. The installation of Tannoy Professional loudspeakers using the dedicated hardware should only ever be carried out by fully qualified installers, in accordance with all the required safety codes and standards that are applied at the place of installation.

**WARNING:** As the legal requirements for flying change from country to country, please consult you local safety standards office before installing any product. We also recommend that you thoroughly check any laws and bylaws prior to commencing work.

Tannoy Professional hardware has been designed for use with specific Tannoy Professional loudspeakers, and is not designed or intended for use with any other Tannoy Professional products, or any other devices. Using Tannoy Professional hardware for any purpose other than that indicated in this guide is considered to be improper use. Such use can be very dangerous as overloading, modifying, assembling in anyway other than that clearly stated in the manual, or damaging Tannoy Professional hardware will compromise safety.

The component parts of any Tannoy Professional hardware device must only be assembled using the accessory kits supplied and in strict compliance with the user manual. The use of other accessories or non-approved methods of assembly may result in an unsafe hardware system by reducing the load safety factor. Welding, or any other method of permanently fixing hardware components together or to the integral fixing points in the cabinet should never be used.

Whenever a Tannoy Professional loudspeaker is fixed to a surface using a Tannoy Professional hardware device, the installer must ensure that the surface is capable of safely and securely supporting the load. The hardware employed must be safely, securely, and in accordance with the manual, attached both to the loudspeaker and also to the surface in question, using only the fixing holes provided as standard and covered in the manual. Secure fixings to the building structure are vital. Seek help from architects, structural engineers or other specialists if in any doubt.

All loudspeakers flown in theatres, nightclubs, conference centre or other places of work and entertainment must, be provided with an independent, correctly rated and securely attached secondary safety – in addition to the principle hardware device. This secondary safety must prevent the loudspeaker from dropping more than 150mm (6") should the principle hardware device fail.

The iQ 10 & iQ 10P is supplied as a 'skeletal' design loudspeaker, which can be used both indoors and out due to its weatherproof exterior. As it is compact and lightweight, it can easily be flown into tight corners and small spaces. The iQ 10C & iQ 10PC are built into plywood cabinets that match the profile of the iQ 18B sub bass cabinet. If the iQ 10 is flown outdoors, please note the unit should be positioned such that the Speakon™ connectors are facing downwards, to avoid excess moisture leaking into the socket.

The following optional flying kit is available:

### **Skeletal Flying**

The iQ 10 'skeletal' enclosure include a yoke as standard. The unit can be flown from a flying bar or relevant rigging via the flying loop, by utilising a Tannoy SECUR-ET VPC hook clamp or equivalent.

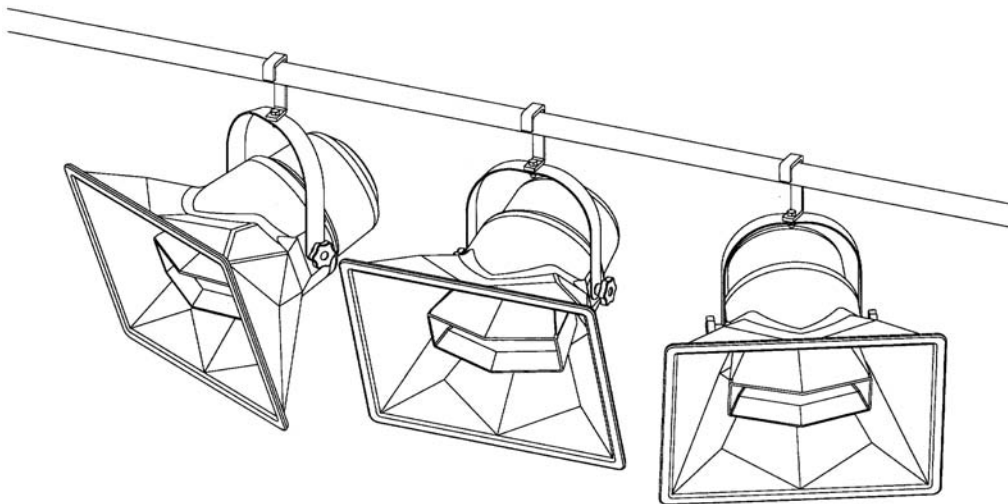

## SECUR – ET VPC Pole Clamp

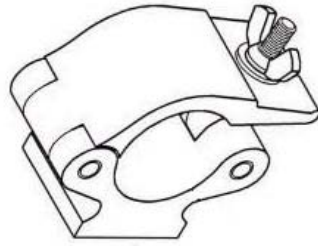

The VPC pole clamp can be used along with the iQ10 yoke bracket to suspend the loudspeaker from an overhead bar, truss or suitable structure. Only the parts supplied should be used to secure the VPC to the yoke bracket.

The following items are included with each VPC:-

Description	Quantity
VPC Pole Clamp	1
M10 Washer	1
M10 x 50mm Screw	1
M10 Nyloc Nut (Black)	1

## SECUR ET – VEB Eyebolt

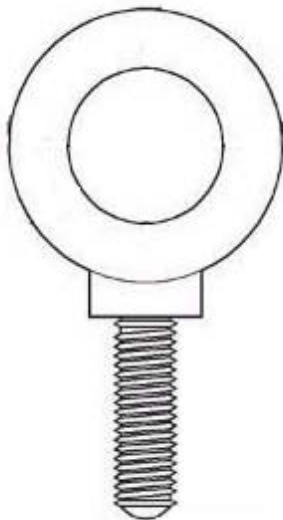

The Tannoy iQ 10C & iQ 10PC loudspeakers can be flown with high quality VEB M10 eyebolts with collar to BS4278:1984. The loudspeakers are equipped with internal steel braces, which also double as the flying points, and accept VEB M10 eyebolts.

To install the VEB M10 eyebolts remove the original M10 counter sunk screws from the locations you wish to install the VEB M10 eyebolts. Then replace these counter sunk M10 screws with the VEB M10 eyebolts. The kelping brackets on the rear of the cabinet should **only** be used for tilting the loudspeaker to the desired angle.



**Important: It is imperative for safety reasons that two eyebolts linked to two independently fixed straps are used per cabinet. Never attempt to use formed eyebolts i.e. formed from a steel rod and bent into an eye.**

## **SINGLE IQ SUSPENSION TRUSS (By ATM™)**

The iQ suspension truss is an economical solution to suspending a single purpose loudspeaker array from two or three fixed structural attachment points. The iQ Suspension Truss is designed to hold the loudspeakers at the optimum splay angle to optimize cluster performance. Most Suspension Trusses are equipped with two suspension rails with multiple attachment holes that travel from front to back across the top of the array, allowing manipulation of the center of gravity of the cluster to achieve down tilt without a pull strap.

Features:

- Optimized fixed splay angle
- Adjustable tilt
- Fast multiple enclosure rigging system
- Economical
- Low profile, clean looking array

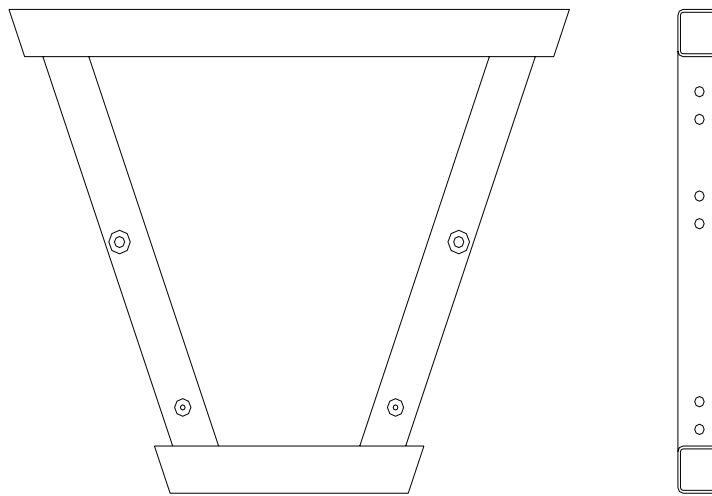

**iQ Suspension Truss**

The iQ Suspension Truss is a "semi-custom" product line that is built to order. Please contact your Tannoy or ATM Fly-Ware dealer with the loudspeaker model numbers along with the array application.

Full assembly instructions for the iQ Suspension Truss accompany the product.

## Typical Suspension Truss applications –

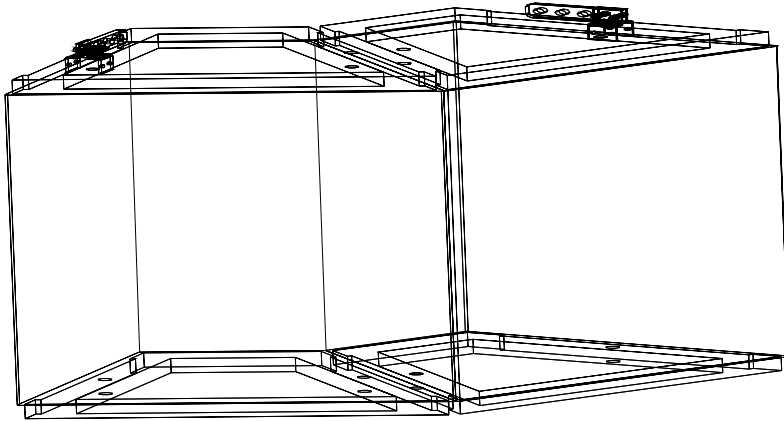

**2 x iQ 10C**

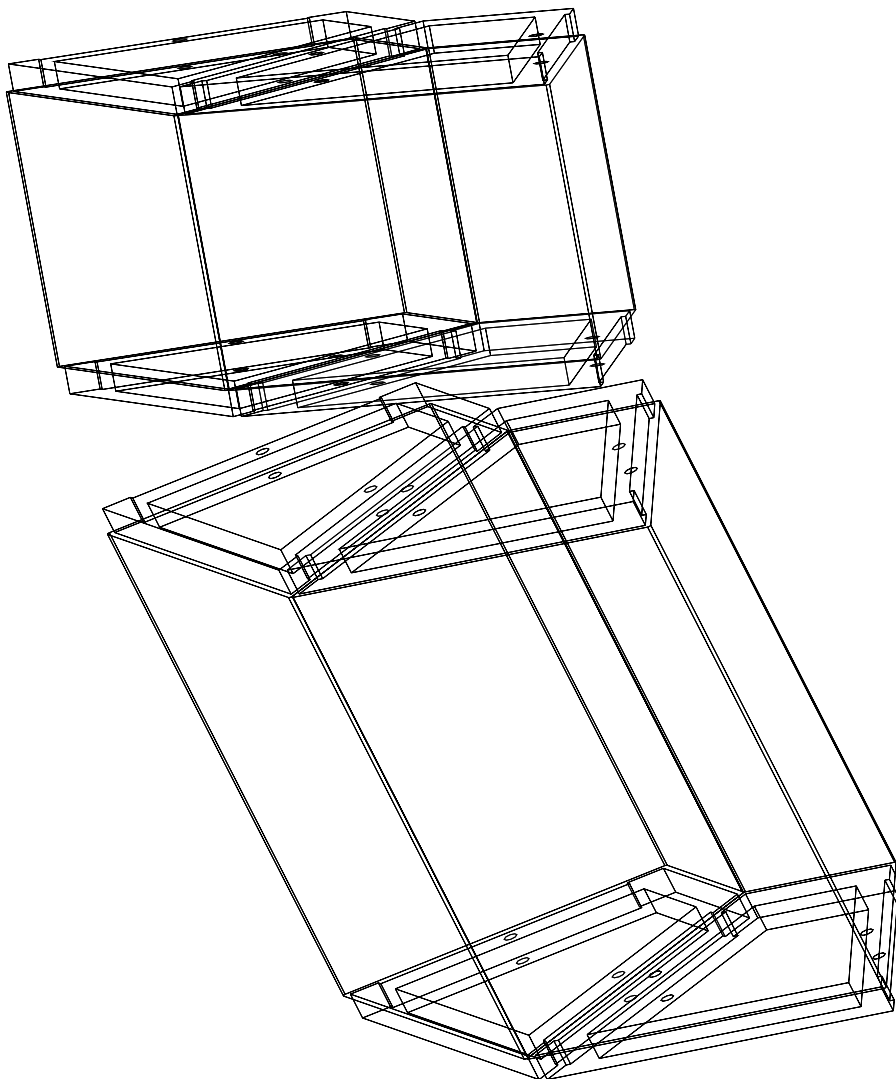

**2 x iQ 10C & 2 x iQ 18B**

## 10. Performance Data

### FREQUENCY RESPONSE (iQ 10)

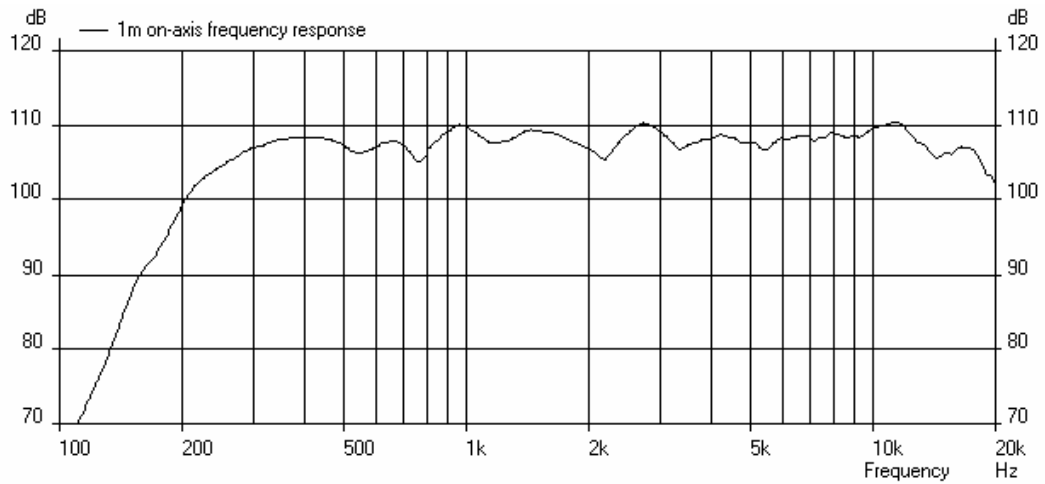

System Frequency Response (with system controller) @ 1m on axis



### FREQUENCY RESPONSE – Midrange (iQ 10)

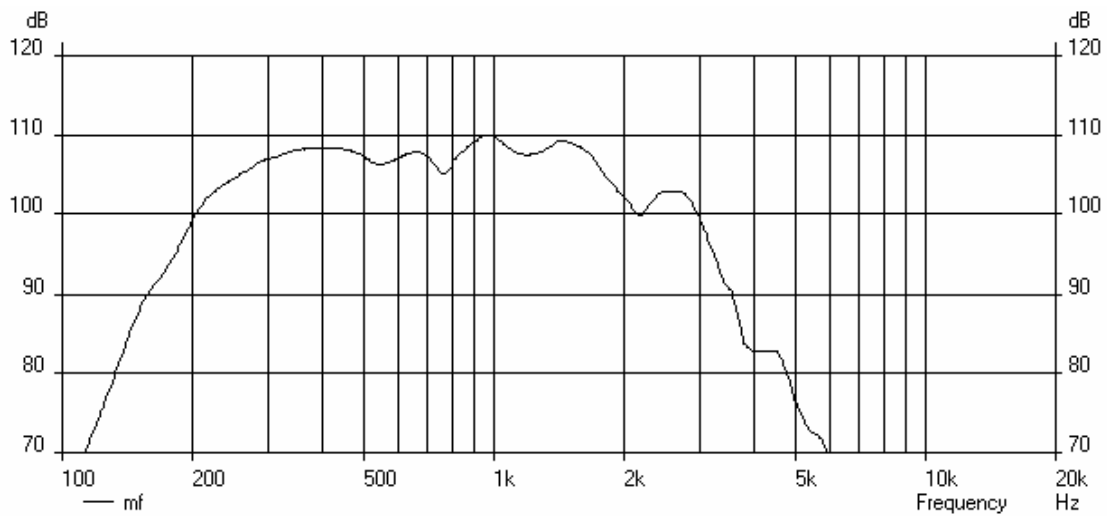

## FREQUENCY RESPONSE – High Frequency (iQ 10)

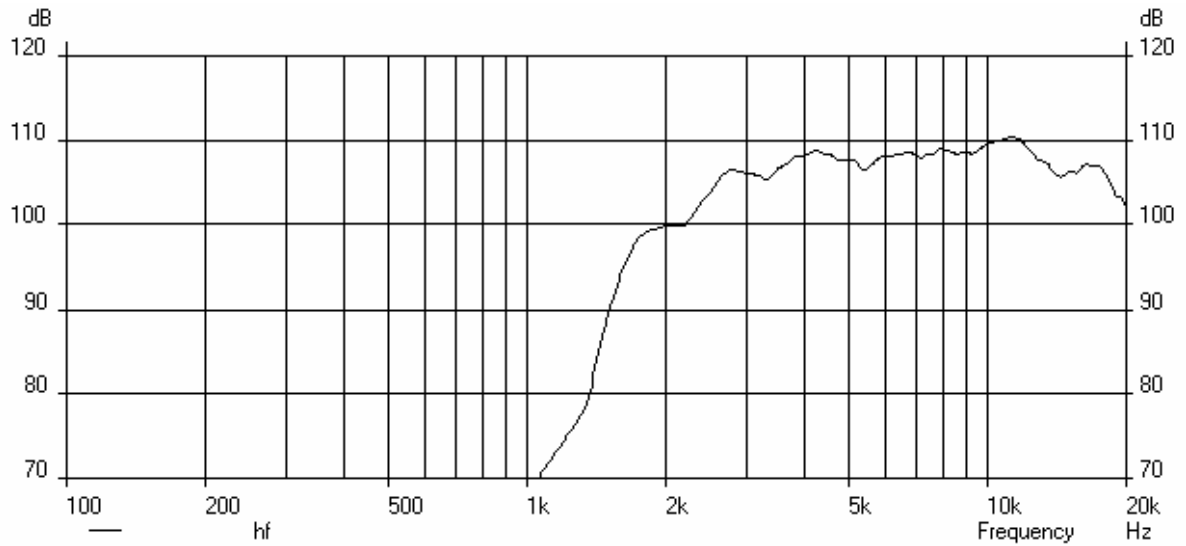

## INPUT IMPEDANCE – Midrange (iQ 10)

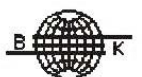
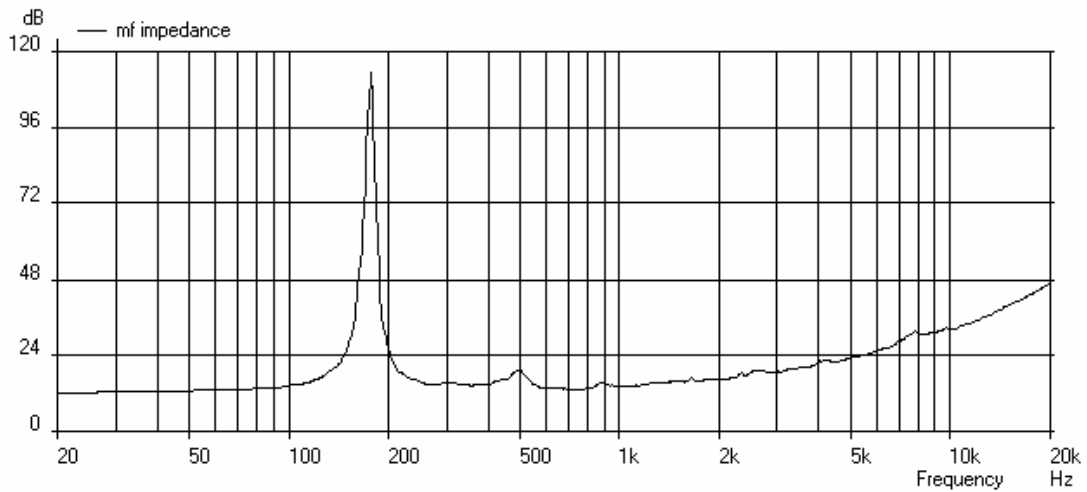

## INPUT IMPEDANCE – High Frequency (iQ 10)

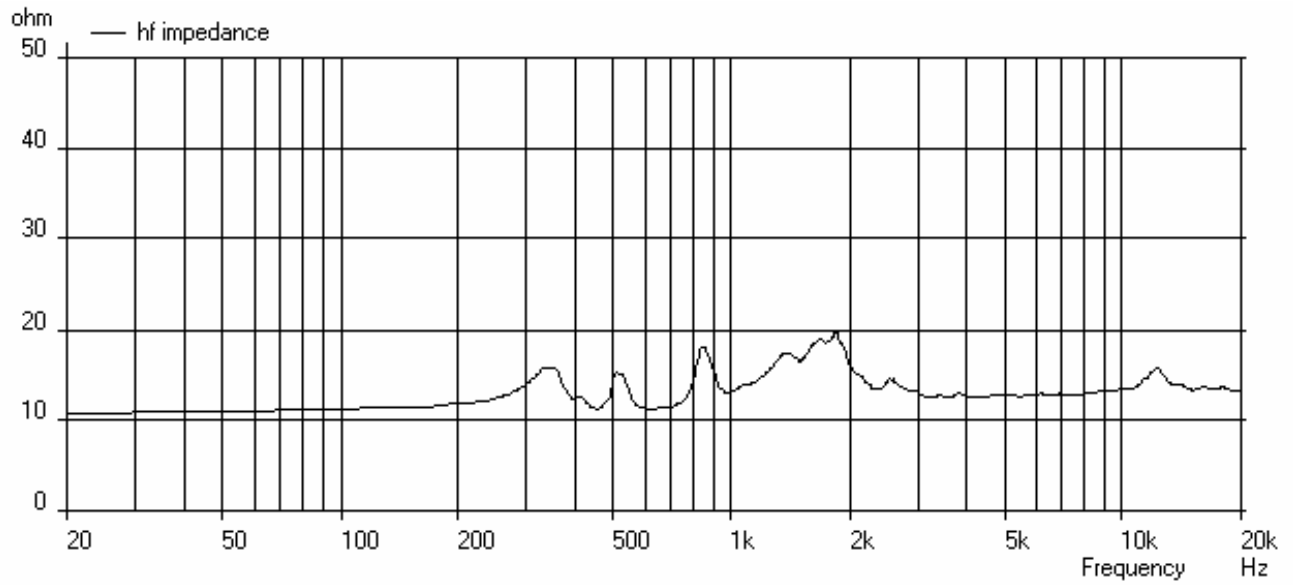

## FREQUENCY RESPONSE – Passive (iQ 10P)

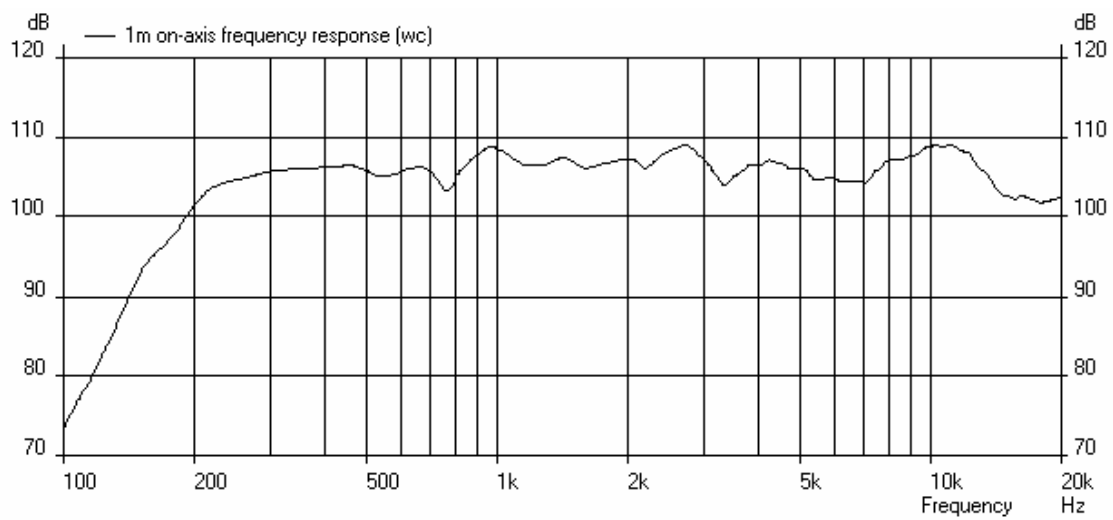

System Frequency Response @ 1m on axis (iQ 10P)

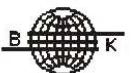



## iQ 10P INPUT IMPEDANCE

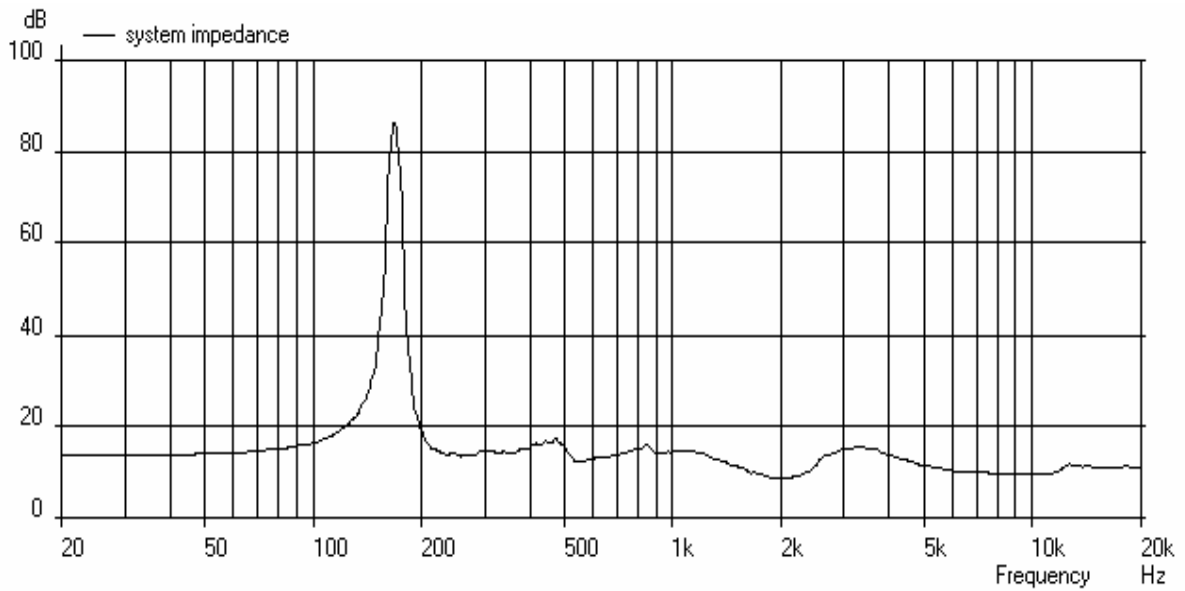

A comprehensive range of measurements including off axis frequency response curves, octave & third octave polar diagrams (single & two cabinet arrays) and beamwidth plots as well as Ease™ data can be downloaded from <http://www.tannoy.com/>

## 11. Technical Specifications

Frequency Response (1) +/- 3dB	180Hz – 19kHz	
Nominal Dispersion	60° × 40° (H × V)	
Maximum SPL @ 1m (2)	129dB Average (2)	135dB Peak (10ms)
Driver Complement	1 x 250mm (10") PowerDual™	

Components	iQ 10 – Midrange	iQ 10 – High Frequency	iQ 10P - System
Frequency Band (3)	180Hz – 2.77kHz	2.77kHz – 19kHz	180Hz – 19kHz
Sensitivity (1)	107dB	110dB	107dB
Power Handling (2)	175W (Average) 50W (Programme) 700W (Peak)	50W (Average) 100W (Programme) 200W (Peak)	175W (average) 350W (Programme) 700W (Peak)
Impedance	16Ω	16Ω	16Ω
<b>DI Averaged (PCQ)</b>		11.0, 500 Hz - 16 kHz	
	<b>@ 1kHz (ISO)</b>	12.6	
	<b>@ 2kHz (ISO)</b>	12.2	
	<b>@ 4kHz (ISO)</b>	9.5	
	<b>@ 8kHz (ISO)</b>	11.5	
	<b>@ 16kHz (ISO)</b>	12.3	
<b>Q Averaged (PCQ)</b>		13.5, 500 Hz - 16 kHz	
	<b>@ 1kHz (ISO)</b>	18.3	
	<b>@ 2kHz (ISO)</b>	16.7	
	<b>@ 4kHz (ISO)</b>	8.8	
	<b>@ 8kHz (ISO)</b>	14	
	<b>@ 16kHz (ISO)</b>	16.9	
<b>Crossover (Passive version only)</b>	Passive 2.6kHz 3rd order high pass, 2 <sup>nd</sup> order low pass		
Finish iQ10	Dark Grey		
Finish iQ10C	Textured black paint (optional in white)		
Connectors	2 × Speakon NL4MP in/out		
Enclosure iQ10	Moulded, weatherproof		
Enclosure iQ10C	18mm multi-ply birch plywood		
Fittings iQ10	Yoke Mount		
Fittings iQ10C	8 x M10 inserts & 2 pullback points		
Dimensions iQ10	470mm (H) × 595mm (W) × 494mm (D)		
Dimensions iQ10C			
Weight iQ10	17kg (37.5lb)		
Weight iQ10C			
Shipping Dimensions iQ10	600mm (H) × 680mm (W) × 540mm (D)		
Shipping Dimensions iQ10C			
Shipping Weight iQ10	22kg (48.5lb)		
Shipping Weight iQ10C			
Options	Passive X-over Version iQ 10P & iQ 10PC		

### NOTES:

- (1) Average over stated bandwidth. Measured at 1m on axis.
- (2) Long term power handling capacity as defined in EIA standard RS - 426A.
- (3) Unweighted pink noise input, measured at 1m in an anechoic chamber

The iQ 10 is designed for use with the Tannoy TDX1 & TDX2 digital system controller, which provide a preset configuration of Crossover frequencies, relative output levels, and system equalization for optimum performance. Should you intend using an alternative Loudspeaker management system, these parameters can be accessed from the Tannoy website – [www.tannoy.com](http://www.tannoy.com) - or can be found in the iQ 10 user manual.

Tannoy operates a policy of continuous research and development. The introduction of new materials or manufacturing methods will always equal or exceed the publish which Tannoy reserves the right to alter without prior notice.  
Please verify the latest specifications when dealing with critical applications.

**Unique Funktion One Axhead Technology (UK patent number GB2270606) is incorporated into Tannov iQ Series SuperDual™ products by agreement with Funktion One Research**

## 12. System Configurations & OEM Controllers

### Passive or Biamp?

The iQ 10 is supplied as standard for bi-amp operation, therefore there is no internal passive crossover network between the mid & hf units. **The Bi-amp controller parameters below must be adhered to for optimum performance.**

An optional iQ 10P (passive version) can be ordered if (part no. 8001 2210)

A loudspeaker driven in Biamp mode offers a number of performance advantages, such as increased system headroom. Audio program material is made up of many different frequencies and harmonics. In music material, most of the energy is in the low frequencies, with less in the highs. When both high and low frequencies are present in a signal, the stronger low frequencies can use up amp power, leaving little or no reserve for the highs, so they are more likely to cause the power amplifier to clip. In a Biamp driven system, a smaller amp can handle high frequencies, LF amp clipping is less of a factor, and less overall amplifier capacity is needed due to the efficiency improvement in the absence of a passive crossover.

### Bi-amp System Parameters (iQ 10 & iQ 10C)

Parameter	Unit/Name	Mid Section	High Section
Gain	(dB)	0	0
Delay*	(ms)	3.669	3.578
Polarity		Positive	Positive
HPF	Freq (Hz)	180	2820
	Slope (dB/oct)	24	24
	Filter Shape	Linkwitz Riley	Linkwitz Riley
LPF	Freq (Hz)	2820	Thru
	Slope (dB/oct)	24	NA
	Filter Shape	Linkwitz Riley	NA
PEQ 1	Freq (Hz)	354	7080
	Level (dB)	+1.7	+5
	Type	Parametric	Parametric
	Q / Bandwidth	0.8 / 1.25	3.1 / 0.32
PEQ 2	Freq (Hz)	1120	17800
	Level (dB)	-2	+6
	Type	Parametric	Parametric
	Q / Bandwidth	2 / 0.5	2.5 / 0.4

\*Note Apply only when an iQ 10 is stacked directly on top of an iQ 18B Sub bass. Otherwise apply 0.1ms to the Midrange and then any other required delay to compensate for distance between relevant sources.

### Passive System Parameters (iQ 10P & iQ 10PC)

With the vast array of digital loudspeaker management systems available it is inevitable that the user may opt to use a controller other than the TDX1 or TDX2 as part of a large scale integrated system. Use the parameters in the table below for optimised performance:-

Parameter	Unit/Name	
Gain	(dB)	User definable
Delay *	(ms)	3.58
Polarity		Positive
HPF	Freq (Hz)	180
	Slope (dB/oct)	24
	Filter Shape	Linkwitz Riley
LPF	Freq (Hz)	Thru
	Slope (dB/oct)	NA
	Filter Shape	NA
PEQ 1	Freq (Hz)	2000
	Level (dB)	-4
	Type	Parametric
	Q / Bandwidth	0.8 / 1.25

\*Note Apply only when an iQ 10 is stacked directly on top of an iQ 18 Sub bass. Otherwise only apply delay to compensate for distance between relevant sources.

**13. iQ 10 Service Parts and Accessories**

<b>Part Number</b>	<b>Description</b>
7900 0607	Driver Kit Type 2519 (LF)
7900 0609	Recone Kit Type 2519 (LF)
7900 0608	Driver Kit Type 0278 (HF)
7900 0610	Diaphragm Type 0278 (HF)
8001 2820	VEB – Secur ET – Eyebolts M10
8001 2850	Secur ET VPC Pole Clamp
8000 3630	TDX1 Digital System Controller 60-250V – UK
8000 3631	TDX1 Digital System Controller 60-250V – EUR
8000 3632	TDX1 Digital System Controller 60-250V – USA
8000 0727	TDX2 Digital loudspeaker management system 60-250V - UK
8000 0728	TDX2 Digital loudspeaker management system 60-250V - EUR
8000 0729	TDX2 Digital loudspeaker management system 60-250V – USA

**14. Warranty**

No maintenance of the iQ 10 loudspeaker is necessary.

All Tannoy professional loudspeaker products are covered by a 5 year warranty from the date of manufacture subject to the absence of misuse, overload or accidental damage. Claims will not be considered if the serial number has been altered or removed. A Tannoy Professional dealer or service agent should only carry out work under warranty. This warranty in no way affects your statutory rights. For further information, please contact your dealer or distributor in your country. If you cannot locate your distributor, please contact Customer Services, Tannoy Ltd at the address given below.

**Customer Services**  
**Tannoy Ltd.**  
**Coatbridge**  
**ML5 4TF**  
**Scotland**

Telephone: 01236 420199 (National)  
+44 1236 420199 (International)  
Fax: 01236 428230 (National)  
+44 1236 428230 (International)  
E-Mail: [service@tannoy.com](mailto:service@tannoy.com)  
Website: [www.tannoy.com](http://www.tannoy.com)

DO NOT SHIP ANY PRODUCT TO TANNOY WITHOUT PREVIOUS AUTHORISATION

Our policy commits us to incorporating improvements to our products through continuous research and development. Please confirm current specifications for critical applications with your supplier.

## 15. Declaration of Conformity

---



The following apparatus is/are manufactured in the United Kingdom by Tannoy Ltd of Rosehall Industrial estate, Coatbridge, Scotland, ML5 4TF and conform(s) to the protection requirements of the European Electromagnetic Compatibility Standards and Directives relevant to Domestic Electrical Equipment. The apparatus is designed and constructed such that electromagnetic disturbances generated do not exceed levels allowing radio and telecommunications equipment and other apparatus to operate as intended, and, the apparatus has an adequate level of intrinsic immunity to electromagnetic disturbance to enable operation as specified and intended. This Equipment conforms to the requirements of the EMC Directive 89/336/EEC, amended by 92/31/EEC and 93/68/EEC and the requirements of the low voltage directive 73/23/EEC, amended by 93/68/EEC.

Details of the Apparatus:

Tannoy Contractor Loudspeaker

Associated Technical File:

Model Number: iQ10

Applicable Standards:

EMCIQ10

EN 55103 –1:1996 Emission

EN 55103 –2:1996 Immunity

Electrical Safety:

EN 60065:1993

Signed:

A handwritten signature in black ink, appearing to read 'G. Hawley', with a long horizontal stroke extending to the right.

Position:

Engineering Director – Professional Products

Tannoy Professional

Date:

10/10/2004

For Tannoy Ltd



B



---

**Tannoy Loudspeakers are manufactured in Great Britain by:**

**Tannoy Ltd, Rosehall Industrial Estate, Coatbridge,  
Strathclyde, ML5 4TF, SCOTLAND  
Telephone: +44 (0) 1236 420199  
Fax: +44 (0)1236 428230**

Tannoy North America Inc, Suite 1. 335 Gage Avenue, Kitchener, Ontario, CANADA, N2M 5E1  
Telephone: (519) 745 1158  
Fax: (519) 745 2364

Issue 1.0 Part No. 6481 0429

GH June 27, 2004