

SMART TERMINAL EST555Z

User's Manual DMC10 Package

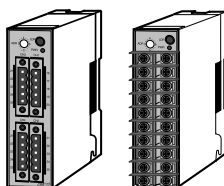
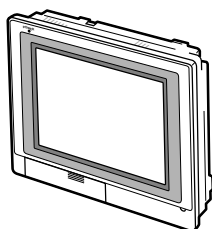

Thank you for purchasing the DMC10 Package for the EST555Z. This manual contains information for ensuring correct use of the EST555Z. It also provides necessary information for installation, maintenance and troubleshooting. This manual should be read by those who design and maintain devices that use the EST555Z. Be sure to keep this manual nearby for handy reference.

Yamatake Corporation

RESTRICTIONS ON USE

When using this product in applications that require particular safety or when using this product in important facilities, pay attention to the safety of the overall system and equipment. For example, install fail-safe mechanisms, carry out redundancy checks and periodic inspections, and adopt other appropriate safety measures as required.

NOTICE

Be sure that the user receives this manual before the product is used.

Copying or duplicating this user's manual in part or in whole is forbidden. The information and specifications in this manual are subject to change without notice.

Considerable effort has been made to ensure that this manual is free from inaccuracies and omissions. If you should find an error or omission, please contact Yamatake Corporation.

In no event is Yamatake Corporation liable to anyone for any indirect, special or consequential damages as a result of using this product.

©2001 Yamatake Corporation ALL RIGHTS RESERVED

The SMART TERMINAL™ is a trademark of Yamatake Corporation in Japan.

The Role of This Manual

Outline of EST555Z Manuals

The below 6 manuals are provided to cover a range of EST555Z-related topics. Use the manual that best fits your application. In the event such a manual is not available, contact us or your local EST555Z dealer.

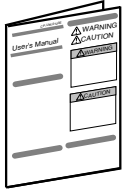

SMART TERMINAL EST555Z User's Manual Manual No. CP-UM-5229E

This manual is packaged with the EST555Z body.

This manual should be read by those who produce units that use the Smart Terminal.

This manual contains safety precautions when using the Smart Terminal, installation methods, and descriptions for wiring the power supply and signal lines.

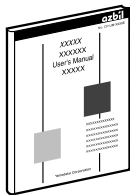

SMART TERMINAL EST555Z User's Manual Installation

Manual No. CP-SP-1103E

This manual should be read by those who use the EST555Z to design units and those in charge of maintenance.

This manual describes safety cautions when using the Smart Terminal, how to install for incorporating into units, wiring methods, maintenance and inspection, troubleshooting, and hardware specifications.



SMART TERMINAL EST-Z Series User's Manual Application Preparation

Manual No. CP-SP-1088E

This manual should be read by those who design screens that are displayed on the EST-Z Series and operations.

This manual describes the environment of the personal computer on which AP Editor can be used, installation methods, startup, system settings, file operations, printing, how to paste smart objects, and other AP Editor operations.

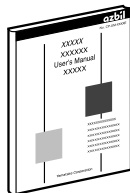

SMART TERMINAL EST-Z Series User's Manual Smart Object Library

Manual No. CP-SP-1089E

Graphic elements that have functions for displaying on the EST-Z Series are called "smart objects."

This manual describes the concept of smart objects and the functions of each smart object.

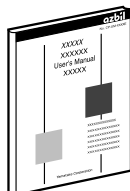

SMART TERMINAL EST-Z Series User's Manual Communications Connection

Manual No. CP-SP-1090E

This manual should be read by those who combine the EST-Z Series with PLCs made by other manufacturers and dedicated board computers to build systems. This manual describes how to connect to PLCs, address maps that correspond to PLCs, how to paste smart objects, drawing, and other operations and settings required for making applications using PLCs.

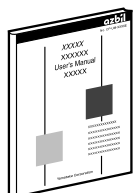

**SMART TERMINAL EST555Z User's Manual
DMC10 Package**

Manual No. CP-SP-1124E

This manual.

This package is used when constructing systems by connecting the EST555Z to Yamatake Distributed Multi-channel Controller DMC10.

This manual describes the specifications of the software package, how to use the package, how to install the software, and how to operate the software.

Organization of This User's Manual

This manual is organized as follows:

Chapter 1. SYSTEM CONFIGURATION

This chapter describes the system configuration of the EST555Z with a modular type controller DMC10 when using the Package.

Chapter 2. FUNCTIONAL OUTLINE

This chapter describes the outline of the various functions of the Package.

Chapter 3. COMMUNICATION CONNECTIONS

This chapter describes how to connect the EST555Z, the DMC10, and the CMC10B. For further details, see also the manuals of the DMC10 and the CMC10B.

Chapter 4. COMMUNICATION SETUP

This chapter describes the communication parameters and how to configure the communication addresses.

Chapter 5. HOW TO USE THE PACKAGE

This chapter describes how to install the Package and how to download it to the EST555Z, in addition to providing information on configuration that should be performed before using the Package. Be sure to read this chapter and perform the necessary configuration before using the Package.

Chapter 6. DMC10 SETUP AND MONITORING

This chapter describes items that can be setup and monitored using the Package during operation, and provides screen flow diagrams.

Chapter 7. USAGE EXAMPLES - GATEWAY AND CONTROL SWITCH

This chapter describes data exchange with the PLC using the gateway function of the EST555Z, and RUN/READY change of the DMC10 using the control switch.

Chapter 8. COMBINED USE WITH USER APPLICATION

The Package can be used with a user-application created by the user. This chapter describes how to use the Package with a user-application.

Chapter 9. TROUBLESHOOTING

This chapter describes how to remedy problems that might occur.

Contents

The Role of This Manual	
Organization of This User's Manual	
Conventions Used in This Manual	

Chapter 1. SYSTEM CONFIGURATION

■ Direct-link and CMC-link	1-1
■ User Application and the Package	1-3

Chapter 2. FUNCTIONAL OUTLINE

■ Auto Device Assignment	2-1
■ Configuration Function	2-2
■ Monitor Function	2-3
■ SP Configuration	2-5
■ Control Switch	2-5
■ Configuration Setup	2-6

Chapter 3. COMMUNICATION CONNECTIONS

■ Direct-link	3-1
■ CMC-link	3-2

Chapter 4. COMMUNICATION SETUP

■ Configuration of the Communication Parameters	4-1
■ Configuration of the Communication Addresses	4-2

Chapter 5. HOW TO USE THE PACKAGE

5-1	Install the Package to the PC	5-1
5-2	Download the Package to EST555Z	5-2
	■ Download the Package only	5-2
	■ Download the User Application and the Package	5-4
	■ Download User-data of the Package	5-7
	■ Upload User-data of the Package	5-8
5-3	Configuration Setup of the Package	5-10
	■ Start Up the Package	5-10
	■ Auto Device Assignment	5-13
	■ Name Configuration	5-15
	■ Display Configuration	5-16
	■ Alarm Definition	5-20

Chapter 6. DMC10 SETUP AND MONITORING

- DMC10 Setup 6-1
- DMC10 Monitor 6-11
- DMC10 Alarm Monitor 6-15

Chapter 7. USAGE EXAMPLES - GATEWAY AND CONTROL SWITCH

- PLC Data Exchange with the EST555Z Gateway Function 7-1
- Control DMC10 using the Control Switch 7-7

Chapter 8. COMBINED USE WITH USER APPLICATION

Chapter 9. TROUBLESHOOTING

- Package Troubleshooting..... 9-1
- DMC10 Troubleshooting 9-2

Conventions Used in This Manual

The following conventions are used in this manual:

-  **Handling Precautions** : Handling Precautions indicate items that the user should pay attention to when handling the **DMC10 Package**.

-  **Note** : Notes indicate useful information that the user might benefit by knowing.

- (1), (2), (3) : Circled numbers indicate steps in a sequence or indicate corresponding parts in an explanation.

- >> : Indicates the result of an operation, the indication of the personal computer and the EST or the EST action after an operation.

- [A] [B] [C] etc. : This indicates a key on the personal computer's keyboard.

Chapter 1. SYSTEM CONFIGURATION

■ Direct-link and CMC-link

The DMC10 Package (hereinafter referred to as the Package) software is available in two versions, Direct-link version and CMC-link version. The user should select the appropriate one according to their application.

The Direct-link version is used when the number of DMC10 units to be connected is 15 or less and the EST555Z and the DMC10 are to be connected directly.

The CMC-link version is used when the number of DMC10 units to be connected is 16 or more. In this case, the EST555Z and the DMC10 are connected via a CMC10B. A maximum of 16 CMC10B units can be connected to the EST555Z and a maximum of 15 DMC10 can be connected to each CMC10B. A group of one CMC10B and the DMC10 units that are connected to it are called one “unit”.

! Handling Precautions

The event-output-module DMC10E is not counted in the number of units connected to the DMC10.

● System configuration of Direct-link

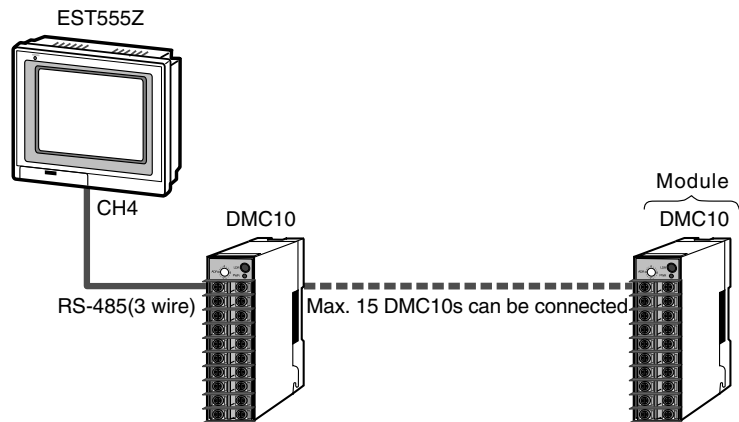

📖 Note

For the Direct-link version, the SDU10 (Compact Operation Unit for the DMC10) can be connected between the EST555Z and the DMC10. In this case, the device address of the SDU10 is required to be 0. For detail information, refer to the User's Manual, Compact Operation Unit SDU10 for Distributed Multi-channel Controller DMC10 User's Manual, (Manual No. CP-SP-1096E).

! Handling Precautions

- The DMC10 should be connected to CH4 of the EST555Z. CH1 to CH3 can not be used.
- When using the Package, equipment other than the DMC10 cannot be connected to CH4 of the EST555Z at the same time.

● System configuration of CMC-link

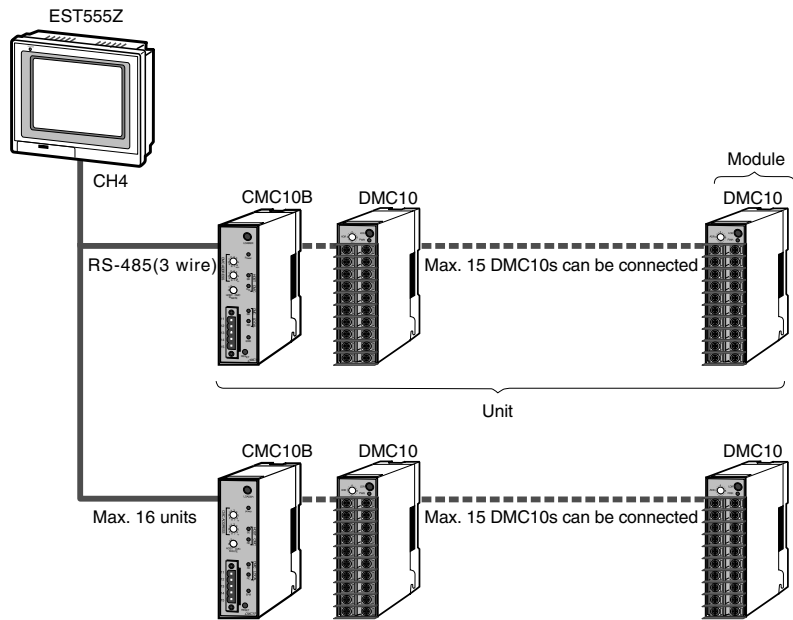

! Handling Precautions

- For the CMC-link version, the SDU10 (Compact Operation Unit for the DMC10) can not be connected.
- CMC10B should be connected to CH4 of the EST555Z. CH1 to CH3 can not be used.
- When connecting the CMC10B to CH4 of the EST555Z, other equipment can not be connected to this port.
- The configuration of the CMC10B such as Folder and Buffering Configuration are done automatically by the Package when Auto device assignment is performed. Configuration such as Buffering data definition can not be performed by the user. Do not change the configuration of the CMC10B after performing Auto device assignment. For the details of Auto device assignment, see 5-3 Configuration Setup of the Package.

📖 Note

The explanation in this manual is common to both the Direct-link version and CMC-link version. The screen examples are that of the CMC-link version, and where there is any difference between two versions, it is explained each time.

■ **User Application and the Package**

The user can use a User Application along with the Package.
For information on how to create a User Application, see the following manual: SMART TERMINAL EST-Z Series User's Manual Application Preparation (Manual No. CP-SP-1088E).
When operation starts after both the User Application and the Package have been downloaded, the No.1 screen (Panel 1) of the User Application starts first.
A Panel change switch (dedicated package change) should have been included in the User Application in advance.
For details, see Chapter 8. COMBINED USE WITH USER APPLICATION.

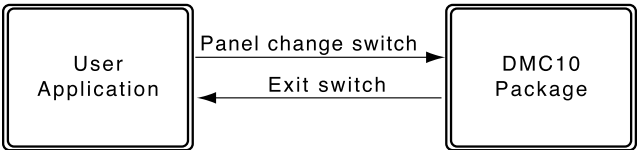

❗ **Handling Precautions**

When the [EST Information] of the DMC10 is [4] or less, the Package cannot be used.
Only the DMC10 with [EST Information] of [5], or later, can be used.
The EST information can be checked as follows with the DMC10s PC loader SLP-D10 : [Setup] → [Standard] → [Information] → [EST Information]

Chapter 2. FUNCTIONAL OUTLINE

This chapter describes the outline of the various functions of the Package.

■ Auto Device Assignment

The Package determines how many CMC10B and DMC10 units are connected to the EST555Z and automatically performs the device assignment. Information such as the model No. of the DMC10, which options are used, the PV input parameters, etc, are registered to the EST555Z by the Auto Device Assignment. Auto Device Assignment must be performed when starting up the system.

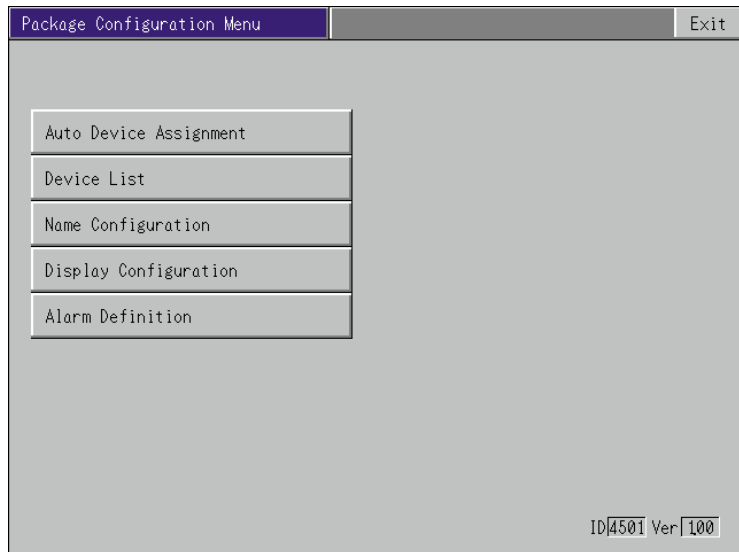

■ Configuration Function

The parameters that are necessary for general use of the DMC10 can be configured by the Package.

The following is a list of such parameters:

Functions	Type	Item	Remarks
Standard	PV inputs	Input type	
		Temp Unit	
		Decimal point position	
		PV range low limit	
		PV range high limit	
		PV bias	
		SP low limit	
		SP high limit	
		SP Down Ramp	
		SP Up Ramp	
	Control outputs	Control output	
		Control action	
		Time proportional cycle	
		Operation at AUTO/MANUAL change	
		Pre-set manual value	
		Output at Ready	
		Heat/Cool Deadzone	
	SP / Control parameter	SP	
		Proportional band (P)	
		Integral time (I)	
		Derivative time (D)	
Manual reset (RE)			
Option	Event	Type	
		Channel	
		Event Value (Main)	
		Event Value (Sub)	
		Hysteresis	
		Direct/Reverse	
		Standby	
		Output assignment 1 to 3	
		Logic	
		ON delay time	
		OFF delay time	
		Latch	
		Polarity (energizing/de-energizing)	
	CT Input functions	CT Input CH	
		Waiting time before measuring	
	RSW input functions	Type	
		Channel	
		Input assignment 1 to 3	
		Logic	
		Polarity	

Functions	Type	Item	Remarks
Option	AUX. output functions	Type	
		Channel	
		Output type	
		Value at 0% output	
		Value at 100% output	
Special functions		Multiple SP	
		Event special	
		RSW special	
		Remote SP	*2
		Heat/Cool	*1, *2
		Position Proportional Control	*1, *3

*1 Display only. Setting is not possible.

*2 DMC10D (High function model) only.

*3 Only applicable for DMC10 units which have Position Proportional/Module Control Model.

■ Monitor Function

The Package has the following Monitor functions:

● Module monitor

Monitors one DMC10 module at a time. The following functions are available:

- PV monitor
- SP monitor/change
- MV monitor/change (in MANUAL mode)
- RUN/READY status monitor/change
- AUTO/MANUAL mode monitor/change
- AT status monitor/change
- LOCAL/REMOTE status monitor/change
- input/output monitor
- alarm monitor
- basic trend of PV&SP and MV

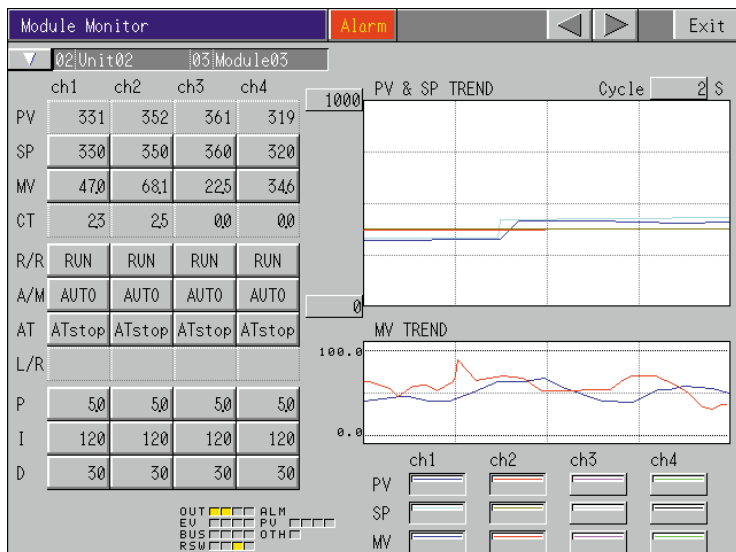

● Group monitor

All the DMC10 units within the same unit are monitored.
 2 items that are selected from the following list of items can be monitored by one screen, and a maximum of four screens can be defined:
 PV, SP, MV, CT, SP Sel, AUTO/MANUAL, RUN/READY, LOCAL/REMOTE, AT status.

Group Monitor												Alarm	▲	▼	◀	▶	Exit	
02 Unit02																		
01 Module01				02 Module02				03 Module03										
	ch1	ch2	ch3	ch4	ch1	ch2	ch3	ch4	ch1	ch2	ch3	ch4						
SP	200	200	200	200	200	200	200	200	200	200	200	200						
PV	199	200	201	200	200	200	201	200	200	200	198	200						
04 Module04				05 Module05				06 Module06										
	ch1	ch2	ch3	ch4	ch1	ch2	ch3	ch4	ch1	ch2	ch3	ch4						
SP	200	200	200	200	200	200	200	200	200	200	200	200						
PV	199	200	201	200	200	200	201	200	200	200	198	200						
07 Module07				08 Module08				09 Module09										
	ch1	ch2	ch3	ch4	ch1	ch2	ch3	ch4	ch1	ch2	ch3	ch4						
SP	200	200	200	200	200	200	200	200	200	200	200	200						
PV	199	200	201	200	200	200	201	200	200	200	198	200						
10 Module10				11 Module11				12 Module12										
	ch1	ch2	ch3	ch4	ch1	ch2	ch3	ch4	ch1	ch2	ch3	ch4						
SP	200	200	200	200	200	200	200	200	200	200	200	200						
PV	199	200	201	200	200	200	201	200	200	200	198	200						
13 Module13				14 Module14				15 Module15										
	ch1	ch2	ch3	ch4	ch1	ch2	ch3	ch4	ch1	ch2	ch3	ch4						
SP	200	200	200	200	200	200	200	200	200	200	200	200						
PV	199	200	201	200	200	200	201	200	200	200	198	200						

● Alarm monitor

The Package monitors the alarm status of all the connected DMC10 units. On the “Module Monitor” screen, “Group Monitor” screen, “Control Switch” screen and the “SP Configuration” screen, the Alarm lamp indicates whether alarms are occurring. The “Alarm List” screen and “Alarm Mod Detail” screen are also provided. The user can add user-set events as alarms, in addition to the PV input alarm, device alarm and communications error alarm.

Alarm Module Detail											Exit	
02 Unit02				03 Module03								
Comm	<input type="checkbox"/>	ROM	<input type="checkbox"/>	RAM	<input type="checkbox"/>	FB	<input type="checkbox"/>					
	ch1	ch2	ch3	ch4								
Hi	<input type="checkbox"/>	<input checked="" type="checkbox"/>	<input type="checkbox"/>	<input type="checkbox"/>							Hi Limit <input type="checkbox"/>	
Lo	<input type="checkbox"/>	<input type="checkbox"/>	<input type="checkbox"/>	<input type="checkbox"/>							Lo Limit <input type="checkbox"/>	
CJ/B	<input type="checkbox"/>	<input type="checkbox"/>	<input type="checkbox"/>	<input type="checkbox"/>								
A/D	<input type="checkbox"/>	<input type="checkbox"/>	<input type="checkbox"/>	<input type="checkbox"/>								

■ SP Configuration

The SPs of all the DMC10 units within the same unit are monitored.
SP can be set for each CH.

SP Configuration												Alarm	◀	▶	Exit
02 Unit02															
01 Module01				01 Module02				01 Module03							
ch1	ch2	ch3	ch4	ch1	ch2	ch3	ch4	ch1	ch2	ch3	ch4				
200	200	200	200	200	200	200	200	200	200	200	200				
01 Module04				01 Module05				01 Module06							
ch1	ch2	ch3	ch4	ch1	ch2	ch3	ch4	ch1	ch2	ch3	ch4				
200	200	200	200	200	200	200	200	200	200	200	200				
01 Module07				01 Module08				01 Module09							
ch1	ch2	ch3	ch4	ch1	ch2	ch3	ch4	ch1	ch2	ch3	ch4				
200	200	200	200	200	200	200	200	200	200	200	200				
01 Module10				01 Module11				01 Module12							
ch1	ch2	ch3	ch4	ch1	ch2	ch3	ch4	ch1	ch2	ch3	ch4				
200	200	200	200	200	200	200	200	200	200	200	200				
01 Module13				01 Module14				01 Module15							
ch1	ch2	ch3	ch4	ch1	ch2	ch3	ch4	ch1	ch2	ch3	ch4				
200	200	200	200	200	200	200	200	200	200	200	200				

■ Control Switch

The Control switch enables the user to select a DMC10 channel and change a group of SPs with one operation, or to change the modes such as RUN/READY, AUTO/MANUAL, AT-stop/-start with one operation.

The user can define up to 8 control switches.

Control Switch	Alarm	Exit
All Run		
All Ready		
SP No.1		
SP No.2		
SP No.3		
SP No.4		

Note

The Control switch definition can be made in [Package Configuration Menu] → [Display Configuration]. For detail information, refer to the ●Control switch definition display (p. 5-18).

■ Configuration Setup

The user can set the configuration according to the application.

● Name configuration

Unit name, module name, and CH name can be configured for the CMC10B and DMC10 units which were registered by the Auto device assignment. (The unit name can be set only with the CMC-link version.)

The initial names are Unit01, Module01, ch1, etc.

● Display configuration

Unused functions can be deleted from the menus on the screen.

Functions such as SP change and Mode change can be disabled.

● Alarm definition

The Package monitors DMC10 alarms such as PV input alarm, device alarm, and communications alarm.

The user can add the user-defined DMC10 events to the alarms.

Chapter 3. COMMUNICATION CONNECTIONS

■ Direct-link

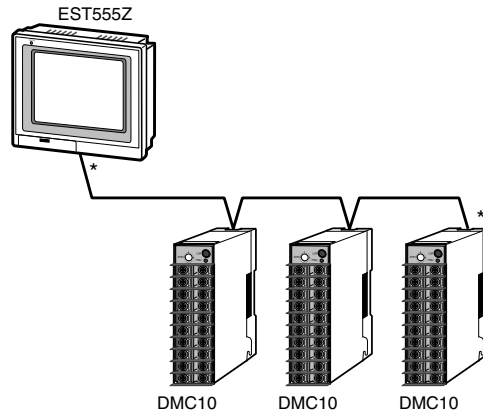

* Do not connect a terminating resistor at both ends of transmission line.

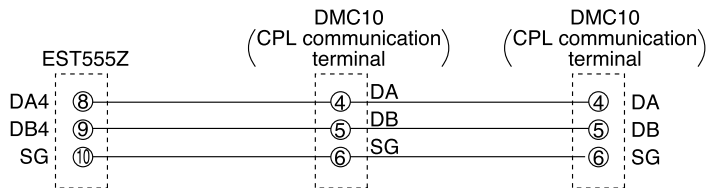

! Handling Precautions

- When linking two or more DMC10s, ensure that the communications disconnection switch is set to the “CONNECT→” side. (Factory default)
In this case, wiring is not necessary.
For details, refer to the following manual:
Distributed Multi-channel Controller DMC10 Description of Functional Manual (Manual No. CP-UM-5143E)
- The DMC10 has a built-in resistance equivalent to a terminating resistor. Do not connect an external terminating resistor.
- Do not connect a terminating resistor externally even when the SDU10 (Compact Operation Unit for the DMC10) is connected between the EST555Z and the DMC10.

■ CMC-link

● Connecting EST555Z and CMC10B

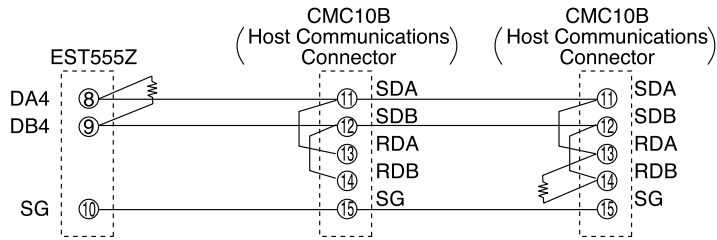
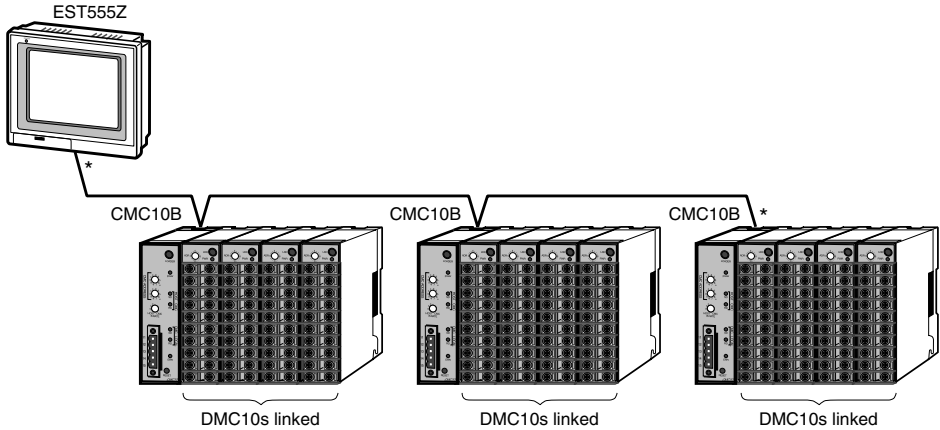

● Connecting CMC10B and DMC10

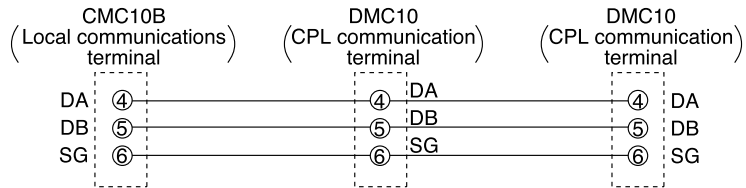

! Handling Precautions

- When linking the DMC10 to a CMC10B, or two or more DMC10s ensure that the communication disconnection switch is set to the “CONNECT→” side(Factory default).
For details, refer to the following manuals.
Communication Controller CMC10B (CPL/CPL Converter)
User's Manual (Design Manual) Manual No.CP-SP-1064E
Module Controller DMC10 Description of Function Manual
(Manual No. CP-UM-5143E)
- Connect terminating resistor (120 to 150 Ω, 1/2W) to both ends of the EST555Z and the CMC10B.
- The DMC10 has a built-in resistance equivalent to a terminating resistor. Do not connect an external terminating resistor.

Chapter 4. COMMUNICATION SETUP

■ Configuration of the Communication Parameters

The communication parameters of the Package are as follows:

Baud rate : 19200 bps

Data format : bit length 8, even parity, 1 stop bit

● Configuration of EST555Z

The communication parameters are set automatically in the EST555Z when a Package is downloaded to it.

● Configuration of DMC10

The DMC10s communication parameters are set as above when shipped from the factory. To confirm, open the “Communication” item with the DMC10 PC loader. The settings should be as follows:

Baud rate : 3 (19200 bps)

Data format : 0 (8bit/ even parity/ 1 stop bit)

● Configuration of CMC10B (CMC-link version only)

The CMC10B requires two types of communication configuration; “Host Communications Setup” to connect with the EST555Z and “Local Communications Setup” to connect with the DMC10.

The transmission speed of the “Host Communications Setup” is set by the rotary switch on the CMC10Bs front panel.

Rotary Switch HOST↔CMC B.RATE : 2 (19200bps)

! Handling Precautions

The new setting of the CMC10Bs rotary switch becomes effective after switching the power OFF, then ON again.

Other conditions are set as above when shipping from the factory. To confirm, use the CMC10B PC loader. The settings should be as follows:

• Host Communication

Data format : 0 (8bit/ even parity/ 1 stop bit)

• Local Communication

Baud rate : 2 (19200 bps)

Data format : 0 (8bit/ even parity/ 1 stop bit)

■ Configuration of the Communication Addresses

● Configuration of EST555Z

The EST555Z does not require any communication address configuration.

● Configuration of DMC10 (Direct-link)

For Direct-link, set the communication address rotary switch “ADR” of the 1st through to 15th (max.) DMC10 for 1 to 15 (1 to F), respectively.

! Handling Precautions

- Each DMC10 must have a different communication address.
If the number of the DMC10 units connected is 14 or less, one or more communication address can be reserved for the additional installation of units in the future.
For example, the DMC10 communication address can be set as follows:
1, 2, 5...
Unused addresses in this example are available for future use.
- The new setting of the DMC10s rotary switch becomes effective after switching the power OFF, then ON again.

● Configuration of CMC10B/DMC10 (CMC-link)

For CMC-link,

- (1) Set the [CMC ADDRESS] rotary switches on the front face of the 1st through to 16th(max.) CMC10B for 01 to 16, respectively. The Address is set by the two rotary switches, [x 10] and [x 1]. When setting an address of less than 10, the [x 10] switch must be set for 0.
- (2) Set the communication address rotary switch [ADR] of the 1st through to 15th (max.) DMC10 that are connected to CMC10B for 1 to 15 (1 to F), respectively.

! Handling Precautions

- Each DMC10 that is connected to the same CMC10B must have a different communication address.
If the number of the DMC10 connected is 14 or less, one or more communication address can be reserved for the additional installation of units in the future.
For example, The DMC10 communication address can be set as follows: 1, 2, 5...
Unused addresses in this example are available for the future use.
- A DMC10 that is connected to a different CMC10B can use the same communication address.
- The new settings of the CMC10Bs and DMC10s rotary switches become effective after switching the power OFF, then ON again.

Chapter 5. HOW TO USE THE PACKAGE

5 - 1 Install the Package to the PC

In order to install the Package, the AP Editor should have been installed in the PC. For information on the installation of the AP editor, see the following manual:

SMART TERMINAL EST-Z Series User's Manual Application Preparation (Manual No.CP-SP-1088E)

This section describes how to install the Package to the AP Editor in the PC.

- (1) Insert the Package floppy disc to the floppy drive of the PC.
Double-click [My Computer].
- (2) Right-click the floppy drive icon and select [Open] from the pull-down menu.

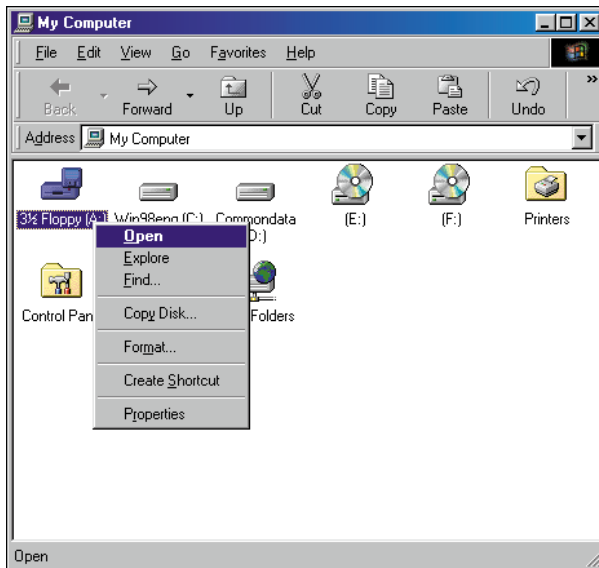

- (3) Files on the floppy disc are displayed. Double-click [Setup.exe].

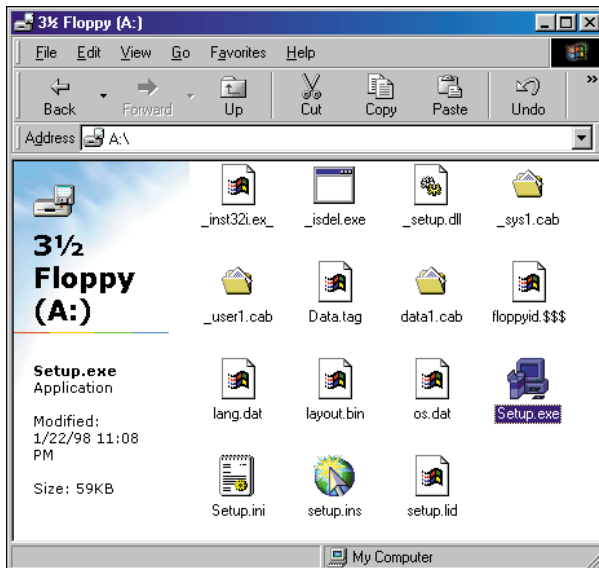

- (4) Setup screen will be displayed.
- (5) Follow the instructions on the screen to continue the setup.

5 - 2 Download the Package to EST555Z

■ Download the Package only

! Handling Precautions

- All the EST555Z applications will be initialized by performing the downloading described in this section.
- By downloading the Package again to an EST555Z in which the Package has already been downloaded, the configuration will be initialized and any settings the user has made will be lost. The items to be initialized are all the items described in 5-3 Configuration Setup of the Package (p.5-10).

(1) Connect the PC and the EST555Z and turn on the power of the EST555Z.

(2) Startup the AP Editor.

Without opening any files, click [Online] in the menu-bar → [Download from PC to EST] → [Download Dedicated Package].

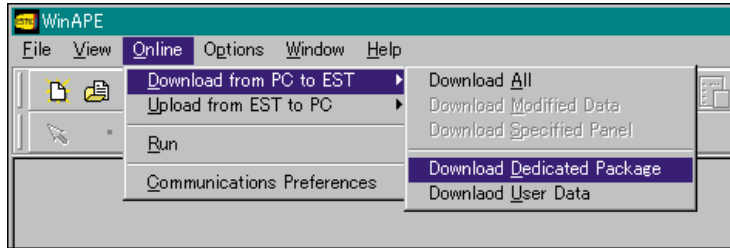

(3) Select the Package.

Select either the Direct-link or the CMC-link and click [OK].

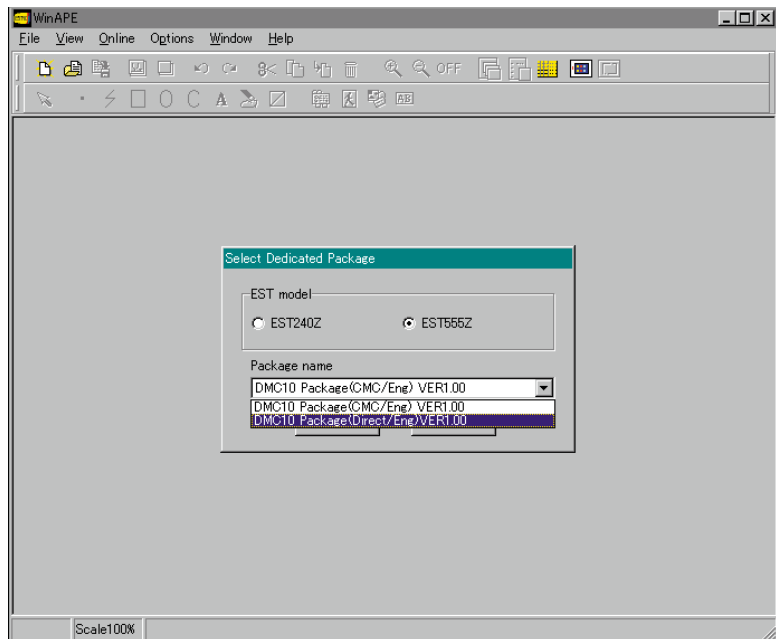

(4) Download the Package.

Download will begin after [OK] has been clicked.

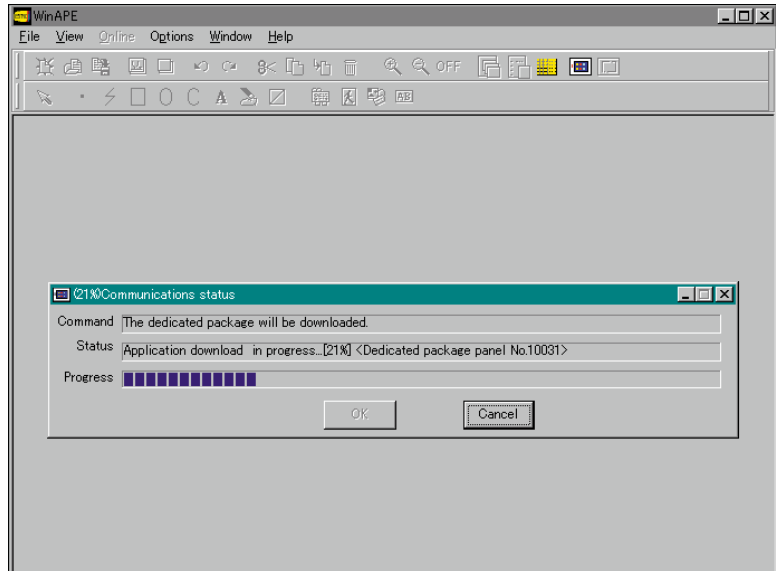

When the download has been completed, the following screen will be displayed:

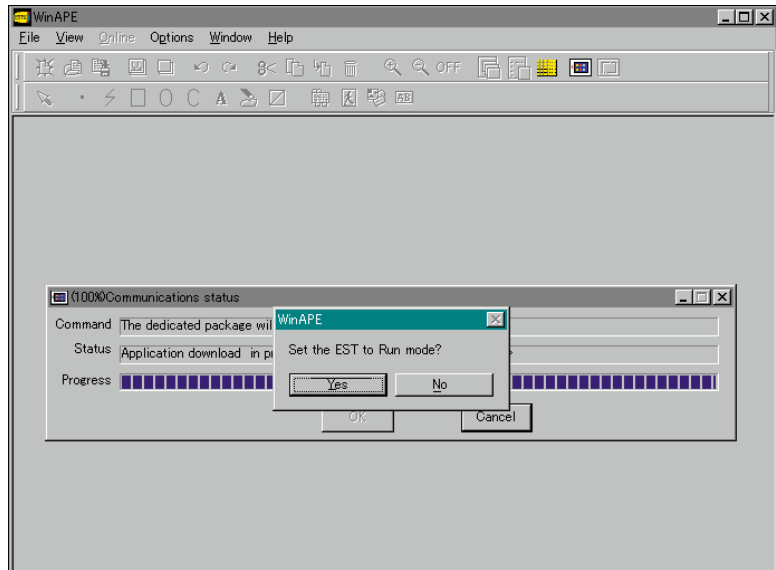

If you want to start the EST, select [Yes].

■ Download the User Application and the Package

! Handling Precautions

- If the Package has not already been downloaded to the EST555Z, the Package will be downloaded along with the User application by performing the download described in this section. If the Package has already been downloaded, only the User application will be downloaded.
- If downloading a User application only, the Package will be deleted. By downloading the Package again, the configuration will be initialized and any settings the user has made will be lost. The items which will be initialized are all the items described in 5-3 Configuration Setup of the Package (p.5-10).

(1) Connect the PC and the EST555Z and turn on the power of the EST555Z.

(2) Startup the AP Editor and create a User application.

For information on how to create a User application, see the following manual:
SMART TERMINAL EST-Z Series User's Manual Application Preparation (Manual No.CP-SP-1088E)

(3) Setup the Package.

Open [Configuration Information] → [General] from the application manager.

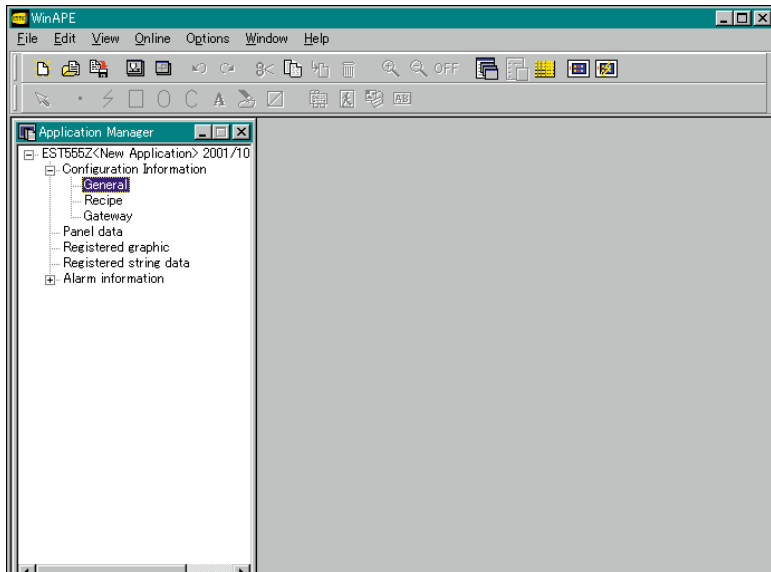

(4) Setup the options.

Click on [Package/Option] and select either the Direct-link or the CMC-link.
Click [OK].

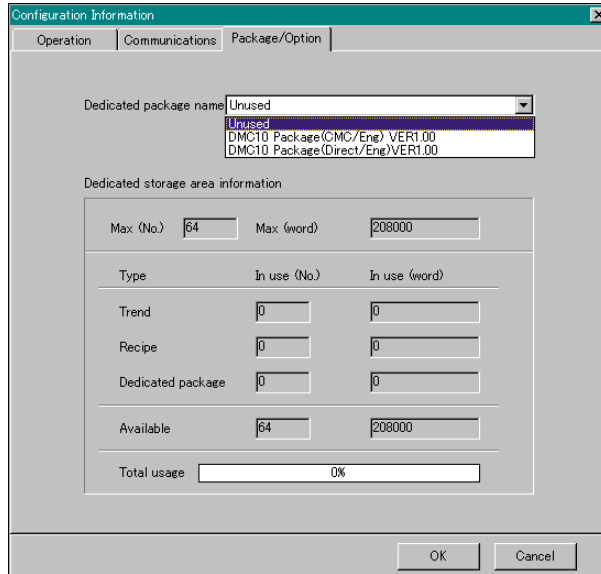

By clicking [OK], the communication settings of CH4 will be automatically changed according to the selected Package.

(5) Save the file.

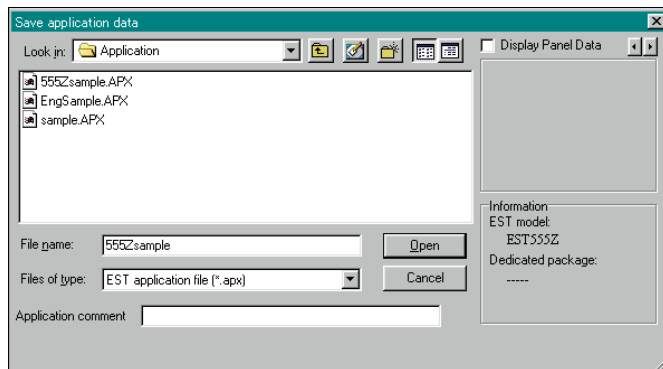

(6) Download the application.

Click [Online] in the menu-bar → [Download from PC to EST] → [Download All].

Follow the messages on the screen to perform the download:

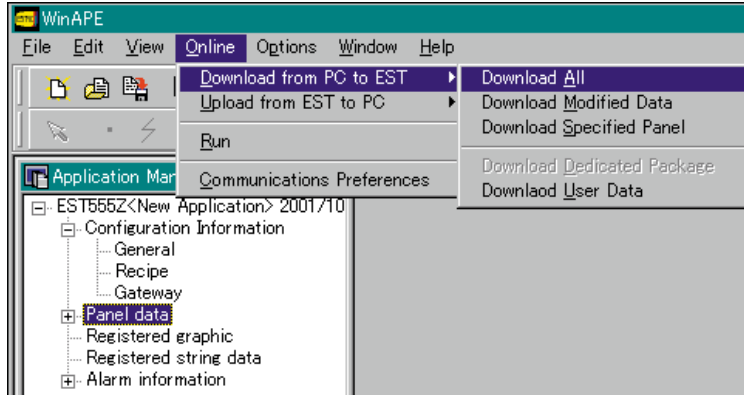

When the download has been completed, the following screen will be displayed:

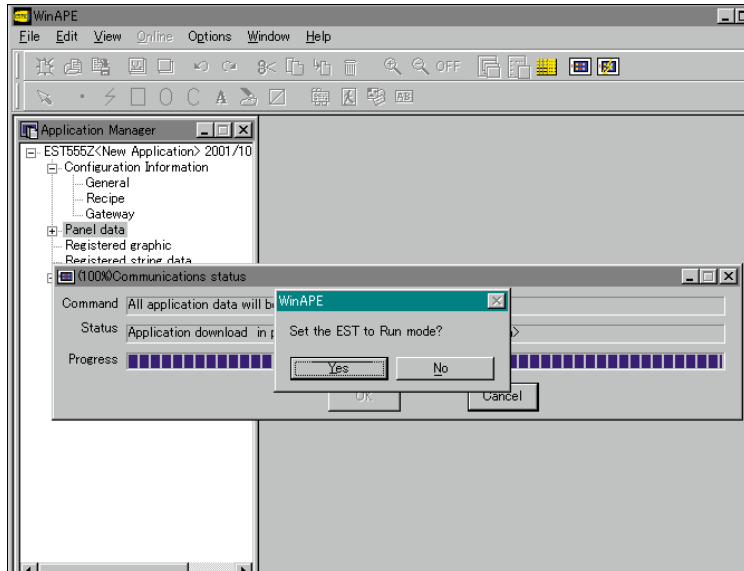

If you want to start the EST, select [Yes].

■ Download User-data of the Package

This section describes how to download the User-data (the data set by the user) of the Package such as Display Configuration and Name Configuration.

Use the User-data that has been uploaded from the EST.

- (1) Click [Online] in the menu bar → [Download from PC to EST] → [Download User Data].

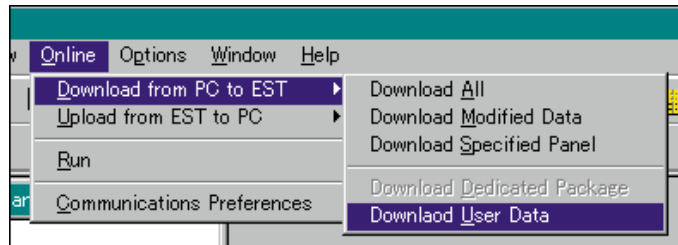

>> The following window will be displayed:

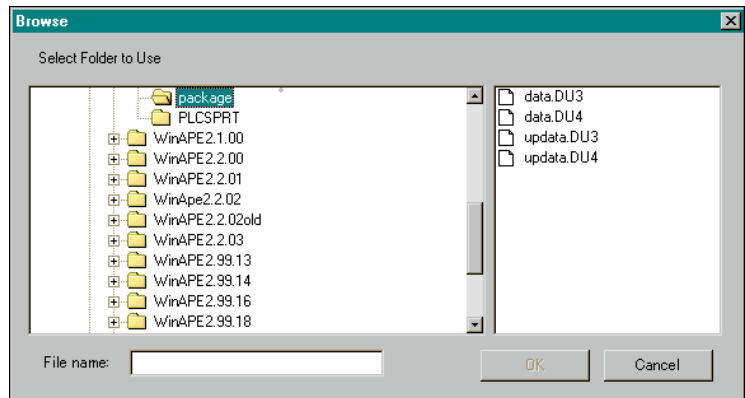

- (2) User-data select dialog will be displayed after selecting the file.

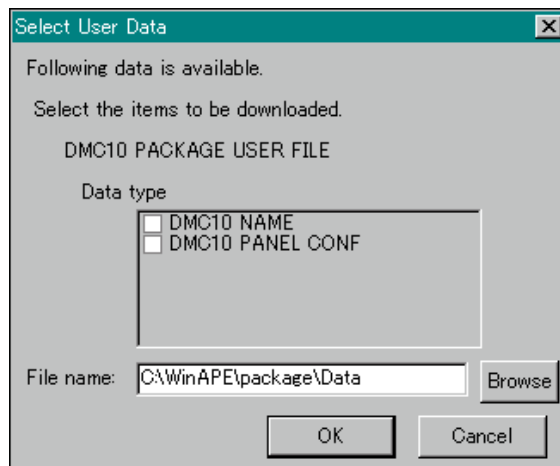

- **Data type** : Items that can be downloaded are displayed. Select the item to download and mark the check box.
- **File name** : File names to download are displayed.
- **Browse** : Click this button to display the file select window to change the file to download.

(3) Click [OK]. “Communications Status” screen will be displayed.

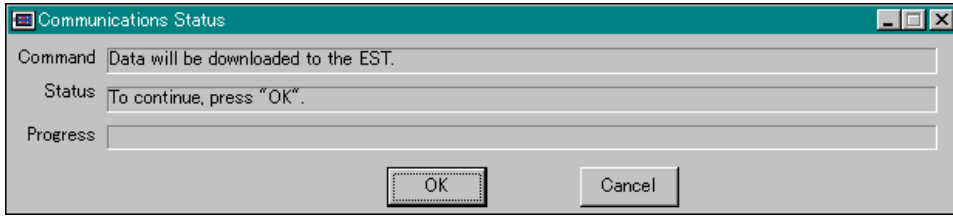

>> Click [OK]. Download will be executed.

! Handling Precautions

If the package has not been installed, downloading of the User-data of the Package is not possible.

■ Upload User-data of the Package

This section describes how to upload the User-data of the Package (already downloaded) in the EST such as Display Configuration and Name Configuration.

(1) Click [Online] in the menu bar → [Upload from EST to PC] → [Upload User Data].

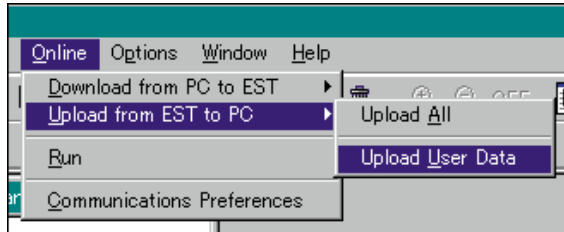

>>User-data select dialog will be displayed.

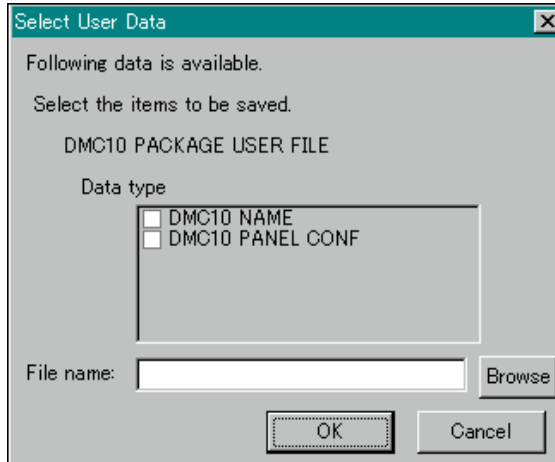

- Data type : Items that can be uploaded are displayed. Select the item to upload and mark the check box.
- File name : Input the file name for the uploaded data. The default folder is the one in which the package is installed.
- Browse : Click this button to display the file select window to change where to save the uploaded data.

(2) Click [OK]. "Communications Status" screen will be displayed.

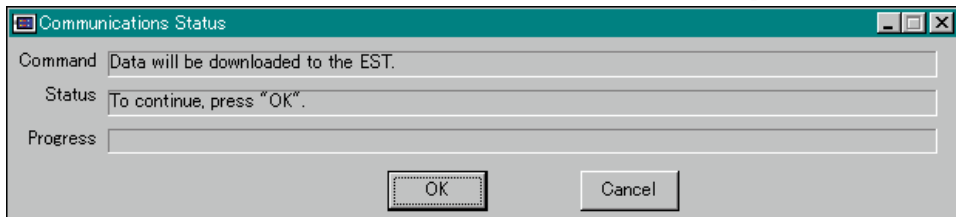

>> Click [OK]. Upload will be executed.

! Handling Precautions

- If the package has not been installed, uploading the User-data of the Package is not possible.
- Do not edit the uploaded data other than by using the EST. Otherwise, the package may not function correctly after such edited data has been downloaded.

5 - 3 Configuration Setup of the Package

After downloading the Package, the user should perform the necessary configuration in order to use the Package.

- **Auto device assignment**

The device configuration of the CMC10B and the DMC10 that are connected to the EST555Z are registered to the EST555Z by the Auto Device Assignment. This must be performed when starting up the system or when the basic parameters of the DMC10 have been changed by PC loader.

- **Name configuration**

Unit names can be given to the CMC10B, and module names and channel names can be given to the DMC10.

- **Display configuration**

The user can choose the necessary display functions. Display Configuration data can be uploaded/downloaded as User-data.

- **Alarm definition**

The DMC10 events specified by the user can be added to the DMC10 Alarm monitoring.



Note

Although the Auto device assignment must be performed when starting up the system for the first time, other items can be set or changed afterwards.

■ Start Up the Package

When starting up the Package for the first time after downloading, the following screen will be displayed:

>> Touch [OK] to display the main menu.

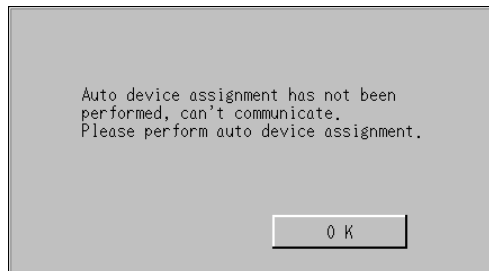

Note

After the Auto device assignment has been completed once, this screen does not appear when starting the Package. Instead, the message "Please wait..." will be displayed for about 15 seconds (10 seconds for the Direct-link version) after the power is turned on and then the MAIN MENU will appear.

- Main menu



To display the “DMC10 MAIN MENU”, press the lower left corner (the diagonally shaded areas in the above screen example) for at least 3 sec.

 **Note**

The user can select which items are displayed in the main menu. See ■ Display Configuration (p.5-16) for detailed information.

 **Handling Precautions**

[Exit] is not displayed when only a Package is downloaded and a User-application is not used.

See Chapter 8. COMBINED USE WITH USER APPLICATION for detailed information.

- Package configuration menu

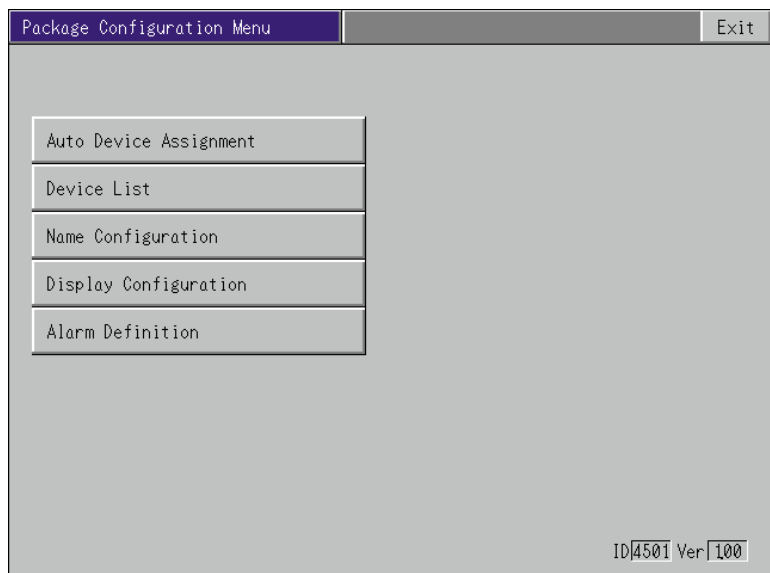

The following chart shows the configuration menu screen flow:

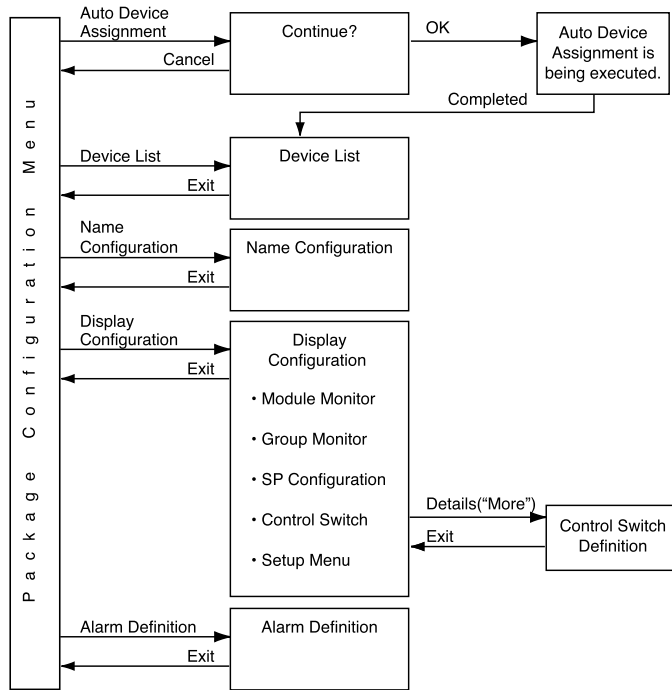

■ Auto Device Assignment

- (1) Check that all the devices that comprise the system (EST555Z, CMC10B and DMC10) are connected correctly and the communications configured.

Turn the power on.

- (2) Touch [Auto Assignment] in the “Package Configuration Menu”.

The following confirmation screen will be displayed:

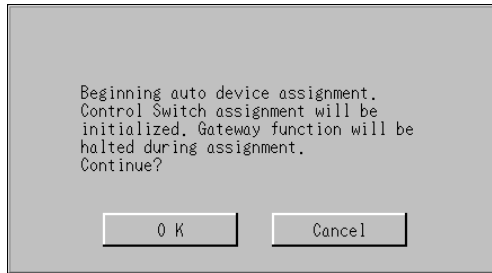

! Handling Precautions

The Control Switch Assignment will be initialized by executing this Auto Device Assignment.

The gateway function in action halts while the Auto Device Assignment is being executed. It resumes again when the Auto Device Assignment has been completed.

- (3) Touch [OK] to execute the Auto Device Assignment.

The following screen will be displayed to indicate the progress:

When completed, it will display the Device list screen automatically.

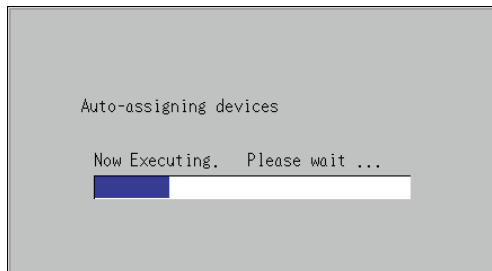

! Handling Precautions

When the system configuration is changed or when any of the following parameters are changed by the DMC10 PC loader after the Auto Device Assignment has been performed, Auto Device Assignment should be performed once again.

- Input type
- Decimal point position
- PV range low limit
- PV range high limit
- SP low limit
- SP high limit

If these parameters are changed by the Setup of the Package, it is not necessary to perform Auto Device Assignment again.

Conversely, if when position proportional control mode is used its control type is changed from 1 or 2, to 0, 3, or 4, then it is necessary to perform Auto Device Assignment again.

● **Device list (Direct-link version)**

In this screen, the assigned DMC10 units are indicated by blue lamps. Check that all the connected devices have been assigned.

If not, check if the wiring and the communication settings are correct and execute the Auto device assignment again.

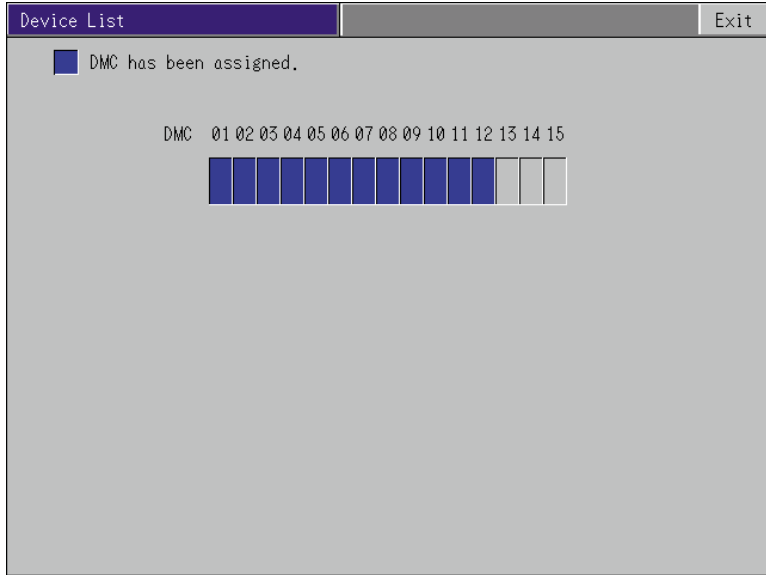

● **Device list (CMC-link version)**

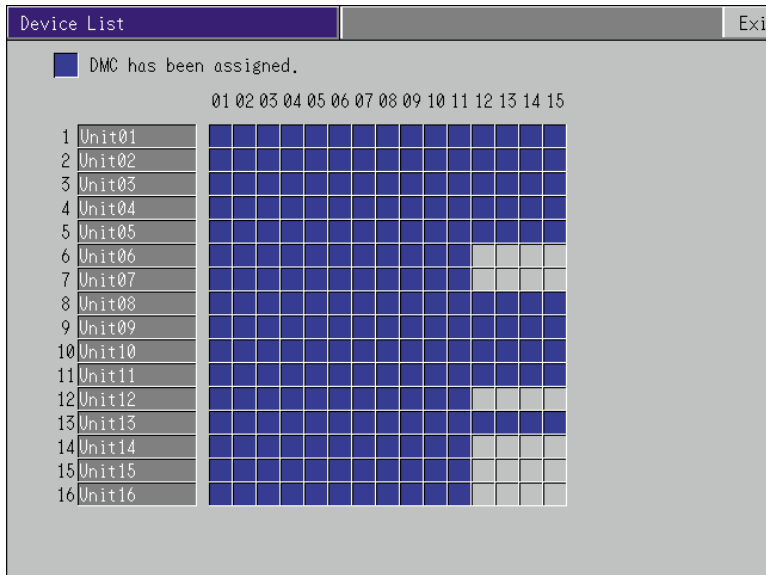

■ Display Configuration

The user can alter the display configuration for improved usability.
 Touch [Display Configuration Menu] in the Package Configuration Menu.

● Display configuration display

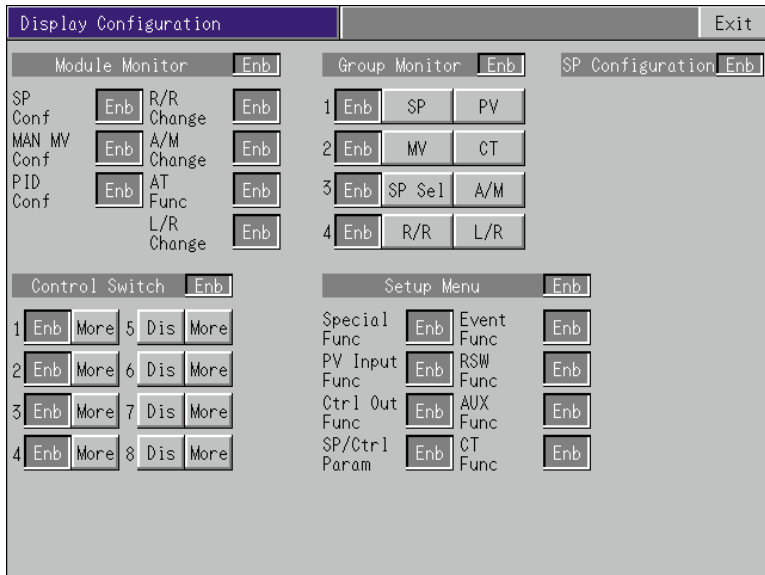

If the [Enb] / [Dis] switch of each item is set to [Dis], that item will not be displayed in the Main Menu.

Module Monitor

If [Dis] of the [Enb] / [Dis] switch is selected, that function will be disabled in the Module Monitor.

Group Monitor

- In the Group Monitor, four (4) groups can be defined as Disp1 to Disp4. In each group, the user can select two (2) types of data to monitor.
- If [Dis] of the [Enb] / [Dis] switch is selected, that item will not be displayed in the Group Monitor Menu.

- Touch an item to display the “Selection Menu” and select the data to monitor.

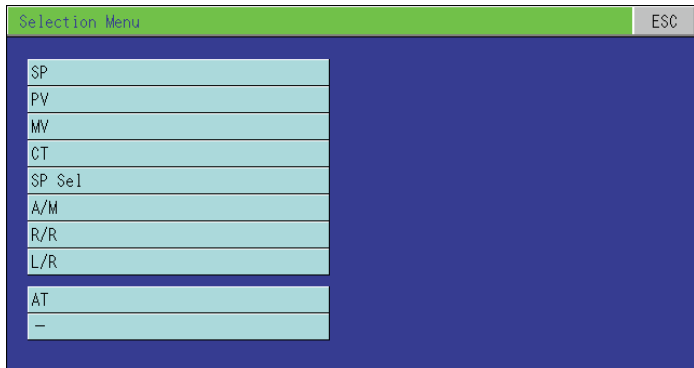

SP Configuration

No configuration is required.

Control Switch

- If [Dis] of the [Enb] / [Dis] switch is selected, that switch will not be displayed in the “Control Switch” screen.
- Touch [More] to go to the screens to define each switch.

Setup Menu

If [Dis] of the [Enb] / [Dis] switch is selected, that switch will not be displayed in the “Setup Menu” screen.

● **Control switch definition display**

The user can change the SP Group or the Mode by one operation by assigning such functions to the Control Switch.

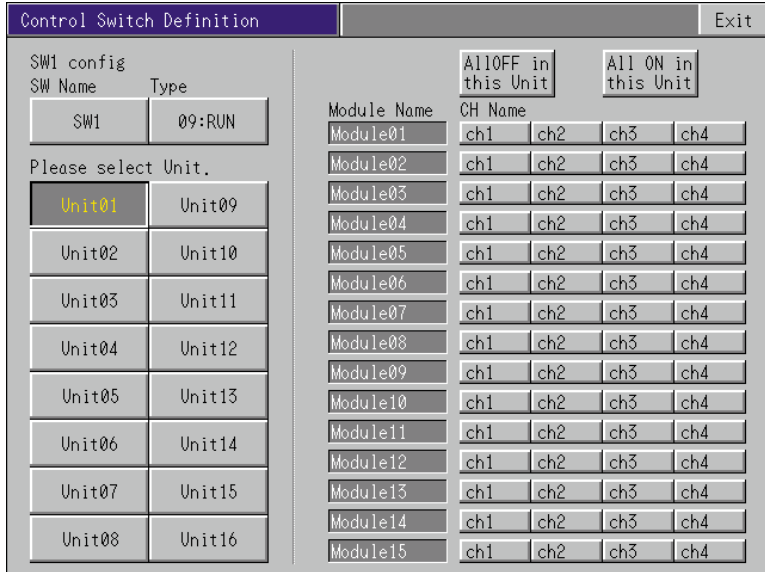

- Touch [SW Name] to popup the keyboard. Input the desired name for the switch. (Up to 12 letters.)
- Touch [Type] to display the “Selection Menu”. Select the function to be executed.
The selectable functions are: SP No.1 to 8, RUN, READY, AUTO, MANUAL, AT stop, AT start.
- For the Direct-link version, Unit selection is not performed.
- When selecting Unit in the CMC-link version, all the modules within the Unit are displayed.
- Select a location to write with Control Switch for each CH. For the CMC-link version, configure for all the required Units.
- [All OFF in this Unit] and [All ON in this Unit] switches change all the channels at once.

Handling Precautions

- In order to select SP No., “Multi SP” of the “Special Functions” of the target module should be [Enb].
With the 4CH model of the DMC10, if 5 or a larger number is selected as the SP No., a communications error will occur when the Control Switch is executed.
- If the DMC10 channels have operation conditions defined with the remote switch input(RSW) or event bus output(BUS), such channels cannot be changed by the Control switch.
For example, if the user attempts to assign “RUN/READY” of the control switch to a channel that has the condition “RUN when the remote switch input is on”, a communication error will occur.

■ Alarm Definition

When using a User application and Package together, the user can select whether the DMC10 Alarm Monitor functions during the operation of the User application with “Enb” or “Dis”.

If only the Package is used, this selection is meaningless.

The user can also add user-set events to the DMC10 Alarm Monitor.

In the 4 event relay outputs type DMC10 a total of 8 events can be defined including the 4 event bus outputs.

Even in a DMC10 without events, 8 events can be defined if “On” is selected in the Event Special section.

In this configuration, the user defines if each event is added as an alarm or not.

As the definition made in this Alarm Definition acts as the logical OR to the events of all the connected DMC10 units, this is used, for example, when the user wants to use one event channel as the high limit alarm through all the connected DMC10 units.



- If [Dis] of the [Enb] / [Dis] switch is selected, that event will not be added to the Alarm Monitor.
- Touch a [Name] to popup the keyboard. The user can input the event name. Such event names are displayed in the Alarm module detail screen.
- For detailed information of the DMC10 events, see the following manual. Distributed Multi-channel Controller DMC10 User's Manual Functional Description (Manual No. CP-UM-5143E)

! Handling Precautions

The alarm definition of the Package acts separately from the alarm monitor of the User application that was created by the AP editor.

Chapter 6. DMC10 SETUP AND MONITORING

■ DMC10 Setup

This section describes how to display and configure the necessary data before operating the DMC10.

The data is displayed and configured on a per module basis.

The following chart shows the screen flow:

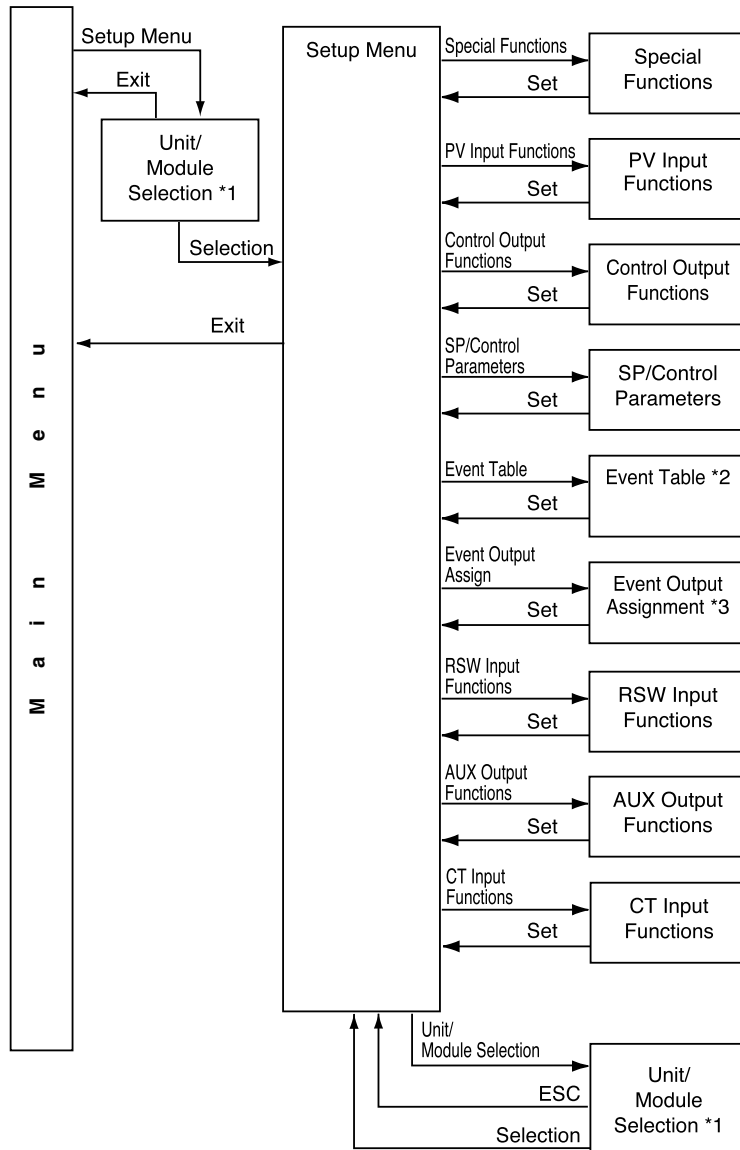

*1 : Unit Selection is not provided in the Direct-link version.

*2 : If the Event Special is not used, this name is displayed as Event Functions.

*3 : If the Event Special is not used, Event Out Assign is not available.

● Unit / Module selection

Touch [Setup Menu] in the MAIN MENU.

Select the target unit by [Unit/Module Selection] (CMC-link version only).





Select the target module by [Module Selection].

The “Setup Menu” screen of the target module is displayed.

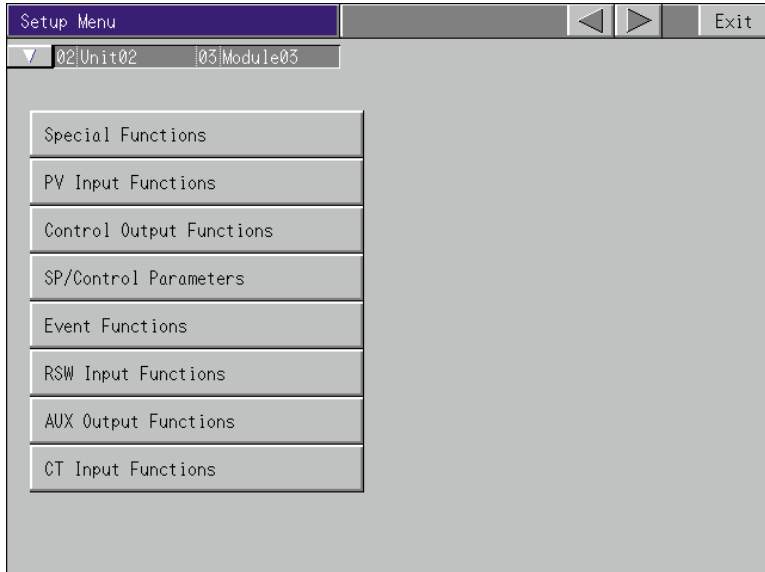

● Setup menu



- To select the unit and module again, touch  on the left of the Unit Name.
- Previous Module or next Module is displayed with .

● Special functions

The Special Functions of the DMC10 are configured with this screen.

Special Functions		ESC	Set
02 Unit02		03 Module03	
Multi SP	<input type="button" value="Enb"/>		
Event Special	<input type="button" value="Dis"/>		
RSW Special	<input type="button" value="Dis"/>		
Remote SP Input	<input type="button" value="Dis"/>		
Heat/Cool	<input type="button" value="Dis"/>		
PosnProp/ModCtrl	<input type="button" value="Dis"/>		

- If [Dis] of the [Enb] / [Dis] switch is selected, that function becomes inactive.
- Remote SP Input is displayed and configurable only in DMC10D (High function model).
- Heat/Cool is displayed only in DMC10D (High function model.)
- Position Proportional/Module Control will only be displayed for models which have this function.

! Handling Precautions

- Enb/Dis of Heat/Cool, and the Heat/Cool Output Assignment can not be configured by the Package.
They must be configured with the PC loader.
- Enb/Dis of Position Proportional/Module Control and the type of Position Proportional/Module Control can not be configured by the Package.
It must be configured with the PC loader.
- The [Enb] / [Dis] switch of the Remote SP Input is selectable only when the Heat/Cool is [Dis] and when the type of Position Proportional/Module Control is set as 0, 3, or 4.

● PV Input functions

The data for the PV input of each channel is displayed and configured with this screen.

PV Input Functions		ESC	Set	
02 Unit02		03 Module03		
	ch1	ch2	ch3	ch4
PV Input Type	43	43	43	43
Temp Unit				
Dec pt	0	0	0	0
PV Range Low	0	0	0	0
PV Range High	1000	1000	1000	1000
PV Bias	0	0	0	0
SP Range Low	0	0	0	0
SP Range High	1000	1000	1000	1000
SP Down Ramp	0	0	0	0
SP Up Ramp	0	0	0	0

! Handling Precautions

If the SP range is changed after the SP has been set by the ● SP/Control parameter (p.6-6), a Range Check will not be performed. Check the range by yourself and set the SP again if necessary.

- **Control output functions**

The data for the Control output of each channel is displayed and configured with this screen.

- When Position Proportional/Module Control is not available

Control Output Functions					ESC	Set	
02!Unit02		!03!Module03					
	ch1	ch2	ch3	ch4			
Control Method	2	2	2	2			
Control Action	0	0	0	0			
Time Prop Cycle	10	10	10	10			
Auto/Man Change Op	1	1	1	1			
Preset Manual Value	00	00	00	00			
Output at Ready	00	00	00	00			
Heat/Cool Deadzone							

- When Position Proportional/Module Control is available.

Control Output Functions					ESC	Set	
02!Unit02		!03!Module03					
	ch1	ch2					
Control Method	2	2					
Control Action	0	0					
Time Prop Cycle	10	10					
Auto/Man Change Op	1	1					
Preset Manual Value	00	00					
Output at Ready	00	00					
Heat/Cool Deadzone							
PosnProp/ModCtrl	Set	Set					

Touch [Set] switch of Position Proportional/Module Control to display “PosnProp/ModCtrl” screen.

● **Position proportional/module control**

The parameters necessary for Position Proportional/Module Control can be configured.

When feedback(FB) is being used, auto motor adjustment can be performed.

CH1 PosnProp/ModCtrl ESC Set

Dead zone 100 AutoAdjust ERR

Fully Closed InputValue 1400 Start Stop

Fully Open InputValue 6500 Open Close

Open/CloseTm 65 FBPres FB Alm

Motor Res. < 400ohm MFB 210

● **SP/Control parameters**

SP/Control Parameters ESC Set

02|Unit02 05|Module03

	ch1	ch2	ch3	ch4		ch1	ch2	ch3	ch4
SP1	100	100	100	100	P	100	100	100	100
SP2	120	120	120	120	I	120	120	120	120
SP3	200	200	200	200	D	30	30	30	30
SP4	140	140	140	140	RE				
					Diff				

When Multi SP of Special Functions is [Dis], the SP is set for only one display/setting.

● Event functions

Event Functions		ESC								Set
02Unit02		03Module03								
		EV1	EV2	EV3	EV4	BUS1	BUS2	BUS3	BUS4	
Type		3	3	3	3	4	4	4	4	
CH		1	2	3	4	1	2	3	4	
Event Value (main)		0	0	0	0	15	15	15	15	
Event value (sub)		1000	1000	1000	1000					
Hysteresis		5	5	5	5	5	5	5	5	
Polarity		0	0	0	0	0	0	0	0	
Stand-by		0	0	0	0	0	0	0	0	
Delay		Set	Set	Set	Set	Set	Set	Set	Set	

- When Event Special of Special Functions is configured to [Enb], the item names are displayed as TBL1 to TBL8 instead of EV1 to EV4 and BUS1 to BUS4.
- Touch [Set] switch of Delay to display the following “Event Delay” configuration screen:

Event Delay		ESC	Set
ON Delay /Hours	<input type="text" value="0"/>	OFF Delay /Hours	<input type="text" value="0"/>
ON Delay /Minutes	<input type="text" value="0"/>	OFF Delay /Minutes	<input type="text" value="0"/>
ON Delay /Seconds	<input type="text" value="10"/>	OFF Delay /Seconds	<input type="text" value="0"/>

● Event output assignment

Event Output Assign		ESC		Set				
02 Unit02		05 Module03						
	EV1	EV2	EV3	EV4	BUS1	BUS2	BUS3	BUS4
Output Assign1	0001	0002	0004	0008	0010	0020	0040	0080
Output Assign2	0000	0000	0000	0000	0000	0000	0000	0000
Output Assign3	0000	0000	0000	0000	0000	0000	0000	0000
Logic	0	0	0	0	0	0	0	0
Latch	0	0	0	0	0	0	0	0
Polarity	0	0	0	0	0	0	0	0
	OUT1	OUT2	OUT3	OUT4				
Output Assign1	1000	2000	4000	8000				
Output Assign2	0000	0000	0000	0000				
Output Assign3	0000	0000	0000	0000				
Logic	0	0	0	0				
Latch	0	0	0	0				
Polarity	0	0	0	0				

- When Event Special of Special Functions is configured to [Dis], this screen will not be displayed.
- Touch Output Assign 1 to 3 to popup display the following “Bit Input” screen of Event Output:

Bit Input										Exit
Output Assign1				Output Assign2				Output Assign3		
EV TBL1	EV TBL5	RSW1	OUT1	RSW TBL1	RSW TBL5	RSW BUS1	COM D11	COM D15	COM D19	
EV TBL2	EV TBL6	RSW2	OUT2	RSW TBL2	RSW TBL6	RSW BUS2	COM D12	COM D16	COM D110	
EV TBL3	EV TBL7	RSW3	OUT3	RSW TBL3	RSW TBL7	RSW BUS3	COM D13	COM D17	COM D111	
EV TBL4	EV TBL8	RSW4	OUT4	RSW TBL4	RSW TBL8	RSW BUS4	COM D14	COM D18	COM D112	

● RSW input functions

- This is the screen when RSW Special is set as [Dis].

RSW Input Functions		ESC		Set					
02 Unit02		03 Module03							
		RSW1	RSW2	RSW3	RSW4	BUS1	BUS2	BUS3	BUS4
Type		4	4	4	4	5	5	5	5
CH		1	2	3	4	1	2	3	4
Polarity		0	0	0	0	0	0	0	0

- This is the screen when RSW Special is set as [Enb].

RSW Input Functions		ESC		Set					
02 Unit02		03 Module03							
		TBL1	TBL2	TBL3	TBL4	TBL5	TBL6	TBL7	TBL8
Type		4	4	4	4	5	5	5	5
CH		1	2	3	4	1	2	3	4
Polarity		0	0	0	0	0	0	0	0
Logic		0	0	0	0	0	0	0	0
Input Assign1		0001	0002	0004	0008	0010	0020	0040	0080
Input Assign2		0000	0000	0000	0000	0000	0000	0000	0000
Input Assign3		0000	0000	0000	0000	0000	0000	0000	0000

- Touch Input Assign 1 to 3 to popup display the following “Bit Input” screen of RSW Input:

Bit Input												Exit
Input Assign1				Input Assign2				Input Assign3				
RSW1	RSW BUS1	EV TBL1	EV TBL5	EV1	COM DI1	COM DI5	COM DI9					
RSW2	RSW BUS2	EV TBL2	EV TBL6	EV2	COM DI2	COM DI6	COM DI10					
RSW3	RSW BUS3	EV TBL3	EV TBL7	EV3	COM DI3	COM DI7	COM DI11					
RSW4	RSW BUS4	EV TBL4	EV TBL8	EV4	COM DI4	COM DI8	COM DI12					

● AUX output functions

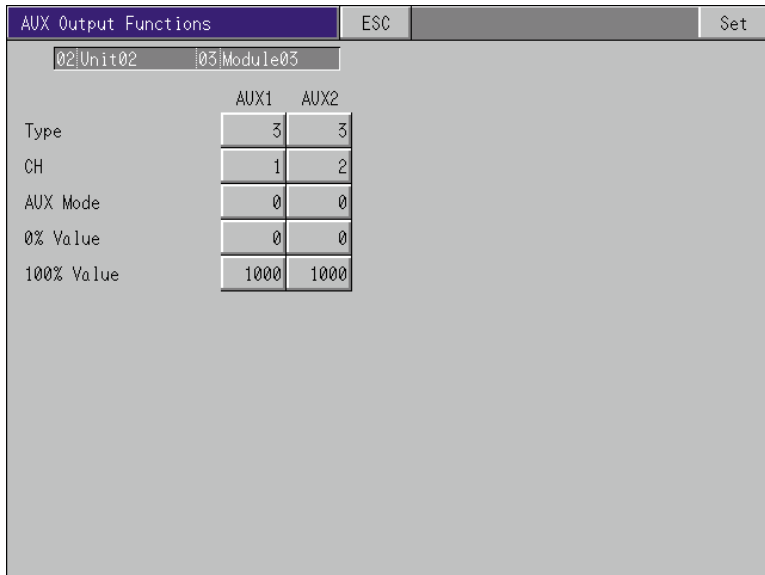

This screen is not displayed for DMC10 units without an AUX Output.

● CT(current) input functions

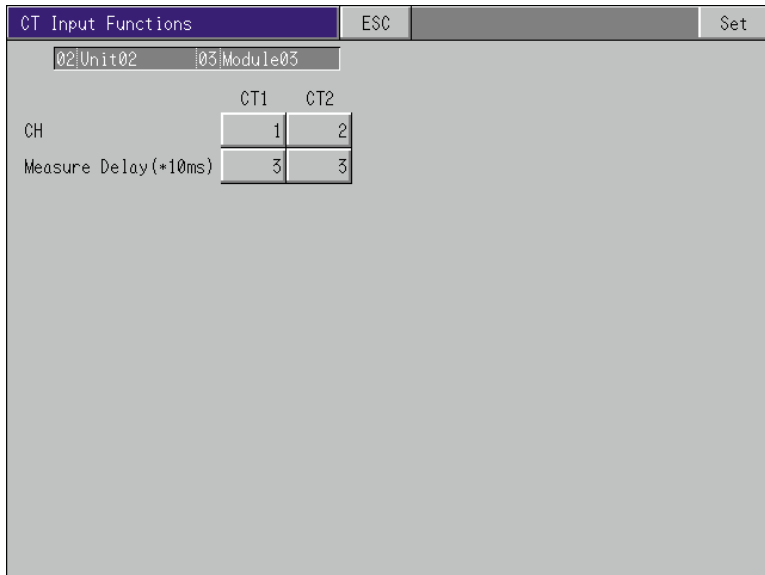

This screen is not displayed for DMC10 units without a Current Transformer input functions.

■ DMC10 Monitor

This section describes DMC10s Monitor function.

The following chart shows the screen flow of the monitoring functions:

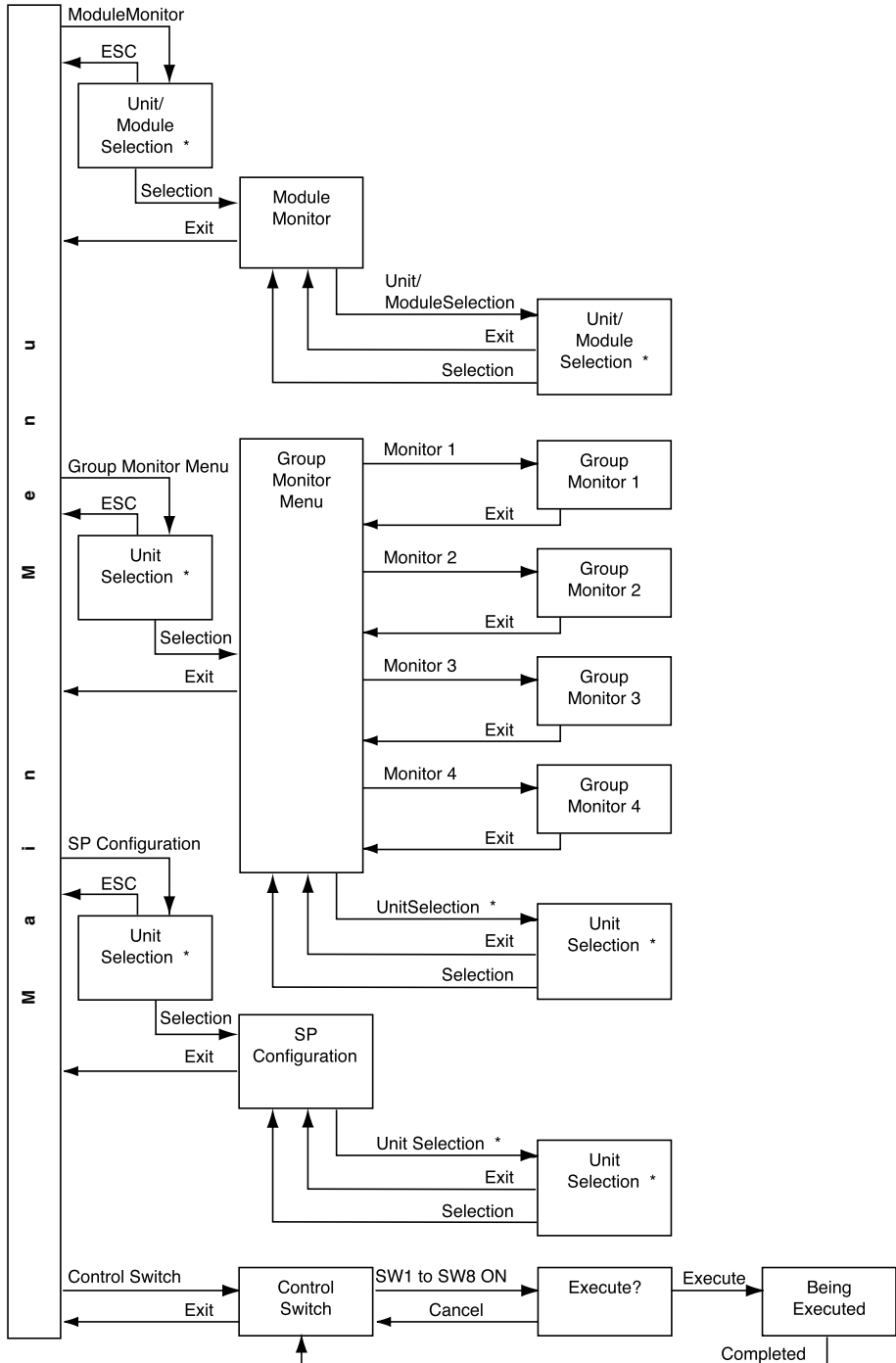

* Unit Selection is not provided in the Direct-link version.

● **Module monitor**

DMC10 can be monitored per module.

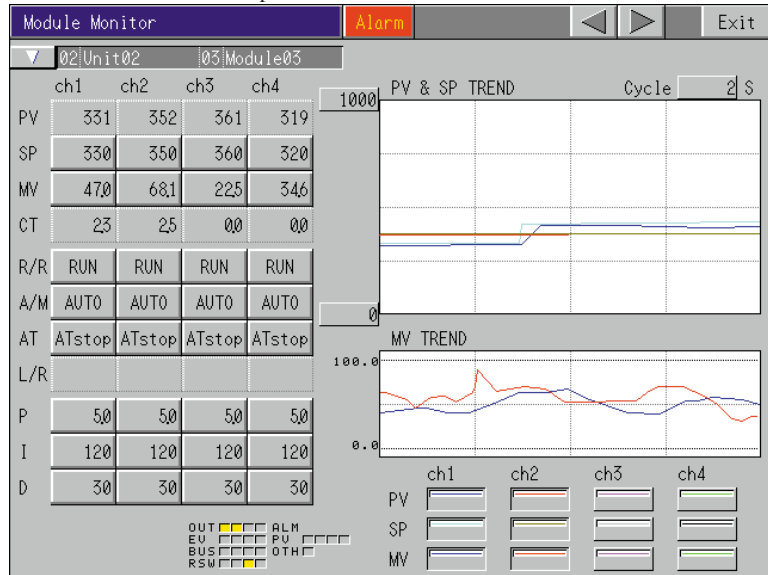

- Touch SP of each channel. The numeric keypad pops up. Input the desired SP value.
- In MANUAL mode, the numeric keypad pops up by touching the MV of each channel. Input the desired MV value.
- Touch R/R(RUN/READY), A/M(AUTO/MANUAL), AT(Start/Stop) and L/R(LOCAL/REMOTE) of each CH to change the mode.
- Touch PID values of each CH. A numeric key-pad pops up to enter a desired value.
- Touch the range value in the trend graph. A numeric key-pad pops up to change the numeric value. The change can be made within -2000 to +10000 range. The initial value and decimal point are the same as CH1 input range.
- Touch the value of Cycle in the trend graph. A numeric key-pad pops up to change the Cycle value. Configurable range is 1 to 10 seconds (initial value is 2 seconds).
- Touch each switch of PV, SP and MV to change the display/non-display of graph.
- Previous Module or next Module is displayed with ◀▶.

! Handling Precautions

- Switches that have been set as “Dis” in the Package configuration will not respond.
- Mode change may not be possible depending on the status of the DMC10.
- Trend data is cleared after exiting out of the Module Monitor.
- Trend data is cleared when the cycle is changed.
- To save the Trend data for a long time or to display only the desired channels, use Trend Smart Objects in the User application.

The lamps indicate the following conditions:

Lamp	ON when
OUT	Output terminal of the CH is ON
EV	EVENT terminal is ON
BUS	BUS output is ON, This lamp indicates the event bus output status of each module, instead of the OR status of the BUS of the connected modules.
RSW	Remote switch input is ON
ALM (PV)	PV input of the CH is in error
ALM (OTH)	Other errors have occurred

● Manual motor operation

When Position Proportional/Module Control is being used without feedback (control type 3 or 4), the motor can be operated manually.

In MANUAL operation, touch [MAN] switch at the bottom of channel to display the following screen:

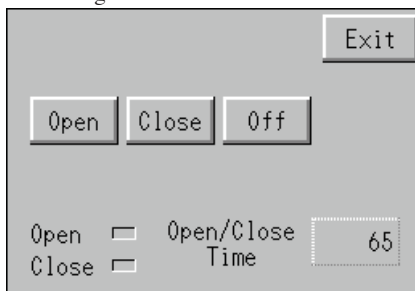

After pressing [Open] or [Close] once, that state will continue until [Off] is pressed. Press [Off] once the motor comes to a halt.

● Group monitor menu

The Menu that has been registered in the Package Configuration will be displayed.



● Group monitor 1 to 4

Touch an item in the Group Monitor Menu and select a unit
 [Unit Selection](CMC-link version only) to go to the “Group Monitor” screen.
 Here, all CH data within the selected Unit are displayed.

Group Monitor												Alarm	▲	▼	◀	▶	Exit
02 Unit02																	
01 Module01				02 Module02				03 Module03									
ch1	ch2	ch3	ch4	ch1	ch2	ch3	ch4	ch1	ch2	ch3	ch4						
SP	200	200	200	200	200	200	200	200	200	200	200	200					
PV	199	200	201	200	200	200	201	200	200	200	198	200					
04 Module04				05 Module05				06 Module06									
ch1	ch2	ch3	ch4	ch1	ch2	ch3	ch4	ch1	ch2	ch3	ch4						
SP	200	200	200	200	200	200	200	200	200	200	200	200					
PV	199	200	201	200	200	200	201	200	200	200	198	200					
07 Module07				08 Module08				09 Module09									
ch1	ch2	ch3	ch4	ch1	ch2	ch3	ch4	ch1	ch2	ch3	ch4						
SP	200	200	200	200	200	200	200	200	200	200	200	200					
PV	199	200	201	200	200	200	201	200	200	200	198	200					
10 Module10				11 Module11				12 Module12									
ch1	ch2	ch3	ch4	ch1	ch2	ch3	ch4	ch1	ch2	ch3	ch4						
SP	200	200	200	200	200	200	200	200	200	200	200	200					
PV	199	200	201	200	200	200	201	200	200	200	198	200					
13 Module13				14 Module14				15 Module15									
ch1	ch2	ch3	ch4	ch1	ch2	ch3	ch4	ch1	ch2	ch3	ch4						
SP	200	200	200	200	200	200	200	200	200	200	200	200					
PV	199	200	201	200	200	200	201	200	200	200	198	200					

- Previous item or next item is displayed with ▲▼.
- Previous Unit or next Unit is displayed with ◀▶.

● SP configuration

SP values of all CHs within the selected Unit can be displayed/changed.

SP Configuration												Alarm	◀	▶	Exit	
▼ 02 Unit02																
01 Module01				01 Module02				01 Module03								
ch1	ch2	ch3	ch4	ch1	ch2	ch3	ch4	ch1	ch2	ch3	ch4					
	200	200	200	200	200	200	200	200	200	200	200	200				
01 Module04				01 Module05				01 Module06								
ch1	ch2	ch3	ch4	ch1	ch2	ch3	ch4	ch1	ch2	ch3	ch4					
	200	200	200	200	200	200	200	200	200	200	200	200				
01 Module07				01 Module08				01 Module09								
ch1	ch2	ch3	ch4	ch1	ch2	ch3	ch4	ch1	ch2	ch3	ch4					
	200	200	200	200	200	200	200	200	200	200	200	200				
01 Module10				01 Module11				01 Module12								
ch1	ch2	ch3	ch4	ch1	ch2	ch3	ch4	ch1	ch2	ch3	ch4					
	200	200	200	200	200	200	200	200	200	200	200	200				
01 Module13				01 Module14				01 Module15								
ch1	ch2	ch3	ch4	ch1	ch2	ch3	ch4	ch1	ch2	ch3	ch4					
	200	200	200	200	200	200	200	200	200	200	200	200				

- Touch SP value of each CH. A numeric key-pad pops up to enter SP value.
- Touch ▼ on the left of Unit Name to make Unit selection. (Only CMC-link version)
- Previous Unit or next Unit can be displayed with ◀▶.

● **Control switch**

Control Switches that have been defined in the Package Configuration are displayed.

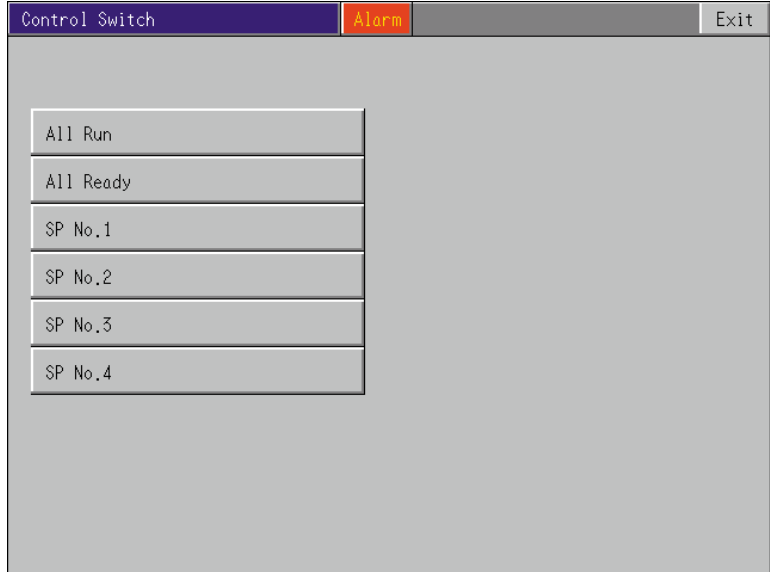

Touch a switch to display its Confirmation screen. Touch [OK] to execute the Control Switch.

■ **DMC10 Alarm Monitor**

The alarms of the DMC10 can be checked with the [Alarm] lamp in the screens of “DMC10 MAIN MENU”, “Module Monitor”, “Group Monitor”, and “Control Switch”.

Touch [Alarm] switch to go to the “Alarm Monitor”.

The following chart shows the screen flow of the “Alarm Monitor” :

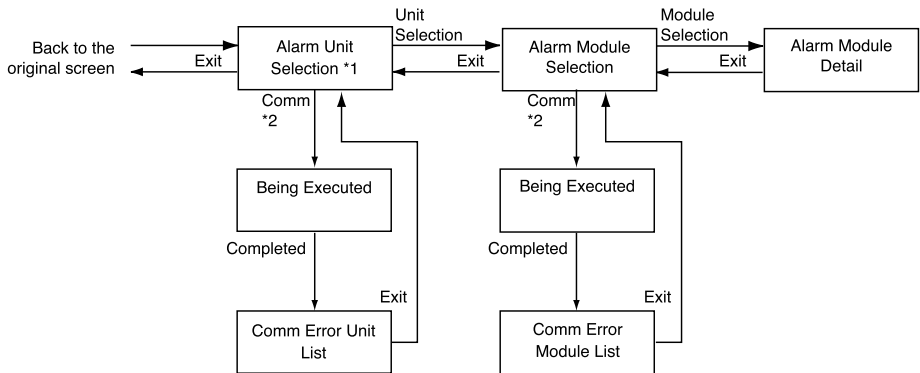

*1 : In the Direct-link version, it goes directly to the “Alarm Module List” by touching [Alarm].

*2 : Only at occurrence of communication error.

● Alarm unit selection (CMC-link version only)



- The modules that have errors are indicated with red lamps.
- Select Unit to go to “Module Selection” screen.
- [Comm] lamp lights when an error occurs in the communications with Unit (CMC10B). Touch [Comm] to go to the “Comm Error Unit List” screen. [Comm] is not displayed when communication is normal.

● Alarm module selection



- The modules that have errors are indicated with red lamps. Touch a module to go to its “Alarm Module Detail”.
- [Comm] lamp lights in red when communication error occurs. Touch [Comm] to go to the “Comm Error Module List”.

● Alarm module detail

The alarm details of each module are displayed.

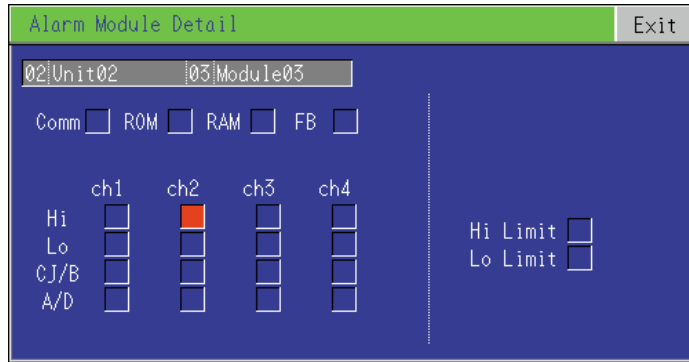

- The items that have an error are indicated with red lamps.
- On the right of the screen, the events that have been defined in the “Alarm Definition” of the “Package Configuration Menu” are displayed.

● Communication error unit list (CMC-link version only)

Unit list is displayed.

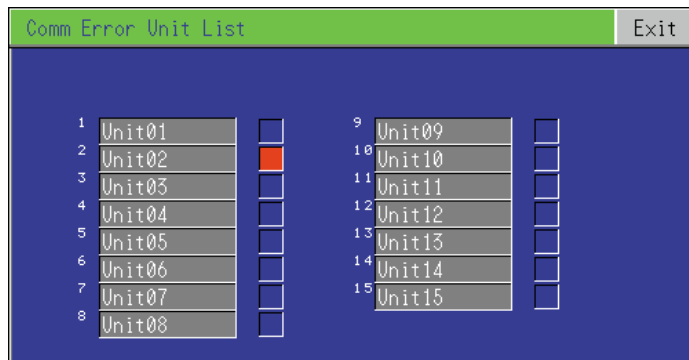

The units that have errors are indicated with red lamps.

● Communication error module list

List of modules within the Unit in question is displayed.

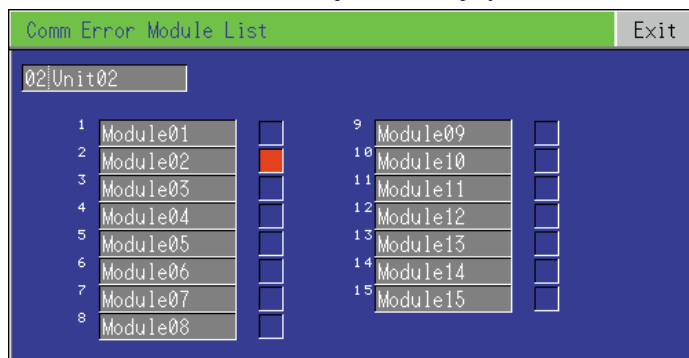

The modules that have errors are indicated with red lamps.

Chapter 7. USAGE EXAMPLES - GATEWAY AND CONTROL SWITCH

This chapter describes examples using the high-level functions of EST555Z/CMC10B/DMC10.

■ PLC Data Exchange with the EST555Z Gateway Function

The EST555Z Gateway function is used when the EST555Z is connected with a PLC. With this function, the user can read DMC10 data such as PV and Events to the PLC and write settings such as SP from the PLC to the DMC10.

● In Direct-link :

Function details are defined by [Configuration Information] - [Gateway] of the EST555Z AP Editor.

To read the DMC10 data to PLC :

DMC10 communication address and data address are specified in Source device.

PLC communication address and register address are specified in Destination device.

To write the data from PLC to DMC10:reverse the above.

PLC addresses are specified in Source device.

DMC10 addresses are specified in Destination device.

For detailed information on the Gateway function, see the following manual: SMART TERMINAL EST-Z Series User's Manual Application Preparation (Manual No.CP-SP-1088E)

! Handling Precautions

- EST555Z operation may slow down if the Gateway function is run often. In such a case, reduce the Gateway running frequency.
- To use the Gateway function, the user needs to create a User application and download it to the EST555Z together with the Package.

● In CMC-link :

The CMC10B which is assigned by Package performs cyclical reads of the basic data of connected DMC10 units. The EST555Z can read out the data in the read data area of the CMC10B. For the SP and communication DI (COM1 to COM 4) of each DMC10, the write area is reserved in the CMC10B. When data is transmitted from PLC to this area in one single operation, the CMC10B then writes that data to each DMC10.

To read and write to the CMC10B data area, use the EST555Z Gateway function.

The Gateway function is defined by [Configuration Information] → [Gateway] of the EST555Z AP Editor.

To read the DMC10 data to PLC :

CMC10B communication address and read data area are specified in Source device.

PLC communication address and register address are specified in Destination device.

To write the data from PLC to DMC10:reverse to the above.

PLC addresses are specified in Source device.

CMC10B address and write data area are specified in Destination device.

For detailed information on the Gateway function, see the following manual: SMART TERMINAL EST-Z Series User's Manual Application Preparation (Manual No.CP-SP-1088E)

The read and write data area of CMC10B are listed in the following tables:

• **CMC10B read data area (1001W to 1420W)**

DMC Communication address	1	2	3	4	5	6	7	8
Alarm	1001	1029	1057	1085	1113	1141	1169	1197
Reserved	1002	1030	1058	1086	1114	1142	1170	1198
Reserved	1003	1031	1059	1087	1115	1143	1171	1199
Control status 1	1004	1032	1060	1088	1116	1144	1172	1200
Control status 2	1005	1033	1061	1089	1117	1145	1173	1201
RSW internal calculation result	1006	1034	1062	1090	1118	1146	1174	1202
RSW Input state	1007	1035	1063	1091	1119	1147	1175	1203
Event output/Control output state	1008	1036	1064	1092	1120	1148	1176	1204
PV 1	1009	1037	1065	1093	1121	1149	1177	1205
PV 2	1010	1038	1066	1094	1122	1150	1178	1206
PV 3	1011	1039	1067	1095	1123	1151	1179	1207
PV 4	1012	1040	1068	1096	1124	1152	1180	1208
Current SP 1	1013	1041	1069	1097	1125	1153	1181	1209
Current SP 2	1014	1042	1070	1098	1126	1154	1182	1210
Current SP 3	1015	1043	1071	1099	1127	1155	1183	1211
Current SP 4	1016	1044	1072	1100	1128	1156	1184	1212
Current SP No.1	1017	1045	1073	1101	1129	1157	1185	1213
Current SP No.2	1018	1046	1074	1102	1130	1158	1186	1214
Current SP No.3	1019	1047	1075	1103	1131	1159	1187	1215
Current SP No.4	1020	1048	1076	1104	1132	1160	1188	1216
MV 1	1021	1049	1077	1105	1133	1161	1189	1217
MV 2	1022	1050	1078	1106	1134	1162	1190	1218
MV 3	1023	1051	1079	1107	1135	1163	1191	1219
MV 4	1024	1052	1080	1108	1136	1164	1192	1220
CT 1	1025	1053	1081	1109	1137	1165	1193	1221
CT 2	1026	1054	1082	1110	1138	1166	1194	1222
CT 3	1027	1055	1083	1111	1139	1167	1195	1223
CT 4	1028	1056	1084	1112	1140	1168	1196	1224

DMC Communication address	9	10	11	12	13	14	15
Alarm	1225	1253	1281	1309	1337	1365	1393
Reserved	1226	1254	1282	1310	1338	1366	1394
Reserved	1227	1255	1283	1311	1339	1367	1395
Control status 1	1228	1256	1284	1312	1340	1368	1396
Control status 2	1229	1257	1285	1313	1341	1369	1397
RSW internal calculation result	1230	1258	1286	1314	1342	1370	1398
RSW Input state	1231	1259	1287	1315	1343	1371	1399
Event output/Control output state	1232	1260	1288	1316	1344	1372	1400
PV 1	1233	1261	1289	1317	1345	1373	1401
PV 2	1234	1262	1290	1318	1346	1374	1402
PV 3	1235	1263	1291	1319	1347	1375	1403
PV 4	1236	1264	1292	1320	1348	1376	1404

DMC Communication address	9	10	11	12	13	14	15
Current SP 1	1237	1265	1293	1321	1349	1377	1405
Current SP 2	1238	1266	1294	1322	1350	1378	1406
Current SP 3	1239	1267	1295	1323	1351	1379	1407
Current SP 4	1240	1268	1296	1324	1352	1380	1408
Current SP No.1	1241	1269	1297	1325	1353	1381	1409
Current SP No. 2	1242	1270	1298	1326	1354	1382	1410
Current SP No.3	1243	1271	1299	1327	1355	1383	1411
Current SP No.4	1244	1272	1300	1328	1356	1384	1412
MV 1	1245	1273	1301	1329	1357	1385	1413
MV 2	1246	1274	1302	1330	1358	1386	1414
MV 3	1247	1275	1303	1331	1359	1387	1415
MV 4	1248	1276	1304	1332	1360	1388	1416
CT 1	1249	1277	1305	1333	1361	1389	1417
CT 2	1250	1278	1306	1334	1362	1390	1418
CT 3	1251	1279	1307	1335	1363	1391	1419
CT 4	1252	1280	1308	1336	1364	1392	1420

• Alarm

2 ¹⁵	2 ¹⁴	2 ¹³	2 ¹²	2 ¹¹	2 ¹⁰	2 ⁹	2 ⁸	2 ⁷	2 ⁶	2 ⁵	2 ⁴	2 ³	2 ²	2 ¹	2 ⁰	
16	15	14	13	12	11	10	9	8	7	6	5	4	3	2	1	
Bit	Item														Value	
1	Event 1 internal calculation result														0 : OFF 1 : ON	
2	Event 2 internal calculation result														0 : OFF 1 : ON	
3	Event 3 internal calculation result														0 : OFF 1 : ON	
4	Event 4 internal calculation result														0 : OFF 1 : ON	
5	Event 5 internal calculation result														0 : OFF 1 : ON	
6	Event 6 internal calculation result														0 : OFF 1 : ON	
7	Event 7 internal calculation result														0 : OFF 1 : ON	
8	Event 8 internal calculation result														0 : OFF 1 : ON	
9	PV error of channel 1														0 : OK 1 : Error	
10	PV error of channel 2														0 : OK 1 : Error	
11	PV error of channel 3														0 : OK 1 : Error	
12	PV error of channel 4														0 : OK 1 : Error	
13	Reserved														always 0	
14	Checksum error in RAM (Parameter area)														0 : OK 1 : Error	
15	Checksum error in RAM (Adjustment area)														0 : OK 1 : Error	
16	Checksum error in EEPROM														0 : OK 1 : Error	

• Control Status 1

	2 ¹⁵	2 ¹⁴	2 ¹³	2 ¹²	2 ¹¹	2 ¹⁰	2 ⁹	2 ⁸	2 ⁷	2 ⁶	2 ⁵	2 ⁴	2 ³	2 ²	2 ¹	2 ⁰
	16	15	14	13	12	11	10	9	8	7	6	5	4	3	2	1

Bit	Item	Value
1	PVCH1 AUTO/MANUAL mode	0 : AUTO 1 : MANUAL
2	PVCH1 RUN/READY mode	0 : RUN 1 : READY
3	PVCH1 RSP mode	0 : LOCAL 1 : REMOTE
4	PVCH1 AT mode (Auto tune)	0 : AT Stop 1 : AT Start
5	PVCH2 AUTO/MANUAL mode	0 : AUTO 1 : MANUAL
6	PVCH2 RUN/READY mode	0 : RUN 1 : READY
7	PVCH2 LOCAL/REMOTE mode	0 : LOCAL 1 : REMOTE
8	PVCH2 AT mode (Auto tune)	0 : AT Stop 1 : AT Start
9	PVCH3 AUTO/MANUAL mode	0 : AUTO 1 : MANUAL
10	PVCH3 RUN/READY mode	0 : RUN 1 : READY
11	Reserved	always 0
12	PVCH3 AT mode (Auto tune)	0 : AT Stop 1 : AT Start
13	PVCH4 AUTO/MANUAL mode	0 : AUTO 1 : MANUAL
14	PVCH4 RUN/READY mode	0 : RUN 1 : READY
15	Reserved	always 0
16	PVCH4 AT mode (Auto tune)	0 : AT Stop 1 : AT Start

• Control Status 2

	2 ¹⁵	2 ¹⁴	2 ¹³	2 ¹²	2 ¹¹	2 ¹⁰	2 ⁹	2 ⁸	2 ⁷	2 ⁶	2 ⁵	2 ⁴	2 ³	2 ²	2 ¹	2 ⁰
	16	15	14	13	12	11	10	9	8	7	6	5	4	3	2	1

Bit	Item	Value
1	PVCH1 Self-tuning correction/ correction standby	0 : correction 1 : correction standby
2	Reserved	always 0
3	Reserved	always 0
4	Reserved	always 0
5	PVCH2 Self-tuning correction/ correction standby	0 : correction 1 : correction standby
6	Reserved	always 0
7	Reserved	always 0
8	Reserved	always 0
9	PVCH3 Self-tuning correction/ correction standby	0 : correction 1 : correction standby
10	Reserved	always 0
11	Reserved	always 0
12	Reserved	always 0
13	PVCH4 Self-tuning correction/ correction standby	0 : correction 1 : correction standby
14	Reserved	always 0
15	Reserved	always 0
16	Reserved	always 0

- RSW internal calculation result

	2^{15}	2^{14}	2^{13}	2^{12}	2^{11}	2^{10}	2^9	2^8	2^7	2^6	2^5	2^4	2^3	2^2	2^1	2^0
	16	15	14	13	12	11	10	9	8	7	6	5	4	3	2	1

Bit	Item	Value
1	RSW internal calculation result 1	
2	RSW internal calculation result 2	
3	RSW internal calculation result 3	
4	RSW internal calculation result 4	
5	RSW internal calculation result 5	
6	RSW internal calculation result 6	
7	RSW internal calculation result 7	
8	RSW internal calculation result 8	
9	Reserved	
10	Reserved	
11	Reserved	
12	Reserved	
13	Communication DI 1	
14	Communication DI 2	
15	Communication DI 3	
16	Communication DI 4	

- RSW Input mode

Contents are same as the DMC10 1045W. For detail information, refer to the Distributed Multi-channel Controller DMC10 User's Manual Functional Description (Manual No. CP-UM-5143E).

- Event output/Control output mode

Contents are same as the DMC10 1046W. For detail information, refer to the Distributed Multi-channel Controller DMC10 User's Manual Functional Description (Manual No. CP-UM-5143E).

- **CMC10B write data area (1676W to 1795W)**

DMC10 Comm. address	Current SP DMC10 Data 5008-5011	Comm.DI1 to 4 DMC10 Data 5101-5104
1	1676-1679	1736-1739
2	1680-1683	1740-1743
3	1684-1687	1744-1747
4	1688-1691	1748-1751
5	1692-1695	1752-1755
6	1696-1699	1756-1759
7	1700-1703	1760-1763
8	1704-1707	1764-1767
9	1708-1711	1768-1771
10	1712-1715	1772-1775
11	1716-1719	1776-1779
12	1720-1723	1780-1783
13	1724-1727	1784-1787
14	1728-1731	1788-1791
15	1732-1735	1792-1795

! Handling Precautions

- Data written to the above area will be written to the DMC10 EEPROM.
- Writing to Comm. DI1 to 4 is not possible when the EST Info of the DMC10 is less than “4”.
- Errors occurring between CMC10B and DMC10 cannot be detected by the Gateway function, that writes the data from PLC to DMC10 through CMC10B. The errors that can be detected by the Gateway function are the errors occurring between the PLC, EST555Z and CMC10B.
To check if the data has been written to the DMC10 correctly, use other measures such as comparing the data written from PLC and the data read after a certain time.
- EST555Z operation may slow down if the Gateway function is run often. In such a case, reduce the Gateway running frequency.

■ Control DMC10 using the Control Switch

The following example shows how to change RUN/READY of all the connected DMC10 using the Control switch:

The Package should be configured as follows.

- (1) Touch [Display Configuration Menu] of the [Package Configuration Menu], then [Control Switch]. Set the SW1 and SW2 as Enb.

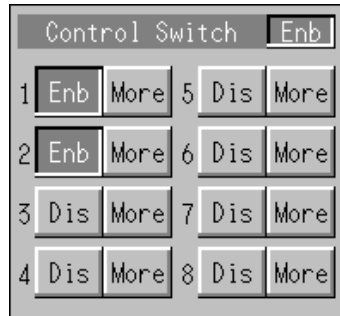

- (2) Touch [More] of SW1 to go to its “Control Switch Definition” screen. Set the SW Name and Type as in the following example:

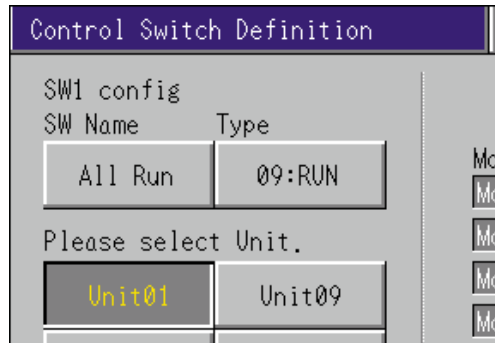

- (3) To operate all the DMC10 in one operation, press [All ON] for each unit. If separate operation to some CH is necessary, set OFF/ON of those CH separately.
- (4) Touch [More] of SW2 in the screen of (1) to go to its “Control Switch Definition” screen. Set the SW Name and Type as in the following example:

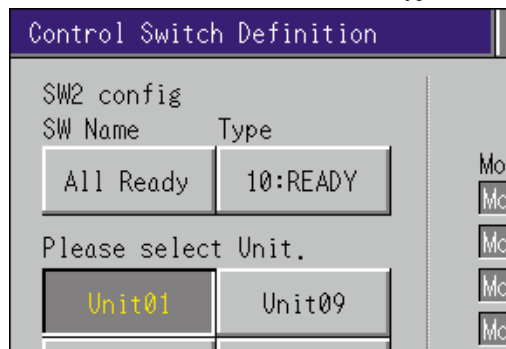

- (5) Configure the same as in (3)

Now configuration has been completed.

To check the operation, touch [Control Switch] in the MAIN MENU.
The following screen should appear:

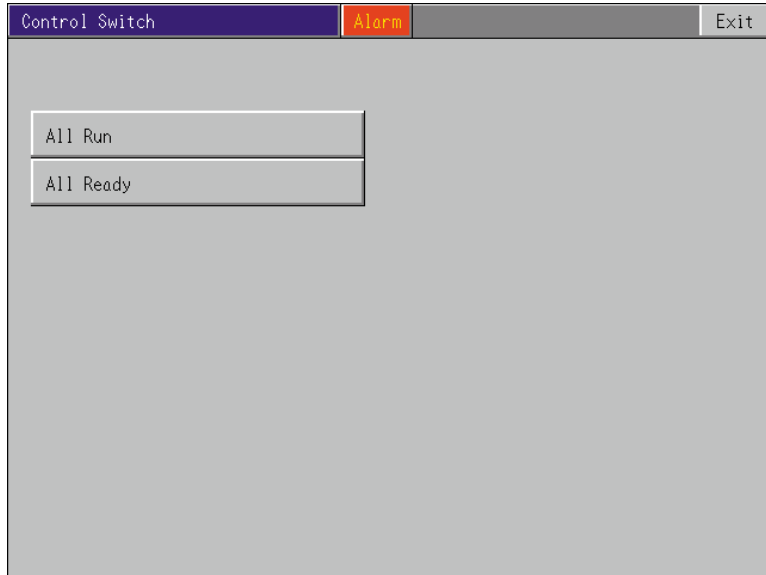

- [All Run] To RUN all the DMC10 at once.
- [All Ready] To make all the DMC10 READY at once.

Chapter 8. COMBINED USE WITH USER APPLICATION

In addition to the functions of the Package, users can create their own application screens.

For information on how to create a User application, see the following manual:

SMART TERMINAL EST-Z Series User's Manual Application Preparation (Manual No.CP-SP-1088E)

When turning the power on after downloading both a User application and a Package, screen 1(panel 1) of the User application will start.

To go to the Package screen, attach a "Panel Change" object on any desired screen of the User application.

Select [Dedicated Package Change] as the parameter type, when configuring the object.

Touch this object to go to the main menu of the Package.

To go back to the User application from the Package, touch [Exit] on the "DMC10 MAIN MENU" screen of the Package.

! Handling Precautions

- When calling up the Package, the screen size should be the whole screen size (640x480 dot).
- Do not call up the Package when more than one screen is already opened. Since when returning from the Package, only one screen can be started again.
- If starting the [Dedicated Package Change] with External Execution, do not attach it to the back ground panel. Since the user panel will not be able to be started when returning from the Package.

The background panel of the User application is running even while the Package is being operated.

The user can select whether, or not, to let the Package monitor DMC10 alarms while the User application is being operated as follows: Go to [Alarm Definition] of the Package Configuration Menu.

Select [Enb] / [Dis] of the "Package Alarm with User apli".

Name	Control	Name
EV1 (TBL1)	Dis EV1	BUS1 (TBL5) Enb Hi Limit
EV2 (TBL2)	Dis EV2	BUS1 (TBL5) Enb Lo Limit
EV3 (TBL3)	Dis EV3	BUS1 (TBL5) Dis BUS3
EV4 (TBL4)	Dis EV4	BUS1 (TBL5) Dis BUS4

● Illustration of transition between Package and User application

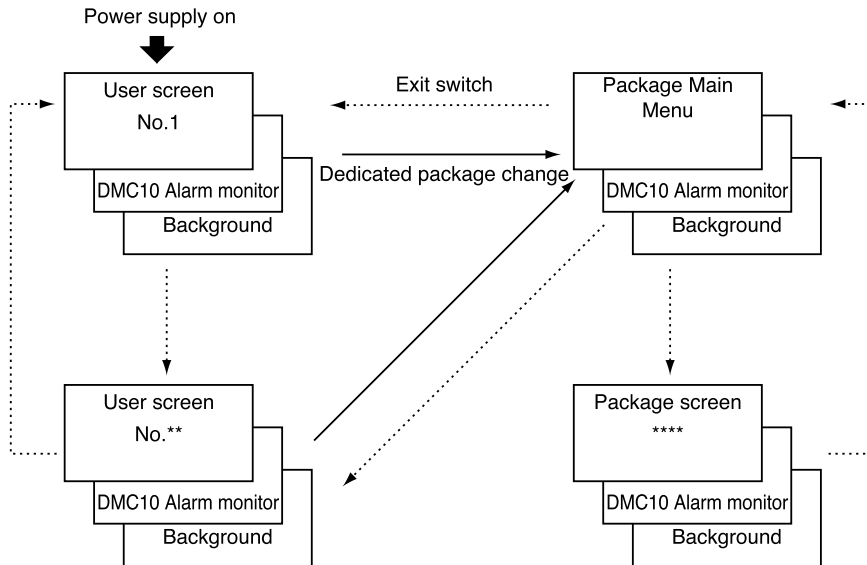

● Package status devices that can be checked from the User application

The operation status of the Package can be checked from the User application. The devices that can be checked are as follows:

Status device	Name	Description
TR800010.2	DMC10 Alarm Monitor	0 : Not monitoring 1 : Monitoring
TR800010.8	CMC Buffering Error (CMC link version only)	0 : No error 1 : Error
TR800011.0	DMC10 Alarms	0 : No Alarm 1 : Alarm Valid only when the Alarm monitor is active during the User application's operation.

Chapter 9. TROUBLESHOOTING

Problems can be divided into the following categories.

- Package related
- DMC10 related

■ Package Troubleshooting

● Error message appears on the package display

Error messages that appear on the package display, their causes and appropriate counter measures are as follows:

Error Message	Cause	Counter measure
Auto device assignment has not been performed, can't commence communications. Please perform auto device assignment.	Device configuration is unknown, since auto device assignment has not been performed.	Perform [Auto Device Assignment] of the [Package Configuration Menu].
No DMC10 devices could be assigned. Please verify wiring and configuration, then retry.	No valid DMC10 was detected through auto device assignment.	Check communication settings of each device. Check the wiring of the cables. Perform auto device assignment again.
DMC package does not support this module. Auto assignment can't be performed.	The version of the DMC10 is not supported by the Package.	Change the DMC10 unit for one with the version that is supported by the Package.
WRITE destination not specified. Please specify, then retry.	The write destination of the control switch has not been specified.	Setup the type and assignment with [Package Configuration Menu] → [Disp. Conf. Menu] → [Control Switch].
Error reading data from module.	<ul style="list-style-type: none"> • Data cannot be read because of DMC10 failure or communication error. • The target module is different from the module that was registered by the auto device assignment. 	<ul style="list-style-type: none"> • Check the wiring of the cables. • Perform Auto device assignment again, if the device configuration has been changed.
Error writing data to module.	<ul style="list-style-type: none"> • Data cannot be written because of DMC10 failure or communication error. • The target module is different from the module that was registered by the auto device assignment. • One of the following items of the target module was changed by the PC loader after auto device assignment: Input type, decimal point position, PV range lower limit, PV range upper limit, SP lower limit, SP upper limit 	<ul style="list-style-type: none"> • Check the wiring of the cables. • Perform Auto device assignment again, if the device configuration has been changed.
Start-up processing failed. Please reset the power to the modules, or perform device auto-assignment. (ONLY CMC-LINK TYPE)	<ul style="list-style-type: none"> • CMC Buffer configuration failed. 	<ul style="list-style-type: none"> • Check the wiring of the cables • Check if the power is supplied correctly to the CMC10B. Reboot EST555Z. • Perform Auto device assignment again, if the device configuration has been changed.

● **Flash Memory Troubleshooting**

For the Package, each data of the following operations is written into the blank flash-memory of the EST555Z:

- When Auto Device Assignment is executed.
- When Unit/Module Name configuration is performed.
- When Display Configuration is registered. (When returning from “Package Configuration Menu”.)
- When PV input data of the DMC10 is configured.

The memory is consumed little by little when this data is written. If the memory has becomes full, the following message will be displayed:

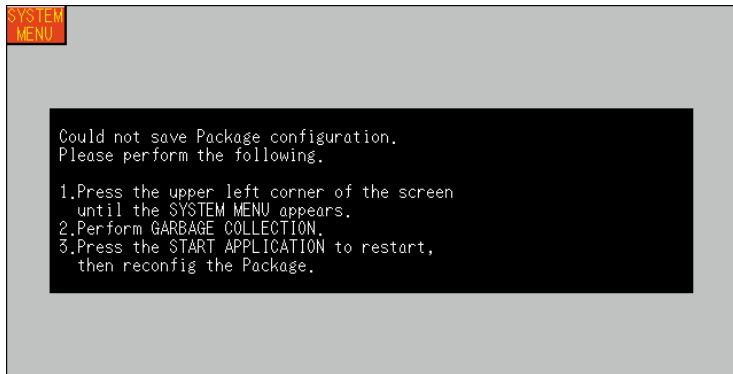

Execute [Garbage Collection] of the system screen in accordance with the indication of the screen. This operation can delete unnecessary data in the memory and optimize the memory.

● **Other troubleshooting**

Troubles	Cause	Counter measure
MODE or SP/MV that have been changed by Module monitor are not reflected to DMC10 screens.	Write cannot be accepted owing to the DMC10 operation status. e.g.: MANUAL change during ON/OFF control, RUN/READY is defined by RSW input.	Modify the settings to match the DMC10 operation status.
Error messages are displayed when executing Control switches.	<ul style="list-style-type: none"> • Write cannot be accepted owing to the DMC10 operation status. e.g.: MANUAL change during ON/OFF control, SP number change when the Multi SP group is not used, SP No. 5 to 8 in 4CH model. • Write destination of the Control switches has not been specified. 	Modify the settings to match the DMC10 operation status.

■ **DMC10 Troubleshooting**

When DMC10 alarms occur, use “Alarm List” screen or “Alarm Module Detail” screen to check where the alarms are occurring and the details of the alarms.

For information on the cause and counter measures for each alarm, see the following DMC10 manual:

Distributed Multi-channel Controller DMC10 User's Manual Functional Description (Manual No. CP-UM-5143E)

azbil

Specifications are subject to change without notice.

Yamatake Corporation
Advanced Automation Company

1-12-2 Kawana, Fujisawa
Kanagawa 251-8522 Japan

URL: <http://www.azbil.com>

Printed on recycled paper. (07)

Printed in Japan.
1st Edition: Issued in Dec. 2001(C)
2nd Edition: Issued in Mar. 2008(G)