

Service Guide Specification

1. Model Description

MODEL	L1750S-SNN L1950S-SNN	BRAND	LG	LEE H.J 05.01.06	KIM J.O 05.01.06
SUFFIX	ANUSQG	Product Name	FLATRON L1750S FLATRON L1950S	Part No.	3828TSL096P

2. Printing Specification

1. Trim Size (Format) : **215mm x 280 mm**

2. Printing Colors

- Cover : **LG COLORS**
- Inside : **Black**

3. Stock (Paper)

- Cover : **Snow White 150 g/m²**
- Inside : **Snow White 100 g/m²**

4. Printing Method :

5. Bindery : **Saddle stitch**

6. Language : **English**

7. Number of pages : **28 (Including blank 1 page)**

3. Special Instructions

(1) Origin Notification

- * LGEDI : Printed in Indonesia
- * LGEWA : Printed in U.K.
- * LGESP : Printed in Brazil
- * LGEMX : Printed in Mexico
- * LGENT : Printed in China
- * LGEIL : Printed in India

4. Changes

8					
7					
6					
5					
4					
3					
2					
1					
REV. NO.	MM/DD/YY	SIGNATURE	CHANGE NO.	CHANGE CONTENTS	

Pagination sheet

P/NO.3828TSL096P
Total pages : 28pages

Cover	Front cover Inside	English	English	English	English	English	English
	blank	2	3	4	
	English	English	English	English	English	Rear cover Inside	Rear Cover
	22	23	24	25	26	

<http://www.wjel.net>



Website:<http://biz.LGservice.com>
E-mail:<http://www.LGservice.com/techsup.html>

COLOR MONITOR SERVICE MANUAL

CHASSIS NO. : CL-82

MODEL: FLATRON L1750S (L1750S-SNN.AN**QF)

FLATRON L1950S (L1950S-SNN.AN**QF)

() **Same model for Service

CAUTION

BEFORE SERVICING THE UNIT,
READ THE **SAFETY PRECAUTIONS** IN THIS MANUAL.

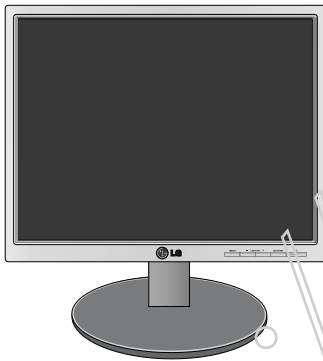

*To apply the **Genesis ZAN3SL Chip**.

<http://www.wjel.net>

PRECAUTION

WARNING FOR THE SAFETY-RELATED COMPONENT.

- There are some special components used in LCD monitor that are important for safety. **These parts are marked \triangle on the schematic diagram and the replacement parts list.** It is essential that these critical parts should be replaced with the manufacturer's specified parts to prevent electric shock, fire or other hazard.
- Do not modify original design without obtaining written permission from manufacturer or you will void the original parts and labor guarantee.

TAKE CARE DURING HANDLING THE LCD MODULE WITH BACKLIGHT UNIT.

- Must mount the module using mounting holes arranged in four corners.
- Do not press on the panel, edge of the frame strongly or electric shock as this will result in damage to the screen.
- Do not scratch or press on the panel with any sharp objects, such as pencil or pen as this may result in damage to the panel.
- Protect the module from the ESD as it may damage the electronic circuit (C-MOS).
- Make certain that treatment person's body are grounded through wrist band.
- Do not leave the module in high temperature and in areas of high humidity for a long time
- The module not be exposed to the direct sunlight.
- Avoid contact with water as it may a short circuit within the module.
- If the surface of panel become dirty, please wipe it off with a softmaterial. (Cleaning with a dirty or rough cloth may damage the panel.)

\triangle CAUTION

Please use only a plastic screwdriver to protect yourself from shock hazard during service operation.

\triangle WARNING

BE CAREFUL ELECTRIC SHOCK !

- If you want to replace with the new backlight (CCFL) or inverter circuit, must disconnect the AC adapter because high voltage appears at inverter circuit about 650Vrms.
- Handle with care wires or connectors of the inverter circuit. If the wires are pressed cause short and may burn or take fire.

Leakage Current Hot Check Circuit

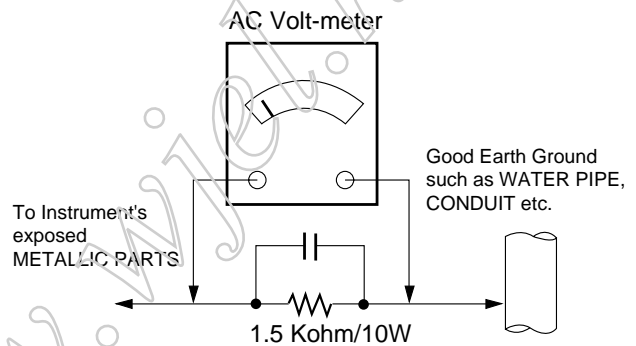

SERVICING PRECAUTIONS

CAUTION: Before servicing receivers covered by this service manual and its supplements and addenda, read and follow the **SAFETY PRECAUTIONS** on page 3 of this publication.

NOTE: If unforeseen circumstances create conflict between the following servicing precautions and any of the safety precautions on page 3 of this publication, always follow the safety precautions. Remember: Safety First.

General Servicing Precautions

1. Always unplug the receiver AC power cord from the AC power source before;
 - a. Removing or reinstalling any component, circuit board module or any other receiver assembly.
 - b. Disconnecting or reconnecting any receiver electrical plug or other electrical connection.
 - c. Connecting a test substitute in parallel with an electrolytic capacitor in the receiver.
CAUTION: A wrong part substitution or incorrect polarity installation of electrolytic capacitors may result in an explosion hazard.
 - d. Discharging the picture tube anode.
2. Test high voltage only by measuring it with an appropriate high voltage meter or other voltage measuring device (DVM, FETVOM, etc) equipped with a suitable high voltage probe.
Do not test high voltage by "drawing an arc".
3. Discharge the picture tube anode only by (a) first connecting one end of an insulated clip lead to the degaussing or kine aquadag grounding system shield at the point where the picture tube socket ground lead is connected, and then (b) touch the other end of the insulated clip lead to the picture tube anode button, using an insulating handle to avoid personal contact with high voltage.
4. Do not spray chemicals on or near this receiver or any of its assemblies.
5. Unless specified otherwise in this service manual, clean electrical contacts only by applying the following mixture to the contacts with a pipe cleaner, cotton-tipped stick or comparable non-abrasive applicator; 10% (by volume) Acetone and 90% (by volume) isopropyl alcohol (90%-99% strength)
CAUTION: This is a flammable mixture.
Unless specified otherwise in this service manual, lubrication of contacts is not required.
6. Do not defeat any plug/socket B+ voltage interlocks with which receivers covered by this service manual might be equipped.
7. Do not apply AC power to this instrument and/or any of its electrical assemblies unless all solid-state device heat sinks are correctly installed.
8. Always connect the test receiver ground lead to the receiver chassis ground before connecting the test receiver positive lead.
Always remove the test receiver ground lead last.

9. Use with this receiver only the test fixtures specified in this service manual.

CAUTION: Do not connect the test fixture ground strap to any heat sink in this receiver.

Electrostatically Sensitive (ES) Devices

Some semiconductor (solid-state) devices can be damaged easily by static electricity. Such components commonly are called *Electrostatically Sensitive (ES) Devices*. Examples of typical ES devices are integrated circuits and some field-effect transistors and semiconductor "chip" components. The following techniques should be used to help reduce the incidence of component damage caused by static by static electricity.

1. Immediately before handling any semiconductor component or semiconductor-equipped assembly, drain off any electrostatic charge on your body by touching a known earth ground. Alternatively, obtain and wear a commercially available discharging wrist strap device, which should be removed to prevent potential shock reasons prior to applying power to the unit under test.
2. After removing an electrical assembly equipped with ES devices, place the assembly on a conductive surface such as aluminum foil, to prevent electrostatic charge buildup or exposure of the assembly.
3. Use only a grounded-tip soldering iron to solder or unsolder ES devices.
4. Use only an anti-static type solder removal device. Some solder removal devices not classified as "anti-static" can generate electrical charges sufficient to damage ES devices.
5. Do not use freon-propelled chemicals. These can generate electrical charges sufficient to damage ES devices.
6. Do not remove a replacement ES device from its protective package until immediately before you are ready to install it. (Most replacement ES devices are packaged with leads electrically shorted together by conductive foam, aluminum foil or comparable conductive material).
7. Immediately before removing the protective material from the leads of a replacement ES device, touch the protective material to the chassis or circuit assembly into which the device will be installed.
CAUTION: Be sure no power is applied to the chassis or circuit, and observe all other safety precautions.
8. Minimize bodily motions when handling unpackaged replacement ES devices. (Otherwise harmless motion such as the brushing together of your clothes fabric or the lifting of your foot from a carpeted floor can generate static electricity sufficient to damage an ES device.)

General Soldering Guidelines

1. Use a grounded-tip, low-wattage soldering iron and appropriate tip size and shape that will maintain tip temperature within the range of 500° F to 600° F.
2. Use an appropriate gauge of RMA resin-core solder composed of 60 parts tin/40 parts lead.
3. Keep the soldering iron tip clean and well tinned.
4. Thoroughly clean the surfaces to be soldered. Use a small wire-bristle (0.5 inch, or 1.25cm) brush with a metal handle.

Do not use freon-propelled spray-on cleaners.

5. Use the following unsoldering technique
 - a. Allow the soldering iron tip to reach normal temperature.
(500° F to 600° F)
 - b. Heat the component lead until the solder melts.
 - c. Quickly draw the melted solder with an anti-static, suction-type solder removal device or with solder braid.

CAUTION: Work quickly to avoid overheating the circuitboard printed foil.

6. Use the following soldering technique.
 - a. Allow the soldering iron tip to reach a normal temperature (500° F to 600° F)
 - b. First, hold the soldering iron tip and solder the strand against the component lead until the solder melts.
 - c. Quickly move the soldering iron tip to the junction of the component lead and the printed circuit foil, and hold it there only until the solder flows onto and around both the component lead and the foil.

CAUTION: Work quickly to avoid overheating the circuit board printed foil.

- d. Closely inspect the solder area and remove any excess or splashed solder with a small wire-bristle brush.

IC Remove/Replacement

Some chassis circuit boards have slotted holes (oblong) through which the IC leads are inserted and then bent flat against the circuit foil. When holes are the slotted type, the following technique should be used to remove and replace the IC. When working with boards using the familiar round hole, use the standard technique as outlined in paragraphs 5 and 6 above.

Removal

1. Desolder and straighten each IC lead in one operation by gently prying up on the lead with the soldering iron tip as the solder melts.
2. Draw away the melted solder with an anti-static suction-type solder removal device (or with solder braid) before removing the IC.

Replacement

1. Carefully insert the replacement IC in the circuit board.
2. Carefully bend each IC lead against the circuit foil pad and solder it.
3. Clean the soldered areas with a small wire-bristle brush. (It is not necessary to reapply acrylic coating to the areas).

"Small-Signal" Discrete Transistor Removal/Replacement

1. Remove the defective transistor by clipping its leads as close as possible to the component body.
2. Bend into a "U" shape the end of each of three leads remaining on the circuit board.
3. Bend into a "U" shape the replacement transistor leads.
4. Connect the replacement transistor leads to the corresponding leads extending from the circuit board and crimp the "U" with long nose pliers to insure metal to metal contact then solder each connection.

Power Output, Transistor Device Removal/Replacement

1. Heat and remove all solder from around the transistor leads.
2. Remove the heat sink mounting screw (if so equipped).
3. Carefully remove the transistor from the heat sink of the circuit board.
4. Insert new transistor in the circuit board.
5. Solder each transistor lead, and clip off excess lead.
6. Replace heat sink.

Diode Removal/Replacement

1. Remove defective diode by clipping its leads as close as possible to diode body.
2. Bend the two remaining leads perpendicular y to the circuit board.
3. Observing diode polarity, wrap each lead of the new diode around the corresponding lead on the circuit board.
4. Securely crimp each connection and solder it.
5. Inspect (on the circuit board copper side) the solder joints of the two "original" leads. If they are not shiny, reheat them and if necessary, apply additional solder.

Fuse and Conventional Resistor Removal/Replacement

1. Clip each fuse or resistor lead at top of the circuit board hollow stake.
2. Securely crimp the leads of replacement component around notch at stake top.
3. Solder the connections.

CAUTION: Maintain original spacing between the replaced component and adjacent components and the circuit board to prevent excessive component temperatures.

Circuit Board Foil Repair

Excessive heat applied to the copper foil of any printed circuit board will weaken the adhesive that bonds the foil to the circuit board causing the foil to separate from or "lift-off" the board. The following guidelines and procedures should be followed whenever this condition is encountered.

At IC Connections

To repair a defective copper pattern at IC connections use the following procedure to install a jumper wire on the copper pattern side of the circuit board. (Use this technique only on IC connections).

1. Carefully remove the damaged copper pattern with a sharp knife. (Remove only as much copper as absolutely necessary).
2. Carefully scratch away the solder resist and acrylic coating (if used) from the end of the remaining copper pattern.
3. Bend a small "U" in one end of a small gauge jumper wire and carefully crimp it around the IC pin. Solder the IC connection.
4. Route the jumper wire along the path of the out-away copper pattern and let it overlap the previously scraped end of the good copper pattern. Solder the overlapped area and clip off any excess jumper wire.

At Other Connections

Use the following technique to repair the defective copper pattern at connections other than IC Pins. This technique involves the installation of a jumper wire on the component side of the circuit board.

1. Remove the defective copper pattern with a sharp knife.
Remove at least 1/4 inch of copper, to ensure that a hazardous condition will not exist if the jumper wire opens.
2. Trace along the copper pattern from both sides of the pattern break and locate the nearest component that is directly connected to the affected copper pattern.
3. Connect insulated 20-gauge jumper wire from the lead of the nearest component on one side of the pattern break to the lead of the nearest component on the other side.

Carefully crimp and solder the connections.

CAUTION: Be sure the insulated jumper wire is dressed so the it does not touch components or sharp edges.

TIMING CHART

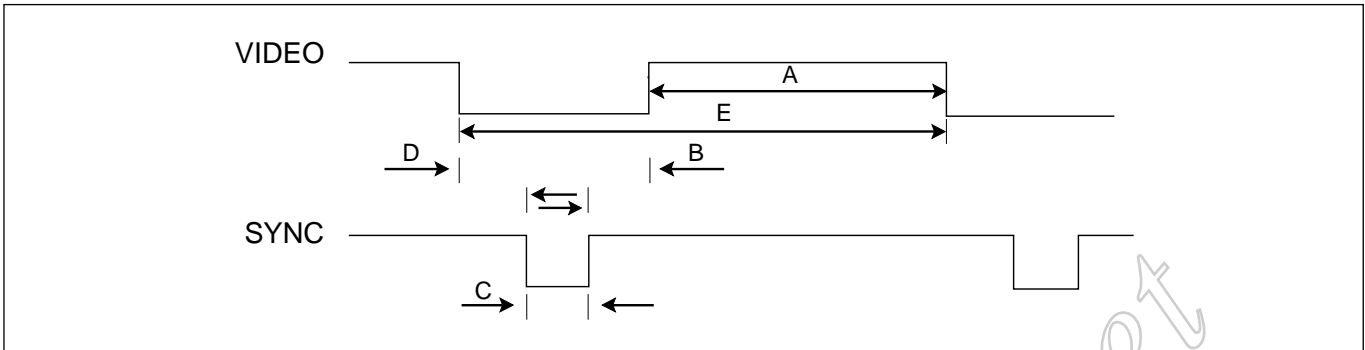

<< Dot Clock (MHz), Horizontal Frequency (kHz), Vertical Frequency (Hz), Horizontal etc... (μs), Vertical etc... (ms) >>

Mode	H/V Sort	Sync Polarity	Dot Clock	Frequency	Total Period (E)	Video Active Time (A)	Front Porch (C)	Sync Duration (D)	Back Porch (F)	Resolution
1	H	+	25.175	31.469	800	640	16	96	48	640x350 70Hz
	V	-		70.09	449	350	37	2	60	
2	H	-	28.321	31.468	900	720	18	108	54	720x400 70Hz
	V	+		70.08	449	400	12	2	35	
3	H	-	25.175	31.469	800	640	16	96	48	640x480 60Hz
	V	-		59.94	525	480	10	2	33	
4	H	-	31.5	37.5	840	640	16	64	120	640x480 75Hz
	V	-		75	500	480	1	3	16	
5	H	+	40.0	37.879	1056	800	40	128	88	800x600 60Hz
	V	+		60.317	628	600	1	4	23	
6	H	+	49.5	46.875	1056	800	16	80	160	800x600 75Hz
	V	+		75.0	625	600	1	3	21	
7	H	+/-	57.283	49.725	1152	832	32	64	224	832x624 75Hz
	V	+/-		74.55	667	624	1	3	39	
8	H	-	65.0	48.363	1344	1024	24	136	160	1024x768 60Hz
	V	-		60.0	806	768	3	6	29	
9	H	-	78.75	60.123	1312	1024	16	96	176	1024x768 75Hz
	V	-		75.029	800	768	1	3	28	
10	H	+/-	100.0	63.681	1456	1152	32	128	144	1152x900 75Hz
	V	+/-		75.062	915	870	3	3	39	
11	H	+/-	92.978	61.805	1504	1152	18	134	200	1152x900 65Hz
	V	+/-		65.96	937	900	2	4	31	
12	H	+	108.0	63.981	1688	1280	48	112	248	1280x1024 60Hz
	V	+		60.02	1066	1024	1	3	38	
13	H	+	135.0	79.976	1688	1280	16	144	248	1280x1024 75Hz
	V	+		75.035	1066	1024	1	3	38	

DISASSEMBLY

1

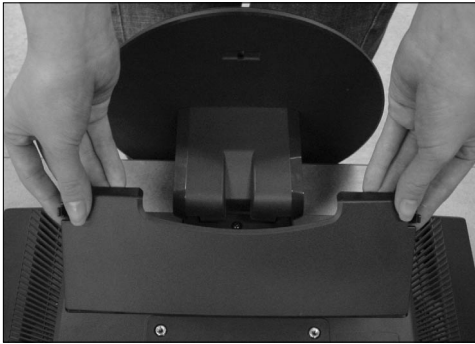

Disassembly Hinge Cover.

2

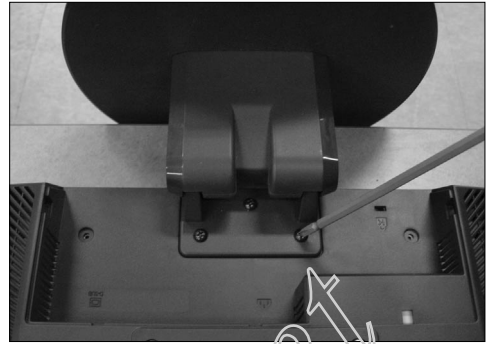

Remove the screws.

3



1. Pull the front cover upward.
2. Then, let the all latches are separated.
3. Put the front face down.

4

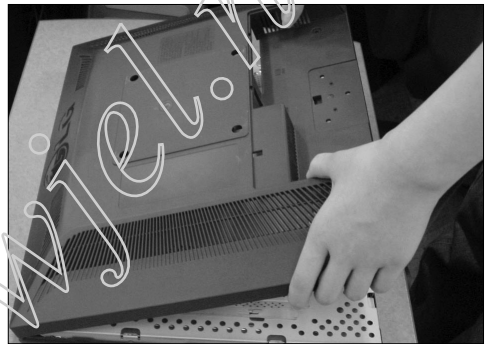

Disassemble back cover

5

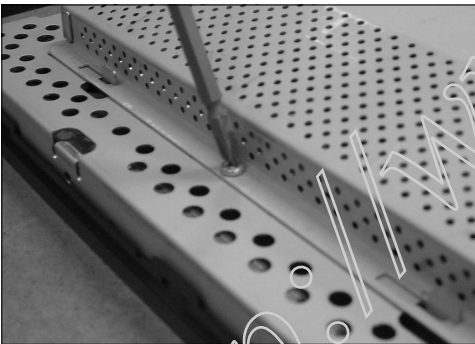

Remove the 6 screws from each up of metal frame.

6

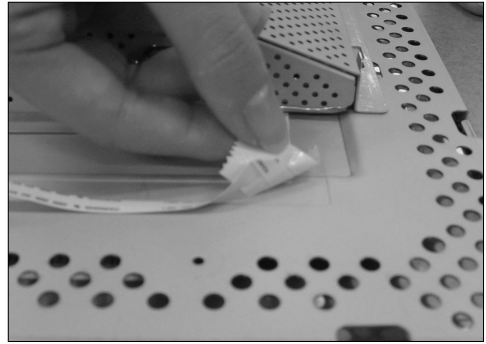

Pell off Al-tape from panel.

7

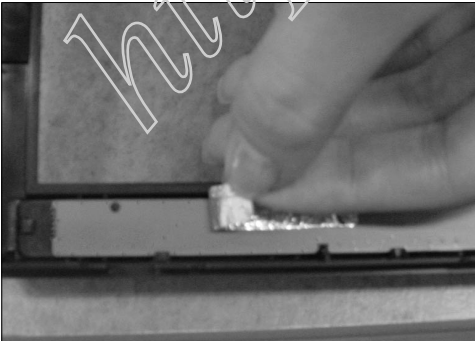

Remove Al-tape from control pcb fix.

8

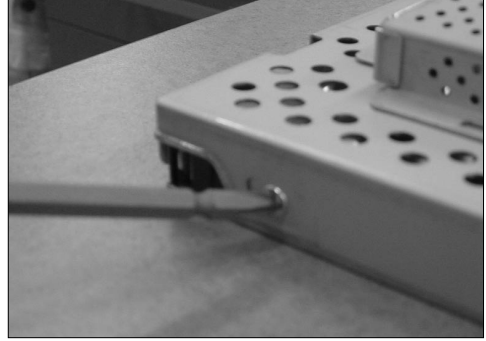

Remove the 4 screws from each side of metal frame

BLOCK DIAGRAM

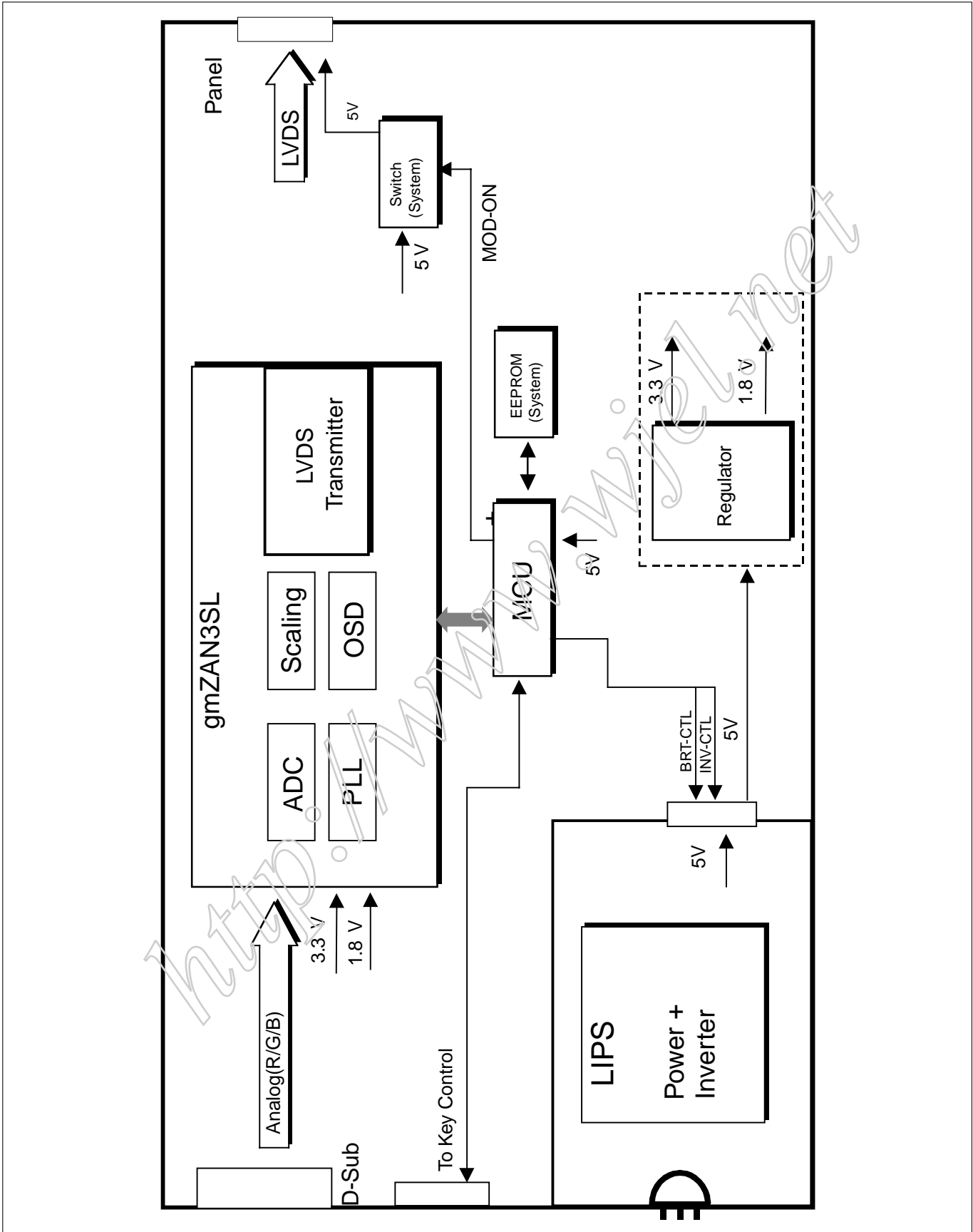

DESCRIPTION OF BLOCK DIAGRAM

1. Video Controller Part.

This part amplifies the level of video signal for the digital conversion and converts from the analog video signal to the digital video signal using a pixel clock.

The pixel clock for each mode is generated by the PLL.

The range of the pixel clock is from 25MHz to 135MHz.

This part consists of the Scaler, ADC, LVDS transmitter.

The Scaler gets the video signal converted analog to digital, interpolates input to 1280 X 1024 resolution signal and outputs 8-bit R, G, B signal to transmitter.

2. Power Part.

This part consists of the one 3.3V regulator, and one 1.8V regulator to convert power which is provided 12V, 5V in Power board.

5V is provided for LCD panel and Micom.

Also, 5V is converted 3.3V by regulator and 3.3V is converted 1.8V by regulator.

Converted power is provided for IC in the main board.

3. MICOM Part.

This part consists of EEPROM IC which stores control data, Reset IC and the Micom.

The Micom distinguishes polarity and frequency of the H/V sync are supplied from signal cable.

The controlled data of each modes is stored in EEPROM.

LIPS Board Block Diagram

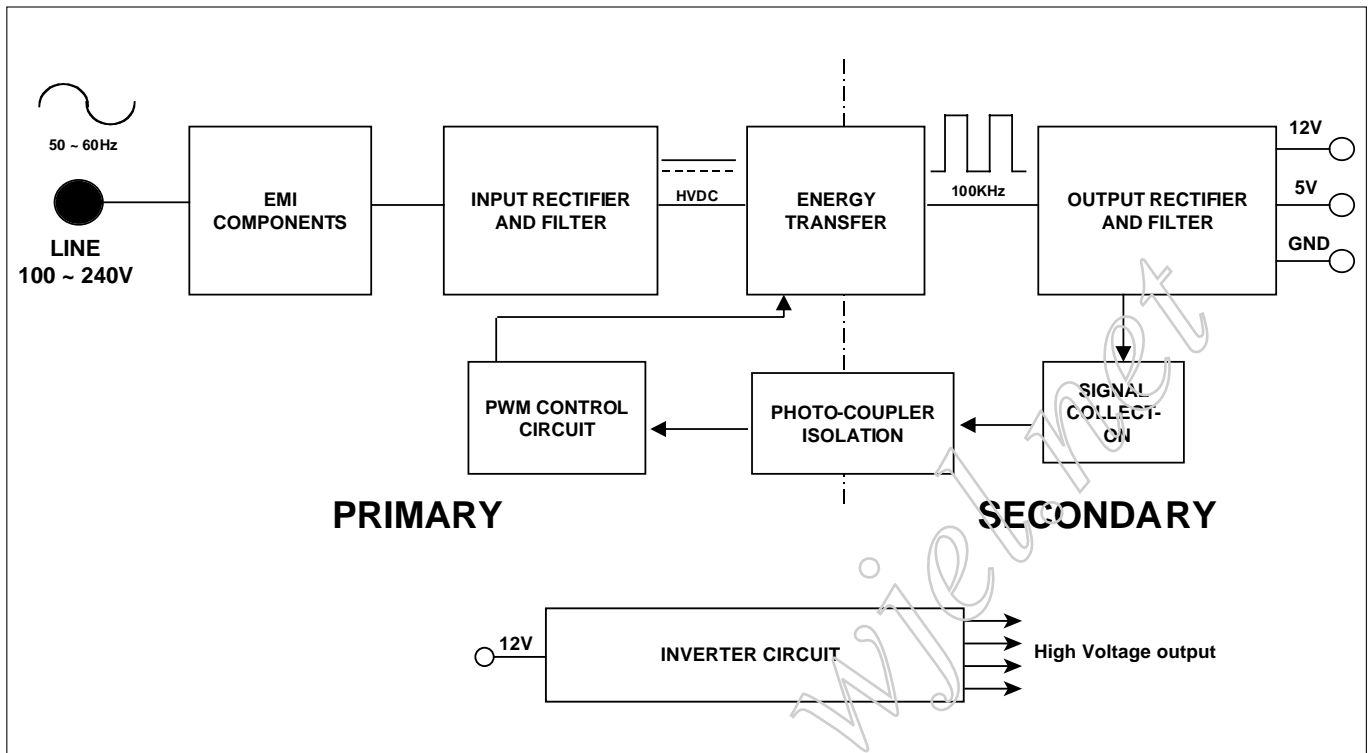

Operation description_LIPS

1. EMI components.

This part contains of EMI components to comply with global marketing EMI standards like FCC, VCCI CISPR, the circuit included a line-filter, across line capacitor and of course the primary protection fuse.

2. Input rectifier and filter.

This part function is for transfer the input AC voltage to a DC voltage through a bridge rectifier and a bulk capacitor.

3. Energy Transfer.

This part function is transfer the primary energy to secondary through a power transformer.

4. Output rectifier and filter.

This part function is to make a pulse width modulation control and to provide the driver signal to power switch, to adjust the duty cycle during different AC input and output loading condition to achive the dc output stabilize, and also the over power protection is also monitor by this part.

5. Photo-Coupler isolation.

This part function is to feed back the dc output changing status through a photo transistor to primary controller to achieve the stabilized dc output voltage.

6. Signal collection.

This part function is to collect the any change from the dc output and feed back to the primary through photo transistor.

ADJUSTMENT

Windows EDID V1.0 User Manual

Operating System: MS Windows 98, 2000, XP
 Port Setup: Windows 98 => Don't need setup
 Windows 2000, XP => Need to Port Setup.
 This program is available to LCD Monitor only.

2. EDID Read & Write
 - 1) Run WinEDID.exe

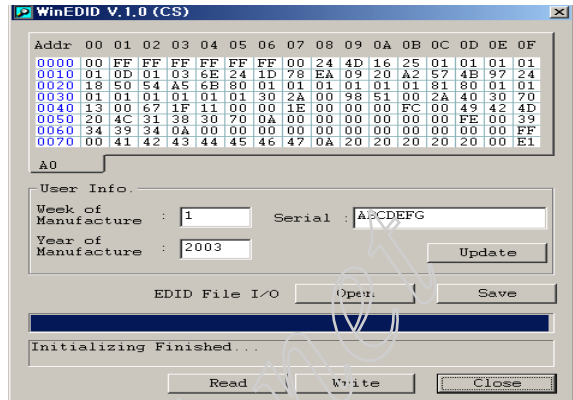

1. Port Setup

- a) Copy "UserPort.sys" file to "c:\WINNT\system32\drivers" folder
- b) Run Userport.exe

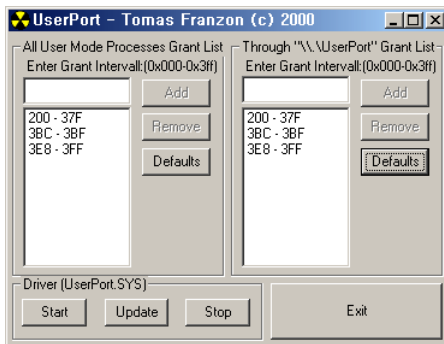

- 2) Edit Week of Manufacture, Year of Manufacture, Serial Number

- a) Input User Info Data
- b) Click "Update" button
- c) Click "Write" button

- c) Remove all default number
- d) Add 300-3FF

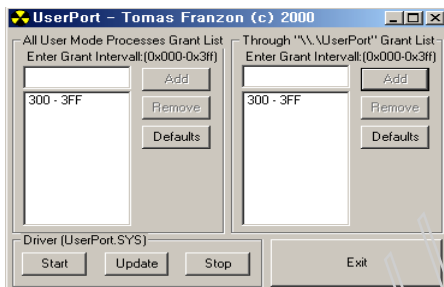

- e) Click Start button.
- f) Click Exit button.

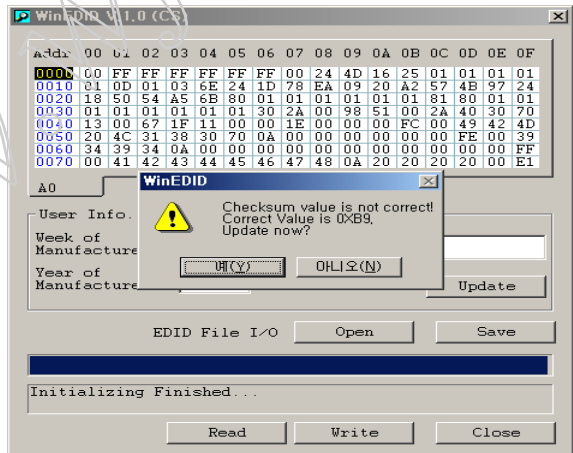

SERVICE OSD

- 1) Turn off the power switch at the front side of the display.
- 2) Wait for about 5 seconds and press MENU, POWER switch with 1 second interval.
- 3) The SVC OSD menu contains additional menus that the User OSD menu as described below.
 - a) Auto Color : W/B balance and Automatically sets the gain and offset value.
 - b) NVRAM INIT : EEPROM initialize.(24C08)
 - c) CLEAR ETI : To initialize using time.
 - d) AGING : Select Aging mode(on/off).
 - e) R/G/B-9300K : Allows you to set the R/G/B-9300K value manually.
 - f) R/G/B-6500K : Allows you to set the R/G/B-6500K value manually.
 - g) R/G/B-Offset : Allows you to set the R/G/B-Offset value manually.(Analog Only)
 - h) R/G/B-Gain : Allows you to set the R/G/B-Gain value manually.(Analog Only)
 - i) MODULE : To select applied module.

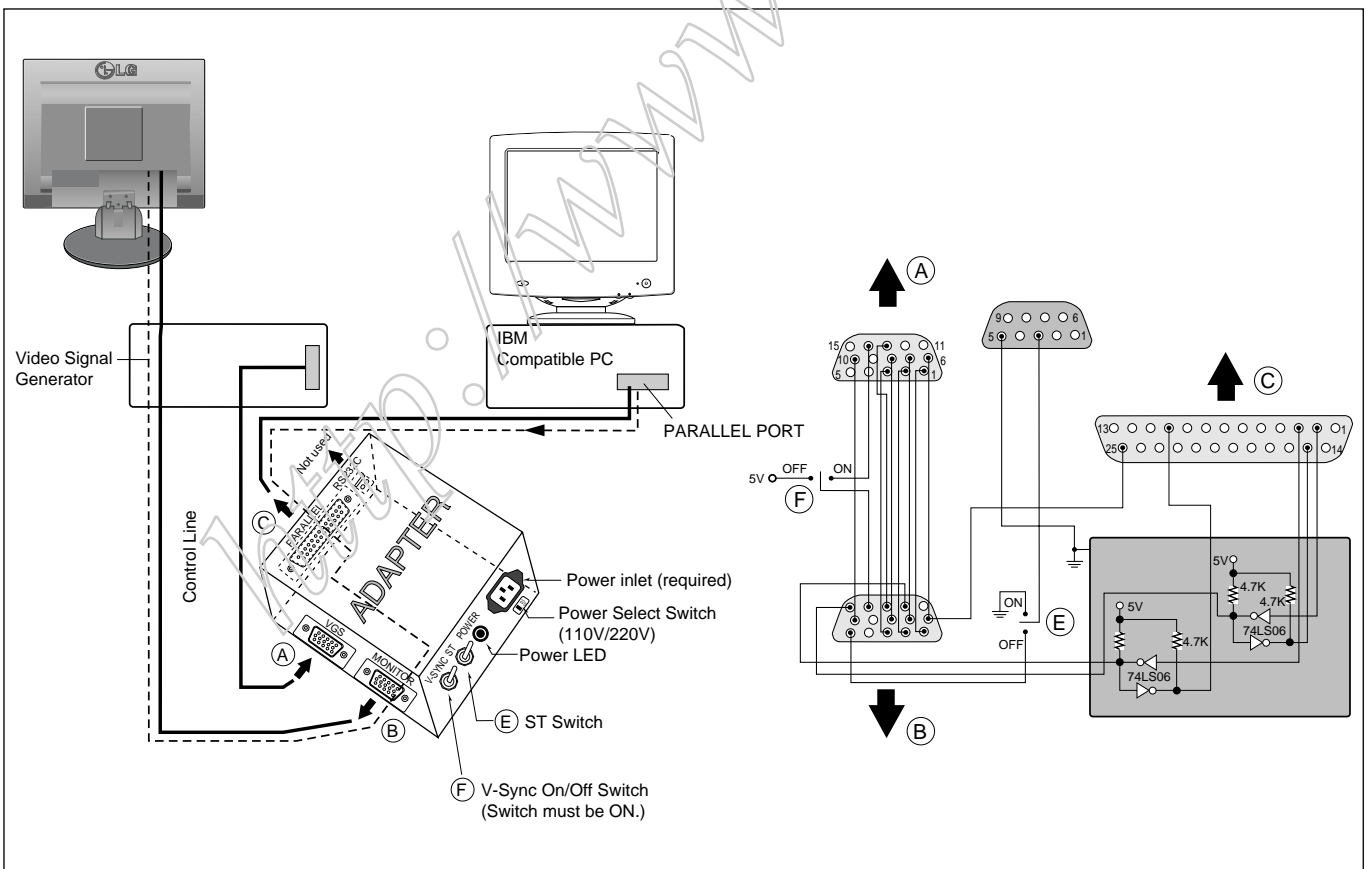
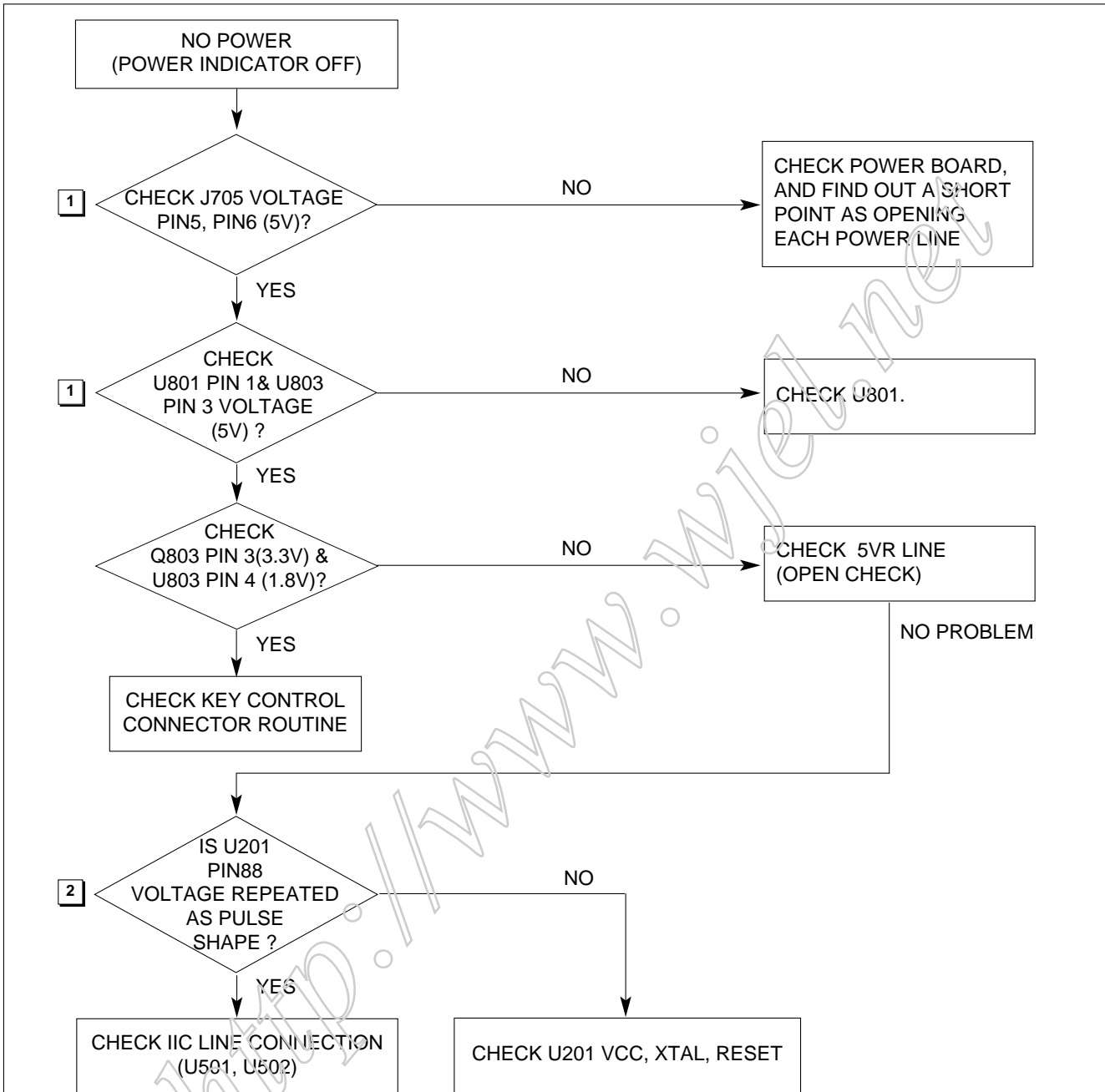

Figure 1. Cable Connection

TROUBLESHOOTING GUIDE

1. NO POWER



Waveforms

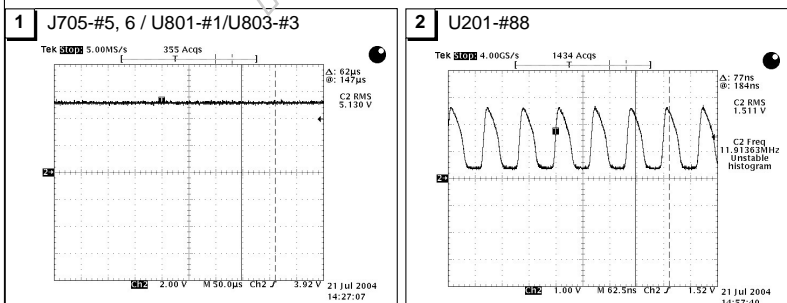

2. NO RASTER (OSD IS NOT DISPLAYED) – LIPS

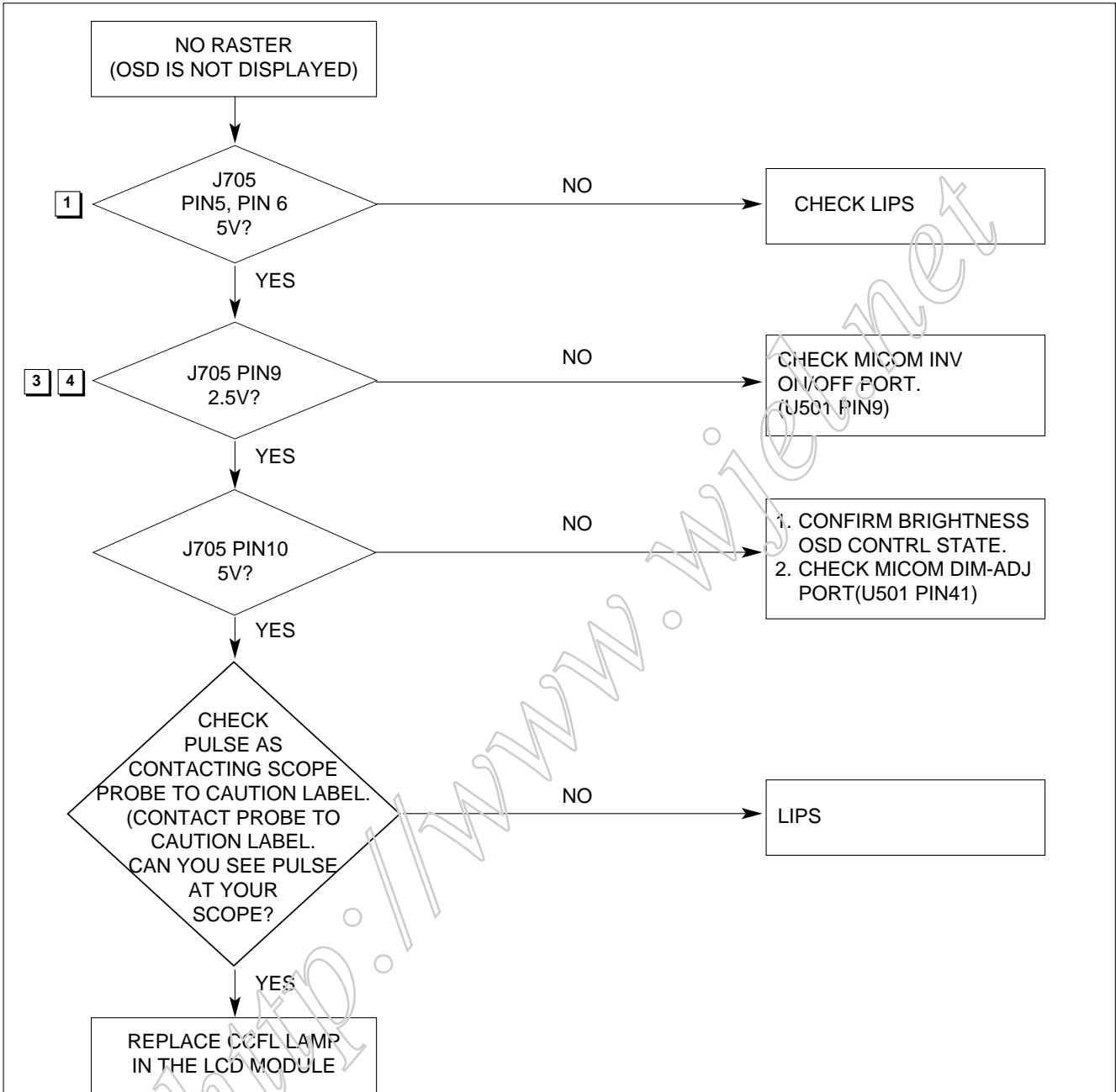

Waveforms

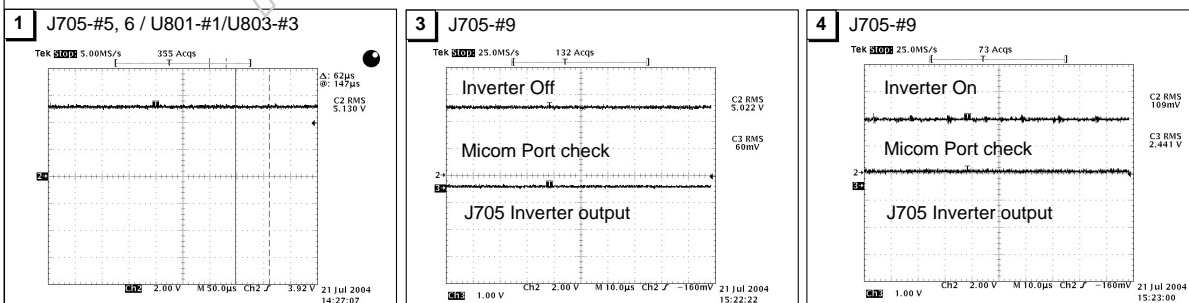

3. NO RASTER (OSD IS NOT DISPLAYED) – gmZAN3SL

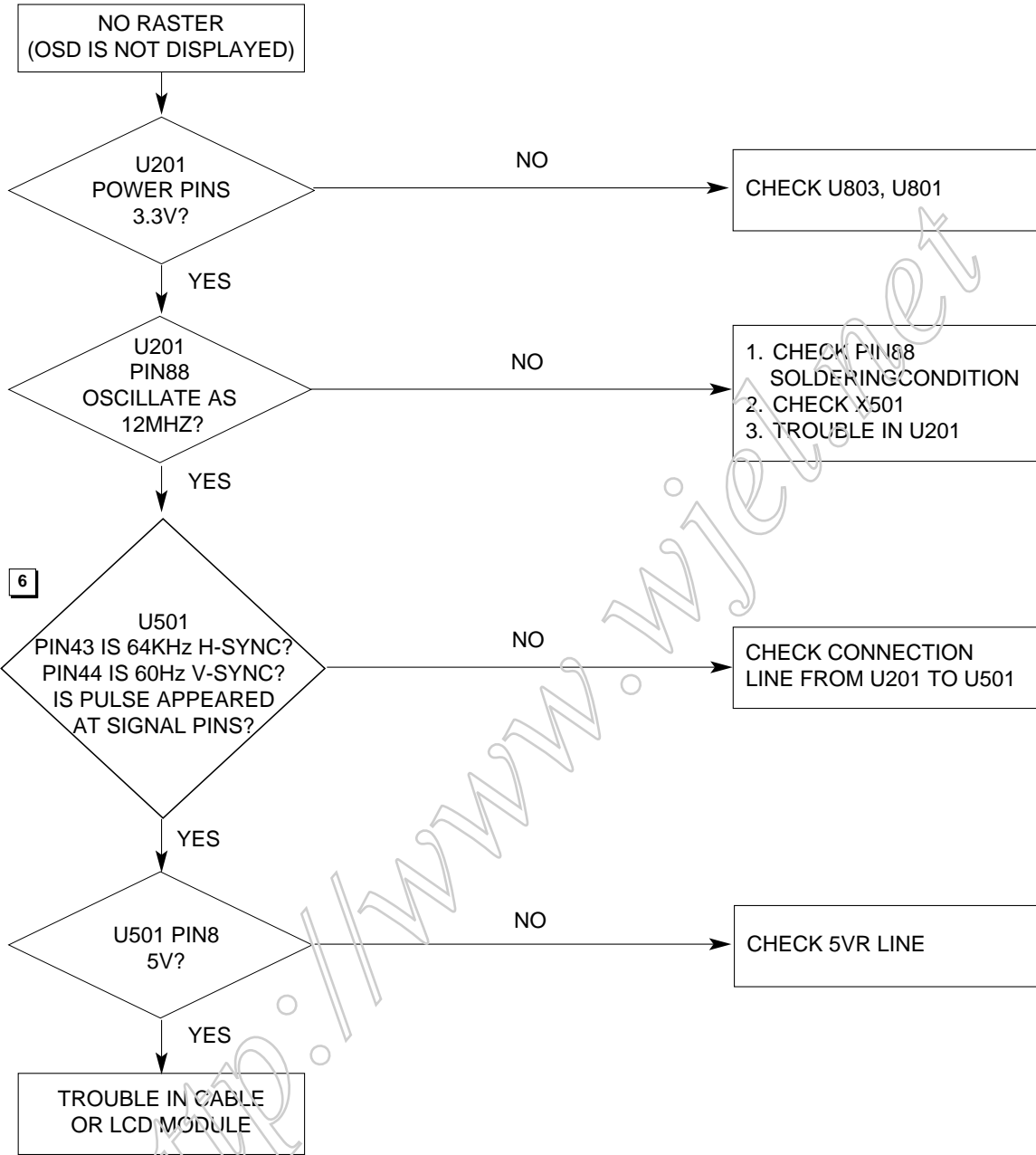

Waveforms

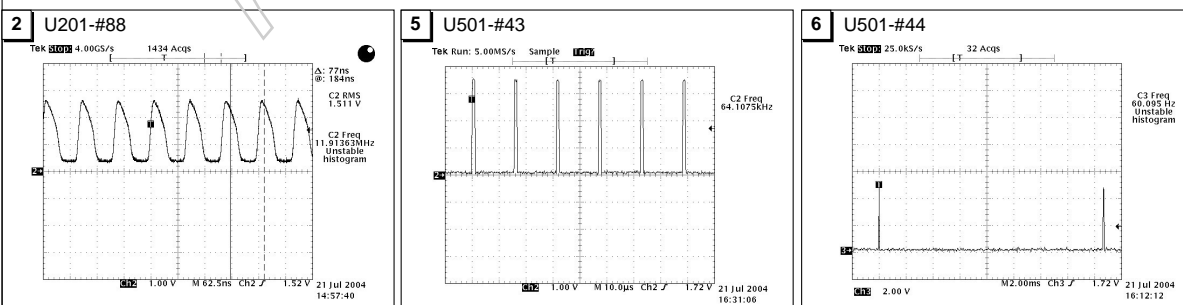

4. NO RASTER (OSD IS DISPLAYED) – gmZAN3SL

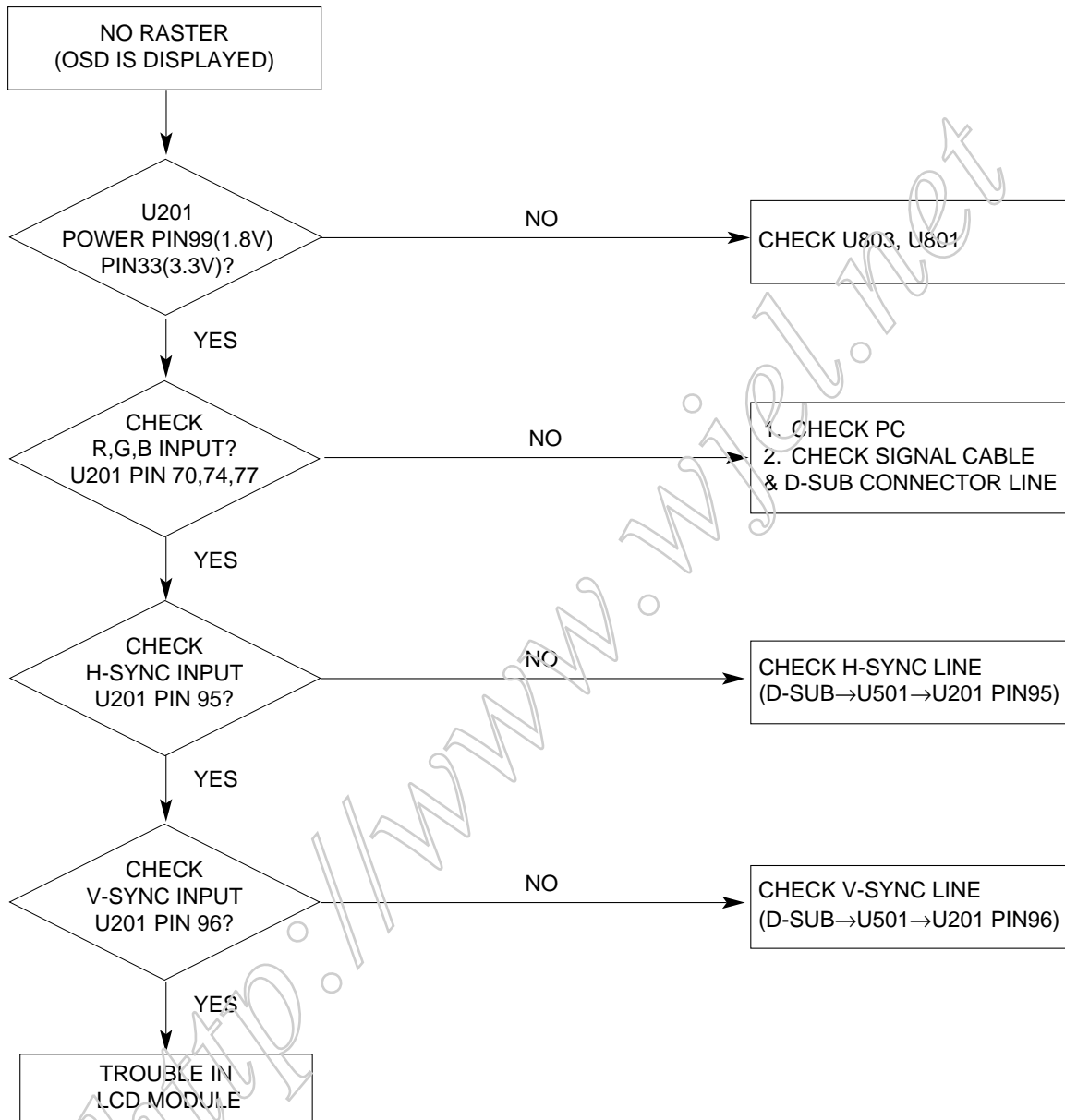

WIRING DIAGRAM

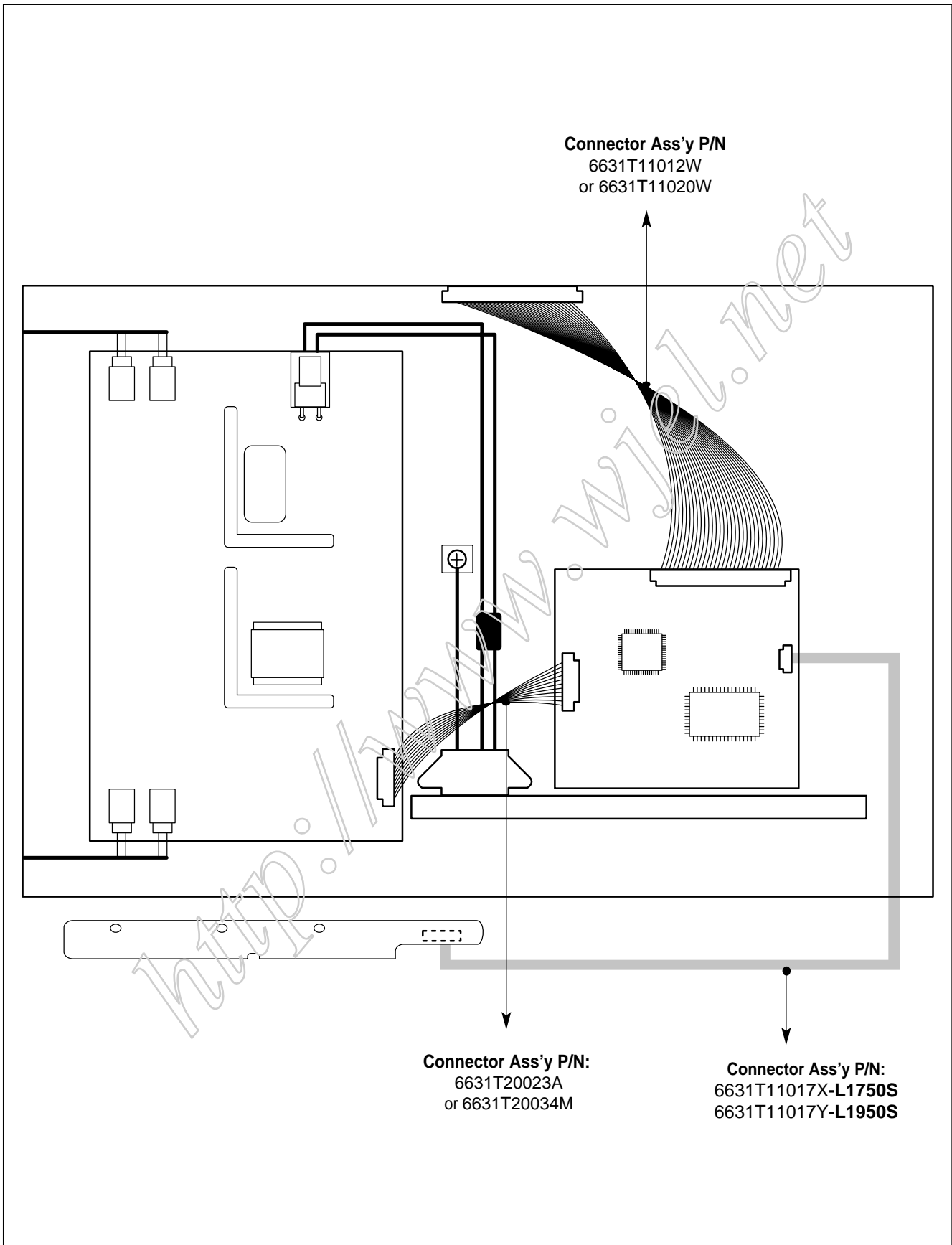

EXPLODED VIEW

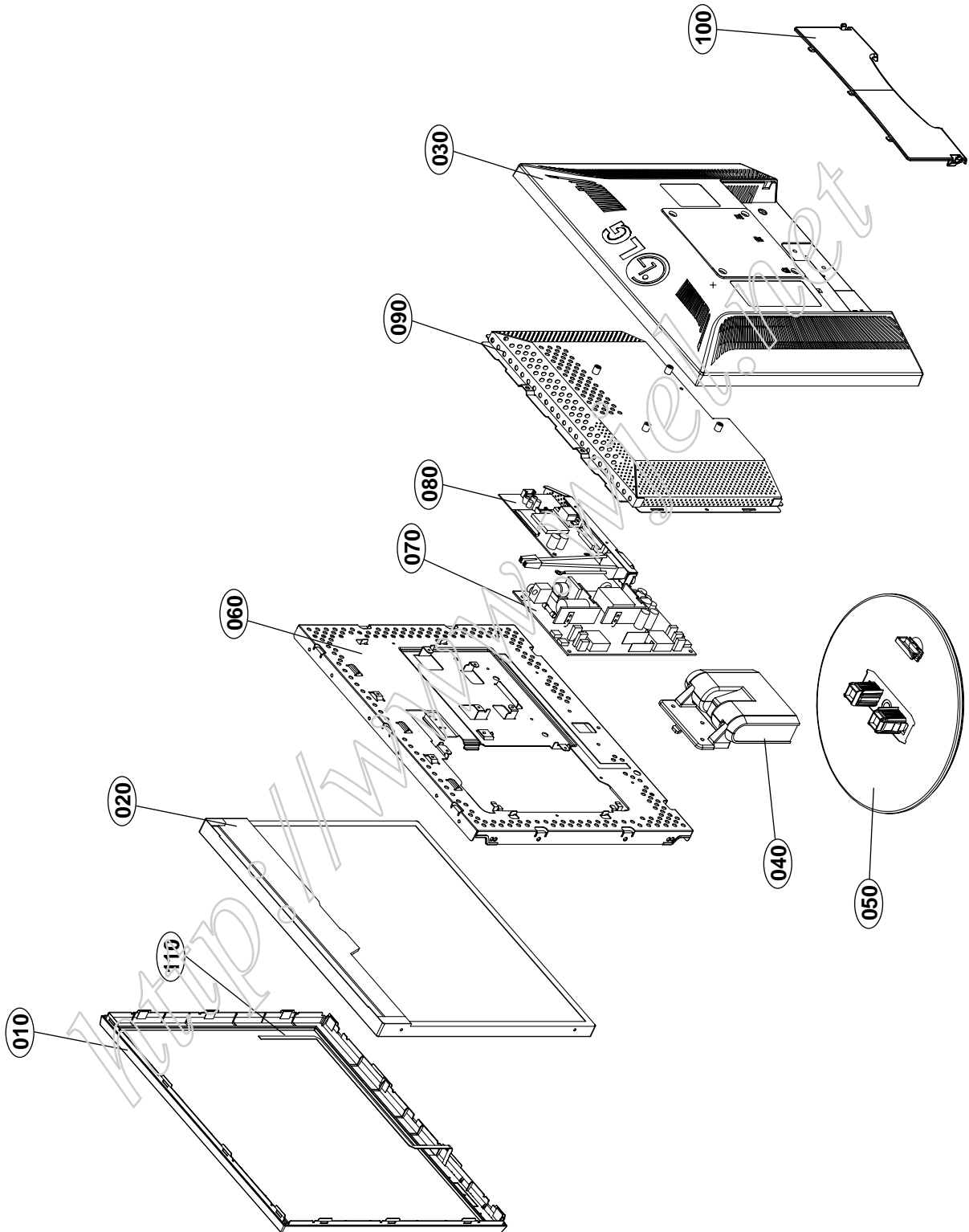

EXPLODED VIEW PARTS LIST

Ref. No.	Part No.	Description
010	3091TKL143N	CABINET ASSEMBLY, L1750S BRAND L122 SILVER PC+ABS,89483 TCO03 US-VER
	3091TKL143R	CABINET ASSEMBLY, L1750S BRAND L122 SILVER PC+ABS TCO03+12MS FLATRON N-C/SKD
	3091TKL144N	CABINET ASSEMBLY, L1950S BRAND L123 SILVER PC+ABS,89483 TCO03
	3091TKL144Q	CABINET ASSEMBLY, L1950S BRAND L123 SILVER PC+ABS 12MS+TCO03, US N-C/SKD
020	6304FLP110B	LCD(LIQUID CRYSTAL DISPLAY), LM170E01-A5N5 LG PHILPS TFT COLOR PART NUMBER CHANGE FOR COST COMPENSATION
	or 6304FLP086A	LCD(LIQUID CRYSTAL DISPLAY), LM170E01-A5K6 LG PHILPS TFT COLOR LVDS SXGA OKI GATE D-IC
	or 6304FLP194A	LCD(LIQUID CRYSTAL DISPLAY), LM170E01-A5K2 LG PHILPS TFT COLOR TI D-IC,250NITS,SXGA,LVDS
	or 6304FLP110A	LCD(LIQUID CRYSTAL DISPLAY), LM170E01-A5N5 LG PHILPS TFT COLOR LPL NJ,250NITS,SXGA,LVDS
	or 6304FLP160A	LCD(LIQUID CRYSTAL DISPLAY), LM170E01-A5KS LG PHILPS TFT COLOR NEC D-IC,250NITS,SXGA,LVDS
	6304FLP142A	LCD(LIQUID CRYSTAL DISPLAY), LM190E03-B4K1 LG PHILPS TFT COLOR 20T,TN,250NITS,SXGA,LVDS
	or 6304FLP184A	LCD(LIQUID CRYSTAL DISPLAY), LM190E03-B4N2 LG PHILPS TFT COLOR B4K1 LPL NJ,20T,TN,250NITS,SXGA,LVDS
030	3809TKL100E	BACK COVER ASSEMBLY, L1750S L100 PC+ABS 9930(BK) US-VER
	3809TKL100G	BACK COVER ASSEMBLY, L1750S L100 PC+ABS 9930(BK) ANALOG US-VER E-C/SKD
	3809TKL101E	BACK COVER ASSEMBLY, L1950S L101 BRAND PC+ABS 9930(BK) US-VER
	3809TKL101F	BACK COVER ASSEMBLY, L1950S L101 BRAND PC+ABS 9930(BK) US-VER E-C/SKD
040	3043TKK227A	TILT SWIVEL ASSEMBLY, L1750S - TILT STAND BODY
	3043TKK227C	TILT SWIVEL ASSEMBLY, L1750S - TILT STAND BODY A-C/SKD
	3043TKK227B	TILT SWIVEL ASSEMBLY, L1950S - TILT STAND BODY.
	3043TKK227D	TILT SWIVEL ASSEMBLY, L1950S - TILT STAND BODY B-C/SKD
050	3043TKK228A	TILT SWIVEL ASSEMBLY, L1750S - TILT STAND BASE
	3043TKK228B	TILT SWIVEL ASSEMBLY, LX 50S - TILT STAND BASE A-C/SKD
060	4951TKS199A	METAL ASSEMBLY, FRAME MAIN L1750 LPL-A5 KUMI
	4951TKS199B	METAL ASSEMBLY, FRAME MAIN L1750 A-C/SKD
	4951TKS200A	METAL ASSEMBLY, FRAME MAIN L1950 LPL-E03 TN/AUO-EN04-V2 KUMI
	4951TKS200C	METAL ASSEMBLY, FRAME MAIN L1950 LPL-E03 TN/AUO-EN04-V2 A-C/SKD
070	6871TPT282C	PWB(PCB) ASSEMBLY,POWER, M-CHASSIS 1720 DOCKING,2PIN,450V POWER TOTAL LIEN CHANG PB FREE- L1750S
	6871TPT282Q	PWB(PCB) ASSEMBLY,POWER, M-CHASSIS 19INCH TN & 1720 DOCKING,2PIN,450V POWER TOTAL LIEN CHANG PB FREE & ANALOG- L1950S
080	3313TL7087A	MAIN TOTAL ASSEMBLY, L1750SN LPL ZAN3SL BRAND CL-66
	3313TL7087E	MAIN TOTAL ASSEMBLY, L1750SN LPL ZAN3SL MX C/SKD BRAND CL-82 LF
	3313TL9078A	MAIN TOTAL ASSEMBLY, L1950SN LPL ZAN3SL BRAND CL-66
	3313TL9078E	MAIN TOTAL ASSEMBLY, L1950SN LPL ZAN3SL MX C/SKD BRAND CL-82 LF
090	4951TKS203A	METAL ASSEMBLY, REAR SHIELD LX50 KUMI
	4951TKS203B	METAL ASSEMBLY, REAR SHIELD LX50 KUMI A-C/SKD
100	3550TKK740A	COVER, L1750 BACK DOOR BRAND
	3550TKK740B	COVER, L1750 BACK DOOR BRAND A-C/SKD
	3550TKK741A	COVER, L1950 BACK DOOR BRAND
	3550TKK741B	COVER, L1950 BACK DOOR BRAND A-C/SKD
110	6871TST798A	PWB(PCB) ASSEMBLY,SUB, L1750 CONTROL TOTAL BRAND KEY
	6871TST798C	PWB(PCB) ASSEMBLY,SUB, L1750 CONTROL TOTAL BRAND MX C/SKD LF
	6871TST911A	PWB(PCB) ASSEMBLY,SUB, L1950 CONTROL TOTAL BRAND KEY
	6871TST911C	PWB(PCB) ASSEMBLY,SUB, L1950 CONTROL TOTAL BRAND MX C/SKD LF

REPLACEMENT PARTS LIST

CAUTION: BEFORE REPLACING ANY OF THESE COMPONENTS,
 READ CAREFULLY THE **SAFETY PRECAUTIONS** IN THIS MANUAL.

* NOTE : **S** SAFETY Mark \triangle
AL ALTERNATIVE PARTS

DATE: 2004. 12. 17.				
*S	*AL	LOC. NO.	PART NO.	DESCRIPTION / SPECIFICATION
MAIN BOARD				
CAPACITORS				
		C204	0CK103CK51A	0.01UF 1608 50V 10% R/TP B(Y)
		C205	0CK103CK51A	0.01UF 1608 50V 10% R/TP B(Y)
		C206	0CK103CK51A	0.01UF 1608 50V 10% R/TP B(Y)
		C207	0CK103CK51A	0.01UF 1608 50V 10% R/TP B(Y)
		C208	0CK103CK51A	0.01UF 1608 50V 10% R/TP B(Y)
		C210	0CK103CK51A	0.01UF 1608 50V 10% R/TP B(Y)
		C213	0CK103CK51A	0.01UF 1608 50V 10% R/TP B(Y)
		C214	0CK103CK51A	0.01UF 1608 50V 10% R/TP B(Y)
		C215	0CK103CK51A	0.01UF 1608 50V 10% R/TP B(Y)
		C216	0CK103CK51A	0.01UF 1608 50V 10% R/TP B(Y)
		C217	0CK103CK51A	0.01UF 1608 50V 10% R/TP B(Y)
		C218	0CK103CK51A	0.01UF 1608 50V 10% R/TP B(Y)
		C219	0CK103CK51A	0.01UF 1608 50V 10% R/TP B(Y)
		C220	0CK103CK51A	0.01UF 1608 50V 10% R/TP B(Y)
		C221	0CK103CK51A	0.01UF 1608 50V 10% R/TP B(Y)
		C222	0CK103CK51A	0.01UF 1608 50V 10% R/TP B(Y)
		C223	0CK103CK51A	0.01UF 1608 50V 10% R/TP B(Y)
		C224	0CK103CK51A	0.01UF 1608 50V 10% R/TP B(Y)
		C225	0CK103CK51A	0.01UF 1608 50V 10% R/TP B(Y)
		C226	0CK103CK51A	0.01UF 1608 50V 10% R/TP B(Y)
		C227	0CK103CK51A	0.01UF 1608 50V 10% R/TP B(Y)
		C231	0CK103CK51A	0.01UF 1608 50V 10% R/TP B(Y)
		C232	0CK103CK51A	0.01UF 1608 50V 10% R/TP B(Y)
		C233	0CK103CK51A	0.01UF 1608 50V 10% R/TP B(Y)
		C234	0CK103CK51A	0.01UF 1608 50V 10% R/TP B(Y)
		C503	0CK103CK51A	0.01UF 1608 50V 10% R/TP B(Y)
		C504	0CE106CK610	"10UF SHL,SD 50V 20% BULK FL."
		C506	0CC030CK01A	3PF 1608 50V 0.25 PF R/TP NP
		C507	0CC180CK41A	18PF 1608 50V 5% R/TP NP0
		C508	0CK103CK51A	0.01UF 1608 50V 10% R/TP B(Y)
		C701	0CK105CD56A	1UF 1608 10V 10% R/TP X7R
		C708	0CK103CK51A	0.01UF 1608 50V 10% R/TP B(Y)
		C709	0CK103CK51A	0.01UF 1608 50V 10% R/TP B(Y)
		C717	0CC101CK41A	100PF 1608 50V 5% R/TP NP0
		C718	0CC101CK41A	100PF 1608 50V 5% R/TP NP0
		C720	0CC680CK41A	68PF 1608 50V 5% R/TP NP0
		C721	0CC680CK41A	68PF 1608 50V 5% R/TP NP0
		C727	0CK105CD56A	1UF 1608 10V 10% R/TP X7R
		C732	0CK103CK51A	0.01UF 1608 50V 10% R/TP B(Y)
		C733	0CK104CK56A	0.1UF 1608 50V 10% R/TP X7R
		C734	0CK104CK56A	0.1UF 1608 50V 10% R/TP X7R
		C735	0CK104CK56A	0.1UF 1608 50V 10% R/TP X7R
		C801	0CK103CK51A	0.01UF 1608 50V 10% R/TP B(Y)
		C803	0CK104CK56A	0.1UF 1608 50V 10% R/TP X7R- L1750S
		C819	0CK103CK51A	0.01UF 1608 50V 10% R/TP B(Y)
		C820	0CE107EF610	"100UF KMG,RD 16V 20% FL BULK"
		C820	0CE107EF628	"100UF KMG,RD 16V 20% FM2.5 T"- C/SKD
		C821	0CK103CK51A	0.01UF 1608 50V 10% R/TP B(Y)
		C829	0CK103CK51A	0.01UF 1608 50V 10% R/TP B(Y)
		C831	0CE107EF610	"100UF KMG,RD 16V 20% FL BULK"
		C831	0CE107EF628	"100UF KMG,RD 16V 20% FM2.5 T"- C/SKD
		C832	0CE107EF610	"100UF KMG,RD 16V 20% FL BULK"- C/SKD

DATE: 2004. 12. 17.				
*S	*AL	LOC. NO.	PART NO.	DESCRIPTION / SPECIFICATION
		C832	0CE107EF628	"100UF KMG,RD 16V 20% FM2.5 T"
		C833	0CK105CD56A	1UF 1608 10V 10% R/TP X7R- L1950S
		C834	0CC102CK41A	1000PF 1608 50V 5% R/TP NP0- L1950S
DIODES				
		D701	0DS226009AA	KDS226 TP KEC SOT-23 80V 30
		D702	0DS226003AA	KDS226 TP KEC SOT-23 80V 30
		D706	0DS226009AA	KDS226 TP KEC SOT-23 80V 30
		ZD701	0DZKE00138A	KDZ5.6V KEC R/TP USC 0.2W 5.
		ZD702	0DZKE00138A	KDZ5.6V KEC R/TP USC 0.2W 5.
		ZD703	0DZKE00138A	KDZ5.6V KEC R/TP USC 0.2W 5.
		ZD704	0DZKE00138A	KDZ5.6V KEC R/TP USC 0.2W 5.
		ZD705	0DZKE00138A	KDZ5.6V KEC R/TP USC 0.2W 5.
		ZD711	0DZKE00138A	KDZ5.6V KEC R/TP USC 0.2W 5.
ICs				
		U201	0IPRPGN016B	"GMZAN3SL-BD-LF GENESIS 128P,"
		U501	0IZZTSZ594A	L1750SN ZAN3SL MICOM ASSY - L1750S
		U502	0ISG240860B	"M24C08WMN6T(P),LF SGS-THOMSO"
		U801	0IPMGKE011A	KIA78D33F KEC DPAK R/TP 3.3V
		U803	0IPMGSG019A	"LD1117S18TR,LF STM SOT223 R"
		Q502	0IKE704200H	KIA7042AP TO-92 TP 4.2 VOLT
TRANSISTOR				
		Q503	0TR390409AE	FAIRCHILD KST3904(LGEMTF) TP
		Q504	0TR390409AE	FAIRCHILD KST3904(LGEMTF) TP
		Q505	0TR390409AE	FAIRCHILD KST3904(LGEMTF) TP
		Q703	0TR390609FA	KST3906-MTF TP SAMSUNG SOT2
		Q704	0TR390609FA	KST3906-MTF TP SAMSUNG SOT2
		Q803	0TR127309AA	KTA1273-Y(KTA966A) TP KEC TO- L1750S
		Q804	0TR390409AE	FAIRCHILD KST3904(LGEMTF) TP- L1750S
		U802	0TFV180023A	VISHAY SI3865DV R/TP TSOP-6- L1950S
RESISTORS				
		R201	0RJ1000D677	100 OHM 1/10 W 5% 1608 R/TP
		R202	0RJ1000D677	100 OHM 1/10 W 5% 1608 R/TP
		R203	0RJ1000D677	100 OHM 1/10 W 5% 1608 R/TP
		R208	0RJ1200D677	120 OHM 1/10 W 5% 1608 R/TP
		R209	0RJ1200D677	120 OHM 1/10 W 5% 1608 R/TP
		R210	0RJ1200D677	120 OHM 1/10 W 5% 1608 R/TP
		R211	0RJ1000D677	100 OHM 1/10 W 5% 1608 R/TP
		R213	0RJ0000D677	0 OHM 1/10 W 5% 1608 R/TP
		R214	0RJ0000D677	0 OHM 1/10 W 5% 1608 R/TP
		R220	0RJ0000D677	0 OHM 1/10 W 5% 1608 R/TP
		R221	0RJ0000D677	0 OHM 1/10 W 5% 1608 R/TP
		R222	0RJ1004D677	1000000 OHM 1/10 W 5% 1608 R
		R506	0RJ4701D677	4.7K OHM 1/10 W 5% 1608 R/TP
		R508	0RJ4701D677	4.7K OHM 1/10 W 5% 1608 R/TP
		R514	0RJ4701D677	4.7K OHM 1/10 W 5% 1608 R/TP
		R515	0RJ4701D677	4.7K OHM 1/10 W 5% 1608 R/TP

DATE: 2004. 12. 17.				
*S	*AL	LOC. NO.	PART NO.	DESCRIPTION / SPECIFICATION
		R516	0RJ4701D677	4.7K OHM 1/10 W 5% 1608 R/TP
		R518	0RJ4701D677	4.7K OHM 1/10 W 5% 1608 R/TP
		R520	0RJ4701D677	4.7K OHM 1/10 W 5% 1608 R/TP
		R521	0RJ4701D677	4.7K OHM 1/10 W 5% 1608 R/TP
		R522	0RJ4701D677	4.7K OHM 1/10 W 5% 1608 R/TP
		R523	0RJ4701D677	4.7K OHM 1/10 W 5% 1608 R/TP
		R534	0RJ0000D677	0 OHM 1/10 W 5% 1608 R/TP
		R535	0RJ3301D677	3.3K OHM 1/10 W 5% 1608 R/TP
		R537	0RJ3301D677	3.3K OHM 1/10 W 5% 1608 R/TP
		R541	0RJ1000D677	100 OHM 1/10 W 5% 1608 R/TP
		R542	0RJ1000D677	100 OHM 1/10 W 5% 1608 R/TP
		R543	0RJ4701D677	4.7K OHM 1/10 W 5% 1608 R/TP
		R544	0RJ4701D677	4.7K OHM 1/10 W 5% 1608 R/TP
		R545	0RJ4700D677	470 OHM 1/10 W 5% 1608 R/TP
		R547	0RJ4700D677	470 OHM 1/10 W 5% 1608 R/TP
		R548	0RJ0332D677	33 OHM 1/10 W 5% 1608 R/TP
		R549	0RJ0332D677	33 OHM 1/10 W 5% 1608 R/TP
		R555	0RJ1000D677	100 OHM 1/10 W 5% 1608 R/TP
		R557	0RJ1000D677	100 OHM 1/10 W 5% 1608 R/TP
		R560	0RJ1501D677	1.5K OHM 1/10 W 5% 1608 R/TP-L1750S
		R560	0RJ4702D677	47000 OHM 1/10 W 5% 1608 R/TP-L1950S
		R561	0RJ4701D677	4.7K OHM 1/10 W 5% 1608 R/TP
		R566	0RJ1002D677	10K OHM 1/10 W 5% 1608 R/TP
		R701	0RJ0752D677	75 OHM 1/10 W 5% 1608 R/TP
		R703	0RJ0752D677	75 OHM 1/10 W 5% 1608 R/TP
		R706	0RJ0752D677	75 OHM 1/10 W 5% 1608 R/TP
		R708	0RJ4700D677	470 OHM 1/10 W 5% 1608 R/TP
		R709	0RJ1001D677	1K OHM 1/10 W 5% 1608 R/TP
		R716	0RJ4701D677	4.7K OHM 1/10 W 5% 1608 R/TP
		R717	0RJ4701D677	4.7K OHM 1/10 W 5% 1608 R/TP
		R720	0RJ0000D677	0 OHM 1/10 W 5% 1608 R/TP
		R721	0RJ4700D677	470 OHM 1/10 W 5% 1608 R/TP
		R722	0RJ1000D677	100 OHM 1/10 W 5% 1608 R/TP
		R723	0RJ0682D677	68 OHM 1/10 W 5% 1608 R/TP
		R724	0RJ0682D677	68 OHM 1/10 W 5% 1608 R/TP
		R726	0RJ1002D677	10K OHM 1/10 W 5% 1608 R/TP
		R727	0RJ1002D677	10K OHM 1/10 W 5% 1608 R/TP
		R737	0RJ0000D677	0 OHM 1/10 W 5% 1608 R/TP
		R744	0RJ4701D677	4.7K OHM 1/10 W 5% 1608 R/TP
		R747	0RJ4701D677	4.7K OHM 1/10 W 5% 1608 R/TP
		R769	0RJ0000D677	0 OHM 1/10 W 5% 1608 R/TP
		R775	0RJ0682D677	68 OHM 1/10 W 5% 1608 R/TP
		R779	0RJ0682D677	68 OHM 1/10 W 5% 1608 R/TP
		R780	0RJ2001D677	2K OHM 1/10 W 5% 1608 R/TP
		R781	0RJ2001D677	2K OHM 1/10 W 5% 1608 R/TP
		R782	0RJ0471D677	4.7 OHM 1/10 W 5% 1608 R/TP
		R803	0RJ0000D677	0 OHM 1/10 W 5% 1608 R/TP
		R805	0RJ1002D677	10K OHM 1/10 W 5% 1608 R/TP-L1750S
		R806	0RJ3900D677	390 OHM 1/10 W 5% 1608 R/TP-L1750S
		R807	0RJ3900D677	390 OHM 1/10 W 5% 1608 R/TP-L1750S
		R809	0RJ3900D677	390 OHM 1/10 W 5% 1608 R/TP-L1750S
		R810	0RJ3900D677	390 OHM 1/10 W 5% 1608 R/TP-L1750S
		R811	0RJ2202D677	22K OHM 1/10 W 5% 1608 R/TP-L1950S
		R812	0RJ5600D677	560 OHM 1/10 W 5% 1608 R/TP-L1950S
		R813	0RJ0472D677	47 OHM 1/10 W 5% 1608 R/TP
		R814	0RJ0472D677	47 OHM 1/10 W 5% 1608 R/TP
		R815	0RJ0472D677	47 OHM 1/10 W 5% 1608 R/TP
		R816	0RJ0472D677	47 OHM 1/10 W 5% 1608 R/TP
		R817	0RJ0472D677	47 OHM 1/10 W 5% 1608 R/TP
		R818	0RJ0472D677	47 OHM 1/10 W 5% 1608 R/TP
		R819	0RJ0472D677	47 OHM 1/10 W 5% 1608 R/TP
		R820	0RJ0472D677	47 OHM 1/10 W 5% 1608 R/TP

DATE: 2004. 12. 17.				
*S	*AL	LOC. NO.	PART NO.	DESCRIPTION / SPECIFICATION
		R821	0RJ0472D677	47 OHM 1/10 W 5% 1608 R/TP
		R822	0RJ0472D677	47 OHM 1/10 W 5% 1608 R/TP
		R823	0RJ0000D677	0 OHM 1/10 W 5% 1608 R/TP
		R824	0RJ0000D677	0 OHM 1/10 W 5% 1608 R/TP
OTHERS				
		X501	6212AA2004A	HC-49U TXC 12.0MHZ +/- 30 PP
CONTROL BOARD				
		C1	0CK104CK56A	0.1UF 1608 50V 10% R/TP X7R
		C2	0CK104CK56A	0.1UF 1608 50V 10% R/TP X7R
		LED1	0DLLT0208AA	LITE ON LIT-CT-C155KGJSKT R/TP
		R1	0RJ4701D677	4.7K OHM 1/10 W 5% 1608 R/TP
		R2	0RJ4701D677	4.7K OHM 1/10 W 5% 1608 R/TP
		R3	0RJ2001D677	2K OHM 1/10 W 5% 1608 R/TP
		R4	0RJ2001D677	2K OHM 1/10 W 5% 1608 R/TP
		R5	0RJ4701D677	4.7K OHM 1/10 W 5% 1608 R/TP
		SW1	6600TR1002A	SKQGACE010 J-ALPS NON 12V 50
		SW2	6600TR1002A	SKQGACE010 J-ALPS NON 12V 50
		SW3	6600TR1002A	SKQGACE010 J-ALPS NON 12V 50
		SW4	6600TR1002A	SKQGACE010 J-ALPS NON 12V 50
		SW5	6600TR1002A	SKQGACE010 J-ALPS NON 12V 50
		ZD1	0DZ560009GB	"BZT52C5V6S-(F),LF DIODES R/T"
		ZD2	0DZ560009GB	"BZT52C5V6S-(F),LF DIODES R/T"

3. POWER

3 POWER

L1750S/L1950S

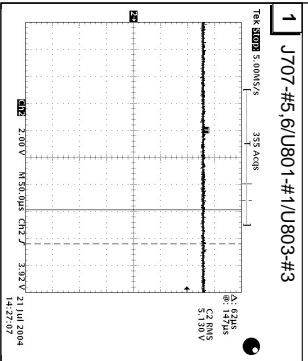
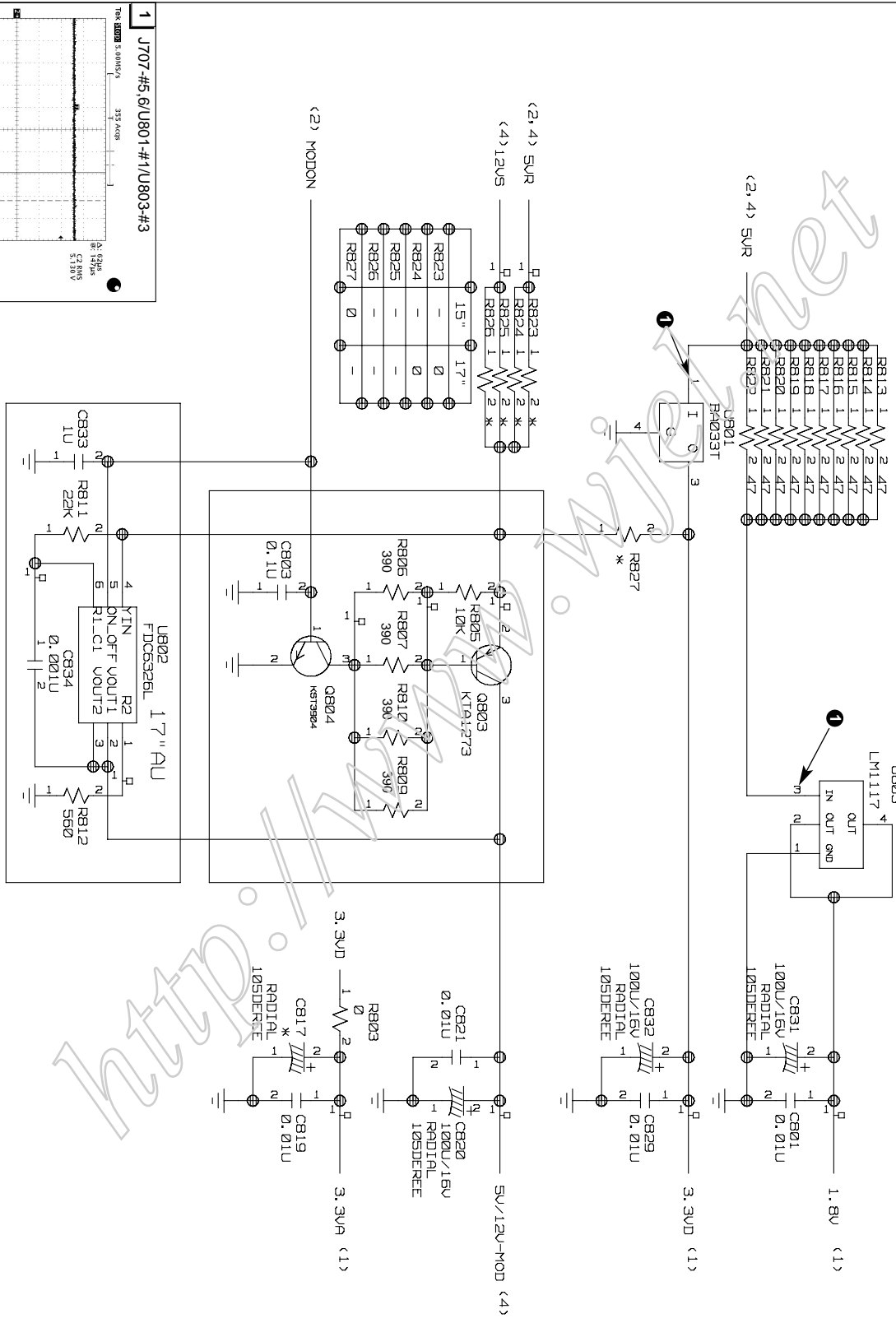

4. CONNECTOR & JACKS

4 L1750S/L1950S CONNECTOR & JACKS

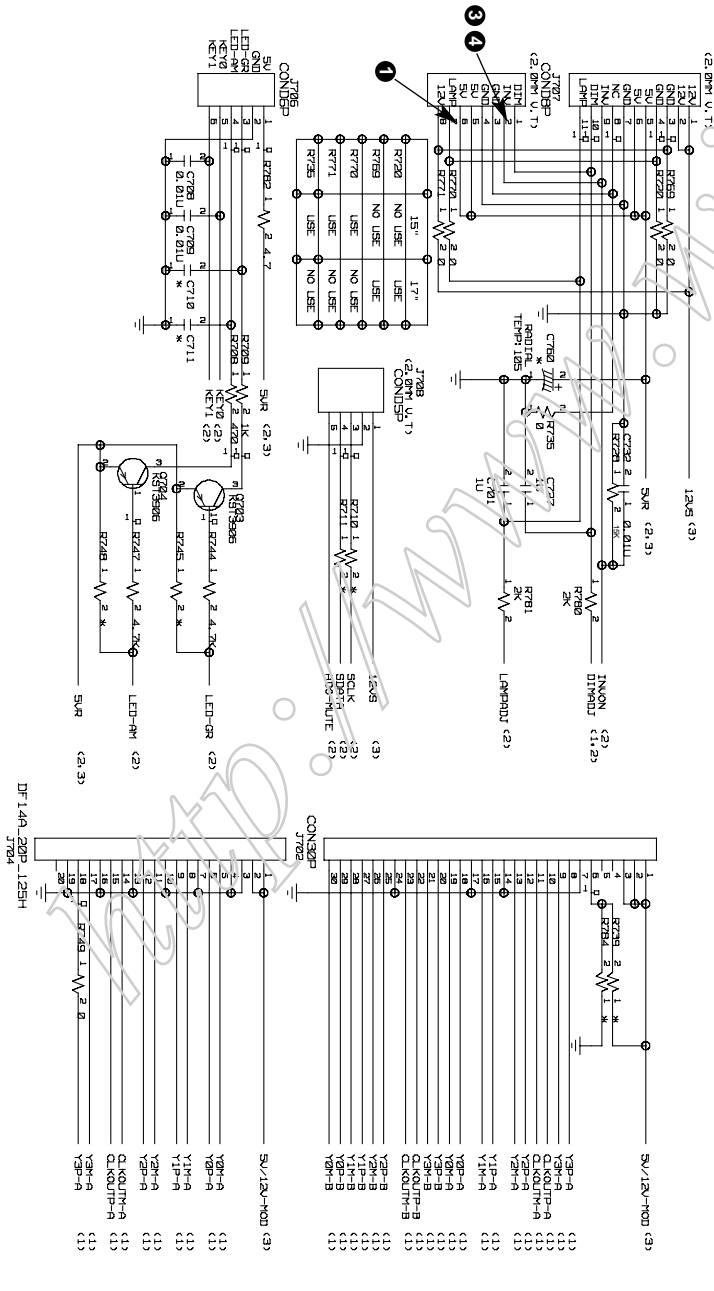
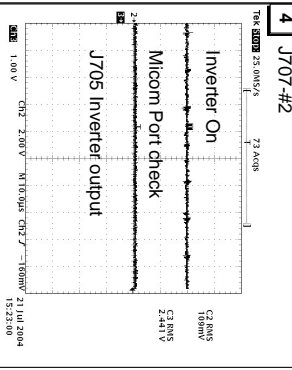
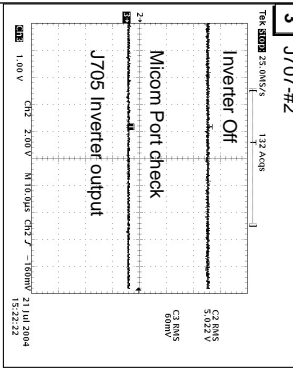
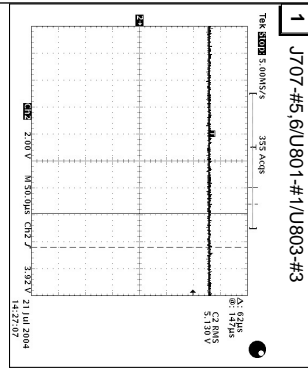
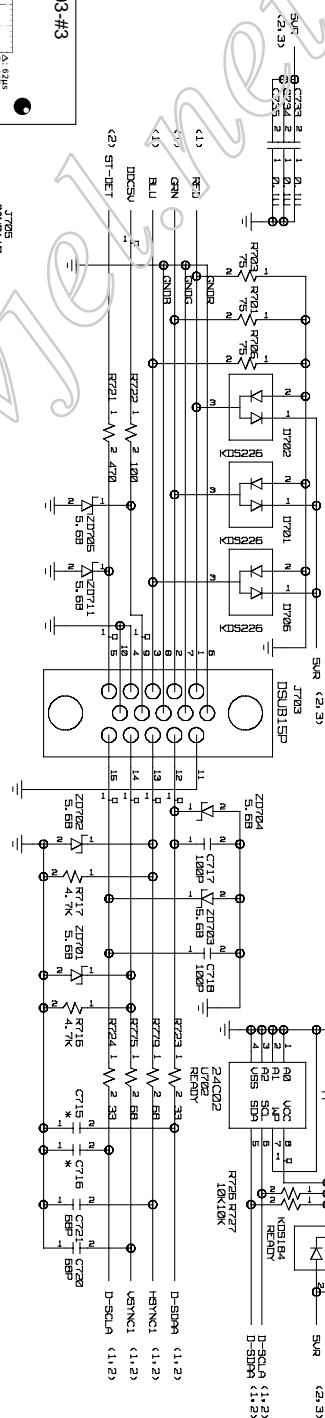



P/NO : 3828TSL096P

Dec. 2004
Printed in Korea

<http://www.wjel.net>