

# Industrial Computing

## Products and Services

Panel PC's



Industrial PC's



SBC's



Electronic Design



Industrial Displays

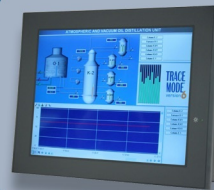

Embedding the future



### Why Choose DSL?

- ✓ Lifetime technical support
- ✓ Fully customisable products
- ✓ Product branding (bezel colours + company logos)
- ✓ Free pre-installation of OS and your software



### Our Services

- ✓ Electronic Design
- ✓ Production Management
- ✓ Assembly and test
- ✓ Bespoke BIOS creation



[sales@dsl-ltd.co.uk](mailto:sales@dsl-ltd.co.uk)

or call us on +44 (0)1462 675530





# ACS-2675C Box PC User Manual

**Release Date**

**Revision**

Dec. 2011

V1.0

©2011 Aplex Technology, Inc.

All Rights Reserved.

Published in Taiwan

**Aplex Technology, Inc.**

15F-1, No.186, Jian Yi Road, Zhonghe District, New Taipei City 235, Taiwan

Tel: 886-2-82262881 Fax: 886-2-82262883 E-mail: [aplex@aplex.com.tw](mailto:aplex@aplex.com.tw) URL: [www.aplex.com.tw](http://www.aplex.com.tw)

# Warning!

---

This equipment generates, uses and can radiate radio frequency energy and if not installed and used in accordance with the instructions manual, it may cause interference to radio communications. It has been tested and found to comply with the limits for a Class A computing device pursuant to FCC Rules, which are designed to provide reasonable protection against such interference when operated in a commercial environment. Operation of this equipment in a residential area is likely to cause interference in which case the user at his own expense will be required to take whatever measures may be required to correct the interference.

Electric Shock Hazard – Do not operate the machine with its back cover removed. There are dangerous high voltages inside.

## Disclaimer

**This information in this document is subject to change without notice. In no event shall Aplex Technology Inc. be liable for damages of any kind, whether incidental or consequential, arising from either the use or misuse of information in this document or in any related materials.**

# Packing List

Accessories (as ticked) included in this package are:

- AC power cable
- Driver & manual CD disc
- Other. \_\_\_\_\_ (please specify)

## Safety Precautions

Follow the messages below to prevent your systems from damage:

- ◆ Avoid your system from static electricity on all occasions.
- ◆ Prevent electric shock. Don't touch any components of this card when the card is power-on. Always disconnect power when the system is not in use.
- ◆ Disconnect power when you change any hardware devices. For instance, when you connect a jumper or install any cards, a surge of power may damage the electronic components or the whole system.

# Table of Contents

---

Warning!.....	2
Disclaimer.....	2
Packing List.....	3
Safety Precautions.....	3

## **Chapter 1** **Getting Started**

---

1.1 Specifications.....	6
1.2 Dimensions.....	7
1.3 Installation of HDD.....	8
1.4 Installation of PCI Addon.....	9
1.5 Brief Description.....	10

## **Chapter 2** **Hardware**

---

2.1 Mainboard.....	11
2.2 Installations.....	12
2.2.1 Jumpers Setting and Connectors.....	12

## **Chapter 3** **BIOS Setup**

---

3.1 Operations after POST Screen.....	32
3.2 BIOS SETUP UTILITY.....	33
3.3 System Overview.....	33
3.4 Advanced Settings.....	34
3.5 Advanced PCI/PnP Settings.....	43
3.6 Boot Settings.....	46
3.7 Security Settings.....	48
3.8 Advanced Chipset Settings.....	49
3.9 Exit Options.....	56

## **Chapter 4** **Installation of Drivers**

---

4.1 Intel Chipset Driver.....	59
4.2 Intel Graphics Media Accelerator Driver.....	62
4.3 Intel 82574L LAN Device Driver.....	66
4.4 Realtek ALC662 HD Audio Driver Installation.....	69
4.5 Microsoft .NET Framework 3.5 Service Installation.....	71

## Figures

---

Figure 1.1: ACS-2675C Dimensions.....	7
Figure 1.2: Front View .....	10
Figure 1.3: Rear View.....	10
Figure 2.1: Mainboard Dimensions.....	11
Figure 2.2: Jumpers and Connectors Location_ Board Top.....	12
Figure 2.3: Jumpers and Connectors Location_ Board Bottom.....	13

## 1.1 Specifications

Specs	ACS-2675C
CPU	Intel Socket P Core 2 Duo 45nm Processor, up to P8600 2.4GHz FSB1066/800/667MHz
System Chipset	Intel GM45 + Intel ICH9M-E
System Memory	2 x 204 Pin DDR3 SO-DIMM slot, up to 8GB 800/1066 SDRAM
External I/O Port	Rear Side: <ul style="list-style-type: none"> <li>● 2 x DB-9 RS-232 COM1/2</li> <li>● 1 x DB-15 VGA</li> <li>● 1 x HDMI</li> <li>● 2 x RJ45 GbE LAN</li> <li>● 4 x USB 2.0</li> <li>● 1 x Mic-in, Line-Out</li> <li>● 1 x DC Power input 3 Pin terminal block connector</li> <li>● 1 x Additional terminal block for switch</li> <li>● 2 x LED Indication</li> </ul> Front Side: <ul style="list-style-type: none"> <li>● 1 x Power on/off</li> <li>● 1 x 5 Pin terminal block for GPIO (option)</li> <li>● 1 x RS-232 COM4</li> <li>● 1 x RS-422/485 COM3, default RS-485</li> <li>● 2 x USB 2.0</li> </ul>
Expansion Slots	2 x PCI / 1 x PCI + 1 x PCIe x1 for option
Storage	<ul style="list-style-type: none"> <li>● 2 x 2.5" SATA HDD Space</li> <li>● 1 x CF Slot (External)</li> </ul>
Power Supply	DC 9~32V
Construction / Color	Aluminum Molding Heat sink + Steel Chassis / Silver
Mounting	Wall mount
Dimensions	268(W)x195(H)x125.7(D) mm
Operating Temperature	0~50 °C
Storage Temperature	-20~60 °C
Storage Humidity	10%~90%@ 40°C, non-condensing
Certificate	CE / FCC Class A

## 1.2 Dimensions

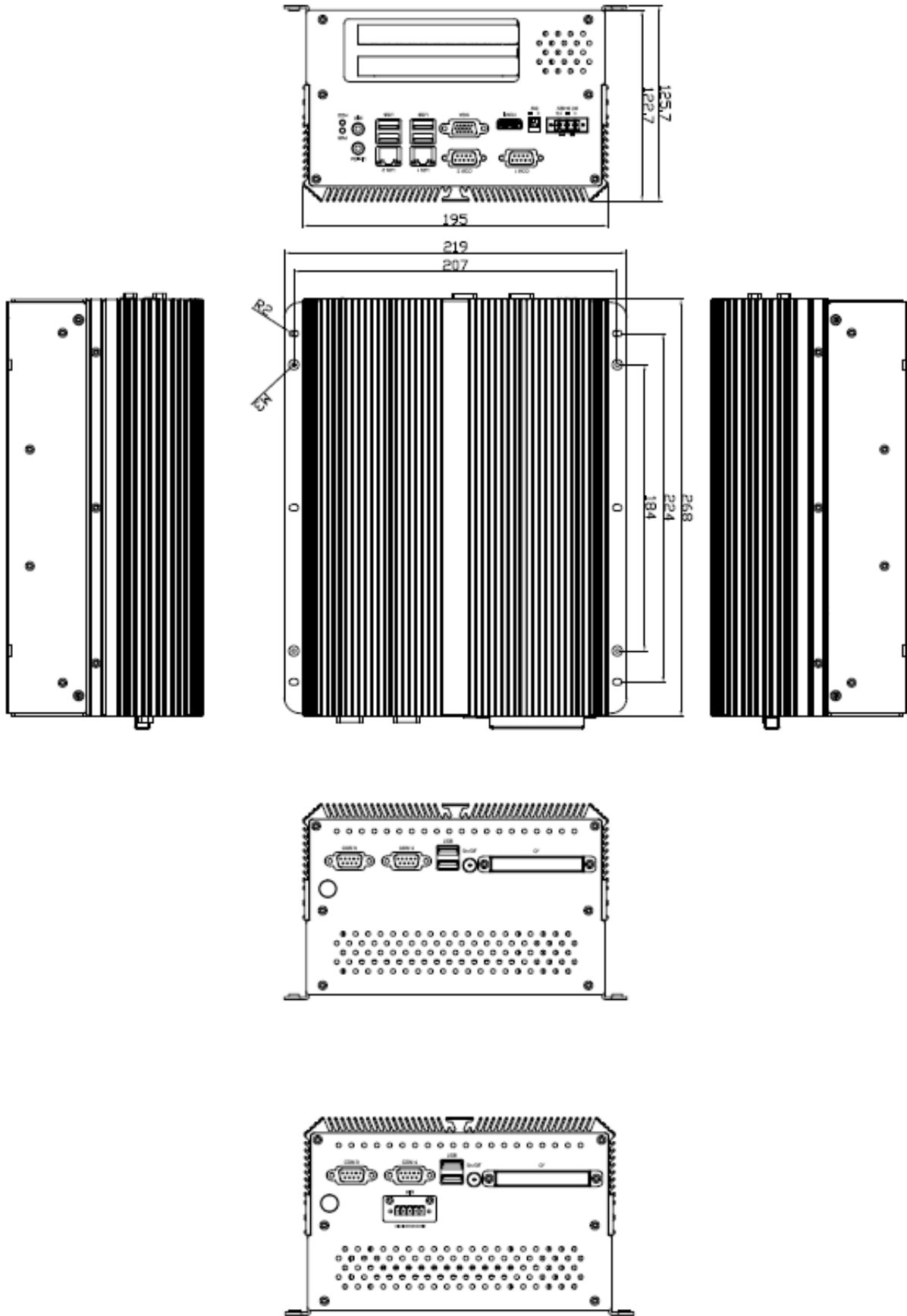

**Figure 1.1: Dimensions of the ACS-2675C**



## 1.3 Installation of HDD

### Step 1

There are 9 screws to deal with when enclosing or removing the chassis.

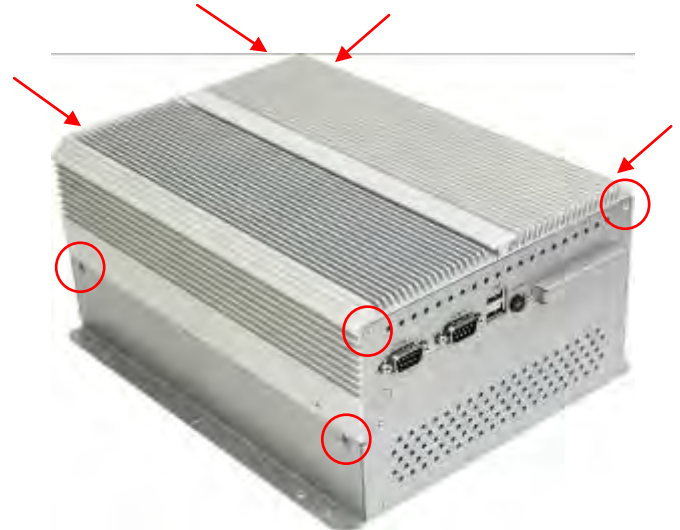

### Step 2

Get the HDD screwed to the bracket with the four screws as shown by the arrows in the picture.

Connect the cable to the HDD as shown in the picture, making sure the red stripe of the cable is rightly positioned



### Step 3

That's how it should look after it has been installed.

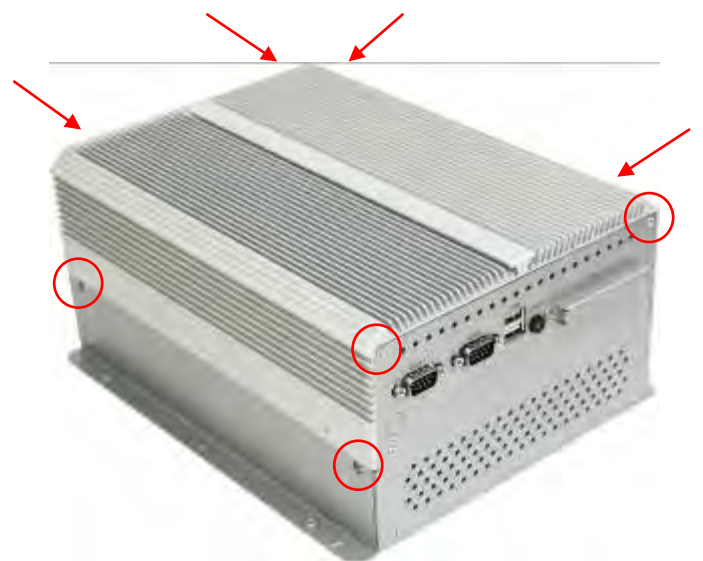

## 1.4 Installation of PCI Addon

### Step 1

There are 2 screws to deal with when enclosing or removing the chassis.

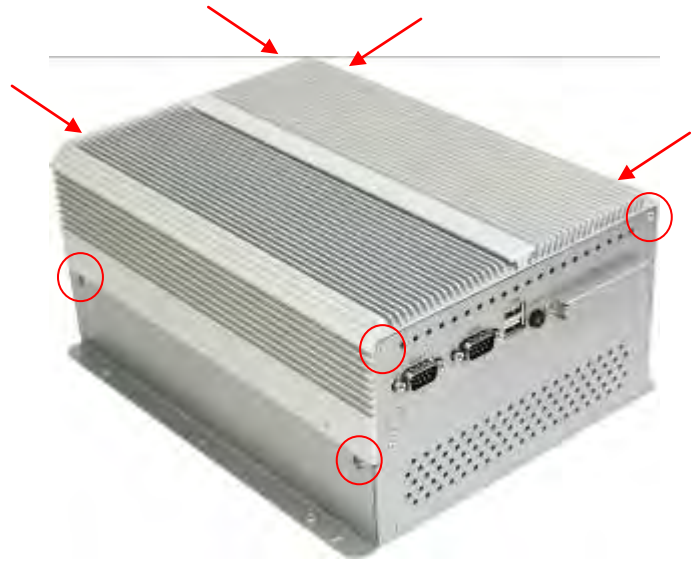

### Step 2

Now slide the addon into the PCI slot, making sure the golden part faces the slot. When the part that is interfaced together come into the right contact, slightly push the addon into the rail of the slot.

After sliding the addon into the PCI expansion slot, get the one screws as circled tightened to finish the connection.



### Step 3

To finish the job, just fasten the 2 screws as shown in the picture.

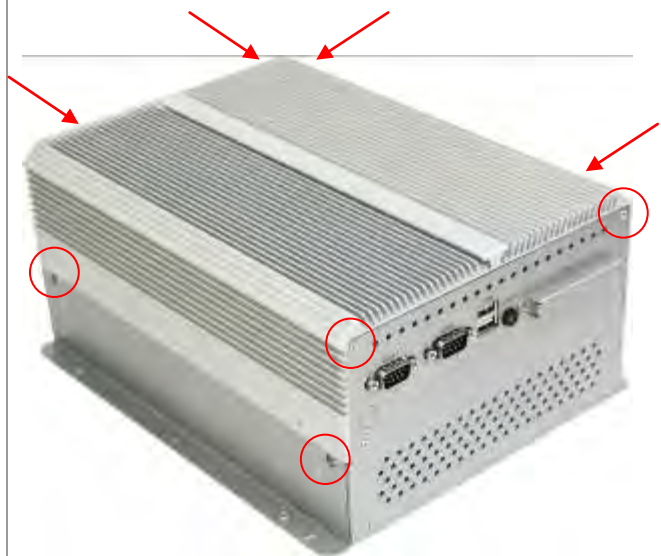

## 1.5 Brief Description of the ACS-2675C

The ACS-2675C is a Fan-less High-efficiency Thermal Solution and ultra-compact standalone Box PC, powered by an Intel Core 2 Duo with 45nm, up to P8600 2.4GHz, and supporting 6 x USB 2.0 ports, 4 x COM Ports, 1 x VGA, 1 x HDMI, support PCI or PCIe Expansion, 2 x SATA HDD space, 1 x external CF slot, 9-32V wide-ranging power input etc. It is ideal for kiosks, POS systems, airport terminal controllers, digital entertainments, etc. and running factory operations from small visual interface and maintenance applications to large control process applications. The ACS-2675C works very well along with any of our Display Monitor series and it absolutely can provide an easy way to perform control and field maintenance.

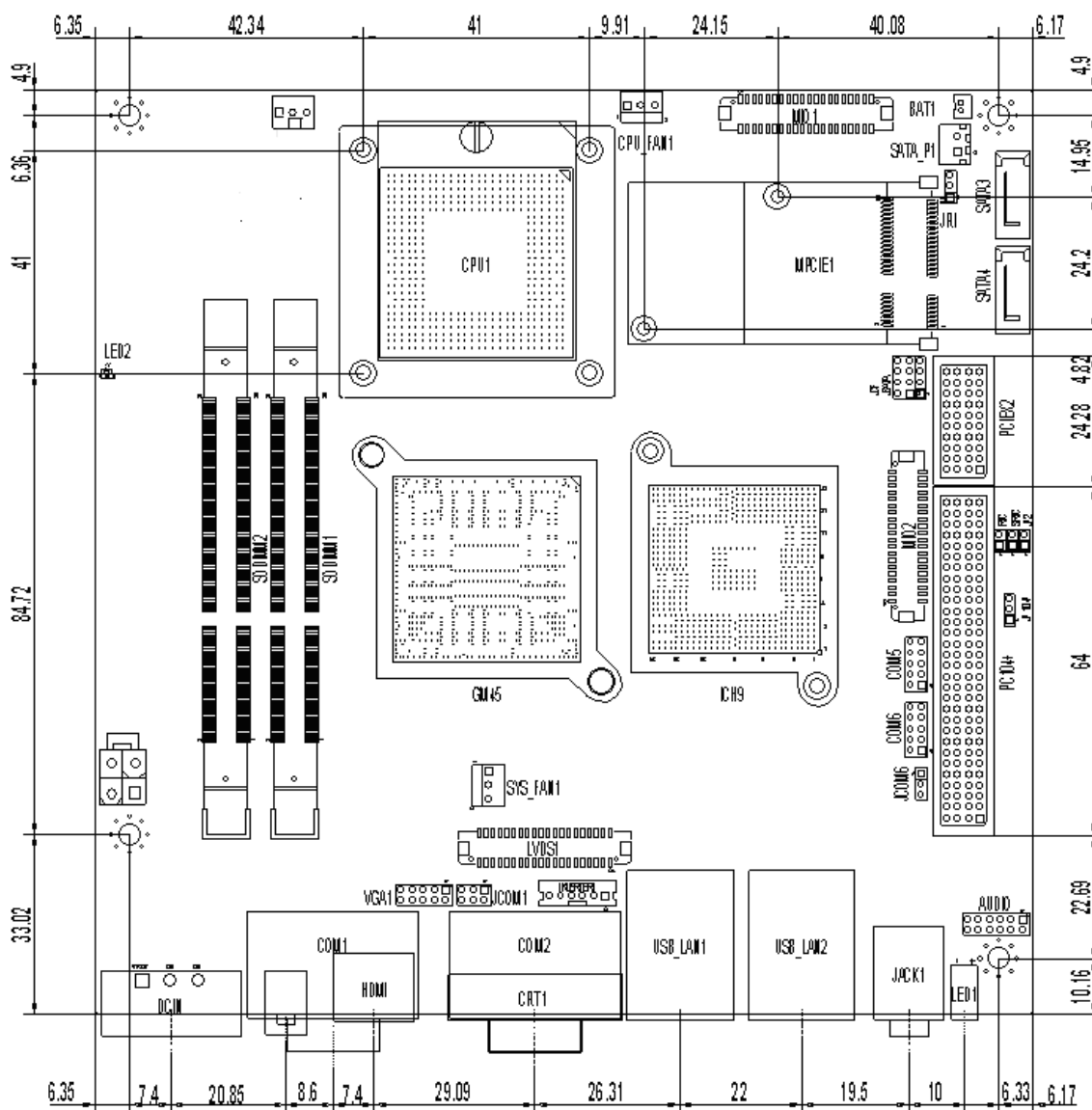

**Figure 1.2: Front View of ACS-2675C**



**Figure 1.3: Rear View of ACS-2675C**

## 2.1 Mainboard



**Figure 2.1: Mainboard Dimensions**

## 2.2 Installations

ASB-M801 is a Mini-ITX industrial motherboard developed on the basis of Intel GM45 and ICH9M, which provides abundant peripheral interfaces to meet the needs of different customers. Also, it features dual 1000M LAN port, 6-COM port and one Mini PCIE configuration. To satisfy the special needs of high-end customers, PC104+ port (capable of adjusting IO voltage) richer extension functions. The product is widely used in various sectors of industrial control.

### 2.2.1 Jumpers Setting and Connectors

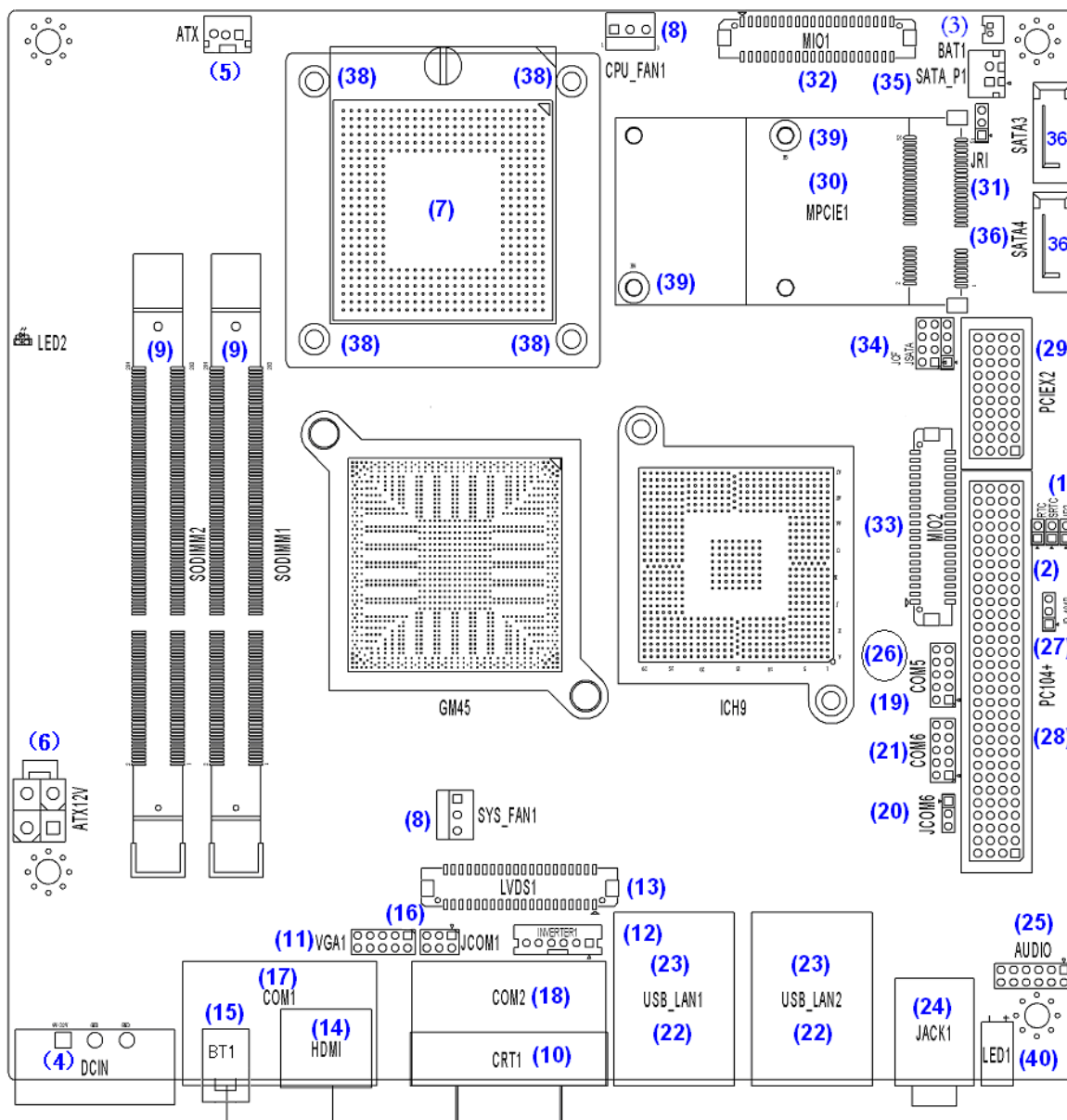
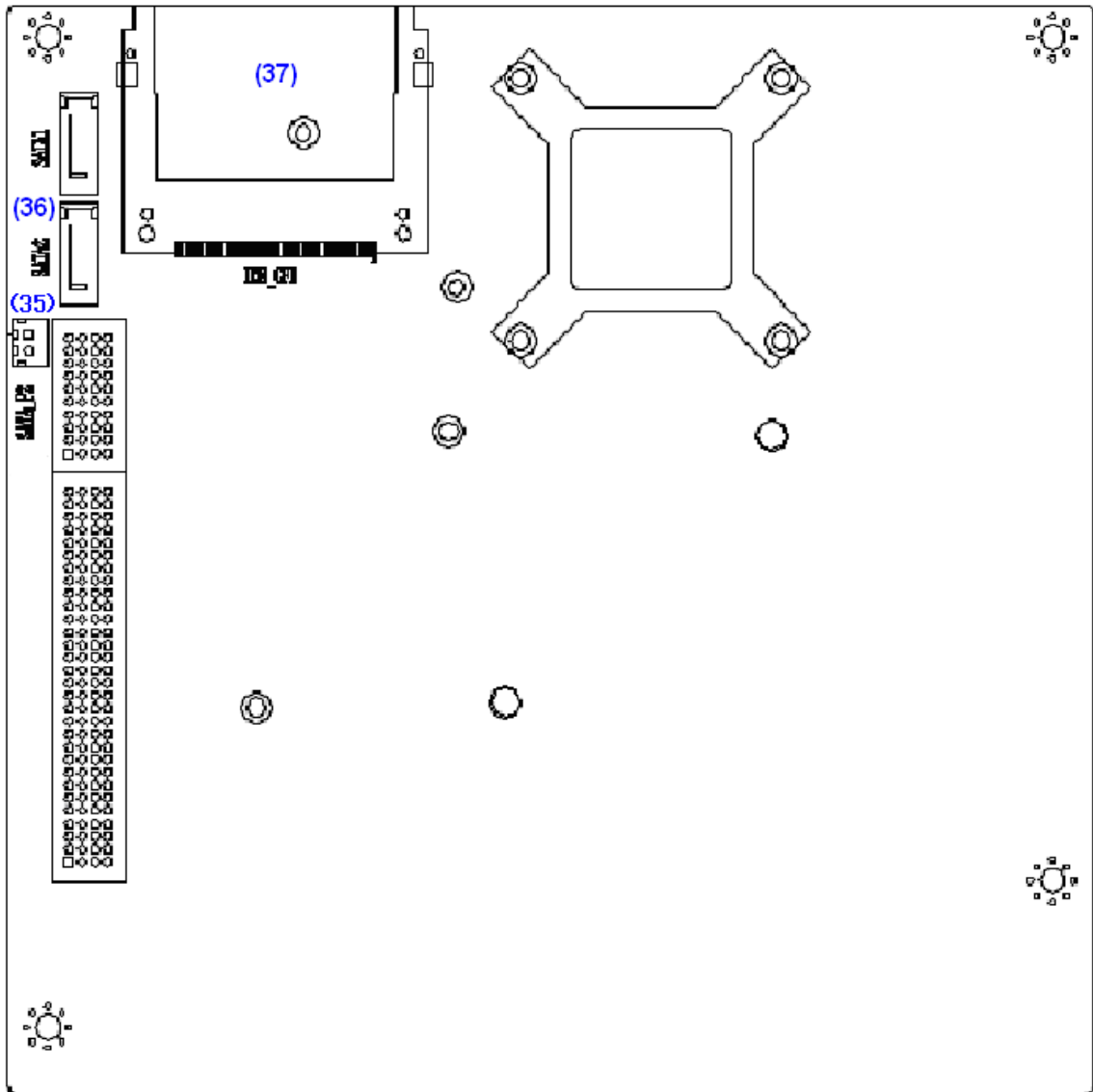

Figure 2.2: Jumpers and Connectors Location\_ Board Top



**Figure 2.3: Jumpers and Connectors Location\_ Board Bottom**

**1. JP2:**

(2.0mm Pitch 1X2 Pin Header),ATX Power and Auto Power on jumper setting.

JP2	Mode
Open	ATX Power
<b>Close</b>	<b>Auto Power on</b> (Default)

**2. RTC/SRTC:**

(2.0mm Pitch 1X2 Pin Header)CMOS clear jumper, CMOS clear operation will permanently reset old BIOS settings to factory defaults.

RTC/SRTC	CMOS
----------	------

Open	NORMAL (Default)
Close 1-2	Clear CMOS



### Procedures of CMOS clear:

- a) Turn off the system and unplug the power cord from the power outlet.
- b) To clear the CMOS settings, use the jumper cap to close pins1 and 2 for about 3 seconds then reinstall the jumper clip back to pins open.
- c) Power on the system again.
- d) When entering the POST screen, press the <F1> or <DEL> key to enter CMOS Setup Utility to load optimal defaults.
- e) After the above operations, save changes and exit BIOS Setup.

### 3. BAT1 :

(1.25mm Pitch 1X2 box Pin Header) 3.0V Li battery is embedded to provide power for CMOS.

Pin#	Signal Name
Pin1	VBAT
PIN2	Ground

### 4. DCIN:

(5.08mm Pitch 1x3 Pin Connector),DC9V ~ DC32V System power input connector ◦



Pin#	Power Input
Pin1	DC+9V~32 V
Pin2	Ground
Pin3	Ground

Power Mode	Location (5.4.4.)	Location (5.4.5.)	Location (5.4.6.) <b>ATX</b>
------------	----------------------	----------------------	---------------------------------

	<b>DCIN</b>	<b>ATX12V</b>	
<b>AT</b> (Default)	<b>input</b> DC9~32V	<b>output</b> DC 12V	<b>NC</b>

**5. ATX12V:**

(2x2 Pin Connector),DC12V System power **output** connector.

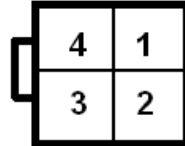

Pin#	Power <b>output</b>
Pin1	Ground
Pin2	Ground
Pin3	DC+12V
Pin4	DC+12V

**6. ATX (option):**

(2.0mm Pitch 1X3 box Pin Header), connect PSON and 5VSB and Ground signal,support ATX Power model. **Reserved.**

Pin#	Signal Name
Pin1	ATX PSON
PIN2	ATX Ground
PIN3	ATX 5VSB

**7. CPU1:**

(Socket P), installing the CPU Socket.

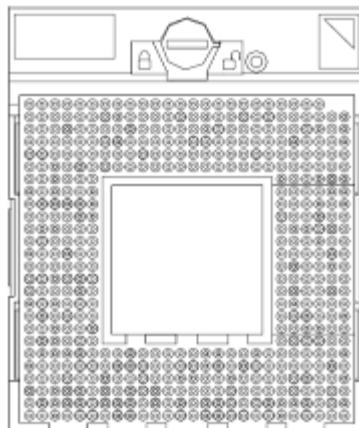



## 8. CPU\_FAN1/SYS\_FAN1:

(2.54mm Pitch 1x3 Pin Header), Fan connector, cooling fans can be connected directly for use. You may set the rotation condition of cooling fan in menu of BIOS CMOS Setup.



Pin#	Signal Name
1	Ground
2	VCC
3	Rotation detection



Note:

Output power of cooling fan must be limited under 5W.

## 9. SODIMM1/SODIMM2:

(SO-DIMM 204Pin socket), DDRIII memory socket, the socket is located at the Top of the board and supports 204Pin 1.5V DDRIII 800/1066MHz FSB SO-DIMM memory module up to 8GB.

## 10. CRT1:

(CRT DB15 Connector ), Video Graphic Array Port, provide high-quality video output. **they can not work at the same time for CRT1 and VGA1.**

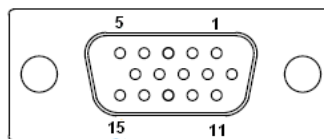

## 11. VGA1:

(CRT 2.0mm Pitch 2X5 Pin Header), Video Graphic Array Port, Provide 2x5Pin cable to VGA Port, **they can not work at the same time for CRT and VGA1.**

Signal Name	Pin#	Pin#	Signal Name
CRT_RED	1	2	Ground
CRT_GREEN	3	4	Ground
CRT_BLUE	5	6	VGA_EN
CRT_H_SYN	7	8	CRT_DDCCDAT

C			A
CRT_V_SYNC	9	10	CRT_DDCCLK

## 12. INVERTER1:

(2.0mm Pitch 1x6 box Pin Header), Backlight control connector for LVDS1.

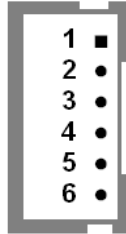

Pin#	Signal Name
1	+DC12V
2	+DC12V
3	Ground
4	Ground
5	BKLT_EN
6	BKLT_CTRL



Note:

Pin6 is backlight control signal, support DC or PWM mode, mode select at BIOS CMOS menu.

## 13. LVDS1:

(1.25mm Pitch 2x20 Connector), For 18/24-bit LVDS output connector, Fully supported by Intel GM45 chipset, the interface features dual channel 18/24-bit output.

Signal Name	Pin#	Pin#	Signal Name
VDD5	2	1	VDD5
Ground	4	3	Ground
VDD33	6	5	VDD33
LB_D0_N	8	7	LA_D0_N
LB_D0_P	10	9	LA_D0_P
Ground	12	11	Ground
LB_D1_N	14	13	LA_D1_N
LA_D1_P	16	15	LA_D1_P
Ground	18	17	Ground
LB_D2_N	20	19	LA_D2_N

LB_D2_P	22	21	LA_D2_P
Ground	24	23	Ground
LB_CLK_N	26	25	LA_CLK_N
LB_CLK_P	28	27	LA_CLK_P
Ground	30	29	Ground
DS_DDC_DATA	32	31	LVDS_DOC_CLK
Ground	34	33	Ground
LB_D3_N	36	35	LA_D3_N
LB_D3_P	38	37	LA_D3_P
NC	40	39	NC

**14. HDMI:**

(HDMI 19P Connector), High Definition Multimedia Interface connector.

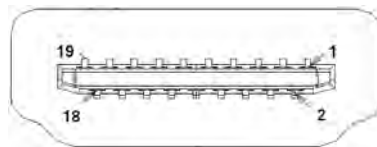

**15. BT1:**

**POWER on/off Button**, They are used to connect power switch button. The two pins are disconnected under normal condition. You may short them temporarily to realize system startup & shutdown or awaken the system from sleep state.

**16. JCOM1:**

(2.0mm Pitch 2x3 Pin Header), COM1 jumper setting, pin 1~6 are used to select signal out of pin 9 of COM1 port.

JP3 Pin#	Function
<b>Close 1-2</b>	<b>COM1 RI (Ring Indicator) (default)</b>
Close 3-4	COM1 Pin9=+5V (option)
Close 5-6	COM1 Pin9=+12V (option)

**17. COM1:**

**(Type DB9)**,Rear serial port, standard DB9 Male serial port is provided to make a direct connection to serial devices. COM1 port is controlled by pins No.1~6 of JCOM1,select output Signal RI or 5V or 12v, For details, please refer to description of JCOM1.

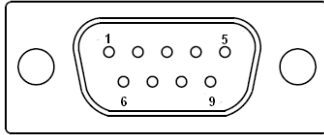

Pin#	Signal Name
1	DCD# (Data Carrier Detect)
2	RXD (Received Data)
3	TXD (Transmit Data)
4	DTR (Data Terminal Ready)
5	Ground
6	DSR (Data Set Ready)
7	RTS (Request To Send)
8	CTS (Clear To Send)
9	<b>JCOM1 select Setting</b>

**18. COM2:**

(Type DB9),Rear serial port, standard DB9 Male serial port is provided to make a direct connection to serial devices.

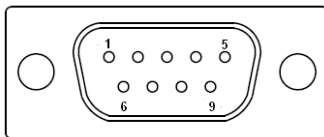

Pin#	Signal Name
1	DCD# (Data Carrier Detect)
2	RXD (Received Data)
3	TXD (Transmit Data)
4	DTR (Data Terminal Ready)
5	Ground
6	DSR (Data Set Ready)
7	RTS (Request To Send)
8	CTS (Clear To Send)
9	RI (Ring Indicator)

**19. COM5:**

(2.0mm Pitch 2X5 Pin Header),COM5 Port, standard RS232 ports are provided. They can be used directly via COM cable connection.

Signal Name	Pin#	Pin#	Signal Name

DCD	1	2	RXD
TXD	3	4	DTR
Ground	5	6	DSR
RTS	7	8	CTS
RI	9	10	NC

**20. JCOM6:**

(2.0mm Pitch 1x3 Pin Header) COM6 setting jumper, pin 1~3 are used to select signal out of pin 10 of COM6 port.

JP1 Pin#	Function
Close 1-2	<b>COM5 Pin10=+5V (default)</b>
Close 2-3	COM5 Pin10=+12V (option)

**21. COM6:**

(2.0mm Pitch 2X5 Pin Header), COM6 Port, standard RS232 ports are provided. They can be used directly via COM cable connection. COM6 port is controlled by pins No. 1~3 of JCOM6, select output Signal 5V or 12v, For details, please refer to description of **JCOM6**.

Signal Name	Pin#	Pin#	Signal Name
DCD	1	2	RXD
TXD	3	4	DTR
Ground	5	6	DSR
RTS	7	8	CTS
RI	9	<b>10</b>	<b>JCOM6 select Setting</b>

**22. USB4/USB5/USB6/USB7:**

(Double stack USB type A), Rear USB connector, it provides up to 4 USB2.0 ports, speed up to 480Mb/s.

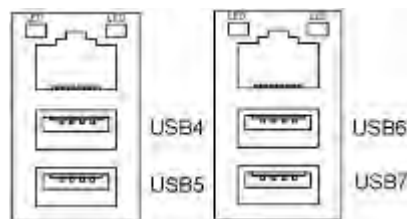

**23. LAN1/LAN2:**

(RJ45 Connector) Rear LAN port, Two standard 10/100/1000M RJ-45 Ethernet ports are provided. Used Intel 82574L chipset, LINK LED (green) and ACTIVE LED (yellow)

respectively located at the left-hand and right-hand side of the Ethernet port indicate the activity and transmission state of LAN.

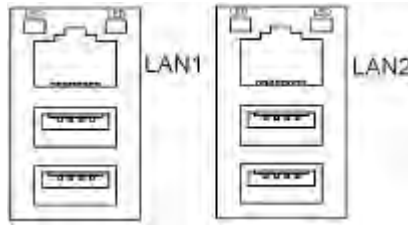

**24. JACK1:**

(Diameter 3.5mm Double stack Jack), HD Audio port, An onboard Realtek ALC662 codec is used to provide high quality audio I/O ports. Line Out can be connected to a headphone or amplifier, MIC is the port for microphone input audio.

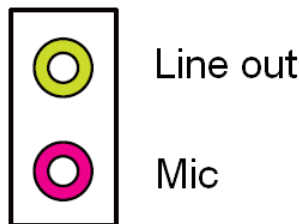

**25. AUDIO:**

(2.0mm Pitch 2X6 Pin Header), Front Audio, An onboard Realtek ALC662 codec is used to provide high-quality audio I/O ports. Line Out can be connected to a headphone or amplifier. Line In is used for the connection of external audio source via a Line in cable. MIC is the port for microphone input audio.

Signal Name	Pin#	Pin#	Signal Name
FRONT_OUTP-L	1	2	FRONT_OUTP_R
FRONT_OUTN_L	3	4	FRONT_OUTN_R
FRONT_JD	5	6	LINE1_JD
LINE_IN_L	7	8	LINE1_IN_R
MIC2_IN_L	9	10	MIC2_IN_R
Ground	11	12	MIC2_JD

**26. BZ:**

Onboard buzzer.

**27. JP\_104P:**

(2.0mm Pitch 1X3 Pin Header) PC104+ port voltage selection jumper, select voltage

for PCI-104 Plus devices. **The default for this jumper is “all open”, meaning the user must select the voltage to be used.**

JP_104P Pin#	PC104+ VIO Voltage
<b>All Open</b>	<b>Default</b>
Close 1-2	+3.3V PCI Card
Close 2-3	+5V PCI Card

**28. PC104+ (option):**

(4x30 Pin), PC104 plus connector, it conforms to standard PC104+ specification. Can expand support four PCI devices.

ASB-M801T/ET : PC104+ connector in the top.

ASB-M801B/EB : PC104+ connector in the Bottom.

**29. PCIEX2 (option):**

(4x10 Pin), PCIe bus connector, it conforms to standard PCI Express x1 specification.

Can expand support **two** PCIe devices.

ASB-M801T/ET : PCIEX2 connector in the top.

ASB-M801B/EB : PCIEX2 connector in the Bottom.

MODEL	PC104+ / PCIEX2
ASB-M801T	Top
ASB-M801ET	Top
ASB-M801B	Bottom
ASB-M801EB	Bottom

**30. MPCIE1:**

(Socket 52Pin), mini PCIe socket, it is located at the top, it supports mini PCIe devices with USB2.0, SMBUS and PCIe signal. MPCle card size is 30x30mm or 30x50.95mm.

**31. JRI:**

(2.0mm Pitch 1X3 Pin Header), Wake up setting jumper. pin 1~2 are used to select signal for COM4 Wake up, pin 2~3 are used to select signal for PCI devices Wake up,

JRI Pin#	Function
Close 1-2	PCI_PME for COM4
Close 2-3	PCI-PME for PCI

**32. MIO1:**

(1.25mm Pitch 2x20 Connector), For expand output connector, It provides two RS232

ports or one RS485 port, three USB ports, one power led, one power button, via a dedicated cable connected to **TB-522 MIO1**.

Function	Signal Name	Pin#	Pin#	Signal Name	Function
COM3	422RX+	1	2	485+ / 422TX+	COM3 RS422 or RS485
	422RX-	3	4	485- / 422TX-	
	Ground	5	6	NC	
	NC	7	8	NC	
	NC	9	10	5V_S5	
COM4	DCD4-	11	12	RXD4	COM4
	TXD4	13	14	DTR4-	
	Ground	15	16	DSR4-	
	RTS4-	17	18	CTS4-	
	RI4-	19	20	5V_S5	
USB9	5V_USB_9	21	22	5V_USB_1011	USB10
	USB9_N	23	24	USB10_N	
	USB9_P	25	26	USB10_P	
	Ground	27	28	Ground	
	Ground	29	30	Ground	
USB11	5V_USB_1011	31	32	PWR_LED+	Power LED
	USB11_N	33	34	PWR_LED-	
	USB11_P	35	36	MIO_PSON	Power Button
	Ground	37	38	Ground	
	Ground	39	40	Ground	

### 33. MIO2:

(1.25mm Pitch 2x20 Connector), Front panel connector.

Function	Signal Name	Pin#	Pin#	Signal Name	Function
H_LED+	HDD_LED	1	2	PWR-LED	P_LED+
H_LED-	Ground	3	4	Ground	P_LED-
RESET-	Ground	5	6	MIO_PSON-	PSON+
RESET+	RESET	7	8	Ground	PSON-
BUZZER+	BUZZER+	9	10	BUZZER-	BUZZER-
GPIO_I N	GPIO_IN_1	11	12	GPIO_OUT_1	GPIO_OU T
	GPIO_IN_2	13	14	GPIO_OUT_2	
	GPIO_IN_3	15	16	GPIO_OUT_3	



	GPIO_IN_4	17	18	GPIO_OUT_4	
PS2_K/ B	Ground	19	20	5V_S5	PS2_Mouse
	PS2_KBDATA	21	22	PS2_MSDATA	
	PS2_KBCLK	23	24	PS2_MSCLK	
USB2	5V_USB_23	25	26	5V_USB_23	USB3
	USB2_N	27	28	USB3_N	
	USB2_P	29	30	USB3_P	
	Ground	31	32	Ground	
USB0	5V_USB_01	33	34	5V_USB_01	USB1
	USB0_N	35	36	USB1_N	
	USB0_P	37	38	USB1_P	
	Ground	39	40	Ground	

Pin1-3: **HDD LED**, They are used to connect hard disk activity LED. The LED blinks when the hard disk is reading or writing data.

Pin2-4: **POWER LED**, They are used to connect power LED. When the system is powered on or under S0/S1 state, the LED is normally on, when the system is under S4/S5 state, the LED is off.

Pin5-7: **RESET Button**, They are used to connect reset button. The two pins are disconnected under normal condition. You may short them temporarily to realize system reset.

Pin6-8: **POWER on/off Button**, They are used to connect power switch button. The two pins are disconnected under normal condition. You may short them temporarily to realize system startup & shutdown or awaken the system from sleep state.

Pin9-10: **BUZZER**, They are used to connect an external buzzer.

Pin11-18: **GPIO IN/GPIO OUT**, General-purpose input/output port, it provides a group of self-programming interfaces to customers for flexible use.

Pin19-24: **PS2 KB/MS**, PS/2 keyboard and mouse port, the port can be connected to PS/2 keyboard and mouse via a dedicated cable for direct used.

Pin25-40: **USB0/USB1/USB2/USB3**, Front USB connector, it provides 4 USB ports

via a dedicated USB cable, speed up to 480Mb/s.



**Note:**

When connecting LEDs and buzzer and GPIO and USB, pay special attention to the signal polarity. Make sure that the connector pins have a one-to-one correspondence with chassis wiring, or it may cause boot up failure.

**34. JCF/JSATA:**

(2.0mm Pitch 3x4 Pin Header), it provides selectable IDE\_CF1 or SATA4 signal output control.

Function	Jumper setting
SATA 4 (Default)	<p>JSATA</p>
IDE_CF 1 (option)	<p>JCF</p>

**35. SATA\_P1/SATA\_P2:**

(2.5mm Pitch 1x2 box Pin Header), Two onboard 5V output connectors are reserved to provide power for SATA devices.

Pin#	Signal Name
1	+DC5V
2	Ground



**Note:**

**Output current of the connector must not be above 1A.**

**36. SATA1/SATA2/SATA3/SATA4:**

(SATA 7P), SATA Connectors, Four SATA connectors are provided, with transfer speed

up to 3.0Gb/s.

(Option):

ASB-M801ET/EB: SATA1/SATA2/SATA3 drives supporting RAID 0 or RAID 1 function.

MODEL	SATA Color	RAID
ASB-M801T ASB-M801B	Black: SATA1/SATA2/SATA3/SATA4	No
ASB-M801ET ASB-M801EB	Blue: SATA1/SATA2/SATA3 Black: SATA4	Yes

**37. IDE\_CF1 (Option):**

(CF\_Card socket), it is located at the bottom of the board and serves as an insert interface for Type I and Type II Compact Flash card. The operating voltage of CF card can be set as 3.3V or 5V, **The default setting of the product is 3.3V.** Please refer to description of JCF/JSATA Jumper setting.

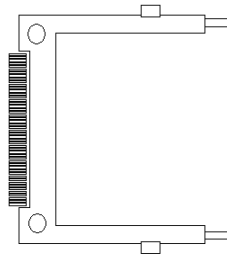

**38. CPU SCREW HOLES:**

CPU FAN SCREW HOLES, Four screw holes for fixed CPU Cooler assemble.

**39. H5/H6:**

MPCIE1 SCREW HOLES, H5 for mini PCIE card (30mmx30mm) assemble. H6 for mini PCIE card (30mmx50.95mm) assemble.

**40. LED1:**

LED STATUS. Green LED for Motherboard Standby Power Good status, Yellow LED for HDD status.

**41. TB-522 (Option):**

ASB-M801 I/O Card, via a dedicated cable connected to ASB-M801 MIO1.

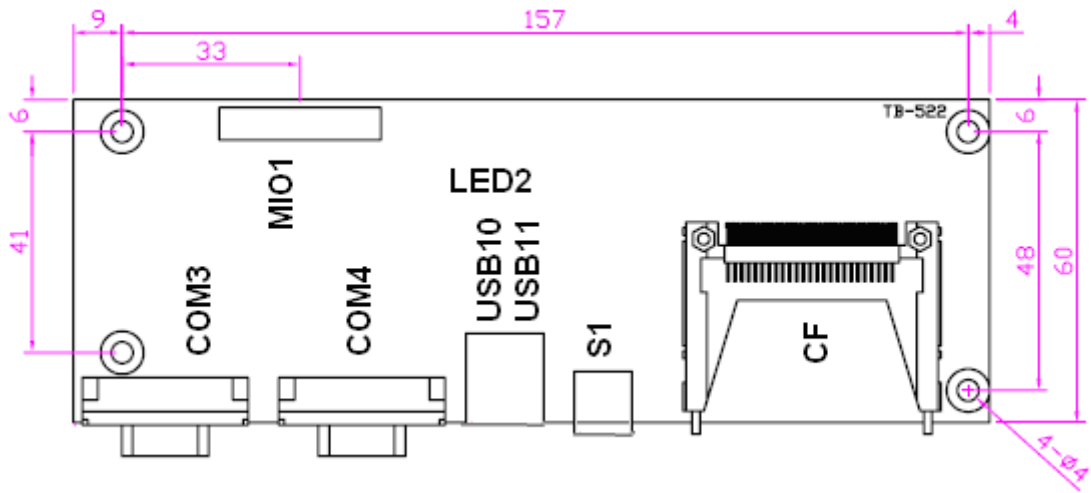

**LED2:**

POWER LED status.

**S1:**

**PWR BT: POWER on/off Button**, They are used to connect power switch button. The two pins are disconnected under normal condition. You may short them temporarily to realize system startup & shutdown or awaken the system from sleep state.

**PWR LED:** [POWER LED](#) status.

**COM3:**

(Type DB9), I/O serial port, it provides selectable RS422/RS485 serial signal output.

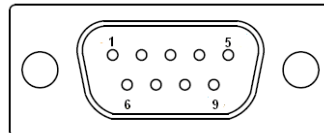

RS422 Type (option)		RS485 Type (option)	
Signal Name	Pin#	Pin#	Signal Name
422_RX+	1	1	NC
422_RX-	2	2	NC
422_TX-	3	3	485-
422_TX+	4	4	485+
Ground	5	5	Ground
NC	6	6	NC
NC	7	7	NC
NC	8	8	NC
NC	9	9	NC



**Note:**

Use COM3 RS422 or RS485 Function, please enter BIOS CMOS Setup. Path:  
BIOS Setup Utility \ Advanced /Super IO Configuration \ Serial Port3 Type:

**[RS-485]**

[RS-422]

**COM4:**

(Type DB9),Rear serial port, standard DB9 Male serial port is provided to make a direct connection to serial devices.

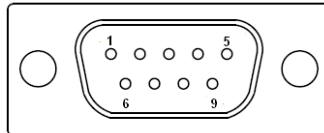

Pin#	Signal Name
1	DCD# (Data Carrier Detect)
2	RXD (Received Data)
3	TXD (Transmit Data)
4	DTR (Data Terminal Ready)
5	Ground
6	DSR (Data Set Ready)
7	RTS (Request To Send)
8	CTS (Clear To Send)
9	RI (Ring Indicator)

**USB10,USB11:**

(Double stack USB type A), I/O USB connector, it provides up to 2 USB2.0 ports, speed up to 480Mb/s.

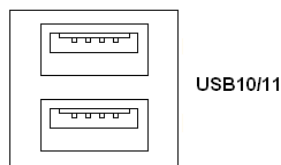

**CF:**

(CF\_Card socket), it is located at TB-522 and serves as an insert interface for Type I and Type II Compact Flash card. The operating voltage of CF card can be set as 3.3V or 5V. **The default setting of the product is 3.3V.**

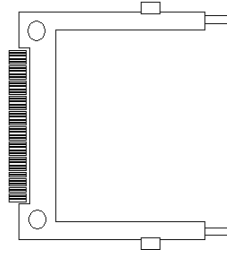

**42. TB-520P1(option):**

TB-520P1 connect to [ASB-M801T/ET](#) PC104+ connector, PC104+ is located at the top,

It provides one PCI slot.

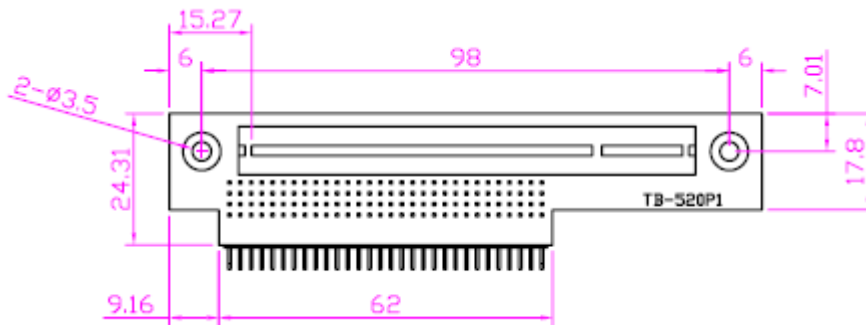

**43. TB-520P2:**

TB-520P1 connect to [ASB-M801T/ET](#) PC104+ connector, PC104+ is located at the top,

It provides two PCI slots.

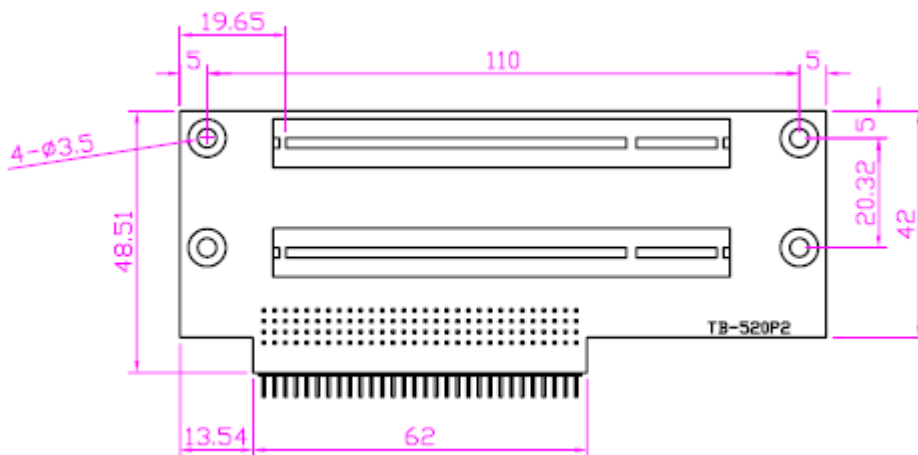

**44. TB-520P1E1:**

TB-520P1E1 connect to [ASB-M801T/ET](#) PC104+ and [PCIEX2](#) connector, PC104+ and [PCIEX2](#) are located at the top, It provides one PCI slot and one PCIE slot.

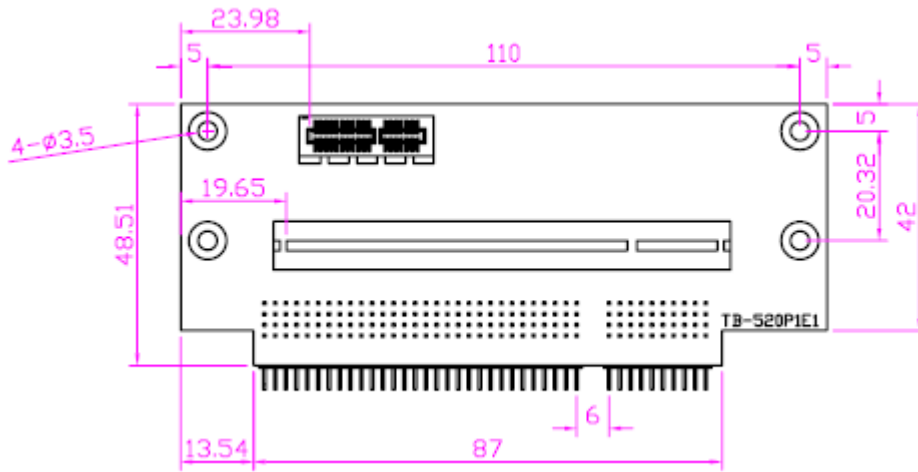

#### 45. TB-521P1:

TB-521P1 connect to ASB-M801B/EB PC104+ connector, PC104+ is located at the Bottom, It provides one PCI slot.

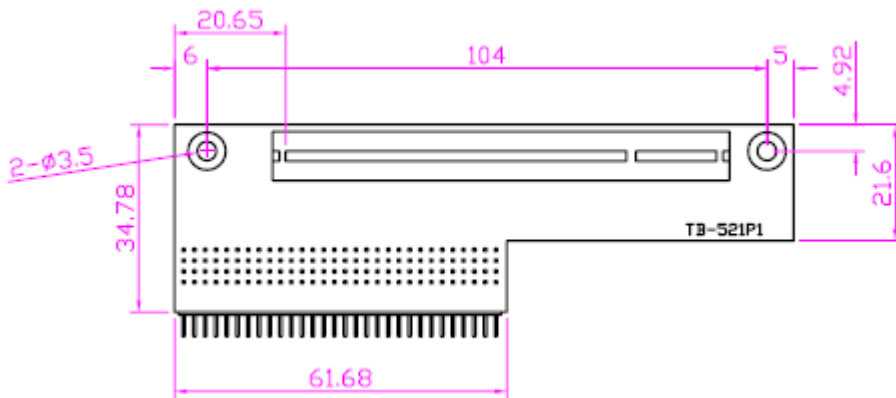

#### 46. TB-521P2:

TB-521P2 connect to ASB-M801B/EB PC104+ connector, PC104+ is located at the Bottom, It provides two PCI slots.

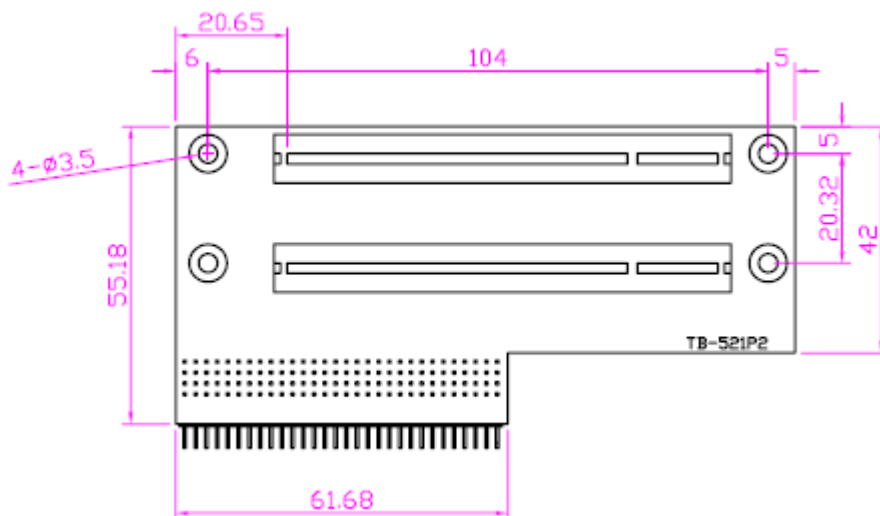

#### 47. TB-521P1E1:

TB-521P1E1 connect to ASB-M801B/EB PC104+ and PCIEX2 connector, PC104+ and PCIEX2 are located at the Bottom, It provides one PCI slot and one PCIE slot.

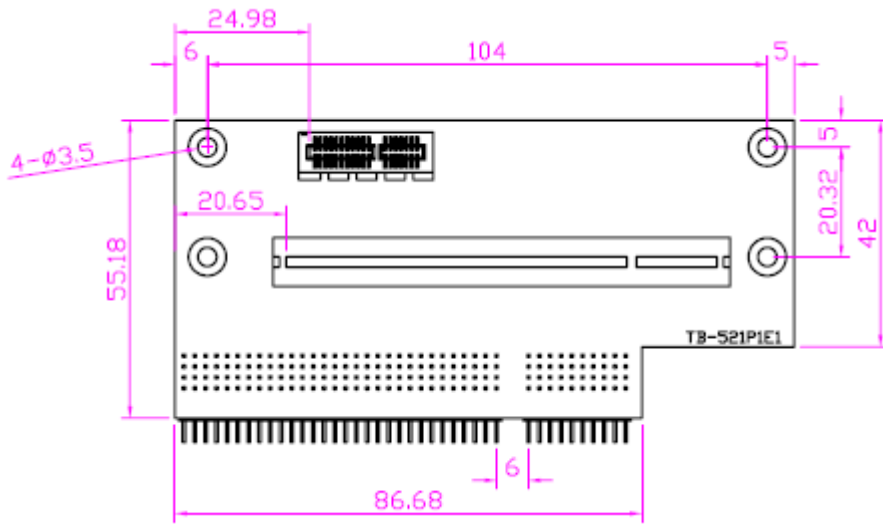



## 3.1 Operations after POST Screen

After CMOS discharge or BIOS flashing operation, the system will display the following screen for your further operation. Press F2 key to continue or F1 key to enter CMOS Setup.



After optimizing and exiting CMOS Setup, the POST screen displayed for the first time is as follows and includes basic information on BIOS, CPU, memory, and storage devices.

Press **F11** key to enter Boot Menu during POST, as shown by the following figure.

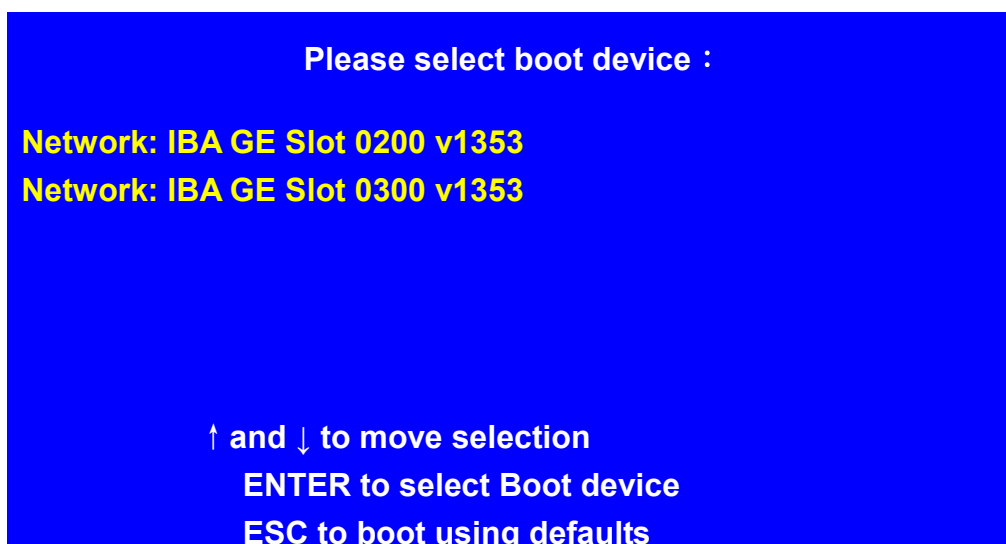

## 3.2 BIOS SETUP UTILITY

Press [Del] key to enter BIOS Setup utility during POST, and then a main menu containing system summary information will appear.

BIOS SETUP UTILITY	
Main	Advanced    PCIPnP    Boot    Security    Chipset    Exit
<b>System Overview</b>	User [ENTER] · [TAB]
<b>AMIBIOS</b>	or [SHIFT-TAB] to
Version : 08.00.15	Select a field
Build Date : 05/13/11	
ID : M801V001	Use[+] or [-] to
	configure system Time.
<b>Processor</b>	
Genuine Intel(R) CPU 575 @ 2.00GHz	
Speed :2000MHz	← Select Screen
	↑↓ Select Item
<b>System Memory</b>	+ - Charge Field
Size :1981MB	Tab Select Field
	F1 General Help
System Time [00:01:18]	F10 Save and Exit
System Date [Tue 05/15/2011]	ESC Exit
v02.61 © Copyright 1985-2006 American Megatrends , Inc.	

## 3.3 System Overview

BIOS SETUP UTILITY	
Main	Advanced    PCIPnP    Boot    Security    Chipset    Exit
<b>System Overview</b>	User [ENTER] · [TAB]
<b>AMIBIOS</b>	or [SHIFT-TAB] to
Version : 08.00.15	Select a field
Build Date : 05/13/11	
ID : M801V001	Use[+] or [-] to
	configure system Time.
<b>Processor</b>	
Genuine Intel(R) CPU 575 @ 2.00GHz	
Speed :2000MHz	← Select Screen
	↑↓ Select Item
<b>System Memory</b>	+ - Charge Field
Size :1981MB	Tab Select Field

System Time	[00:02:28]	F1	General Help
System Date	[Tue 05/13/2011]	F10	Save and Exit
		ESC	Exit
V02.61 © Copyright 1985-2006 American Mega trends , Inc.			

### System Time:

Set the system time, the time format is:

Hour : 0 to 23

Minute : 0 to 59

Second : 0 to 59

### System Date:

Set the system date, the date format is:

**Day:** Note that the 'Day' automatically changes when you set the date.

**Month:** 01 to 12

**Date:** 01 to 31

**Year:** 2009 to 2099

## 3.4 Advanced Settings

BIOS SETUP UTILITY	
Main	Advanced
PCIPnP	Boot
Security	Chipset
Exit	
<p><b>Advanced Settings</b></p> <p><b>Configure CPU</b></p>	
<p><b>WARNING: Setting wrong values In below sections may cause system to malfunction.</b></p> <ul style="list-style-type: none"> <li>▶ CPU Configuration</li> <li>▶ IDE Configuration</li> <li>▶ Super IO Configuration</li> <li>▶ Hardware Health Configuration</li> <li>▶ ACPI Configuration</li> <li>▶ AHCI Configuration</li> <li>▶ MPS Configuration</li> <li>▶ PCI Express Configuration</li> <li>▶ Smbios Configuration</li> <li>▶ USB Configuration</li> </ul>	
<p>← Select Screen</p>	

	↑↓    Select Item Enter    Charge Field F1        General Help F10      Save and Exit ESC      Exit
V02.61 © Copyright 1985-2006 American Mega trends , Inc.	

### 3.4.1 CPU Configuration

BIOS SETUP UTILITY	
Advanced	
<b>Configure advanced CPU settings</b> Module Version: 3F.10	For UP platforms, Leave it enabled.
Manufacturer : Intel Genuine Intel(R) CPU 575 @ 2.00GHz Frequency :2.00GHz FSB Speed : 668MHz Cache L1 :32 KB Cache L2 :1024 KB Ratio Actual Value :L2	For DP/MP serves, It may use to tune Performance to the Specific application.
Hardware Prefetcher                    [Enabled] Adjacent Cache Line Prefetch        [Enabled] Max CPUID Value Limit                [Disabled] Execute-Disable Bit Capability        [Enabled] Intel(R) C-SATAE tech                 [Disabled]	← Select Screen ↑↓ Select Item +- Charge Field F1 General Help F10 Save and Exit ESC Exit
V02.61 © Copyright 1985-2006 American Mega trends , Inc.	

**Hardware Prefetcher:**

[Enabled]

[Disabled]

**Adjacent Cache Line Prefetch:**

[Enabled]

[Disabled]

**Max CPUID Value Limit:**

[Disabled]

[Enabled]

**Execute-Disable Bit Capability:**

[Enabled]

[Disabled]

**Intel(R) C-STATE tech:**

[Disabled]

[Enabled]

**3.4.2 IDE Configuration**

The screenshot shows the BIOS SETUP UTILITY interface. At the top, there is a blue header with the text "BIOS SETUP UTILITY" and a sub-menu "Advanced" highlighted. Below this, the "IDE Configuration" section is visible. It includes options for SATA#1 Configuration (set to [Compatible]), Primary IDE Master (set to [Not Detected]), Primary IDE Slaver (set to [Not Detected]), Secondary IDE Master (set to [Not Detected]), Secondary IDE Slaver (set to [Not Detected]), Third IDE Master (set to [Not Detected]), and Fourth IDE Master (set to [Hard Disk]). At the bottom of the IDE Configuration section, there are options for "Hard Disk Write Protect" (set to [Disabled]) and "IDE Detect Time Out (Sec)" (set to [35]). On the right side of the screen, there is a legend for navigation keys: ← Select Screen, ↑↓ Select Item, +- Change Field, F1 General Help, F10 Save and Exit, and ESC Exit.

**SATA#1 Configuration:**

- [Compatible]**
- [Disabled]
- [Enhanced]

**Configure SATA as:**

- [IDE]**
- [RAID]
- [AHCI]

**SATA#2 Configuration:**

- [Enhanced]**
- [Disabled]

**Hard Disk Write Protect:**

- [Disabled]**
- [Enabled]

**IDE Detect Time Out :**

- [35]**
- [0]
- [5]
- [10]
- [15]
- [20]
- [25]
- [30]

**ATA(P) 80Pin Cable Detection:**

- [Host & Device]
- [Host]
- [Device]

**3.4.3 Super IO Configuration**

BIOS SETUP UTILITY		
Advanced		
Configure Win627UHG Super IO Chipset		Allow BIOS to Select
Serial Port1 Address	[3F8]	Serial Port Base
Serial Port2 Address	[2F8]	Address.
Serial Port3 Address	[3E8]	
Serial Port3 IRQ	[IRQ4]	
Serial Port3 Mode	[RS-485]	
Serial Port4 Address	[2E8]	
Serial Port4 IRQ	[IRQ3]	
Serial Port5 Address	[238]	
Serial Port5 IRQ	[IRQ5]	
Serial Port6 Address	[228]	
Serial Port6 IRQ	[IRQ7]	
		← Select Screen
		↑↓ Select Item
		+ - Charge Field
		F1 General Help
		F10 Save and Exit
		ESC Exit
V02.61 © Copyright 1985-2006 American Mega trends , Inc.		

**Serial Port3 Mode:**

COM3 Options: **[RS485 ]**  
 [RS422]  
 [RS422] for RS422 Mode  
 [RS485] for RS485 Mode

**3.4.4 Hardware Health Configuration**

BIOS SETUP UTILITY		
Advanced		
Hardware Health Configuration		
System Temperature	:33 °C/91 °F	55°C/131°F
CPU Temperature	:30 °C/86 °F	60°C/140°F
CPUFAN Speed	:4800 RPM	65°C/149°F

		<b>70°C/158°F</b>
<b>Vcore</b>	<b>:1.064V</b>	
<b>AVCC</b>	<b>:5.058V</b>	
<b>5VCC</b>	<b>:5.067 V</b>	
<b>3.3V</b>	<b>:3.264 V</b>	
<b>5.0V</b>	<b>:5.029 V</b>	
<b>12V</b>	<b>:12.042 V</b>	
<b>VSb</b>	<b>:5.058 V</b>	
<b>VBAT</b>	<b>:3.366 V</b>	
<b>Smart Fan Configuration</b>		← Select Screen
Maximum CPU Temperature	[60°C/140°F]	↑↓ Select Item
Maximum PWM Duty for CPU Fan	[60%]	+ - Charge Field
		F1 General Help
		F10 Save and Exit
		ESC Exit
<b>V02.61 © Copyright 1985-2006 American Mega trends , Inc.</b>		

### System Temperature:

Show you the current system temperature.

### CPU Temperature:

Show you the current CPU temperature.

### CPUFAN Speed:

Show you the current CPU Fan operating speed.

### Maximum CPU Temperature:

[60°C/140°F]

[55°C/131°F]

[65°C/149°F]

[70°C/158°F]

### Minimum PWM Duty for CPU Fan:

[60%]

[50%]

[70%]

[80%]

## 3.4.5 ACPI Configuration

ACPI Setting:

[Advanced ACPI Configuration]



ACPI Version Features:

**[ACPI V1.0]**

[ACPI V2.0]

[ACPI V3.0]

ACPI APIC support:

**[Enabled]**

[Disabled]

AMI OEMB table:

**[Enabled]**

[Disabled]

Headless mode:

**[Disabled]**

[Enabled]

[Chipset ACPI Configuration]:

APIC ACPI SCI IRQ:

**[Disabled]**

[Enabled]

High Performance Event Timer:

**[Disabled]**

[Enabled]

### 3.4.6 AHCI Configuration

BIOS SETUP UTILITY	
Advanced	
<b>AHCI Setting</b>	Enables For supporting
AHCI BIOS Support [Enabled]	
AHCI CD/DVD Boot Time out [35]	
▶ AHCI Port0 [Not Detected]	
▶ AHCI Port1 [Not Detected]	

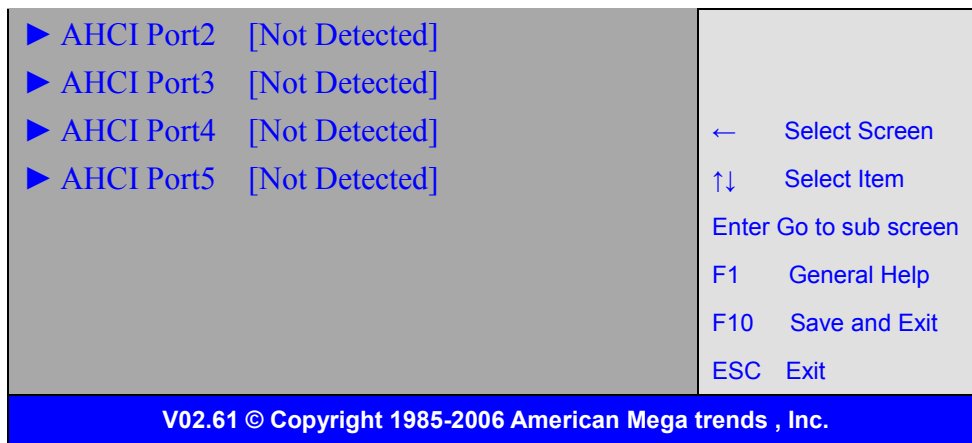

While entering setup, BIOS auto detects the presence of IDE devices. This displays the status of auto detecting of IDE devices

### 3.4.7 MPS Configuration

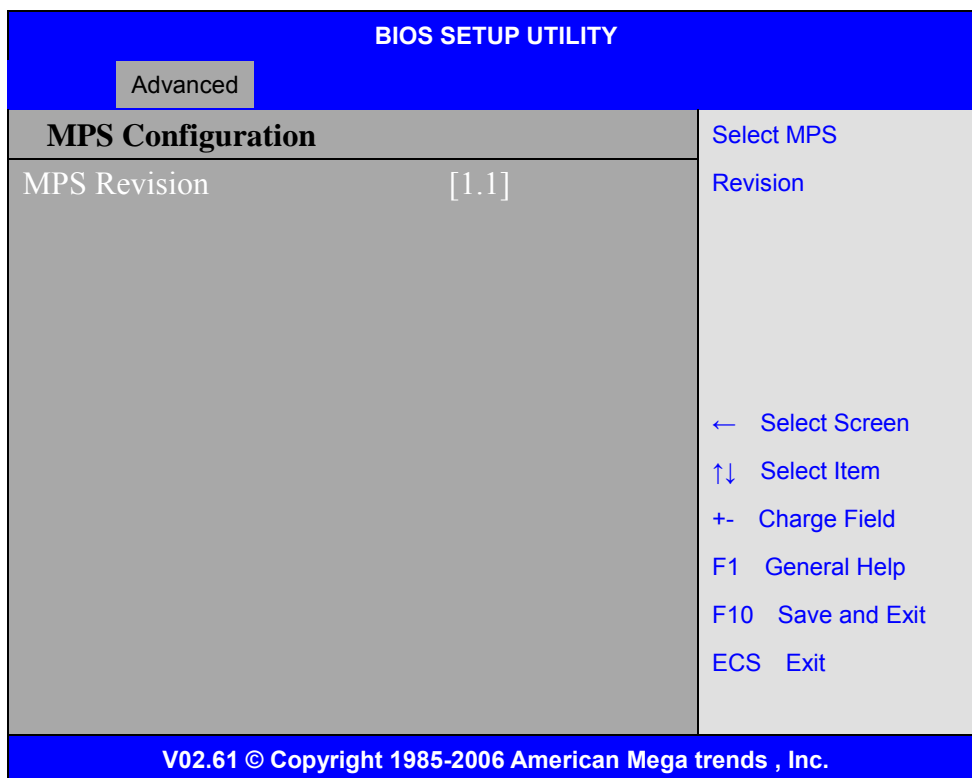

MPS Revision:

**[1.1]**

[1.4]

### 3.4.8 PCI Express Configuration



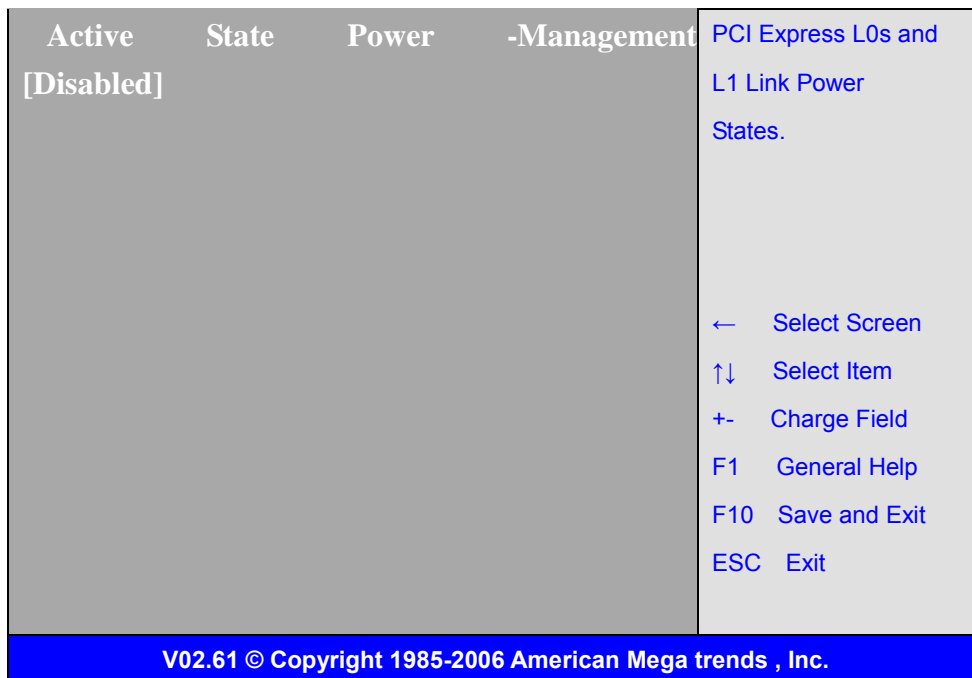

Active State Power Management:

**[Disabled]**

[Enabled]

### 3.4.9 Smbios Configuration

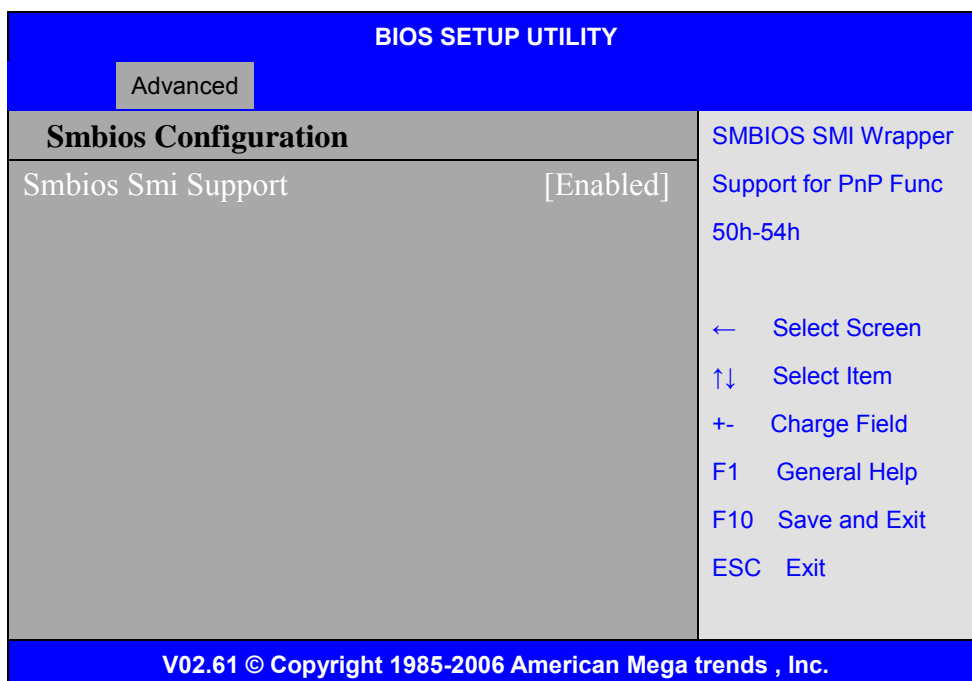

Smbios Smi Support:

**[Enabled]**

[Disabled]

### 3.4.10 USB Configuration

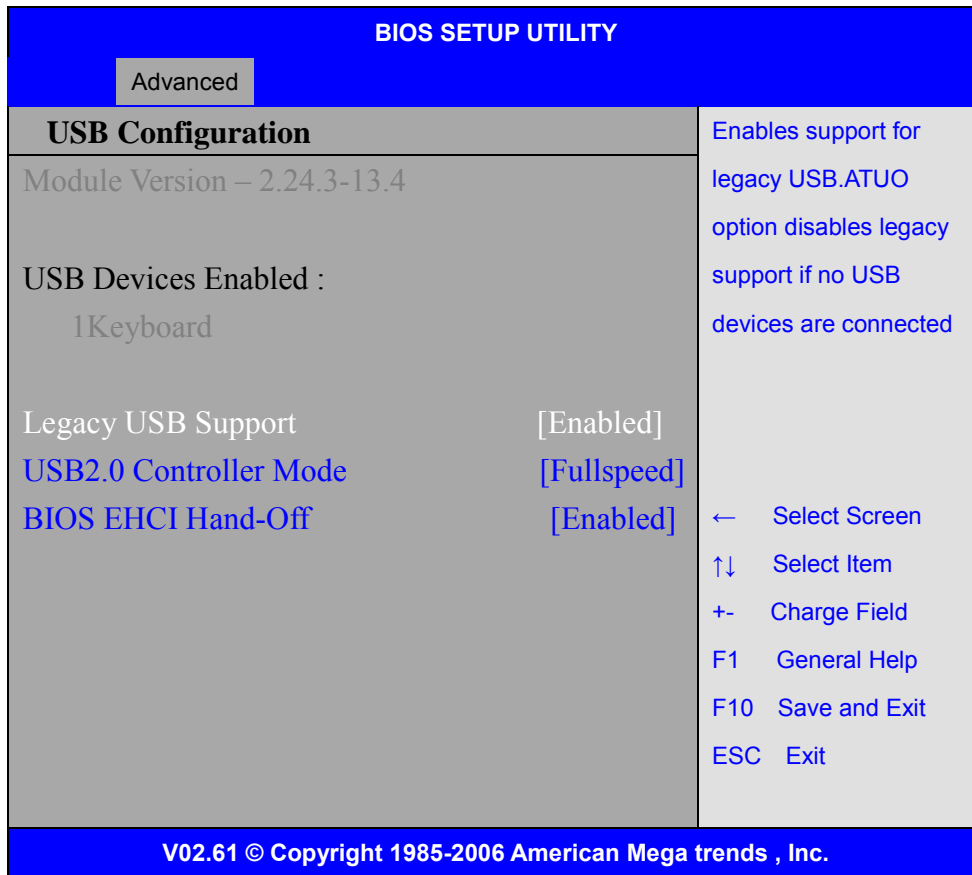

#### Legacy USB Support:

[Enabled]

[Disabled]

#### USB2.0 Controller Mode:

[FullSpeed]

[HiSpeed]

#### BIOS EHCI Hand-Off:

[Enabled]

[Disabled]

## 3.5 Advanced PCI/PnP Settings

This part describes configurations to be made on PCI bus system. PCI, namely Personal Computer Interconnect, is a computer bus that allows I/O device to operate nearly as fast as CPU in its own way. Some technical terms will be mentioned here. **We recommend that non-professional users not make changes from factory default settings.**

BIOS SETUP UTILITY						
Main	Advanced	PCIPNP	Boot	Security	Chipset	Exit
<b>Advanced PCI/PnP Settings</b>						Clear NURAM during System Boot.
<b>WARNING: Setting wrong values In below sections may cause system to malfunction.</b>						
Clear NVRAM						[No]
Plug & Play O/S						[No]
PCI Latency Timer						[64]
Allocate IRQ to PCI VGA						[Yes]
Palette Snooping						[Disabled]
PCI IDE BusMaster						[Disabled]
OffBoard PCI/ISA IDE Card						[Auto]
IRQ3						[Available]
IRQ4						[Available]
IRQ5						[Available]
IRQ7						[Available]
IRQ9						[Available]
IRQ10						[Available]
IRQ11						[Available]
						← Select Screen
						↑↓ Select Item
						+ - Change Field
						F1 General Help
						F10 Save and Exit
						ESC Exit
V02.61 © Copyright 1985-2006 American Mega trends , Inc.						

**Clear NVRAM:**

[No]  
[Yes]

**Plug & Play OS:**

[No]  
[Yes]

**PCI Latency Timer:**

[64]

[32]

[96]

[128]

[160]

[192]

[224]

[248]

**Allocate IRQ to PCI VGA:**

[Yes]

[No]

**Palette Snooping:**

[Disabled]

[Enabled]

**PCI IDE BusMaster:**

[Disabled]

[Enabled]

**OffBoard PCI/ISA IDE Card:**

Some PCI IDE cards may require this to be set to the PCI slot number that is holding the card. Auto:Works for most PCI IDE Cards.

[Auto]

[PCI Slot1]

[PCI Slot2]

[PCI Slot3]

[PCI Slot4]

[PCI Slot5]

[PCI Slot6]

**IRQ3/4/5/7/9/10/11/14/15:**

[Available]

[Reserved]

Available: Specified IRQ is available to be used by PCI/PnP devices.

Reserved: Specified IRQ is reserved for use by legacy ISA devices.

**DMA Channel 0/1/3/5/6/7:**

[Available]

[Reserved]

Available: Specified DMA is available to be used by PCI/PnP devices.

Reserved: Specified DMA is reserved for use by legacy ISA devices.

### Reserved Memory Size:

Size of memory block to reserve for legacy ISA devices.

[Disabled]

[16k]

[32k]

[64k]

## 3.6 Boot Settings



### Boot Setting Configuration :

Configure Settings during System Boot.

Quick Boot:

[Enabled]

[Disabled]

Allows BIOS to skip certain tests while booting .This will decrease the time needed to boot the system.

Quiet Boot:

**[Disabled]**

[Enabled]

Disabled: Displays normal POST messages.

Enabled: Displays OEM logo instead of POST messages.

AddOn ROM Display Mode:

Set display mode for Option ROM.

**[Force BIOS]**

[Keep Current]

Bootup Num—Lock:

Select Power-on state for Numlock.

**[On]**

[Off]

Wait For 'F1' If Error:

Wait for F1 key to be pressed if error occurs.

**[Enabled]**

[Disabled]

Hit 'DEL' Messgae Display :

Displays "press" DEL to run Setup in POST.

**[Enabled]**

[Disabled]

Interrupt 19 Capture:

Enabled: Allows option ROMs to trap interrupt 19.

**[Disabled]**

[Enabled]

### **Boot Device Priority:**

Specifies the Boot Device Priority sequence.

### **Hard Disk Devices :**

Specifies the Boot Device Priority sequence from available Hard Drives.



## 3.7 Security Settings

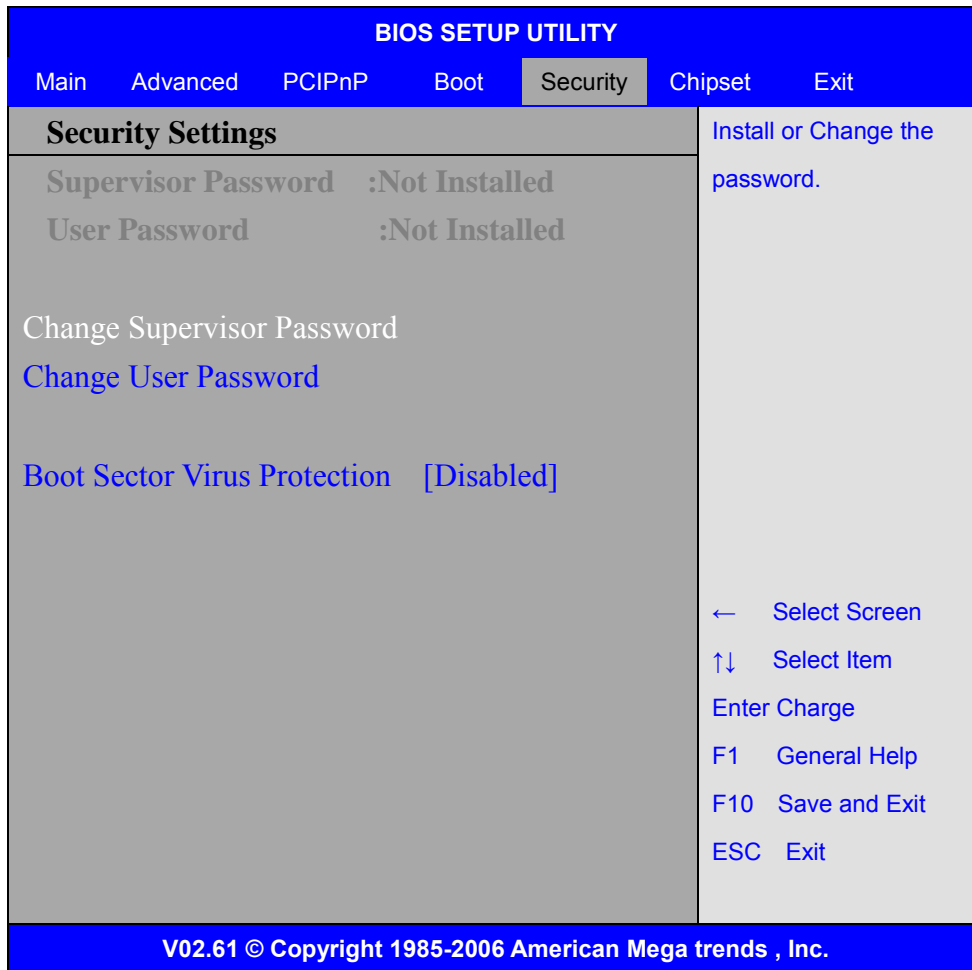

Change Supervisor Password:  
Install or Change the password.

Change User Password:  
Install or Change the password.

Password Check:  
[Setup]  
[Always]  
Setup: Check password while invoking setup.  
Always: Check password while invoking setup as well as on each boot.

Boot Sector Virus Protection:  
[Disabled]  
[Enabled]  
Enabled / Disabled Boot Sector Virus Protection.

Type the password with up to 6 characters and then press <Enter> key. This will

clear all previously typed CMOS passwords. You will be requested to confirm the password. Type the password again and press <Enter> key. You may press <Esc> key to abandon password entry operation.

To clear the password, just press <Enter> key when password input window pops up. A confirmation message will be shown on the screen as to whether the password will be disabled. You will have direct access to BIOS setup without typing any password after system reboot once the password is disabled.

Once the password feature is used, you will be requested to type the password each time you enter BIOS setup. This will prevent unauthorized persons from changing your system configurations.

Also, the feature is capable of requesting users to enter the password prior to system boot to control unauthorized access to your computer. Users may enable the feature in Security Option of Advanced BIOS Features. If Security Option is set to System, you will be requested to enter the password before system boot and when entering BIOS setup; if Security Option is set to Setup, you will be requested for password for entering BIOS setup.

## 3.8 Advanced Chipset Settings





Note: Due to limited address length of BIOS, only a portion of panel parameters are listed in BIOS Setup. If the connected panel is not included in the parameter list, display problem will occur. In this case, Please do not change BIOS setup.

### 3.8.1 North Bridge Configuration

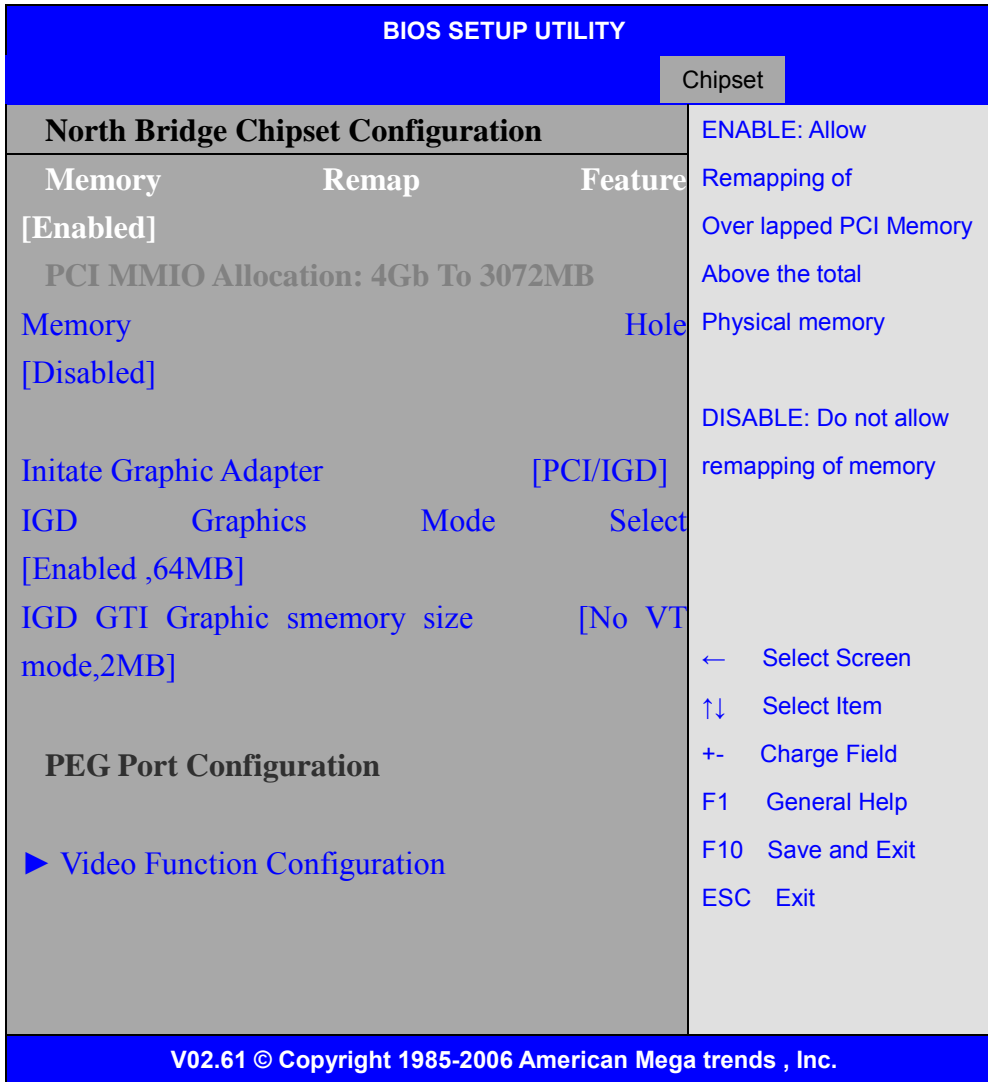

#### Memory Remap Feature:

[Enabled]

[Disabled]

#### Memory Hole:

[Disabled]

[15MB-16MB]

#### Initiate Graphic Adapter:

Select which graphics controller to use as the primary boot device.

[PCI/IGD]

[IGD]

**IGD Graphics Mode Select:**

[Enabled, 64MB]

[Disabled]

[Enabled, 32MB]

[Enabled, 128MB]

**Video Function Configuration:**

BIOS SETUP UTILITY	
Chipset	
Video Function Configuration	Options
DVMT Mode Select [DVMT Mode]	Fixed Mode DVMT Mode
DVMT/FIXED [256MB]	Memory
Boot [VBIOS-Default]	Device
Flat Panel Type [1024x768 18bit 1c]	
Backlight [VBIOS-Default]	Support ← Select Screen
Backlight Control Level [Level 8]	↑↓ Select Item
Backlight Control Mode [DC]	+ - Charge option
Backlight [VBIOS-Default]	F1 General Help
	F10 Save and Exit
	ESC Exit

V02.61 © Copyright 1985-2006 American Mega trends , Inc.

**DVMT Mode Select:**

[DVMT Mode]

[FIXED Mode]

**DVMT/FIXED Memory Size:**

[256MB]

[128MB]

[Maximum DVMT]

**Boot Display Device:**

[VBIOS-Default]

[CRT]

[HDMI]

[CRT + HDMI]

[LVDS]

[CRT + LVDS]

**Flat Panel Type:**

[1024x 768 18bit 1ch]

[640x480 18bit 1ch]

[800x480 18bit 1ch]

[800x600 18bit 1ch]

[1280x800 18bit 1ch]

[1366x768 18bit 1ch]

[1024x768 24bit 2ch]

[1280x1024 24bit 2ch]

[1440x900 24bit 2ch]

[1600x900 24bit 2ch]

[1680x1050 24bit 2ch]

[1920x1080 24bit 2ch]

**Backlight Control Support**

[VBIOS-Default]

[Both BLC & BIA Disabled]

[BLC Enabled]

**Backlight Control Control:**

[Level8]

[Level0]

[Level1]

[Level2]

- [Level3]
- [Level4]
- [Level6]
- [Level7]
- [Level9]
- [Level10]
- [Level11]
- [Level12]
- [Level13]
- [Level14]
- [Level15]



Note: Panel support PWM Function.

**Backlight Control Mode:**

- [DC]
- [PWM]

**Backlight Image Adaptation:**

- [VBIOS-Default]
- [BIA Disabled]
- [BIA Enabled at Level1]
- [BIA Enabled at Level2]
- [BIA Enabled at Level3]
- [BIA Enabled at Level4]
- [BIA Enabled at Level5]

**3.8.2 South Bridge Configuration:**

BIOS SETUP UTILITY		
		Chipset
South Bridge Chipset Configuration		Options
USB Functions [12 USB Ports]		Disabled
USB2.0 Controller	[Enabled]	2 USB Ports
Keep USB Power at S5	[Enabled]	4 USB Ports
Wireless Controller	[Enabled]	6 USB Ports
HAD Controller	[Enabled]	8 USB Ports
SMBUS Controller	[Enabled]	10 USB Ports
		12 USB Ports

SLP_S4# Min. Assertion Width	[4 to 5	
Seconds]		
Restore on AC Power loss	[Power off]	
PCIE Ports Configuration		
PCIE Port 0	[Auto]	← Select Screen
PCIE Port 1	[Auto]	↑↓ Select Item
PCIE Port 2	[Auto]	+ - Charge Field
PCIE Port 3	[Auto]	F1 General Help
PCIE Port 4	[Auto]	F10 Save and Exit
PCIE High Priority Port	[Disabled]	ESC Exit
V02.61 © Copyright 1985-2006 American Mega trends , Inc.		

**USB Functions:**

**[12 USB Ports]**

[Disabled] ,

[2 USB Ports]

[4 USB Ports]

[6 USB Ports]

[8 USB Ports]

[10 USB Ports]

**USB 2.0 Controller:**

**[Enabled]**

**Keep USB Power at S5:**

**[Enabled]**

[Disabled]

**Wireless Controller**

**[Enabled]**

[Disabled]

**HDA Controller:**

**[Enabled]**

[Disabled]

**SMBUS Controller:**

**[Enabled]**

[Disabled]

**SLP\_S4# Min. Assertion Width:**

**[4 to 5 Seconds]**

[3 to 4 Seconds]

[2 to 3 Seconds]

[1 to 2 Seconds]

**Restore on AC Power Loss:**

**[Power Off]**

[Power On]

[Last Status]

**PCIE Ports Configuration:**

PCIE Port 0:

**[Auto]**

[Enabled]

[Disabled]

PCIE Port 1:

**[Auto]**

[Enabled]

[Disabled]

PCIE Port 2:

**[Auto]**

[Enabled]

[Disabled]

PCIE Port 3:

**[Auto]**

[Enabled]

[Disabled]

PCIE Port 4:

**[Auto]**

[Enabled]

[Disabled]

PCIE High priority Port:

**[Disabled]**

[Port 0]

[Port1]



[Port2]

[Port3]

[Port4]

[Port5]

PCIE Port 0 IOxAPIC Enabled:

PCIE Port 1 IOxAPIC Enabled:

PCIE Port 2 IOxAPIC Enabled:

PCIE Port3 IOxAPIC Enabled:

PCIE Port4 IOxAPIC Enabled:

PCIE Port5 IOxAPIC Enabled:

**[Disabled]**

[Enabled]

### **3.9 Exit Options**

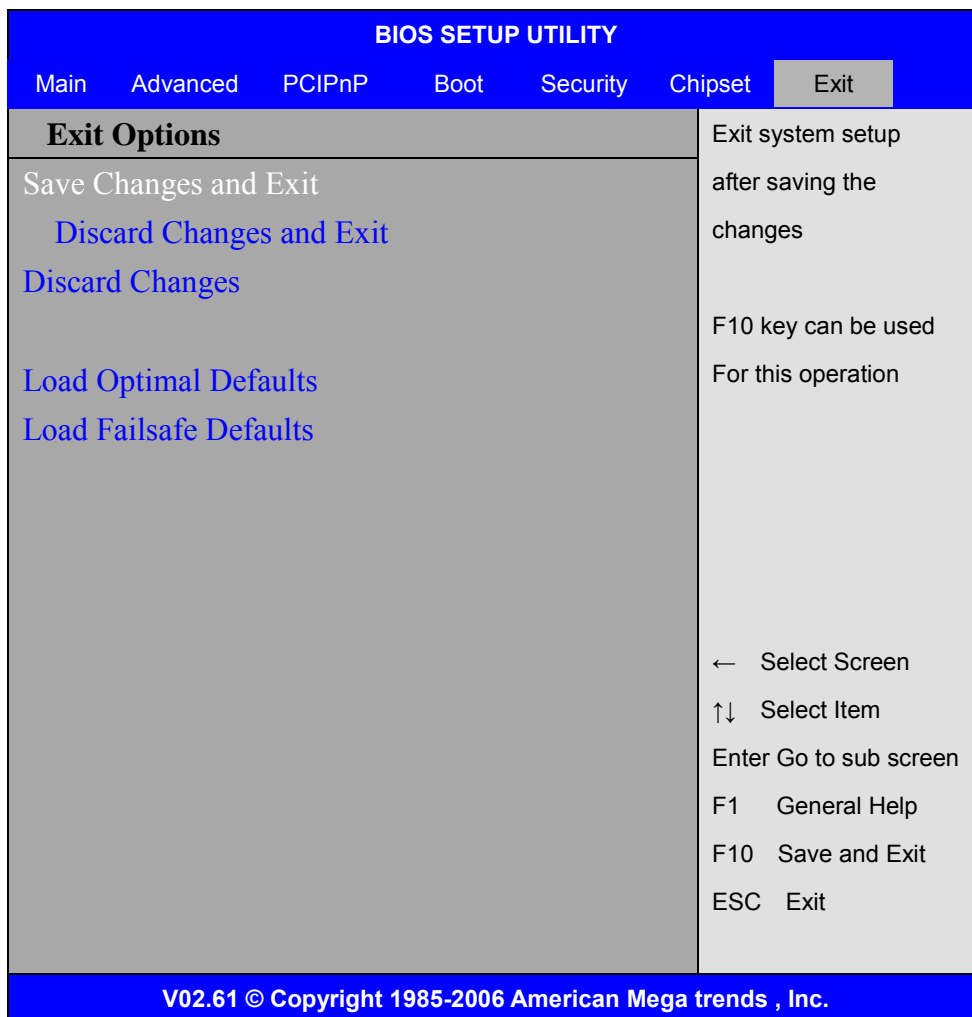

#### **Save Changes and Exit:**

Save configuration changes and exit setup?

(F10 key can be used for this operation)

[OK]

[Cancel]

**Discard Changes and Exit:**

Discard Changes and Exit setup?

(ESC key can be used for this operation)

[OK]

[Cancel]

**Discard Changes:**

Discard changes?

(F7 key can be used for this operation)

[OK]

[Cancel]

**Load Optimal Defaults:**

Load Optimal Defaults?

(F9 key can be used for this operation)

[OK]

[Cancel]

**Load FailSafe Defaults:**

Load FailSafe Defaults?

(F9 key can be used for this operation)

[OK]

[Cancel]

# Chapter 4 Installation of Drivers

This chapter describes the installation procedures for software and drivers under the windows XP. The software and drivers are included with the motherboard. The contents include **Intel chipset driver** **VGA driver** **LAN drivers** **Audio driver** **.NET framework 3.5 driver** Installation instructions are given below.

## Important Note:

After installing your Windows operating system (Windows XP), you must install first the Intel Chipset Software Installation Utility before proceeding with the installation of drivers.



**Aplex Technology Drivers**

**Box PC**

**ACS - 2675C - XP**

**DRIVERS**

- Intel GM45/ICH9M Chipset Driver
- Intel(R) VGA Chipset Driver
- Intel(R) Network Adapter
- Realtek ALC662 Audio Codec Driver
- Microsoft .NET Framework 3.5 Service

**OTHERS**

- User Manual

**APLEX** <http://www.aplex.com.tw> View EXIT

## 4.1 Intel Chipset Driver

To install the Intel chipset driver, please follow the steps below.

Step 1: Select Chipset from the list



Follow the step-by-step installation process to install the driver.







Click Finish, when the installation process is complete, the Setup Complete screen appears. See as picture.

## 4.2 Intel Graphics Media Accelerator driver

To install the VGA drivers, follow the steps below to proceed with the installation.

1. Click Intel(R) GM45 Chipset Family Graphics Driver.



Follow the step-by-step installation process to install the Graphics Media Accelerator driver.

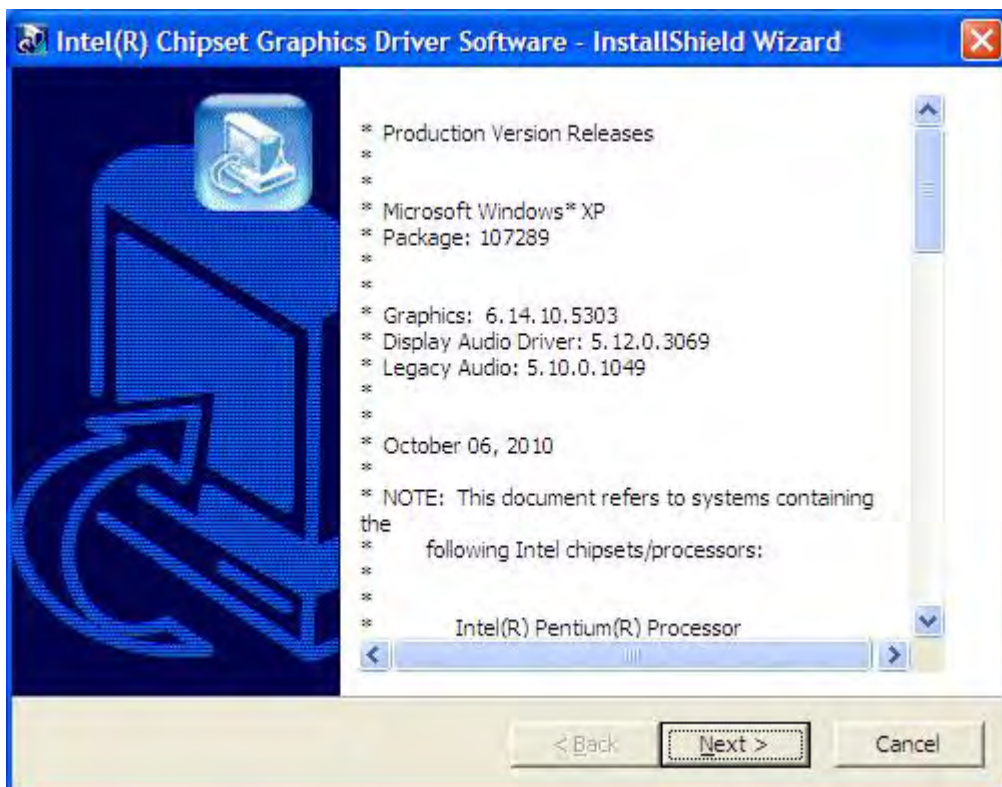

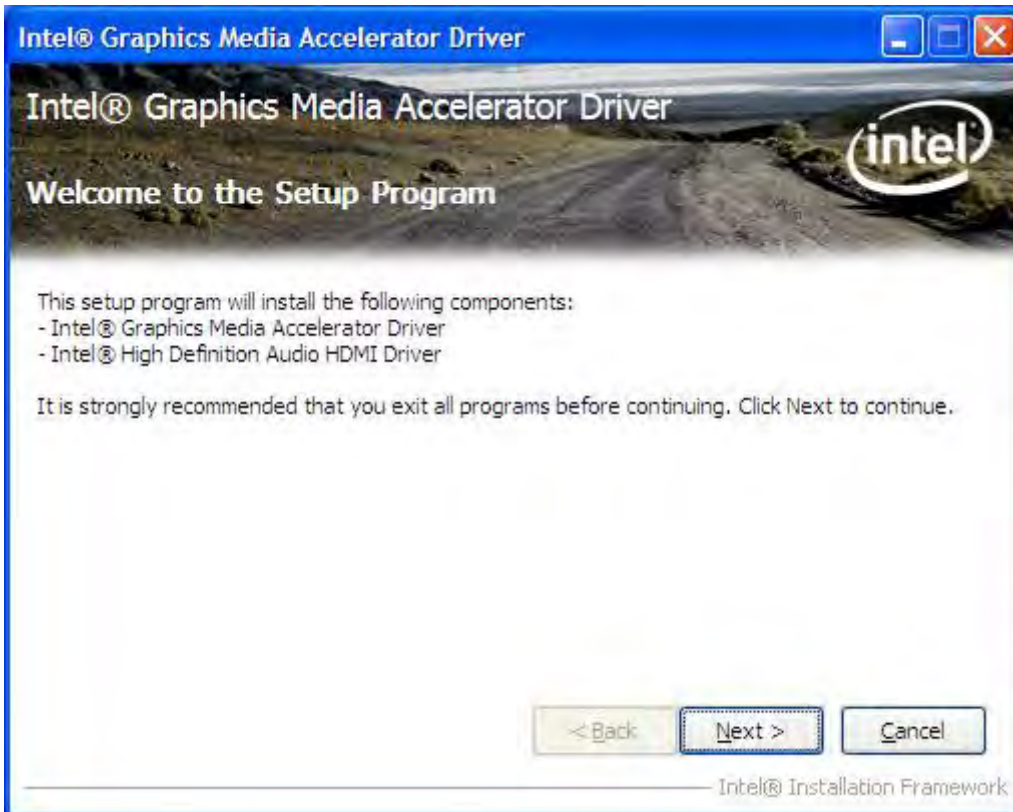
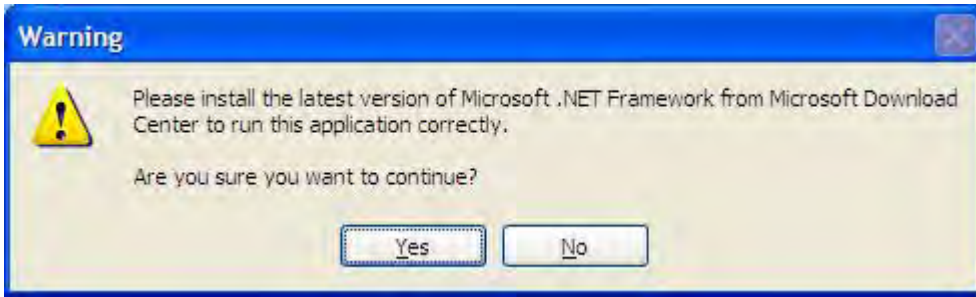



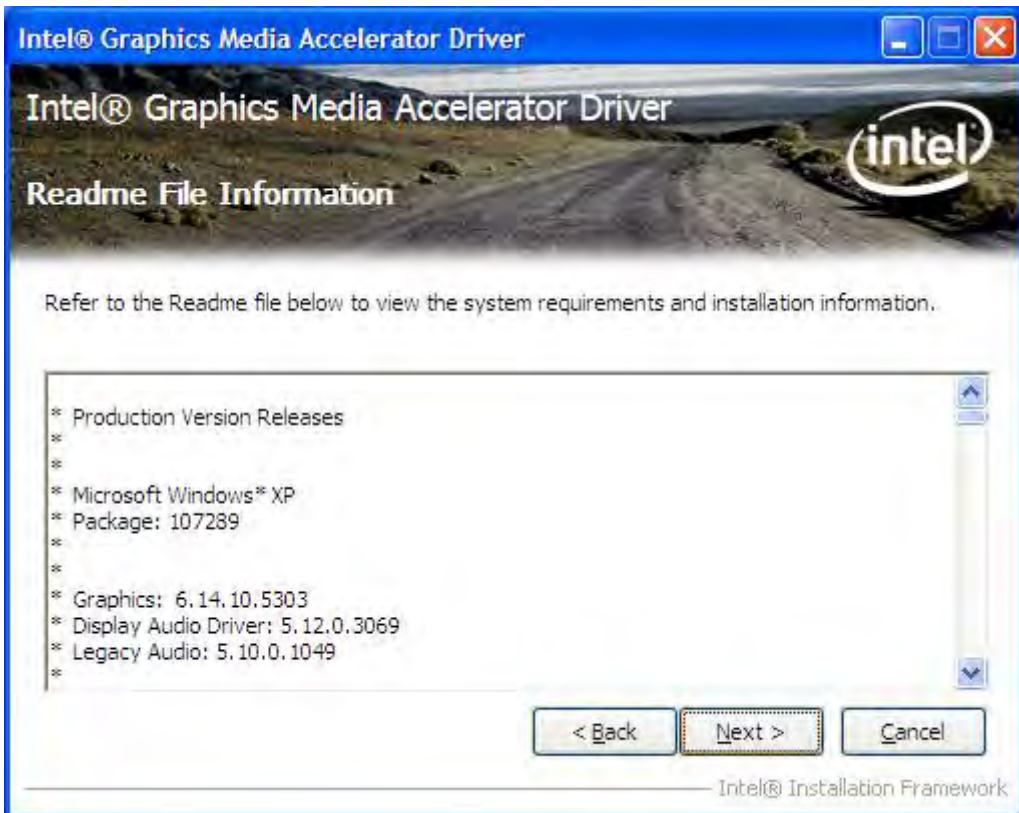

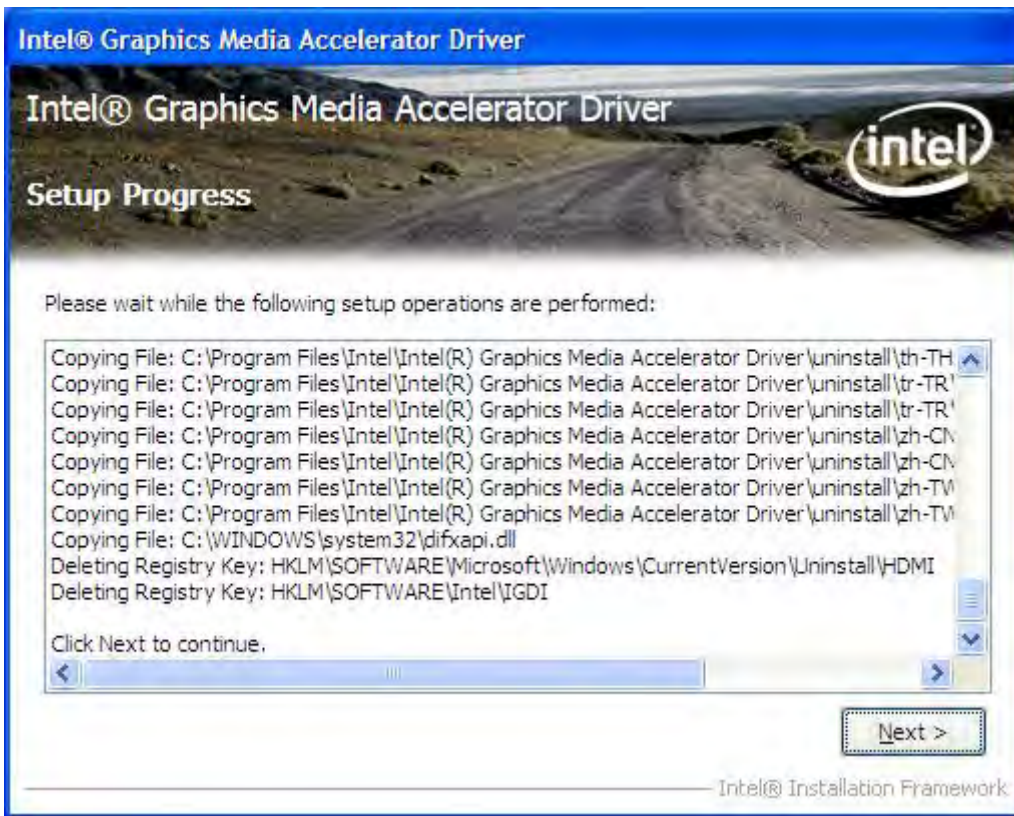

Click FINISH; A Driver Installation Complete.

## 4.3 Intel 82574L LAN Device Driver

To install the Intel R 82574L Gigabit LAN connect device driver, please follow the steps below.  
Select LAN from the list



Follow the step-by-step installation process to install the LAN driver.



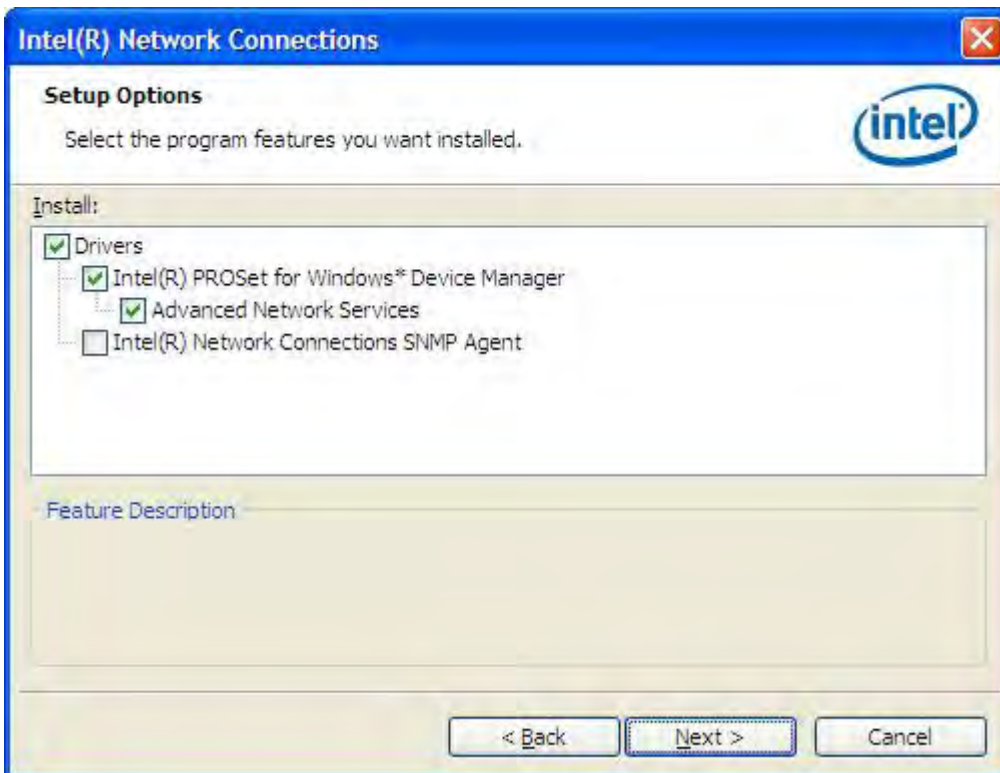
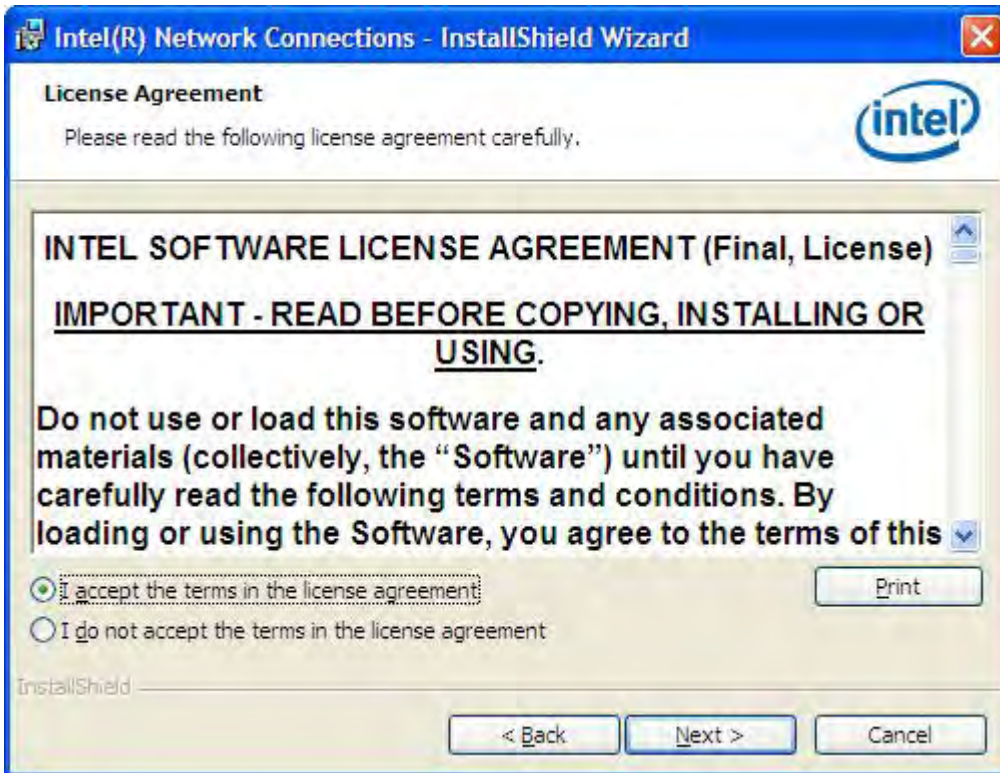

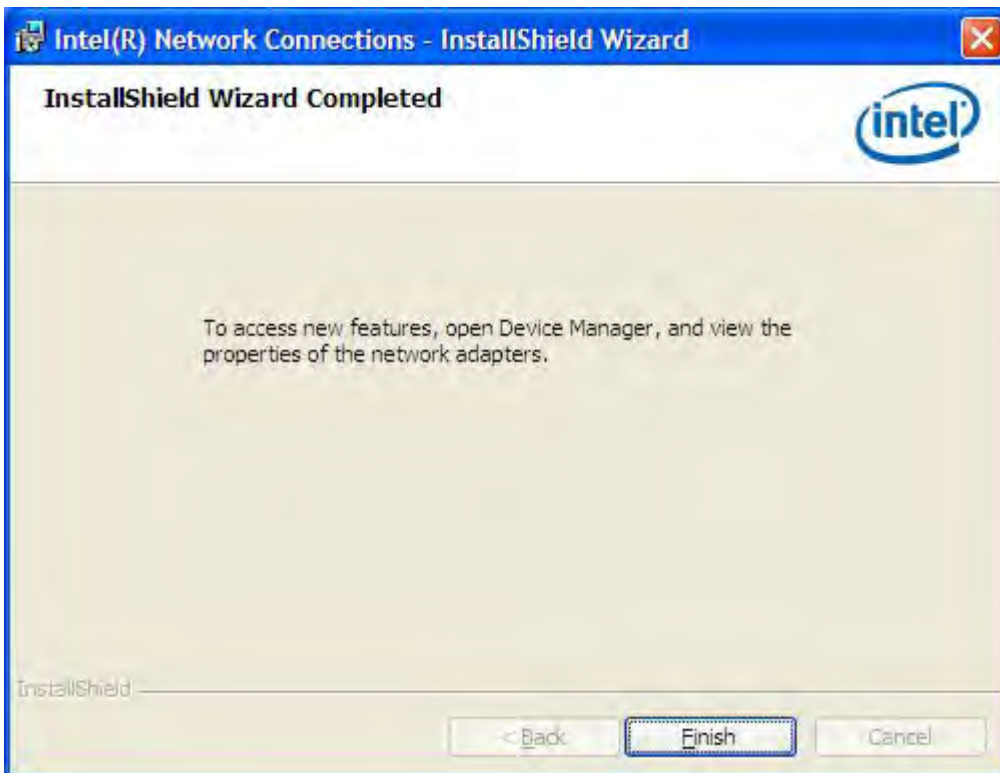

Click FINISH; A Driver Installation Complete.

## 4.4 Realtek ALC662 HD Audio Driver Installation

To install the Realtek High Definition (HD) Audio driver, please follow the steps below.  
Select Audio from the list



Follow the step-by-step installation process to install the Realtek HD Audio driver.

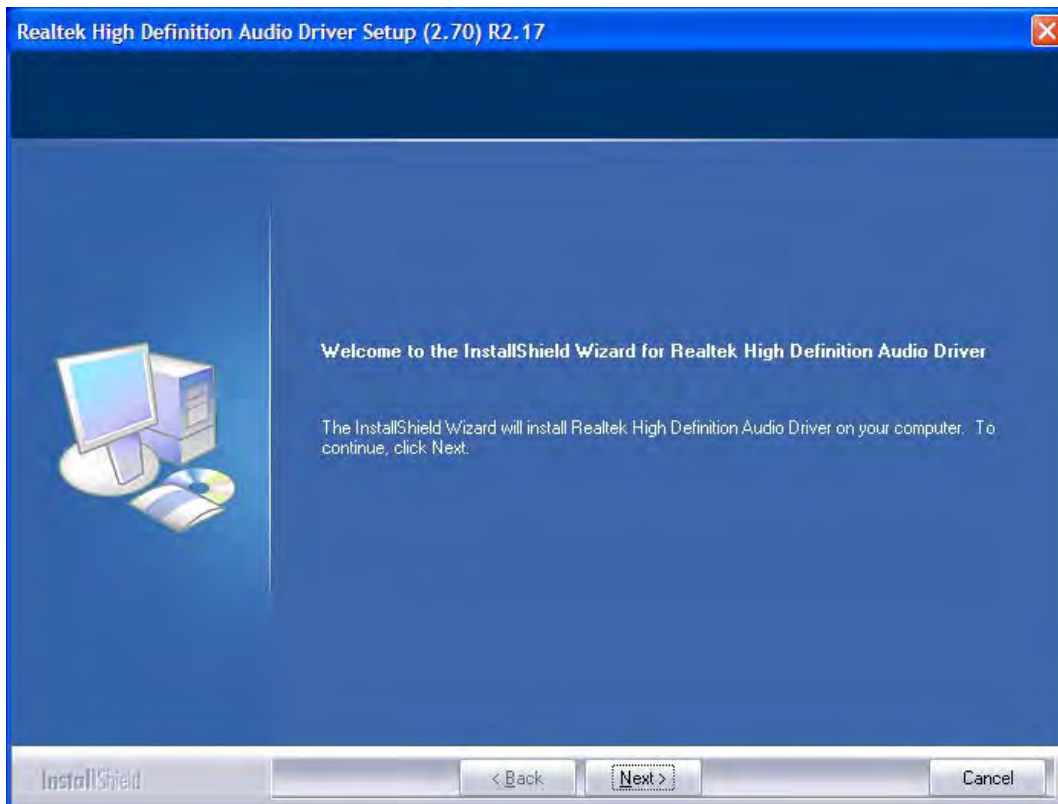

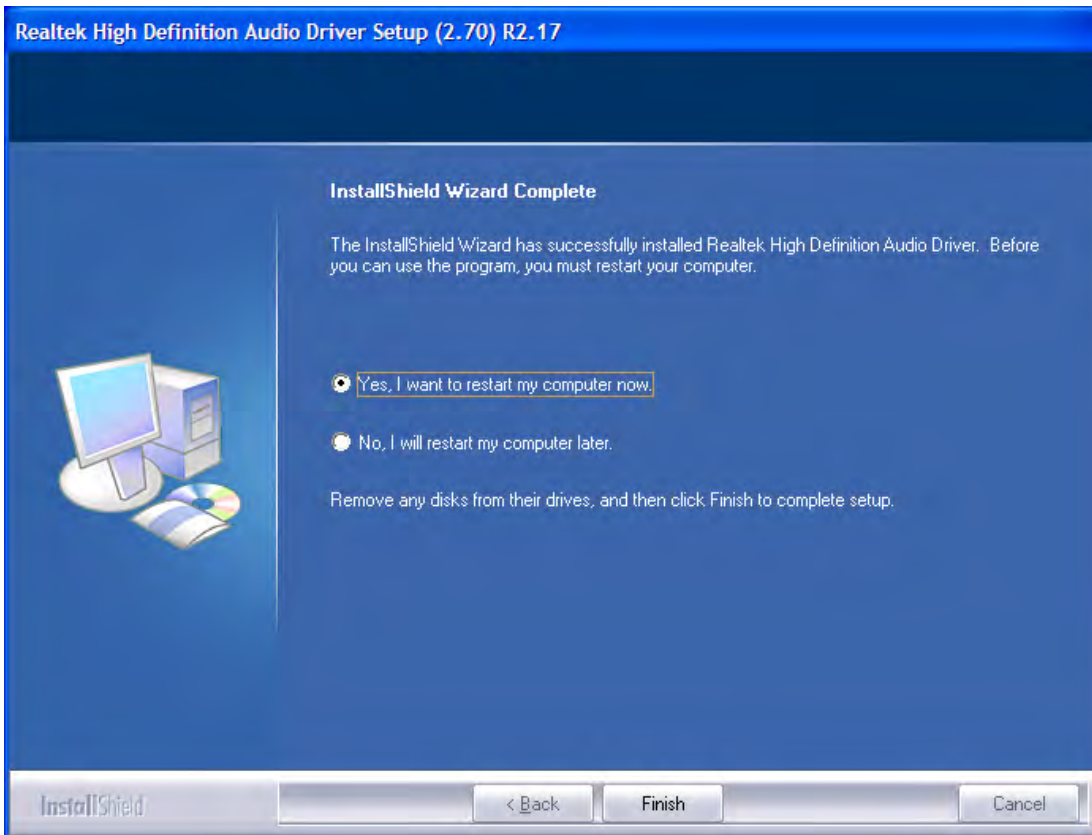
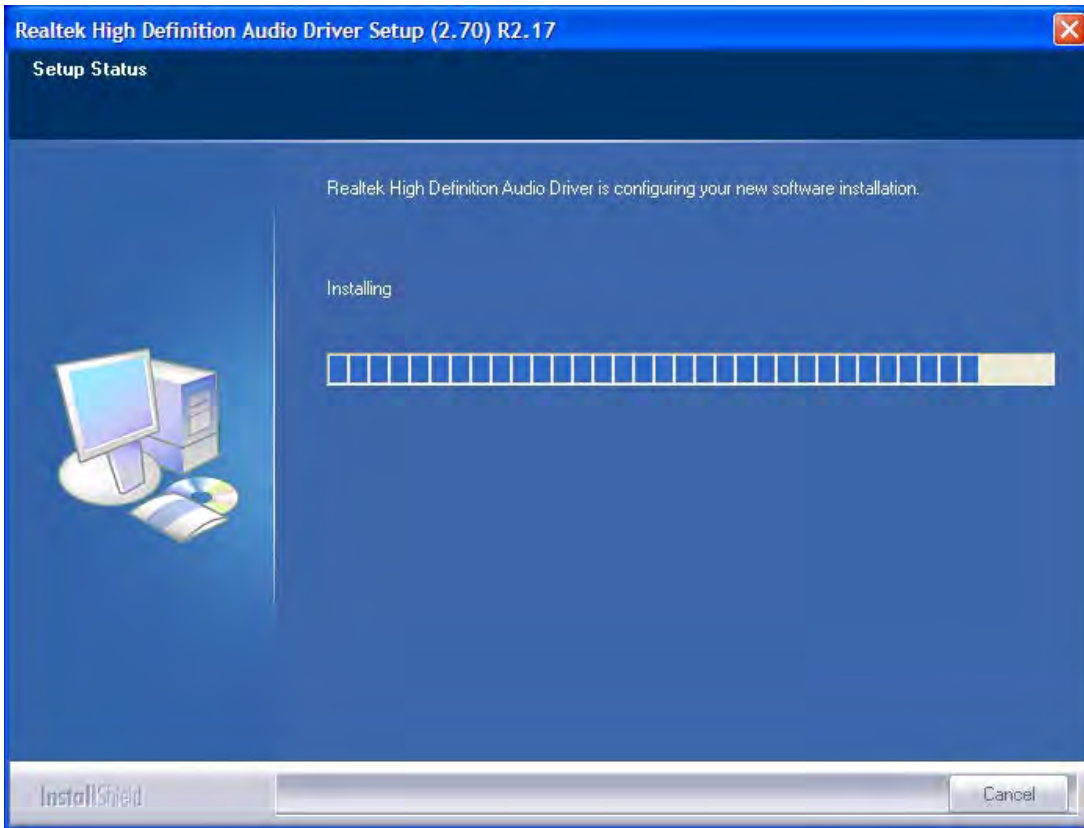

Click FINISH; A Driver Installation Complete.

## 4.5 Microsoft .NET Framework 3.5 Service Installation

To install the Microsoft .NET Framework 3.5 Service, please follow the steps below.





