



Selador Series by ETC

Lustr – Paletta – Vivid – Vivid-R – Vivid Fire – Vivid Ice – Pearl User Manual

2010-09

The Selador series of fixtures are intended for professional use only.
Read entire User Manual before using equipment.

Copyright © 2013. Electronic Theatre Controls, Inc.
All rights reserved.
Product information and specifications subject to change.
Part Number: 7400M1200 Rev G
Released: 2013-02

ACCREDITATIONS AND RECOGNITIONS (from ETL SEMKO: www.usa.etlsemko.com)

ETL SEMKO is recognized by OSHA in the U.S. as a Nationally Recognized Testing Laboratory. ETL tests to standards developed or approved by the American National Standards Institute (ANSI), Underwriters Laboratories (UL) and others. Other notable accreditations include the American Association of Laboratories Accreditations (A2LA), American National Standards Institute (ANST), International Conference of Building Officials (ICBO), and the International Electrotechnical Commission of Electrical Equipment (IECEE). ETL also has accreditations and recognitions from around the globe. Visit www.etlsemko.com/accred.html for a complete listing.

Conforms to UL Std. 1573; Certified to CSA Std. C22.2 No. 166

ETC intends this document, whether printed or electronic, to be provided in its entirety.

ETC and Selador are registered trademarks of Electronic Theatre Controls, Inc. in the United States and other countries.

Other product and company names mentioned herein may be trademarks and/or service marks of their respective owners.

This product is protected by one or more of the following U.S. Patents: 6,016,038, 6,150,774, 6,788,011, 6,806,659, 6,683,423 and 7,023,543

Table of Contents

Specifications	1
Maximum Power Consumption at Full Intensity	2
Dimensions and LEDs	3
Note About LED Fixtures.	3
Overview	4
Applications	5
Document Conventions	6
Safety	6
Installation	7
Power and Data Cabling Requirements	7
Power	7
Data	7
Installation Procedures	8
Installing Mounting Hardware	8
Installation Clearances	8
Safety Cable	10
Fixture Weight.	10
Installing Secondary Lenses.	11
Connections and Addressing	12
Control	13
Routine Maintenance	15
General Fixture Cleaning	15
Cooling Fan Filter Cleaning	16
Fuse Capacities.	16

Specifications

Note: *Vivid-R replaces the original Vivid fixture as of February 2010. The manufacturer of the K2 LED emitter is phasing out these emitters over the next year. Vivid-R maintains photometrics equivalent to the original Vivid with higher intensity and uses less power.*

Physical

- Rugged extruded anodized aluminum construction
- Advanced thermal management systems for long LED life
- 0 to 40 °C (32 to 104 °F) ambient operating temperature
- Available in 11, 21, 42, and 63 in. lengths
- (Fixtures built January 2010 and after) On-board fan speed control for no-noise operation unless in high ambient temperature situations.
- Yoke, trunnion (floor stand), or pipe-hanger mounting options
- Available in black
- See [Dimensions and LEDs, page 3](#)
- See [Fixture Weight, page 10](#)

Electrical

- 100V to 240V 50/60 Hz internal power supply
- Neutrik® PowerCon® input connector
- 5 ft power lead supplied
- Requires power from non-dim source

LEDs

- Luxeon® Rebel™ 2.5W LED emitters (Lustr, Paletta, Vivid-R, Vivid Fire, Vivid Ice, and Pearl)
- Luxeon K2 3.5W LED emitters (original Vivid fixtures manufactured January 2010 or before.)
- 50,000 hr. LED life
- See [Note About LED Fixtures, page 3](#)

Optical

- Integral 16° field angle optic (Pearl)
- Integral 17° field angle optic (Vivid-R)
- Integral 18° field angle optic (original Vivid)
- Integral 26° field angle optic (Lustr, Paletta, Vivid Fire and Vivid Ice)
- Slots for secondary lenses
- Combine secondary lenses for desired beam spread

Color

- Selador Seven-color x7 LED products for superior broad spectrum color mixing
 - Lustr – Optimized for highest output in white and light tints in a 7-color fixture
 - Paletta – Optimized for strong, saturated colors
 - Vivid, Vivid-R – Optimized for strong, saturated colors at maximum brightness
- Selador special purpose LED fixtures
 - Vivid Fire – Optimized for high-intensity saturated colors on the red end of the spectrum
 - Vivid Ice – Optimized for high-intensity saturated colors on the blue end of the spectrum
 - Pearl – High output warm and cool white LEDs for variable color temperature white (only) light output
- Interacts seamlessly with conventional sources
- Achieves excellent 3200° or any other Correlated Color Temperature white light from 800 to 20,000°K (except Vivid Fire, Vivid Ice, and Pearl)
- Beautifully illuminates skin tones and other objects
- Deeply saturated colors across an exceptionally wide gamut
- Color rendering as high as 90 CRI (except Vivid Fire, Vivid Ice, and Pearl)

Control

- DMX512-A compliant
- DMX in and thru via 5-pin XLR connectors
- 8-channel (7 color plus intensity)
- 3-channel (warm, cool, intensity) for Pearl
- Intensity channel minimizes color shift during dimming
- Digital LED display for address assignment
- Internal control electronics for smooth low-end dimming at 15-bit resolution
- 21 in. fixture provides 2 independently controllable cells
- 42 in. fixture provides 4 independently controllable cells
- 63 in. fixture provides 6 independently controllable cells^a

a) Vivid Fire and Vivid Ice are available in 11 in. and 21 in. versions only.

Maximum Power Consumption at Full Intensity

Lustr, Vivid-R, Vivid Fire, Vivid Ice, and Pearl

Model ^a	Voltage (V)	Current (A) (120V/240V)	Watts (120V/240V)
11	120/240	1.05/0.60	125W/144W
21		2.10/1.20	250W/288
42		4.20/2.40	500W/576
63		6.30/3.6	750W/864W

a) Vivid Fire and Vivid Ice are available in 11 in. and 21 in. versions only.

Paletta

Model	Voltage (V)	Current (A) (120V/240V)	Watts (120V/240V)
11	120/240	0.90/0.50	108W/120W
21		1.80/1.00	216W/240W
42		3.60/2.00	432W/480W
63		5.40/3.00	648W/720W

Vivid (Manufactured January 2010 or before)

Model	Voltage (V)	Current (A) (120V/240V)	Watts (120V/240V)
11	120/240	1.35/0.74	162W/178W
21		2.70/1.48	324W/356W
42		5.40/2.96	648W/715W
63		8.10/4.44	972W/1,068W

Dimensions and LEDs

Lustr, Vivid, Vivid-R, Vivid Fire, Vivid Ice, and Pearl

Model ^a	Size in inches	Number of LEDs
11	11.0 x 7.1 x 7.1	40
21	21.5 x 7.1 x 7.1	80
42	42.5 x 7.1 x 7.1	160
63	63.5 x 7.1 x 7.1	240

a) Vivid Fire and Vivid Ice are available in 11 in. and 21 in. versions only.

Paletta

Model	Size in inches	Number of LEDs
11	11.0 x 7.1 x 6.25	40
21	21.5 x 7.1 x 6.25	80
42	42.5 x 7.1 x 6.25	160
63	63.5 x 7.1 x 6.25	240

Note About LED Fixtures

All LED sources experience some lessening of light output and some color shift over time. Selador Series fixtures have complex thermal management systems to minimize these changes. With typical usage, a Selador fixture will still achieve 70% of its initial output after 50,000 hours of use. In individual situations, LEDs will be used for different durations and different levels. This can eventually lead to minor alterations in color performance, necessitating slight adjustment to presets, cues, or programs.

All LEDs exhibit a slight color shift as their temperature rises from ambient to operating temperature. This may or may not be visible to the eye. If this is a concern, a five to ten minute warm up cue (all color channels at 100%, intensity channels at 50%) prior to production can minimize this effect.

Overview

Congratulations on your purchase of a *Selador Series by ETC* product.

Selador's x7 Color System™ seven-hue technology produces a light and color quality that conventional LED systems cannot duplicate. This unique color system produces bright, broad-spectrum whites and intense colors equally well, rendering pigments, objects, and skin tones in a natural way. Vivid Fire and Vivid Ice fixtures use elements of the x7 Color System for superior performance in deep saturated colors.

Each member of the Selador Series product line is unique and optimized for a specific lighting task:

Lustr

- Luxeon Rebel 2.5W LED emitters
- Full 7-color x7 LED array
- Broad spectrum color optimized for the best white and light tints in a 7-color fixture across the entire CCT range
- Beautifully illuminates skin tones and other objects

Paletta

- Luxeon Rebel 2.5W LED emitters
- Full 7-color x7 LED array
- Optimized for deep, pure pastels and saturated colors in a lower profile and affordable fixture
- Interacts seamlessly with conventional sources

Vivid-R

- Luxeon Rebel 2.5W LED emitters
- Full 7-color x7 LED array
- Optimized for high-output deep pastels and strong saturated colors
- Narrow optics for the longest throws

Vivid Fire

- Luxeon Rebel 2.5W LED emitters
- Specialized LED array
- Optimized for saturated colors at the red end of the spectrum
- Strong output for high-intensity theatrical environments

Vivid Ice

- Luxeon Rebel 2.5W LED emitters
- Specialized LED array
- Optimized for saturated colors at the blue end of the spectrum
- Strong output for high-intensity theatrical environments

Pearl

- Luxeon Rebel 2.5W LED emitters
- Specialized LED array
- High output warm and cool white LEDs for variable color temperature white (only) light output from 3200 to 5700K.

Information in this manual is applicable to all *Selador Series by ETC* products.

Applications

- Theaters
- Studios
- Churches
- Hotels
- Convention Centers
- Schools

Application	11 in.	21 in.	42 in.	63 in.
Truss warmer	•			
Front light	•	•		
Side light	•	•		
Key light	•	•		
Fill light	•	•	•	
Specials	•	•		
Downlight	•	•	•	•
Backlight	•	•	•	•
Stagewash	•	•	•	•
Cyc light	•	•	•	•

If you have questions about your Selador series fixture that are not answered in this manual, please contact the supplier of your ETC equipment or ETC Technical Services.

Americas

Electronic Theatre Controls Inc.
 Technical Services Department
 3031 Pleasant View Road
 Middleton, WI 53562
 800-775-4382 (USA, toll-free)
 +1-608 831-4116
 service@etcconnect.com

United Kingdom

Electronic Theatre Controls Ltd.
 Technical Services Department
 26-28 Victoria Industrial Estate
 Victoria Road,
 London W3 6UU England
 +44 (0)20 8896 1000
 service@etc europe.com

Asia

Electronic Theatre Controls Asia, Ltd.
 Technical Services Department
 Room 1801, 18/F
 Tower 1, Phase 1 Enterprise Square
 9 Sheung Yuet Road
 Kowloon Bay, Kowloon, Hong Kong
 +852 2799 1220
 service@etcasia.com

Germany

Electronic Theatre Controls GmbH
 Technical Services Department
 Ohmstrasse 3
 83607 Holzkirchen, Germany
 +49 (80 24) 47 00-0
 techserv-hoki@etcconnect.com

Please email comments about this manual to: TechComm@etcconnect.com

Document Conventions

Throughout this manual, the following are used to alert you to notes and safety notices.



Note: *Notes are helpful hints and information that is supplemental to the main text.*



CAUTION: *A Caution statement indicates situations where there may be undefined or unwanted consequences of an action, potential for data loss or an equipment problem.*



WARNING: *A Warning statement indicates situations where damage may occur, people may be harmed, or there are serious or dangerous consequences of an action.*



WARNING: ***RISK OF ELECTRIC SHOCK!** This warning statement indicates situations where there is a risk of electric shock.*

Safety

The Selador series fixtures are intended for professional use only. **Read entire User Manual before using equipment.**

Please note the following safety notices before use:



WARNING: *Note the following safety warnings before use:*

- Do not mount the Selador series fixture on or near a flammable surface.
 - Use the fixture in dry locations only, where humidity does not exceed 90 percent (non-condensing). Fixture is not intended for outdoor use.
 - Mount and support the fixture only by the primary suspension holes in the enclosure.
 - Suspend the fixture from a suitable structure using only the hardware rated for the weight of the fixture.
 - In addition to primary suspension, attach a safety cable (ETC Model 400SC or other approved safety cable or device) to the fixture housing. Appropriate attachment points (holes) are provided in the protruding tabs on either end of the fixture housing.
 - Disconnect the unit from power and from DMX before all cleaning and maintenance.
 - Maximum ambient temperature: $T_a=40^{\circ}\text{C}$ (104°F)
 - Maximum exterior surface temperature: $T_{\text{max}}=80^{\circ}\text{C}$ (158°F)
 - External Temperature after 5 minutes of full-brightness operation and 23°C (74°F) ambient: 38°C (100°F)
 - External Temperature (steady state achieved) at 23°C (74°F): 70°C (158°F)
-

Installation

Power and Data Cabling Requirements

Power

The Selador series fixture operates on AC power, 100 to 240VAC/50-60Hz. You may use a circuit powered through an SCR dimmer, as long as the dimmer is set to unregulated non-dim (switched) operation.

Power is supplied through a standard five-foot power-input cable with Neutrik PowerCon locking pigtail with either an Edison, Twistlock™, or Stage-pin male connector.

Data

The Selador series fixtures operate on a DMX control signal. The unit is supplied with a 5-pin XLR DMX input connector and a 5-pin DMX Thru connector. DMX cables should be acceptable for DMX data transmission (not microphone cable) and should follow the standard pinout. The optional secondary data pair is not used by the Selador series fixtures. The maximum DMX data run from any DMX source to the last fixture in a chain is 1000 feet (300m). Termination is required in the data thru port of the last fixture in each data chain.

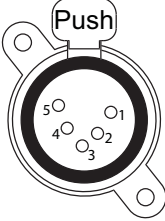
DMX512 pinout for five-pin XLR female		
	1	Common (Shield)
	2	Data -
	3	Data +
	4	not connected
	5	not connected

See [Control, page 13](#) for additional information on DMX addressing of Selador Series fixtures.

Installation Procedures

Installing Mounting Hardware

Four different options are available for mounting Selador fixtures.

- Yoke with C-clamp for 11 and 21 in. units
- Double yoke with C-clamp for two 11 or two 21 in. fixtures (over/under configuration)
- Floor trunnions for all fixtures
- Pipe hanging brackets for all fixtures



Note: *Trunnions should be installed with the feet inward so that fixtures can be lined up end to end if needed.*

Installation Clearances

Cooling and Duty Cycle

Selador Series fixtures are equipped with ultra-quiet cooling fans. These fans are automatically controlled. They permit fan-free operation when possible and turn on only when needed to provide low-noise, predictable service for extended periods of time in ambient temperatures up to 104°F (40°C). When the fan turns on, its speed ramps up slowly in order to minimize the noise differential.



CAUTION: *Duty Cycle*

Operating the fixtures in higher ambient temperatures or low airflow situations may cause the power supply to shut down. Following a cool down period, the power supply will automatically reset and the fixture will return to operation.

It is good practice to power down any device with on-board electronics to limit unnecessary wear on the devices and eliminate residual use of electricity. When not in use, Selador fixtures should be powered down by disconnecting from power either at the breaker or by unplugging.

LED life is adversely affected by high temperature operation. Whenever possible, avoid turning all channels to 100% for extended periods, such as channel checks or focusing.

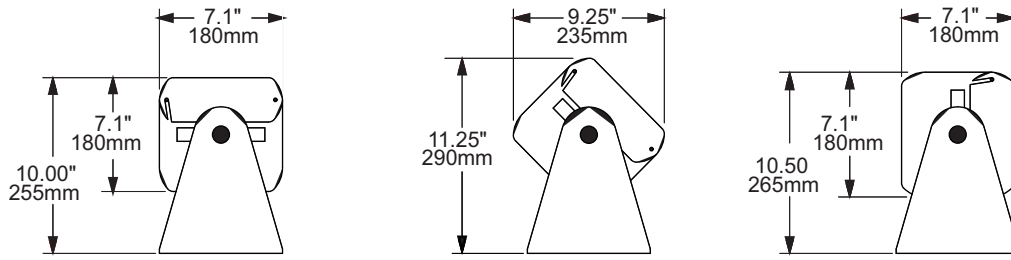

Floor trunion dimensions

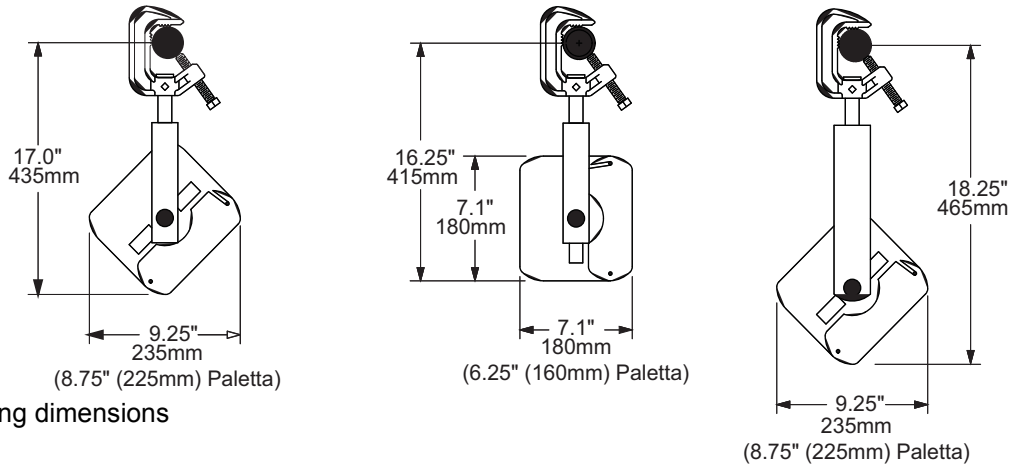

Hanging dimensions

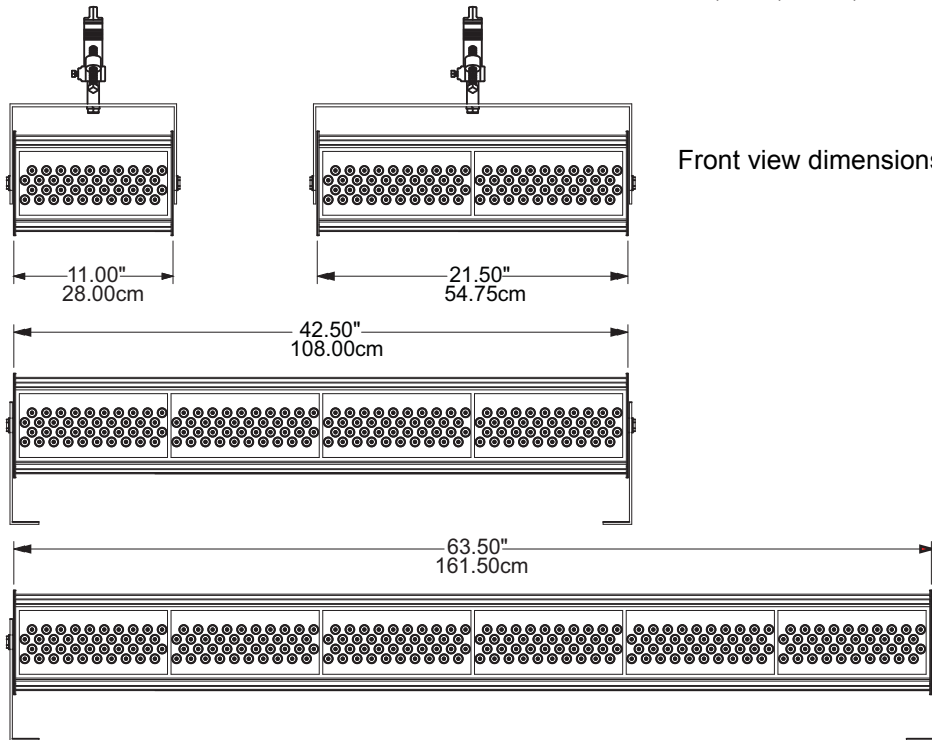

Front view dimensions

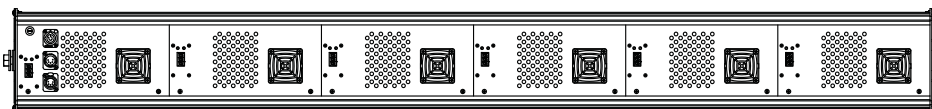

Rear view to show power, data connections, and repeating addressing and fan locations

Safety Cable

The safety cable (or other approved safety device) should be attached to the fixture housing and wrapped around the hanging structure (pipe). Appropriate attachment points (holes) are provided in the protruding tabs on either end of the fixture housing. Take care to leave as little slack as possible in the safety cable to avoid the cable catching the yoke of the fixture.

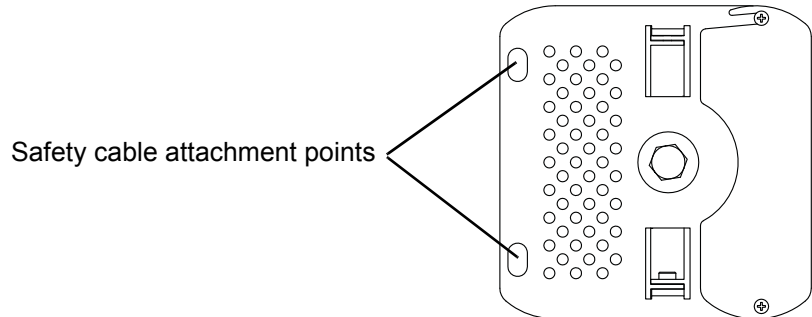

Fixture Weight

Total weight depends on how the individual fixture is configured. Weights shown do not include secondary lenses.

Lustr, Vivid -R, Vivid Fire, Vivid Ice, and Pearl

Model	Weight ^a		Shipping Weight	
	Lbs.	Kg.	Lbs.	Kg.
11	11.5	5.2	15	6.9
21	20	9.1	25	11.4
42	35	15.9	42	19.1
63	53	24.1	62	28.2

a) Does not include mounting hardware.

Paletta

Model	Weight ^a		Shipping Weight	
	Lbs.	Kg.	Lbs.	Kg.
11	10.5	4.7	14	6.4
21	18	8.2	23	10.5
42	32	14.6	39	17.7
63	48.6	22.1	58	26.4

a) Does not include mounting hardware.

Installing Secondary Lenses

Up to two secondary lenses can be installed in the slots towards the front of the fixture. The stacking order and distance from the LED array are not important to the function of the lenses. To avoid lenses being too loose and potentially overlapping each other, use the narrower slots for thinner lenses.

To install secondary lenses:

Step 1: Loosen the screw on the end of the access panel that has the slot in it.

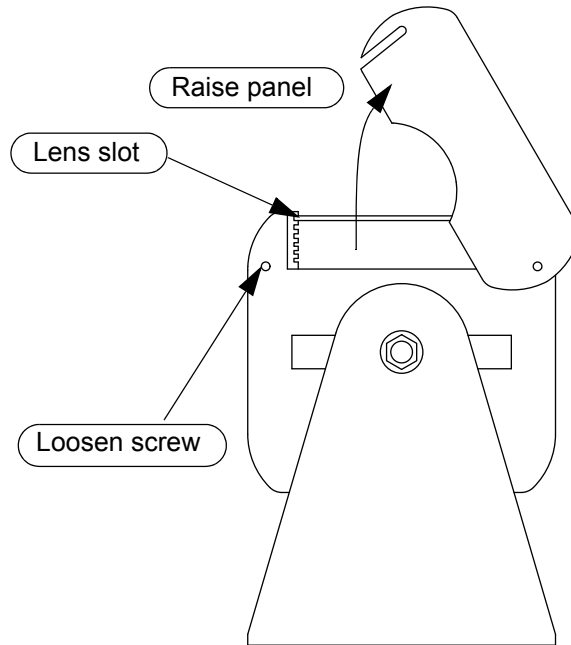

Step 2: Raise the panel out of the way, but leave it attached to the fixture.

Step 3: Slide the secondary lenses into the slots above the LEDs.

Step 4: Lower the panel and tighten the screw.

Connections and Addressing

Connect AC input power and DMX data cables to the appropriate ports as shown below. The Paletta connectors are located slightly differently than shown in the illustration below. However, the descriptions and functions described below are the same.

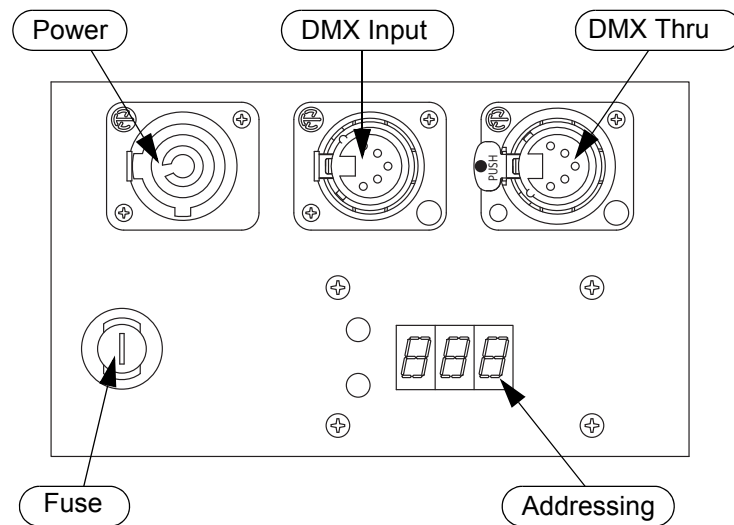

Connect the incoming DMX data cable to the DMX Input connector. If you are daisy-chaining the data to other fixtures or DMX-controlled devices, connect the next DMX cable to the DMX Thru connector. The Selador Series fixtures require that the last fixture on a DMX line be terminated with a 100Ω resistor between pins 2 and 3.

Connect the AC Input cable:

Align and insert the power connector. Twist the connector clockwise until it locks into place.

Note: Upon power up, the software version is briefly displayed, then the current DMX address setting is displayed.

Disconnect the AC Input cable:

Slide back the locking tab, twist the connector counterclockwise and pull to unlock and disconnect the power connector.

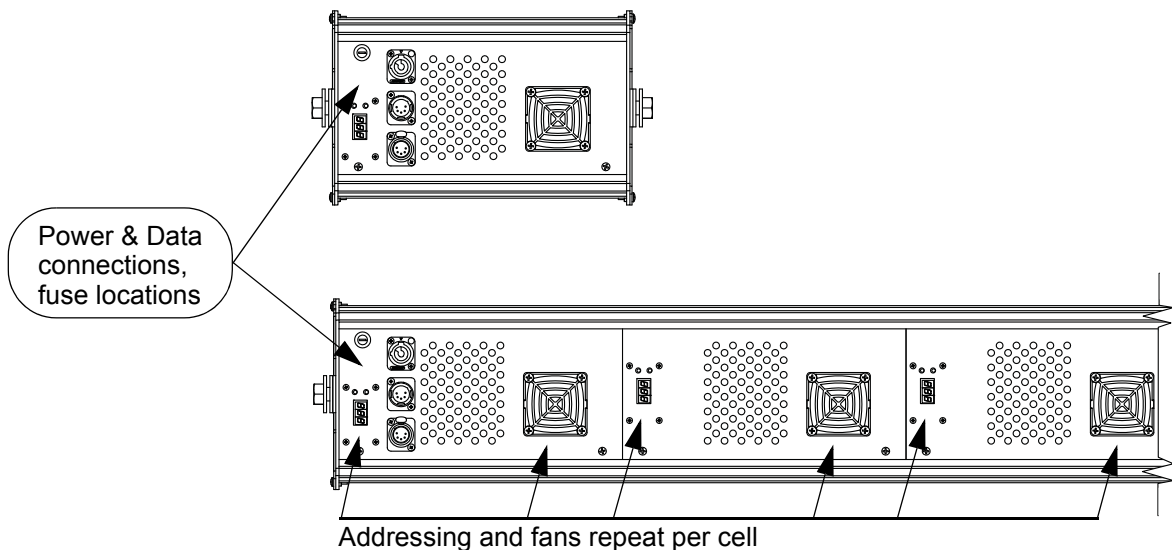

Fuse

The quarter-turn fuse-holder requires a straight blade screwdriver to remove and reinstall a fuse. Refer to [Fuse Capacities, page 16](#) for information about fuse types.

Control

Use the two push buttons on the bottom of the fixture to set the starting address for the fixture. View the LED display with the push buttons on the left. The top push button increases the number and the bottom push button decreases the number. Pressing and holding the push button increases the rate of change. **When fixtures are powered up, they may temporarily respond to DMX address 001 for the first few seconds of operation.** New address settings take effect after the LED display turns off.



CAUTION: *Do not push the up and down address buttons simultaneously, or internal fixture software settings can be inadvertently compromised and performance affected.*

Up and down address buttons are recessed to avoid inadvertent address changes. Use a Phillips screwdriver or other blunt device to lightly push the switches. To avoid damaging the switches, do not use sharp objects or excessive force when changing fixture address.

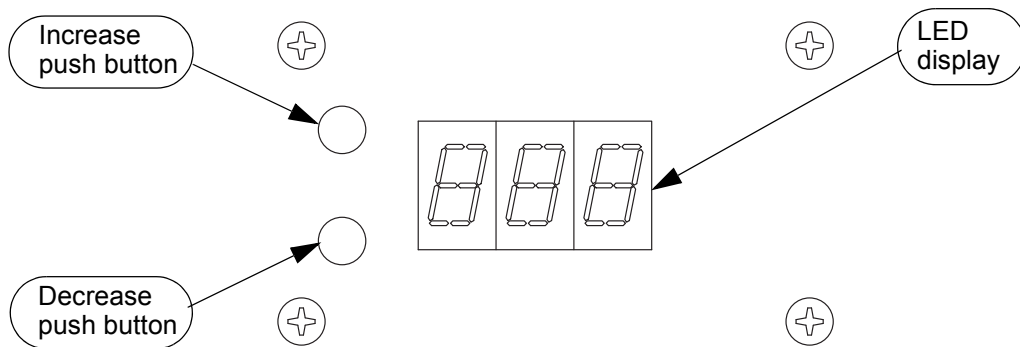

Addresses must be set between 1 and 505. Selador fixtures are manufactured based on an 11 in. LED array, or cell. Each cell can be addressed individually. Eleven inch fixtures have one cell, 21 in. fixtures have two cells, 42 in. fixtures have four cells, and 63 in. fixtures have six cells. A 42 in. fixture can be addressed as four individual cells, one cell, or any combination.

Each Selador fixture must be considered a separate DMX device for the purpose of DMX line-loading calculations, with the exception of 63" fixtures. These 63" fixtures must each be considered 1.5 DMX devices for line loading.

Fixture	Number of Cells	Number of DMX Devices
11 in.	1	1
21 in.	2	1
42 in.	4	1
63 in.	6	1.5

DMX line-loading practice dictates that no more than 31 devices can be daisy-chained together. Consequently, no combination of Selador fixtures totaling more than 31 DMX devices should be configured in one DMX line. For example, twenty 6-cell units (30 DMX devices) are okay. Twenty-one 6-cell units (31.5 DMX devices) are not acceptable. For runs of fixtures totaling more than 31 DMX devices, split the DMX runs by using a DMX splitter.



Note: *A fixture with a starting address higher than 505 will not have control of all parameters. Therefore, 505 is the highest address shown on the address display.*

Each cell of a Selador Series fixture (except Pearl) occupies eight DMX channels. Seven are individual colors and the eighth is the master intensity. The table below describes the order and function of each address.

Lustr, Paletta, and Vivid-R

	Data Channel	Color	Value	Function
1	Fixture address	Red	0-255	Intensity 0-100%
2	Fixture address + 1	Red-orange	0-255	Intensity 0-100%
3	Fixture address + 2	Amber	0-255	Intensity 0-100%
4	Fixture address + 3	Green	0-255	Intensity 0-100%
5	Fixture address + 4	Cyan	0-255	Intensity 0-100%
6	Fixture address + 5	Blue	0-255	Intensity 0-100%
7	Fixture address + 6	Indigo	0-255	Intensity 0-100%
8	Fixture address + 7	Master intensity control	0-255	Overall intensity 0-100%

Vivid Fire

	Data Channel	Color	Value	Function
1	Fixture address	Red	0-255	Intensity 0-100%
2	Fixture address + 1	Red-orange	0-255	Intensity 0-100%
3	Fixture address + 2	Amber	0-255	Intensity 0-100%
4	Fixture address + 3	Green	0-255	Intensity 0-100%
5	Fixture address + 4	Not used	—	—
6	Fixture address + 5	Not used	—	—
7	Fixture address + 6	Indigo	0-255	Intensity 0-100%
8	Fixture address + 7	Master intensity control	0-255	Overall intensity 0-100%

Vivid Ice

	Data Channel	Color	Value	Function
1	Fixture address	Red	0-255	Intensity 0-100%
2	Fixture address + 1	Not used	—	—
3	Fixture address + 2	Not used	—	—
4	Fixture address + 3	Green	0-255	Intensity 0-100%
5	Fixture address + 4	Cyan	0-255	Intensity 0-100%
6	Fixture address + 5	Blue	0-255	Intensity 0-100%
7	Fixture address + 6	Indigo	0-255	Intensity 0-100%
8	Fixture address + 7	Master intensity control	0-255	Overall intensity 0-100%

Pearl

	Data Channel	Color	Value	Function
1	Fixture address	Warm white (3200K)	0-255	Intensity 0-100%
2	Fixture address + 1	Cool white (5700K)	0-255	Intensity 0-100%
3	Fixture address + 2	Master intensity control	0-255	Intensity 0-100%



Note: Use individual color channels to create color mix. Use Master Intensity Control to set fixture intensity. Master Intensity Control (Channel 8) must be above 0% for the fixture to output.

Routine Maintenance

General Fixture Cleaning

To ensure optimum performance of your Selador series fixture, you should perform the following inspections and cleanings at least once a year. You may need to inspect or clean the fixture more often, depending on the type and amount of use your fixture experiences during the year.



CAUTION: *Allow fixture to cool down completely prior to cleaning.*

Disconnect all power and DMX cables prior to cleaning.

Check for excessive dust or debris in the heat-dissipating fins around the entire fixture enclosure. Clean using compressed air or a soft cloth. Keeping the heat sink components of the enclosure clean facilitates efficient cooling and extends LED longevity.

NEVER spray liquids into the fixture.

NEVER spray compressed air into a fixture that is powered-up.

- A can of compressed air or oil-free air from an air compressor set at a low setting can be used to blow through the vent holes and remove dust or other debris from the interior of the fixture. Dust build-up can cause overheating and premature shutdown.
- Remove the secondary lenses (if used) and clean out any dust and debris. All components, including the secondary lenses, can be cleaned using compressed, oil-free air as described above or a clean micro-fiber cloth. The use of any liquid cleaning solution is not recommended for Selador fixtures.
- Inspect all mounting hardware for wear and, if necessary, clean using compressed, oil-free air or a soft, lint-free cloth.

Cooling Fan Filter Cleaning

- ❑ Cooling fan filters should be inspected at a minimum every six months; more frequently if fixtures are powered on for more than four hours per day.
- ❑ Use a vacuum cleaner to remove dust from each fan filter.
- ❑ In dusty environments or conditions involving the use of smoke machines, clean the filters as follows:
 - Using fingernail or small flat-blade screwdriver, remove fan filter cover by prying under one of the two locking tabs.
 - Carefully remove foam fan filter from fan assembly.
 - Gently wash foam fan filter in a solution of mild dishwashing solution and water.
 - Thoroughly rinse each foam fan filter in clear water.
 - Pat dry or air-dry filters.
 - After filters are completely dry, reinstall by inserting them into fan assembly.
 - Reattach the fan filter cover to the fixture.



Note: *No user-serviceable parts are inside.*

Fuse Capacities

All Selador Fixtures use 3AG 250V 1.25" X 0.25" fuses. Use the following capacity fuses for all Selador fixtures.

Fixture Size	Fuse Value
11 in.	2 amp
21 in.	4 amp
42 in.	8 amp
63 in.	10 amp



Corporate Headquarters ■ 3031 Pleasant View Road, P.O. Box 620979, Middleton, Wisconsin 53562-0979 USA ■ Tel +608 831 4116 ■ Fax +608 836 1736
London, UK ■ Unit 26-28, Victoria Industrial Estate, Victoria Road, London W3 6UU, UK ■ Tel +44 (0)20 8896 1000 ■ Fax +44 (0)20 8896 2000
Rome, IT ■ Via Pieve Torina, 48, 00156 Rome, Italy ■ Tel +39 (06) 32 111 683 ■ Fax +44 (0) 20 8752 8486
Holzkirchen, DE ■ Ohmstrasse 3, 83607 Holzkirchen, Germany ■ Tel +49 (80 24) 47 00-0 ■ Fax +49 (80 24) 47 00-3 00
Hong Kong ■ Rm 1801, 18/F, Tower 1 Phase 1, Enterprise Square, 9 Sheung Yuet Road, Kowloon Bay, Kowloon, Hong Kong ■ Tel +852 2799 1220 ■ Fax +852 2799 9325
Service: (Americas) service@etconnect.com ■ (UK) service@etceurope.com ■ (DE) techserv-hoki@etconnect.com ■ (Asia) service@etcasia.com
Web: www.etconnect.com ■ Copyright © 2013 ETC. All Rights Reserved. ■ Product information and specifications subject to change.
7400M1200 ■ Rev G ■ Released 2013-02