





Models DPC-9T and DPC-11T



In accordance with Nexen's established policy of constant product improvement, the specifications contained in this manual are subject to change without notice. Technical data listed in this manual are based on the latest information available at the time of printing and are also subject to change without notice.

Technical Support: 800-843-7445
(651) 484-5900

www.nexengroup.com

	<p style="text-align: center;"> DANGER</p> <p>Read this manual carefully before installation and operation. Follow Nexen's instructions and integrate this unit into your system with care. This unit should be installed, operated and maintained by qualified personnel ONLY. Improper installation can damage your system, cause injury or death. Comply with all applicable codes.</p>	
---	---	---

This document is the original, non-translated, version.

Conformity Declaration: In accordance with Appendix II B of CE Machinery Directive (2006/42/EC):

A Declaration of Incorporation of Partly Completed Machinery evaluation for the applicable EU directives was carried out for this product in accordance with the Machinery Directive. The declaration of incorporation is set out in writing in a separate document and can be requested if required.

This machinery is incomplete and must not be put into service until the machinery into which it is to be incorporated has been declared in conformity with the applicable provisions of the Directive.

Nexen Group, Inc.
560 Oak Grove Parkway
Vadnais Heights, Minnesota 55127

ISO 9001 Certified

Copyright 2014 Nexen Group, Inc.

TABLE OF CONTENTS

- General Specifications 1
- General Safety Precautions1
- Introduction2
- Installation2
 - Support Bushing2
 - Pilot Mount Clutch3
 - Sheave Mount4
- Lubrication4
- Air Connections5
 - Shaft End Mounting5
 - Through Shaft Mounting6
- Operation7
- Parts Replacement8
 - Friction Facing8
 - O-rings9
 - Bearings9
- Replacement Parts11
- Warranty12

GENERAL SPECIFICATIONS

Specifications	
Torque	Up to 1243 Nm (11000 in-lbs)
Actuation Pressure	1 - 5.5 bar (14.5 - 80 psi)
Service Temperature	4.5° - 104° C (40° - 220° F)
Approximate Weight	Up to 45.5 kg (100 lbs)

GENERAL SAFETY PRECAUTIONS



CAUTION

Use appropriate guarding for moving components. Failure to guard could result in serious bodily injury.



CAUTION

Use lifting aids and proper lifting techniques when installing, removing or placing this product in service.



CAUTION

Watch for sharp features when interacting with this product. The parts have complex shapes and machined edges.



WARNING

This product is capable of emitting a spark if misused, therefore is not recommended for use in any explosive environment.



CAUTION

This product has possible pinch points. Care should be taken when interacting with this product.



WARNING

Ensure proper guarding of the product is used. Nexen recommends the machine builder design guarding in compliance with OSHA 29 CFR 1910 "Occupational Safety and Health Hazards."

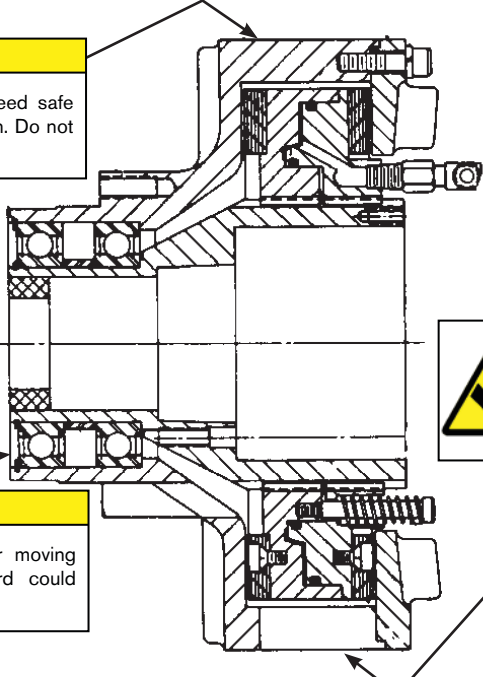



CAUTION

Surface temperature may exceed safe handling limits during operation. Do not touch.



CAUTION

Use appropriate guarding for moving components. Failure to guard could result in serious bodily injury.



CAUTION

This product has possible pinch points. Care should be taken when interacting with this product.

INTRODUCTION

Nexen's DPC (*Dual Friction Plate*) Clutches are designed to mount on shaft ends, or through shafts using a customer supplied Q.D. (*Quick Detachable*) Bushing. The dual friction plate design eliminates thrust loading of bearings when the DPC Clutch is connected to a bearing supported Flywheel, Sprocket, or Sheave.

Five components are combined to install Nexen's DPC Clutch, and a Pilot Mount Clutch, or as a Sheave Clutch.

The five basic components (each sold separately) are: Pilot Clutch Assembly, Sheave, Rotary Air Union Cap, Q. D. Bushing, and Rotary Air Union.

The inner and outer assemblies of the DPC Clutch rotate independently.

When mounted on a through shaft, the outer clutch assembly rotates, and upon engagement, the inner clutch assembly becomes the driven unit.

When mounted on a continually running shaft, the inner clutch assembly rotates, and upon engagement, the outer clutch assembly becomes the driven member.

Nexen recommends mounting the DPC Clutch with the outer clutch assembly rotating continuously; taking advantage of the cooling effect of the fins to dissipate heat generated when the clutch is engaged.

INSTALLATION

NOTE

All DPC Clutch installations require a Q.D. (Quick Detachable) Bushing. Refer to Table 1 for Q. D. Bushing Specifications.

TABLE 1 Q.D. Bushing Specifications

Model	Bushing Type	Bore	Pull-up Bolt Tightening Torque
DPC-9T	SK	2.375	15 ft-lbs [20 Nm]
DPT-11T	SF	2.875	10 ft-lbs [41 Nm]

SUPPORT BUSHING

NOTE

The Support Bushing provides radial load support at the shaft, and is used when bore sizes smaller than standard are required.

REFER TO FIGURE 1.

1. Place "DPC" Clutch, Friction Disc side down, and support large end of Splined Hub (Item 1).
2. Insert Support Bushing into bore of Splined Hub (Item 1).
3. Apply even pressure around the entire diameter of the Support Bushing, and press the Support Bushing into the Splined Hub (Item 1).

NOTE

Do not use a hammer to install Support Bushing. Nexen recommends a small arbor press.

NOTE

On "DPC-9T" the Support Bushing fits flush with the end of the Splined Hub.

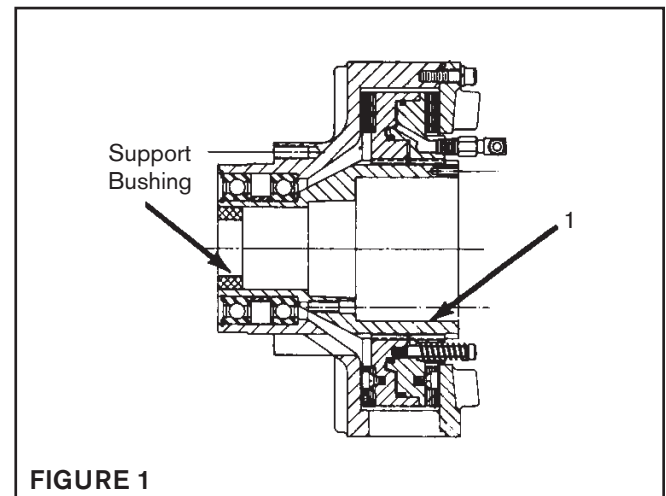

FIGURE 1

INSTALLATION (continued)

PILOT MOUNT CLUTCH

REFER TO FIGURE 2.

1. Install Support Bushing if required.
2. Thoroughly inspect tapered bore of the Splined Hub and tapered surface of the Q. D. Bushing. Remove any dirt, grease, or foreign material.

NOTE

Do not use lubricants when installing the Q.D. Bushing.

3. Install Q. D. Bushing into Splined Hub, aligning untapped holes on Q. D. Bushing Flange with tapped holes in Splined Hub.

NOTE

Do not strike Q. D. Bushing to "SET" it in the tapered bore.

4. Loosely insert Pull-Up Bolts and Lockwashers into Q. D. Bushing, and tapped holes of Splined Hub.

NOTE

Do not use lubricants or thread locking compounds on Pull-Up Bolts.

5. Measure runout of Motor Shaft. Runout must not exceed 0.002 T.I.R. (Total Indicator Reading)
6. Insert Key into Motor Shaft Keyway.
7. Slide "DPC" Clutch onto Motor Shaft.
8. Alternately, and evenly tighten Pull-Up Bolts to recommended torque (See Table 1).

NOTE

Do not over tighten Pull-Up Bolts. If excessive tightening torque is applied, bursting pressure is created in the Splined Hub.

NOTE

Runout is minimized if a Dial Indicator is used as the Q. D. Bushing Pull-Up Bolts are tightened. Place contact tip of Dial Indicator on the machined surface of the Splined Hub to measure runout. Runout on this surface must be within 0.003 T.I.R. when the Pull-Up Bolts are tightened.

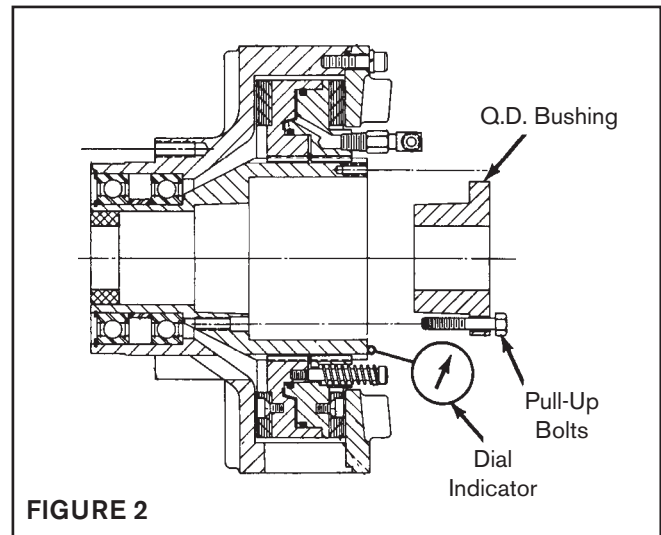

INSTALLATION (continued)

SHEAVE MOUNT

NOTE

The Sheave Clutch is a combination of the Pilot Clutch and Sheave Assembly (both shipped in a separate container).

REFER TO FIGURE 3.

1. Slide the Sheave (Item 26) onto the pilot diameter of the Pilot Clutch Assembly.
2. Align the mounting holes in the Sheave (Item 26) with the tapped holes in the Housing (Item 5).
3. Install the Cap Screws (Item 28), and Lockwashers (Item 27).
4. Tighten the Cap Screws (Item 28) to the recommended torque (See Table 2).
5. Proceed with Steps 1 through 8 from Pilot Mount Clutch Installation section on the previous page.

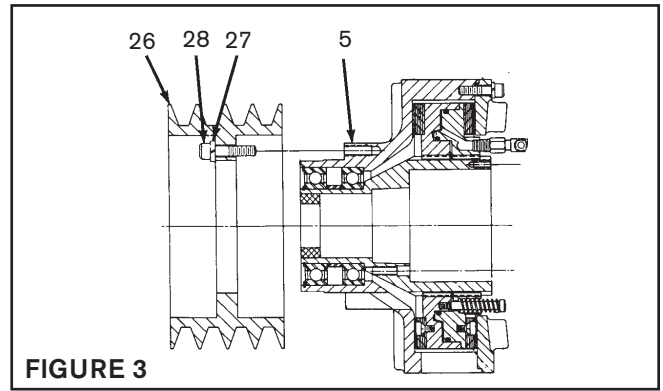

FIGURE 3

TABLE 2 Recommended Tightening Torques

Description	DPC-9T	DPC-11T
Shoulder Screw (Item 12)	9 ft-lbs [12 Nm]	9 ft-lbs [12 Nm]
Cap Screw (Item 15)	48 ft-lbs [65 Nm]	48 ft-lbs [65 Nm]
Cap Screw (Item 24)	13 ft-lbs [18 Nm]	13 ft-lbs [18 Nm]
Cap Screw (Item 28)	48 ft-lbs [65 Nm]	48 ft-lbs [65 Nm]

LUBRICATION

NOTE

Nexen pneumatically actuated devices require clean, pressure regulated air for maximum performance and life. All seals in Nexen pneumatically operated devices are lubricated for life, and do not require additional lubrication.

However, some customers prefer to use an air line lubricator, which injects oil into the pressurized air, forcing an oil mist into the air chamber. This is acceptable, but care must be taken to ensure once an air mist lubrication system is used, it is continually used over the life of the product as the oil mist may wash free the factory installed lubrication.

Locate the lubricator above and within ten feet of the product, and use low viscosity oil such as SAE-10.

Synthetic lubricants are not recommended.

Nexen product's bearings are shielded and pre-lubricated, and require no further lubrication.

LUBRICATOR DRIP RATE SETTINGS



CAUTION

These settings are for Nexen supplied lubricators. If you are not using a Nexen lubricator, calibration must follow the manufacturer's suggested procedure.

1. Close and disconnect the air line from the unit.
2. Turn the Lubricator Adjustment Knob counterclockwise three complete turns.
3. Open the air line.
4. Close the air line to the unit when a drop of oil forms in the Lubricator Sight Gage.
5. Connect the air line to the unit.
6. Turn the Lubricator Adjustment Knob clockwise until closed.
7. Turn the Lubricator Adjustment Knob counterclockwise one-third turn.
8. Open the air line to the unit.

ROTARY AIR UNION LUBRICATION

Rotary air unions have an oil reservoir. This reservoir must be re-filled monthly under normal operation, or weekly under high speed operation. Use 4 to 5 drops of high quality motor oil only.

AIR CONNECTIONS

All Nexen pneumatically actuated devices require clean and dry air, which meets or exceeds ISO 8573.1:2001 Class 4.4.3 quality.

NOTE

For quick response, Nexen recommends a quick exhaust valve and short air lines between the Control Valves and the unit. Align the air inlet ports to a down position to allow condensation to drain out of the air chambers of the product.



CAUTION

Low air pressure will cause slippage and overheating. Excessive air pressure will cause abrupt starts and stops, reducing product life.

The following are common air supply schemes used with this product. These are examples and not an all-inclusive list. All air circuits to be used with this product must be designed following ISO 4414 guidelines.

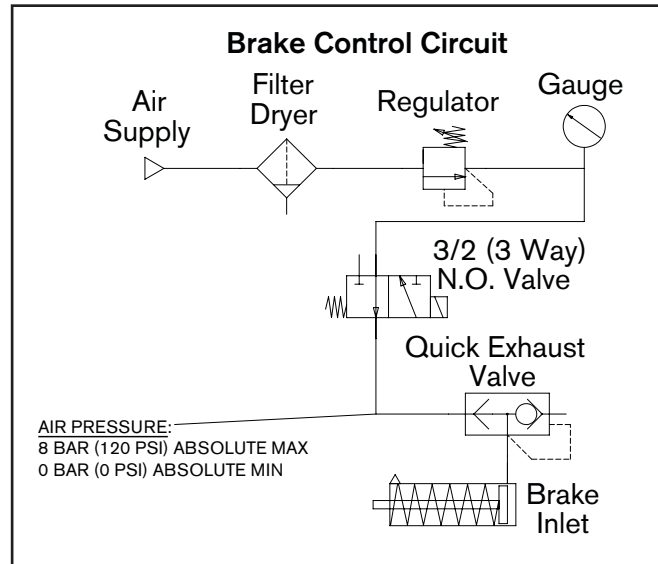

SHAFT END MOUNTING

REFER TO FIGURE 4.

1. Install two Elbow Fittings (Item 20) into the Rotary Air Union Cap (Item 25).
2. Install an Adaptor Fitting (Item 19) and Elbow Fitting (Item 20) into each air inlet of the Piston/Drive Disc (Item 2).
3. Using Cap Screws (Item 24), attach the Rotary Air Union Cap (Item 25) to the tapped holes of the Splined Hub (Item 1).

NOTE

The Rotary Air Union Cap air outlets must be aligned at approximately 60° to the Piston/Drive Disc air inlets for proper Hose (Item 22) connection.

4. Tighten the Cap Screws (Item 24) to the recommended torque (See Table 3).
5. Install Hoses (Item 22).
6. Install the Rotary Air Union (Item 21).
7. Connect air supply to the Rotary Air Union.

NOTE

Do not use rigid pipe or tubing for this connection. For fast engagement and disengagement, connect air controls as close to the DPC Clutch as possible. Where long air lines are required, use a quick exhaust valve.

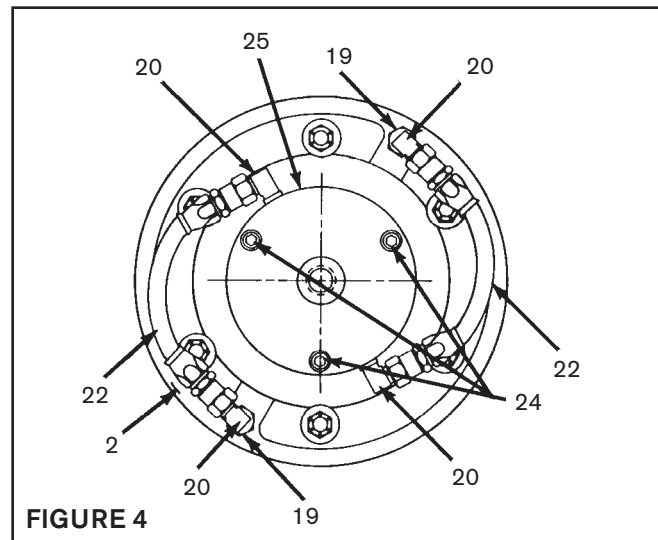

FIGURE 4

TABLE 3 Recommended Tightening Torques

Description	DPC-9T	DPC-11T
Cap Screw (Item 24)	13 ft-lbs [18 Nm]	13 ft-lbs [18 Nm]

AIR CONNECTIONS (continued)

THROUGH SHAFT MOUNTING

REFER TO FIGURE 5.

1. Drill a 3/8" diameter hole into the center of the shaft; deep enough to reach the desired air outlets.

NOTE

Air outlets should be approximately 3/8" from the end of the Hub.

2. Tap the end of the Shaft 5/8–18 by 5/8" deep.
3. Drill a 1 1/32" diameter air outlet hole through the shaft; intersecting the air inlet hole approximately 3/8" from the end of the Hub.
4. Tap both air outlet holes 1/8–27 NPT by 5/8" deep.
5. Install two Elbow Fittings (Item 20) into each air outlet hole.
6. Install an Adaptor Fitting (Item 19) and Elbow Fitting (Item 20) into each air inlet of the Piston/Drive Disc (Item 2).
7. Install Hoses (Item 22).
8. Install the Rotary Air Union (Item 21).
9. Connect air supply to the Rotary Air Union.

NOTE

Do not use rigid pipe or tubing for this connection. For fast engagement and disengagement, connect air controls as close to the "DPC" Clutch as possible. Where long air lines are required, use a quick exhaust valve.

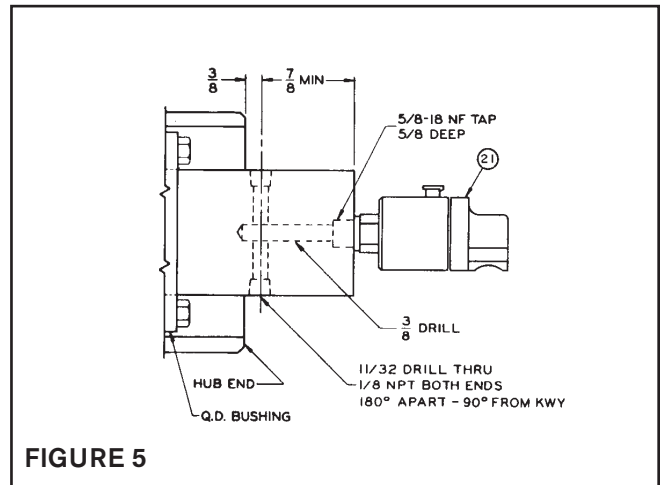





FIGURE 5

OPERATION

	CAUTION
	The temperature limits for this product line are 4.5° - 104° C (40°-220° F).

	CAUTION
	Never exceed life of facing material. Facing life depends on the volume of material and the total energy over the life of the unit. Expected life (in hrs) can be found by: Time = $\frac{\text{Volume}}{\text{Power} \cdot \text{Wear Rate}}$

	CAUTION
	Before placing the DPC Clutch into service; verify that all screws are secured to the proper torque (See Table 4).

The “DPC” Clutch engages when air pressure is introduced into the Cylinder/Drive Disc. Air pressure pushes the Cylinder/Drive Disc against the Flange Mount Disc, and forces the Cylinder/Drive Disc in the opposite direction. This engages the Friction Facings with the friction surfaces of the Flange Mount Disc and the Friction Disc.

Torque is transmitted through the Cylinder/Drive Disc, and Piston/Drive Disc Splines to the Splined Hub attached to the Shaft with a Q.D. Bushing.

Heat generated at the friction surfaces is dissipated by windage created by the fins on the Flange Mount Disc, and the Friction Disc.

When air is exhausted from the Cylinder, Return Springs pull the Piston to disengaged position.

	WARNING
	Never exceed maximum operating speeds listed for your product (See Table 5).

	WARNING
	Ensure proper guarding of the product is used. Nexen recommends the machine builder design guarding in compliance with OSHA 29 CFR 1910 “Occupational Safety and Health Hazards.”

TABLE 4 Recommended Tightening Torques

Description	DPC-9T	DPC-11T
Shoulder Screw (Item 12)	9 ft-lbs [12 Nm]	9 ft-lbs [12 Nm]
Cap Screw (Item 15)	48 ft-lbs [65 Nm]	48 ft-lbs [65 Nm]
Cap Screw (Item 24)	13 ft-lbs [18 Nm]	13 ft-lbs [18 Nm]
Cap Screw (Item 28)	48 ft-lbs [65 Nm]	48 ft-lbs [65 Nm]
Pull-up Bolts	15 ft-lbs [20 Nm]	30 ft-lbs [41 Nm]

TABLE 5 Maximum Allowable Speed

Model	Outer Assembly	Inner Assembly
DPC-9T	2200 RPM	3000 RPM
DPC-11T	1800 RPM	2500 RPM

PARTS REPLACEMENT



CAUTION

The Nexen DPC Clutch has been balanced at the factory. During disassembly, mark components with chalk alignment marks to insure correct alignment and balance as the DPC Clutch is reassembled (See Figure 6).

When reassembling the Nexen DPC Clutch, make sure all screws are tightened to the recommended torque (See Table 4 in OPERATIONS SECTION).

FRICITION FACING (ITEM 4)

NOTE

Inspect Friction Facings for wear, and replace when they are appropriately 9/32" thick. Friction Facings can be replaced without removing the DPC Clutch from the motor shaft.

REFER TO FIGURE 7.

1. Disconnect the air supply and Hose Assemblies at the Piston/Drive Disc Elbow Fittings.

NOTE

If the "DPC" Clutch is shaft end mounted; remove the Rotary Air Union Cap (Item 25). On through shaft installation; remove the Elbow Fittings (Item 20) from the shaft.

2. Remove Cap Screws (Item 15) and Lockwashers (Item 14).
3. Remove the Friction Disc (Item 6).
4. Remove Shoulder Screws (Item 12) and Springs (Item 13).
5. Slide the Piston/Drive Disc (Item 2) off of the Splined Hub (Item 1).



CAUTION

Working with spring loaded or tension loaded fasteners and devices can cause injury. Wear safety glasses and take the appropriate safety precautions.

6. Remove the Retaining Ring (Item 10).
7. Slide the Cylinder/Drive Disc (Item 3) off of the Splined Hub (Item 1).

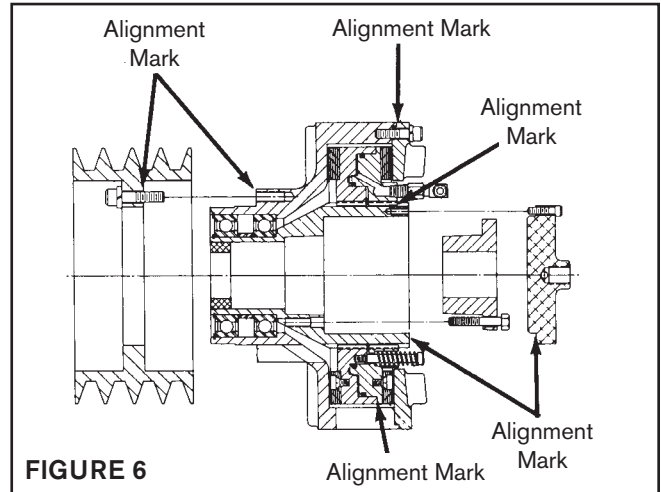

FIGURE 6

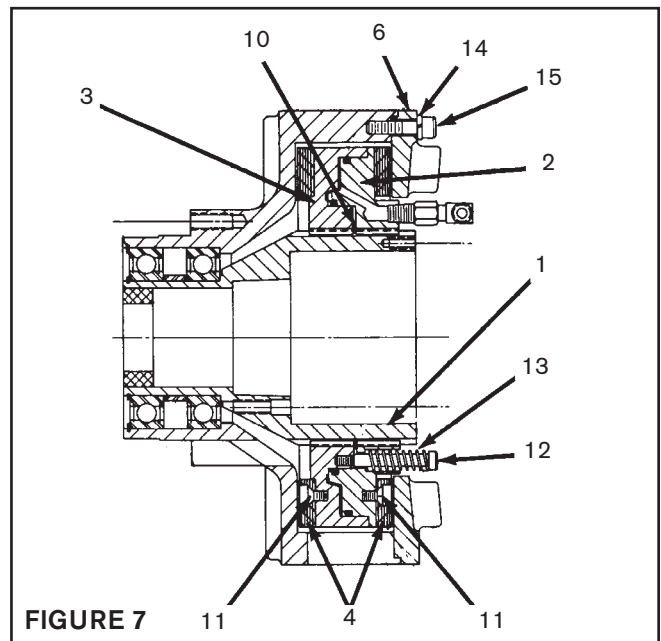

FIGURE 7

8. Remove the Machine Screws (Item 11), and replace worn Friction Facings (Item 4).

NOTE

On some models of the DPC-9T and DPC-11T, the Machine Screws (Item 11) are assembled with a green anaerobic thread locking compound. If remove is difficult, strike the end of the screwdriver with a hammer to break the crystalline structure of this locking compound before attempting to remove the screws. The Machine Screws (Item 11) that are furnished with new Friction Facings have a locking patch, and do not require the use of a thread locking compound.

9. Reverse Steps 1 through 7 to reassemble the DPC Clutch, noting chalk alignment marks and tighten all screws to the recommended torque (See Table 4).

PARTS REPLACEMENT (continued)

O-RINGS (ITEMS 8 & 9)

NOTE

Replace O-rings (Items 8 & 9) if there are noticeable air leaks, or a loss of torque.

REFER TO FIGURE 8.

1. Proceed with Steps 1 through 7 for the Friction Facing Replacement.
2. Remove O-rings (Items 8 & 9), and clean o-ring contact surfaces with fresh safety solvent.
3. Lubricate new O-rings, and o-ring contact surfaces with fresh o-ring lubricant.
4. Install new O-rings (Items 8 & 9).
5. Reverse Step 1 to reassemble the DPC Clutch-noting chalk alignment marks- and tighten all screws to the recommended torque (See Table 4).

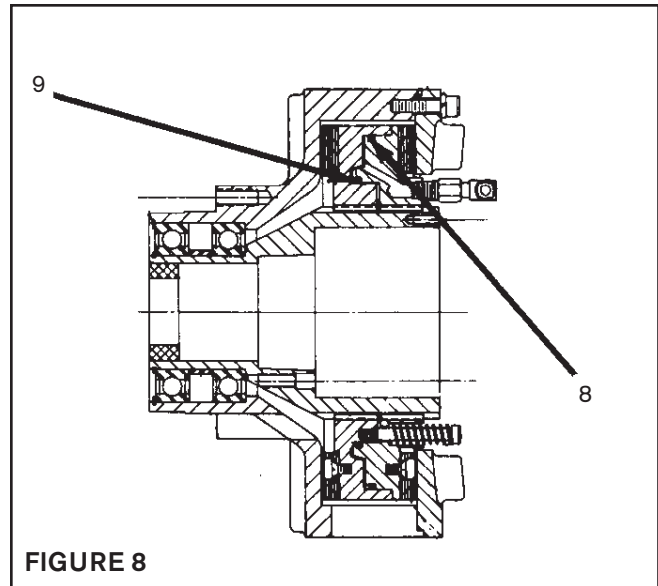

FIGURE 8

BEARINGS (ITEM 16)

NOTE

DPC Clutch Bearings are pre-lubricated, sealed, and do not require further lubrication.

REFER TO FIGURE 9.

1. Disconnect the air supply line, and Hose Assemblies at the Piston/Drive Disc Elbow Fittings.

NOTE

If the DPC Clutch is shaft mounted, remove the Rotary Air Union Cap (Item 25). On through shaft installation, remove the Elbow Fittings (Item 20) from the shaft.

2. Loosen the Q.D. Bushing by first removing the Q.D. Bushing Pull-Up Bolts and Lockwashers. Then insert Pull-Up Bolts into tapped Q.D. Bushing removal holes and alternately and evenly tighten each until the Splined Hub (Item 1) is loose on the Q.D. Bushing.
3. Wedge a screwdriver into the saw-cut in the Q.D. Bushing to loosen the Q.D. Bushing from the Shaft; then remove the "DPC" Clutch.
4. Remove Cap Screws (Item 28), and Lockwashers (Item 27), and Sheave (Item 26) in mounted on the DPC Clutch.
5. Proceed with steps 1 through 7 for the Friction Facing replacement.

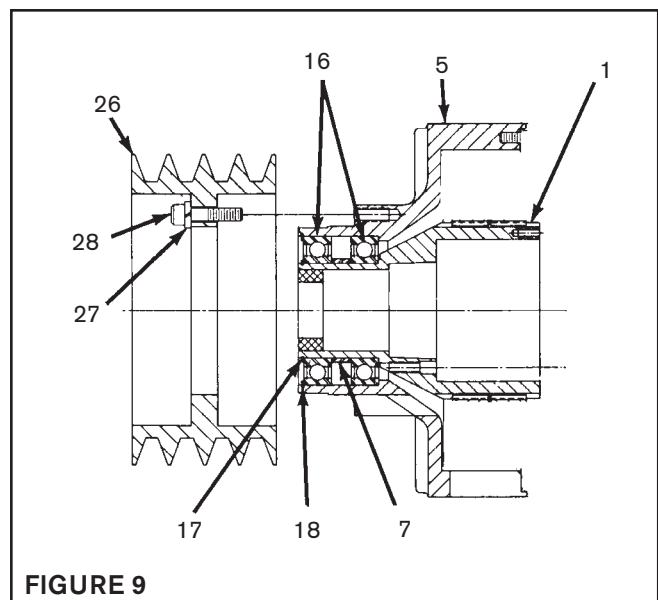
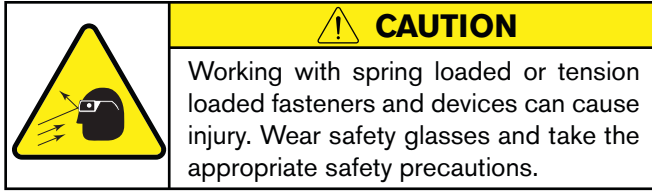

FIGURE 9

BEARING PARTS REPLACEMENT (continued)



REFER TO FIGURE 9.

6. Remove Retaining Ring (Item 17).
7. Fully supporting the Housing (Item 5); press the Hub (Item 1), out of the Housing and Bearings.
8. Remove Retaining Ring (Item 18).
9. Fully supporting the Housing (Item 5); push the Bearing (Item 16), and Spacer (Item 17), out of the Housing.
10. Clean bearing contact surfaces of both Housing (Item 5), and Hub (Item 1) with fresh safety solvent.
11. Press new Bearings (Item 16), and Spacer (Item 7) into the Housing (Item 5).

NOTE

When installing new Bearings; carefully align the Bearing O.D. with the Housing bore. Apply Loctite® RC 601 or equivalent to the outer race of the new Bearings.

12. Install Retaining Ring (Item 18).
13. Fully supporting the inner race of the new Bearings; press the Hub (Item 1) into the Bearings, and Housing.
14. Install Retaining Ring (Item 17).
15. Reverse Steps 1 through 5 to reassemble the DPC Clutch. Be sure to note the chalk alignment marks and tighten all screws to the recommended torque (See Table 4).

REPLACEMENT PARTS LIST

The item or balloon number for all Nexen products is used for part identification on all product parts lists, product price lists, unit assembly drawings, bills of materials, and instruction manuals.

When ordering replacement parts, specify model designation, item number, part description, and quantity. Purchase replacement parts through your local Nexen Distributor.

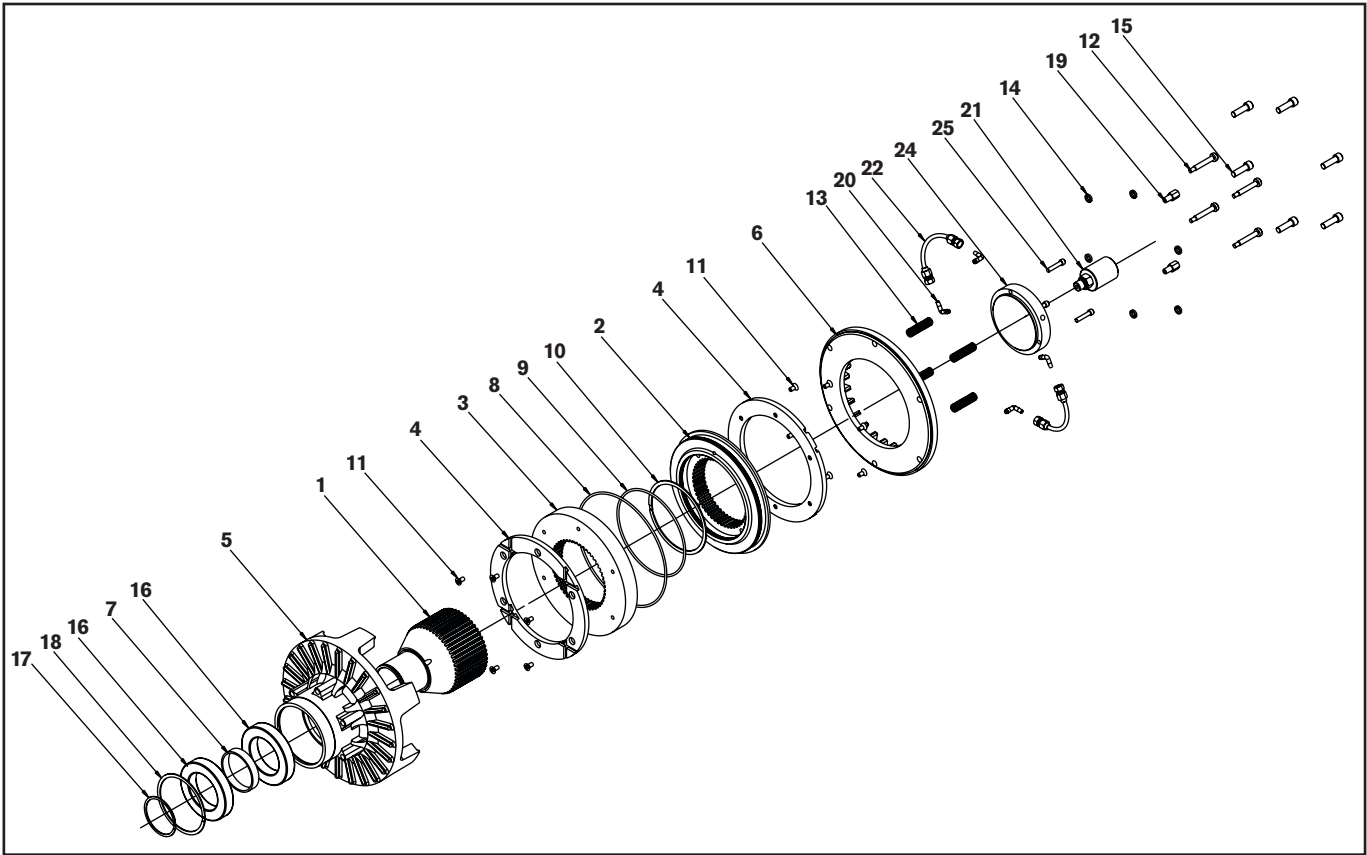

ITEM	DESCRIPTION	QTY
1	Hub	1
2	Piston/Drive Disc	1
3	Cylinder/Drive Disc	1
4	Friction Facing	2
5	Housing	1
6	Friction Disc	1
7	Spacer	1
8	O-ring Seal (large)	1
9	O-ring Seal (small)	1
10	Retaining Ring	1
11	Machine Screw	*
12	Shoulder Screw	**
13	Spring	**
14	Lockwasher	6
15	Cap Screw	6
16	Bearing	2
17	Retaining Ring	1

ITEM	DESCRIPTION	QTY
18	Retaining Ring	1
19	Adapter Fitting	2
20	Elbow Fitting	4
21	Rotary Air Union	1
22	Hose Assembly (not shown)	2
23	Hose Assembly (not shown)	1

Rotary Air Union Cap

24	Rotary Air Union Cap	1
25	Cap Screw	3

Sheave

26	Sheave	1
27	Lock Washer	6
28	Cap Screw	6

MODEL	* QTY	** QTY
DPC-9T	12	1
DPC-11T	16	4

WARRANTY

Warranties

Nexen warrants that the Products will (a) be free from any defects in material or workmanship for a period of 12 months from the date of shipment, and (b) will meet and perform in accordance with the specifications in any engineering drawing specifically for the Product that is in Nexen's current product catalogue, or that is accessible at the Nexen website, or that is attached to this Quotation and that specifically refers to this Quotation by its number, subject in all cases to any limitations and exclusions set out in the drawing. NEXEN MAKES NO OTHER WARRANTY, EXPRESS OR IMPLIED, AND ALL IMPLIED WARRANTIES, INCLUDING WITHOUT LIMITATION, IMPLIED WARRANTIES OF MERCHANTABILITY AND FITNESS FOR A PARTICULAR PURPOSE ARE HEREBY DISCLAIMED. This warranty applies only if: (a) the Product has been installed, used and maintained in accordance with any applicable Nexen installation or maintenance manual for the Product; (b) the alleged defect is not attributable to normal wear and tear; (c) the Product has not been altered, misused or used for purposes other than those for which it was intended; and (d) Buyer has given written notice of the alleged defect to Nexen, and delivered the allegedly defective Product to Nexen, within one year of the date of shipment.

Exclusive Remedy

The exclusive remedy for the Buyer for any breach of any warranties provided in connection with this agreement will be, at the election of Nexen: (a) repair or replacement with new, serviceably used, or reconditioned parts or products; or (b) issuance of credit in the amount of the purchase price paid to Nexen by the Buyer for the Products.

Agent's Authority

Buyer agrees that no agent, employee or representative of Nexen has authority to bind Nexen to any affirmation, representation, or warranty concerning the Products other than those warranties expressly set forth herein.

Limitation on Nexen's Liability

TO THE EXTENT PERMITTED BY LAW NEXEN SHALL HAVE NO LIABILITY TO BUYER OR ANY OTHER PERSON FOR INCIDENTAL DAMAGES, SPECIAL DAMAGES, CONSEQUENTIAL DAMAGES OR OTHER DAMAGES OF ANY KIND OR NATURE WHATSOEVER, WHETHER ARISING OUT OF BREACH OF WARRANTY OR OTHER BREACH OF CONTRACT, NEGLIGENCE OR OTHER TORT, OR OTHERWISE, EVEN IF NEXEN SHALL HAVE BEEN ADVISED OF THE POSSIBILITY OR LIKELIHOOD OF SUCH POTENTIAL LOSS OR DAMAGE. For all of the purposes hereof, the term "consequential damages" shall include lost profits, penalties, delay damages, liquidated damages or other damages and liabilities which Buyer shall be obligated to pay or which Buyer may incur based upon, related to or arising out of its contracts with its customers or other third parties. In no event shall Nexen be liable for any amount of damages in excess of amounts paid by Buyer for Products or services as to which a breach of contract has been determined to exist. The parties expressly agree that the price for the Products and the services was determined in consideration of the limitation on damages set forth herein and such limitation has been specifically bargained for and constitutes an agreed allocation of risk which shall survive the determination of any court of competent jurisdiction that any remedy herein fails of its essential purpose.

Inspection

Buyer shall inspect all shipments of Products upon arrival and shall notify Nexen in writing, of any shortages or other failures to conform to these terms and conditions which are reasonably discoverable upon arrival without opening any carton or box in which the Products are contained. Such notice shall be sent within 14 days following arrival. All notifications shall be accompanied by packing slips, inspection reports and other documents necessary to support Buyer's claims. In addition to the foregoing obligations, in the event that Buyer receives Products that Buyer did not order, Buyer shall return the erroneously shipped Products to Nexen within thirty (30) days of the date of the invoice for such Products; Nexen will pay reasonable freight charges for the timely return of the erroneously shipped Products, and issue a credit to Buyer for the returned Products at the price Buyer paid for them, including any shipping expenses that Nexen charged Buyer. All shortages, overages and nonconformities not reported to Nexen as required by this section will be deemed waived.

Limitation on Actions

No action, regardless of form, arising out of any transaction to which these terms and conditions are applicable may be brought by the Buyer more than one year after the cause of action has accrued.

nexen[®]

Nexen Group, Inc.
560 Oak Grove Parkway
Vadnais Heights, MN 55127

800.843.7445
Fax: 651.286.1099
www.nexengroup.com

ISO 9001 Certified