

TeleTalker®

Installation Guide & User Manual Model TEL 040

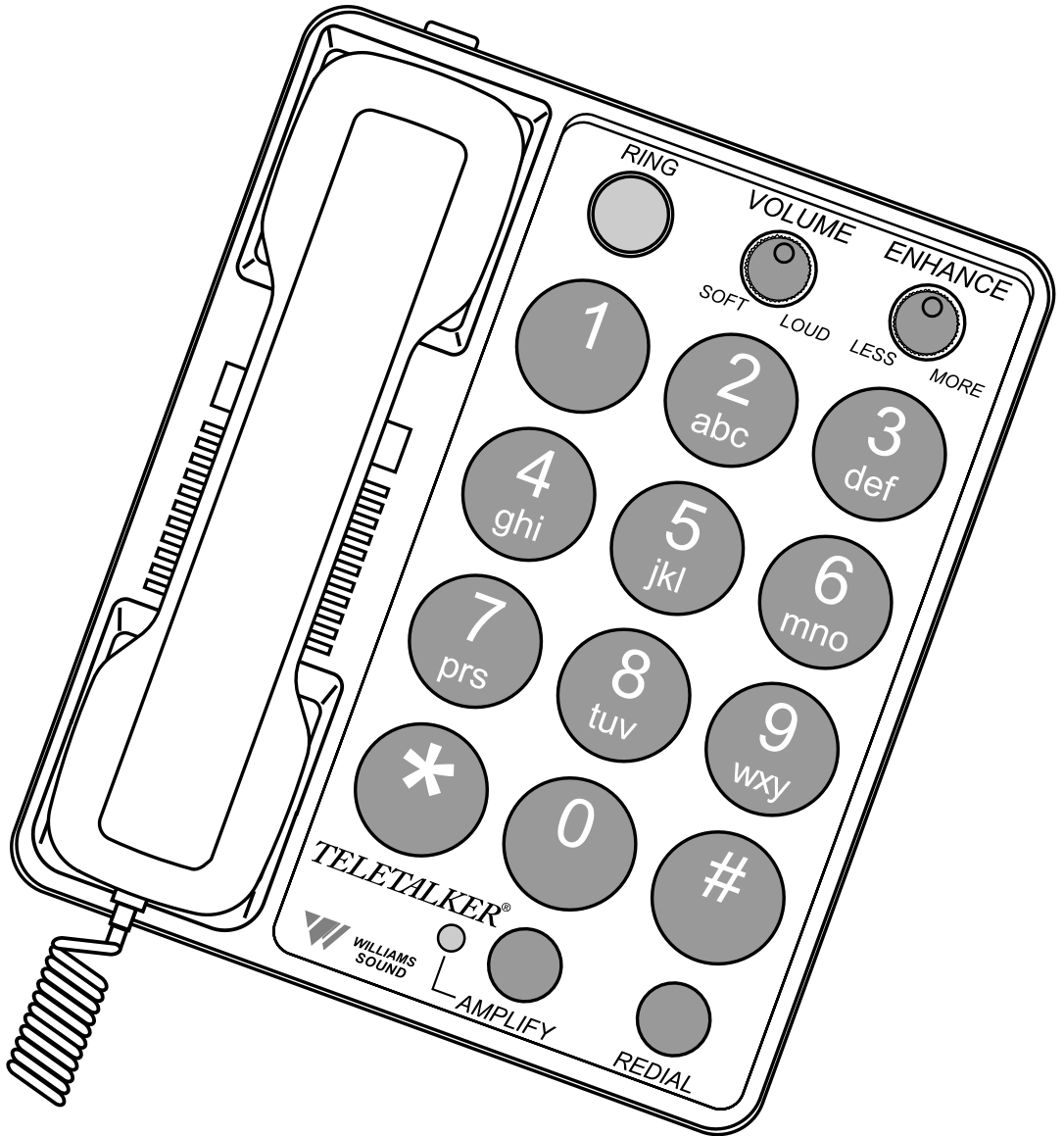

Large Print Version

Important Safety Information

Statements in this manual preceded by the following words are of special significance.

WARNING! Means there is the possibility of personal injury to yourself or others.

CAUTION! Means there is the possibility of damage to the equipment.

Other information of particular importance has been placed in italic type like this.

WARNING!

The TeleTalker is capable of amplifying sounds to a very loud volume. To prevent misuse of the phone by someone who is unfamiliar with its operation and capabilities, **DO NOT** remove the warning labels. Instruct all potential users in its proper operation. Do not let children play with the TeleTalker. When the **AMPLIFY** function is not activated, the TeleTalker functions as a normal telephone.

WARNING!

This telephone can produce very high (loud) sound levels. Always adjust controls to minimum settings before using the phone and alert other users that hearing damage can potentially result from misuse.

WARNING!

This product can be hazardous if immersed in water. To avoid the possibility of electrical shock, do not use it while

in the bathtub or shower, or when you are wet. If you accidentally drop it into water, do not retrieve it until you have first unplugged the line cord from the modular wall jack and the power pack from the AC wall outlet. Do not plug the telephone back in until it has dried thoroughly.

Avoid using the telephone during electrical storms in your immediate area. Urgent calls should be brief. Even though your telephone company may be using protective measures to limit electrical surges from entering your home, absolute protection from lightning is impossible.

If you suspect a gas leak, report it immediately. But use a telephone away from the affected area. The telephone's electrical contacts could create a tiny spark. While unlikely, it is possible this spark could ignite heavy concentrations of gas.

Table Of Contents

<i>Contents</i>	<i>Page</i>
<i>Safety Information</i>	2
<i>Introduction</i>	5
<i>Components</i>	6
<i>Features & Functions</i>	7
<i>Installation Steps</i>	8
<i>Table/Desk Installation</i>	10
<i>Wall Plate Installation</i>	11
<i>Bare Wall Installation</i>	13
<i>TeleTalker Operation</i>	15
<i>Using The Amplify Function</i>	15
<i>Making A Call</i>	16
<i>Answering A Call</i>	16
<i>Using The TeleTalker With A Hearing Aid</i>	17
<i>In Case Of Difficulty</i>	18
<i>Warranty</i>	20
<i>FCC Notices</i>	22
<i>Specifications</i>	23

Introduction

Congratulations on the purchase of your TeleTalker® Enhanced Amplified Telephone System, Model TEL 040. This state-of-the-art Williams Sound product is designed and built with premium quality parts for your assurance of reliability.

The TeleTalker® is designed to improve the audibility and understandability of incoming voice signals by reducing unwanted line noise. It's also designed to improve the clarity of the sound signal by emphasizing higher frequency speech sounds. The TeleTalker functions as either an amplified telephone or as a normal telephone for users who don't need amplification.

We suggest you read this user manual carefully to become familiar with the TeleTalker's features and their function. The manual explains how to install, use, and care for your new TeleTalker.

Components

The following items are included with the TeleTalker:

- Handset
- Base
- Coiled handset cord
- Wall cords (2)
- Power pack
- User Manual

Features & Functions

Amplify Button	Activates Amplify and Enhance functions.
Amplify Indicator	Lights when Amplify function is on.
Enhance Control	Increases high frequency sounds (high frequency boost).
Volume Control	Increases sound volume.
Ring Indicator	Flashes when TeleTalker rings.
Redial Button	Redials last number dialed.
Pulse/Tone Switch	Selects Pulse (rotary phone systems) or Touch-Tone Dialing.
Ringer Volume	Adjusts Ringer volume level.
Ringer Tone Control	Adjusts Ringer tone.

Fig. 1: TeleTalker Features & Functions

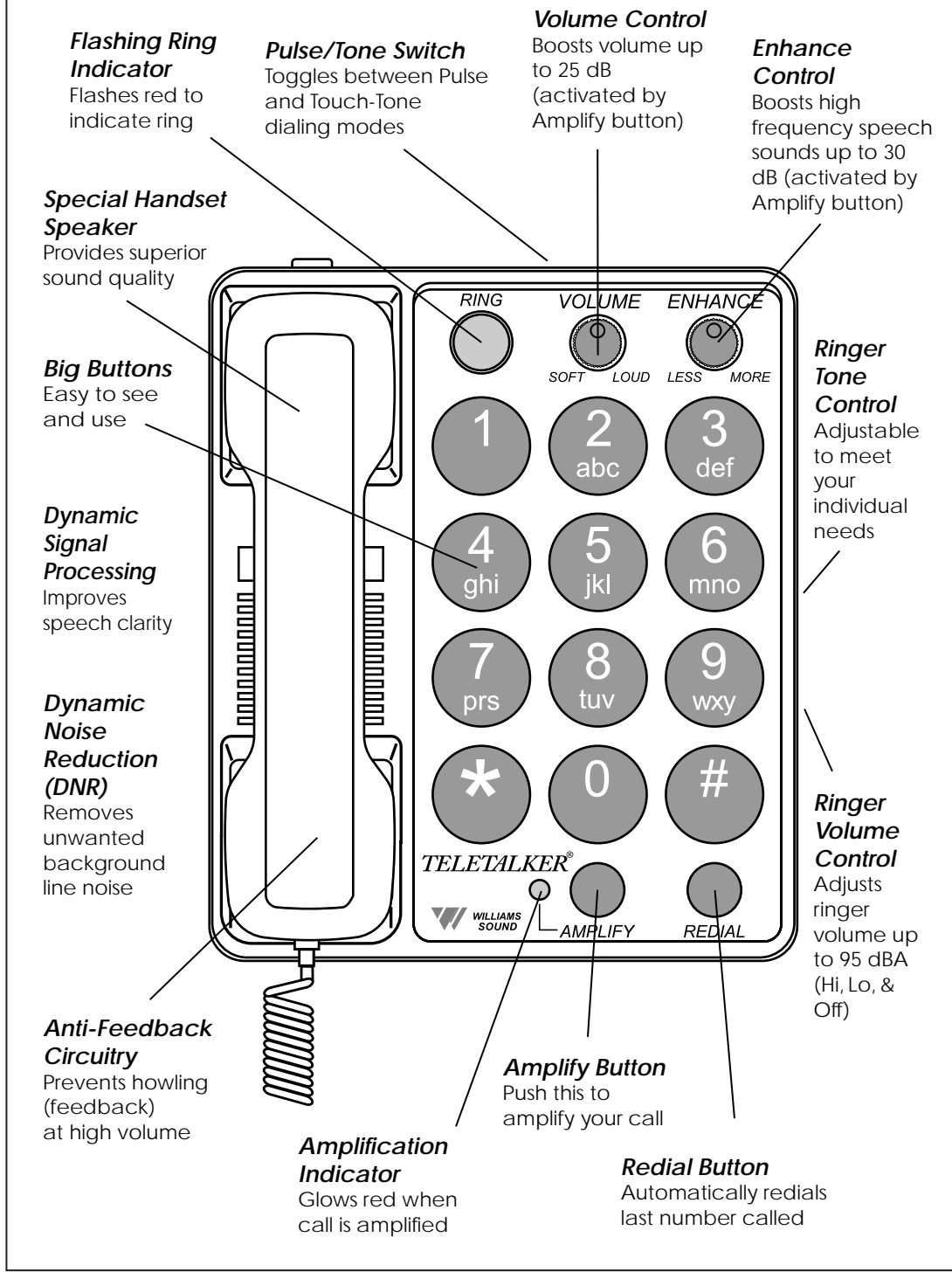

Installation Steps

- Step 1:** Make sure you have a 115 VAC wall outlet and telephone jack within 6 feet of the place you've chosen to install the telephone. If you have an older 4-prong jack, you'll need a modular jack adapter. These adapters are available from electronic, phone, and other retail stores.
- Step 2:** Place the Pulse/Tone Switch, located on the side of the phone, in either Tone or Pulse (Rotary Dial Pulse). *Make sure you choose the correct dialing mode. Tone dialing will not work if you have only dial pulse (rotary) service.*

fig. 2: Pulse/Tone Switch

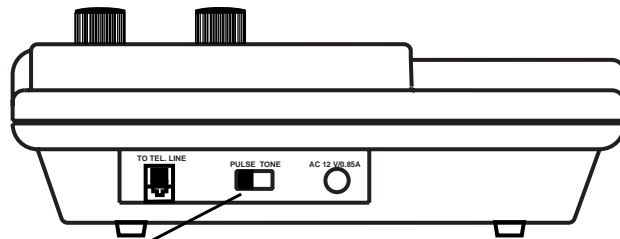

Pulse / Tone Switch

Switches between touch-tone and rotary dial modes.

Step 3: Set Ringer Volume and Tone Controls to desired level. (see fig.3)

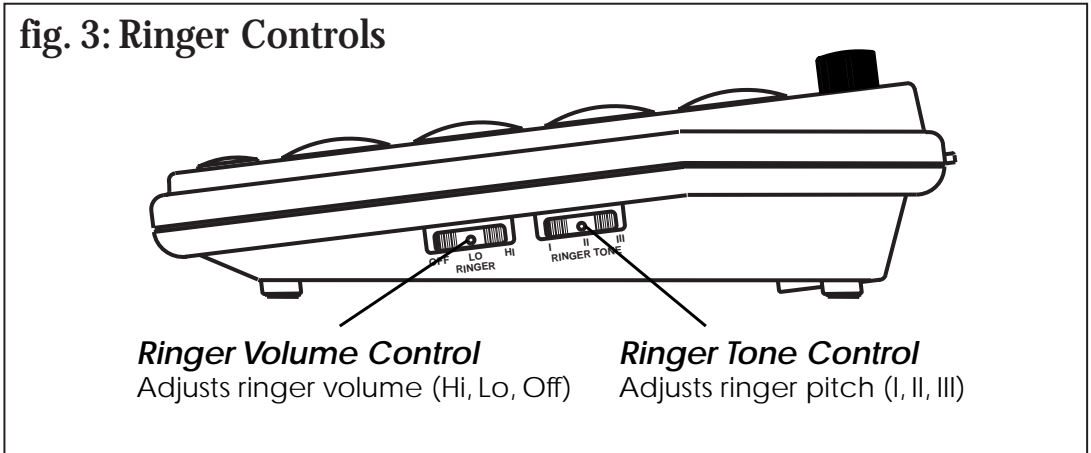

Step 4: Plug the coiled handset cord into the handset. Plug the other end into the telephone base. (see fig. 4)

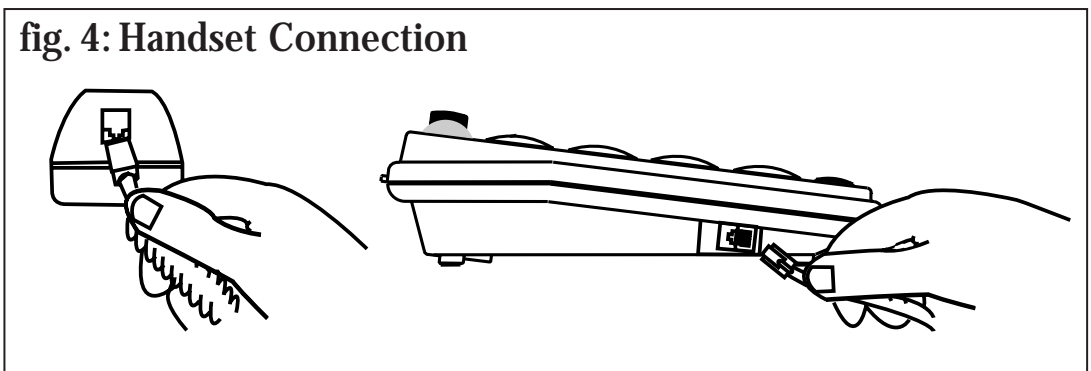

Step 5: Plug the Power Pack cord into the Power Jack located at the top end of the telephone. Plug the Power Pack into an unswitched AC outlet within 6 feet of the telephone. (see fig. 5)

fig. 5: Power Connection

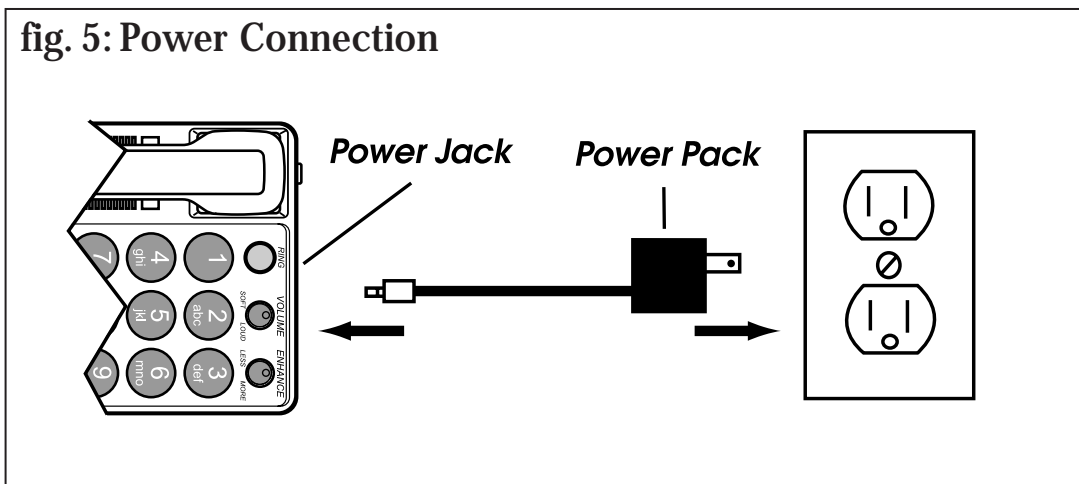

Step 6: Perform either Table/Desk installation or Wall installation as outlined on the following pages.

For Table/Desk Installations

Step 1: Plug the long line cord into the jack on the back of the telephone base. *(see fig. 6)*

Step 2: Plug the other end of the line cord into a modular baseboard jack. Make sure both ends snap into place firmly. *(see fig. 6)*

fig. 6: Line Cord Connection

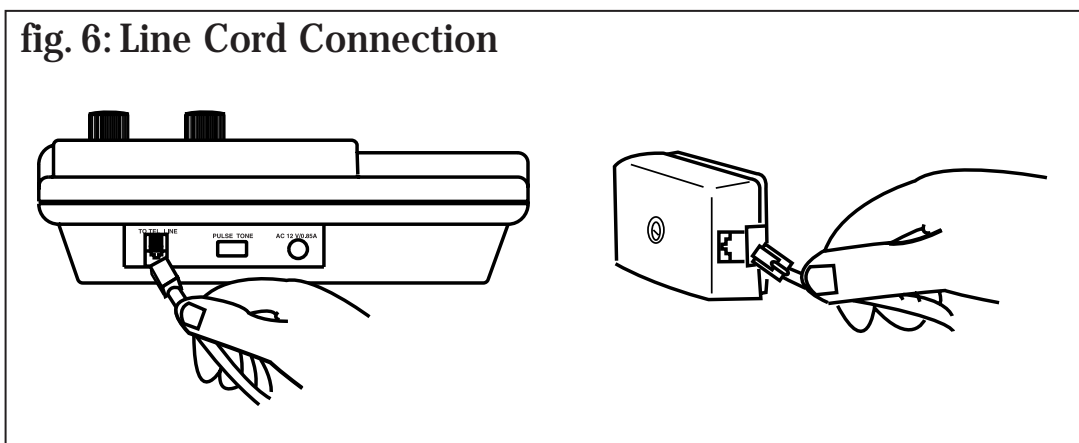

Step 3: Lift the handset and check for dial tone. If you don't hear a dial tone, see *In Case Of Difficulty*, page 18.

Note: To disconnect, squeeze the clip on the plug and pull it out from the jack. Remove the Power Pack plug from telephone.

For Wall Plate Installations

If you prefer, the TeleTalker can also be mounted on a studded wall phone plate. If you don't have a phone plate installed, talk to your phone company or local phone products store.

Step 1: Clip the plastic wall mounting bracket (included) into bottom of the TeleTalker base unit. (*see fig. 7 on following page*) Make sure the tabs snap in securely. This will make the base unit level with the wall.

Step 2: Reverse the handset hanger found in the handset cradle to prevent the handset from falling.

Step 3: Plug the short line cord into the jack on the top of the telephone and thread the line through the channel to the cavity on the back of the base unit.

Step 4: Hold the telephone next to the wall-phone jack and plug the line cord into the jack, leaving any slack in the base unit cavity. Then push the phone against the mounting studs so the studs are hooked into the upper and lower keyhole slots of the phone. Slide the phone down until it snaps into place. (see fig. 7)

Step 5: Check for a dial tone. If you can't hear a dial tone, see *In Case Of Difficulty*, page 18.

Note: To remove a wall-mounted telephone, slide the phone up and pull it slightly away from the wall. Disconnect the line cord by squeezing the clip on the modular plug and pulling it from the jack.

fig. 7: Wall Installation

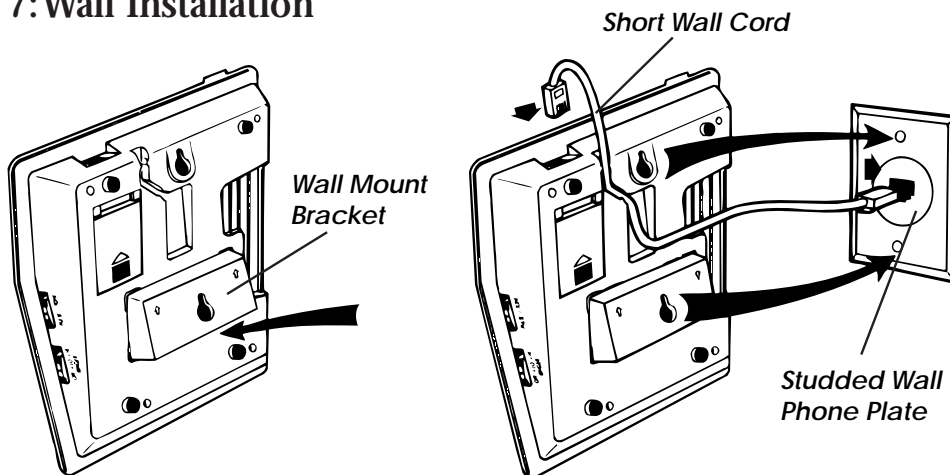

Bare Wall Installation

Even if you don't have a studded wall phone plate, you can still mount the TeleTalker on any wall surface within six feet of a standard modular jack and AC outlet. To mount the phone farther from the jack you'll need a longer line cord or a telephone extension cord. In either case, place the AC power pack in a location which will not be subject to disturbance.

Step 1: Measure and mark the wall for mounting screws.

Mark two points 3-1/4 inches apart for upper and lower mounting screws. The lower mark should be 48–52 inches from the floor. Use a level to make sure the marks are aligned vertically.

Step 2: Install the mounting screws (not included). Use wood screws for stud mounting, anchor screws for hollow wall mounting. Drive the screws almost completely in, leaving a 1/8 inch space between the wall surface and the bottom of the screw head (about the thickness of two stacked pennies).

- Step 3:** Reverse the handset hanger to prevent the handset from falling.
- Step 4:** Mount the TeleTalker.
Hang the telephone on the mounting screws and push down gently until it snaps into place
- Step 5:** Connect the line cord to the jack on the top of the phone. Plug the other end of the line cord into a modular wall jack.
Make sure it snaps firmly into place.
- Step 6:** Connect the AC power pack to a wall AC outlet.
- Step 7:** Check for the dial tone.
If you can't hear a dial tone, see *In Case Of Difficulty*, page 18.
- Note:** To disconnect the telephone, squeeze the clip on the modular plug and pull it out of the jack.

TeleTalker® Operation

Using The Amplify Function

Before activating the Amplify function, turn the volume and enhancement controls to their minimums (counter-clockwise). To activate amplification, press the red Amplify button. The red indicator light will glow when activated. The Amplify function automatically turns off when you hang up the phone.

WARNING!

The TeleTalker is capable of amplifying sounds to a very loud volume. Always set the VOLUME CONTROL to the MINIMUM setting before using the phone. To prevent misuse of the phone by someone who is unfamiliar with its operation and capabilities, DO NOT remove the warning labels. Instruct all potential users in its proper operation. Do not let children play with the TeleTalker. When the Amplify function is not activated, the TeleTalker functions as a normal telephone.

Using The Volume Control

Turn the volume control knob clockwise to increase volume, counter-clockwise to decrease volume.

Using The Enhancement Control

Turn the Enhance control knob clockwise to boost high frequencies, counter-clockwise to decrease the boost of high frequencies.

Making A Call

- Step 1:** Lift the handset and check the Volume Control setting.
- Step 2:** Press the Amplify button. The Red LED should light.
- Step 3:** Adjust the Volume and Enhance Controls to comfortable levels.
- Step 4:** When you hear a dial tone, dial the number and use as a regular phone. Adjust the volume and enhancement controls for best understanding of the remote party.
- Step 5:** When you hang-up the phone, the Amplify function automatically turns off.

Answering A Call

- Step 1:** Check the Volume Control setting, lift the handset.
- Step 2:** Press the Amplify button. The red Amplify indicator should light.

Step 3: Adjust the Volume and Enhance controls to comfortable settings.

Step 4: When you hang-up the phone, the Amplify function automatically turns off.

Using the TeleTalker With A Hearing Aid

The handset can be used directly with hearing aids equipped with a telecoil (T-coil). Move your hearing aid T-switch to the “T” position and hold the handset close to your hearing aid. The volume can be adjusted with the TeleTalker volume control.

In Case Of Difficulty

Cannot hear the other person speak. This only occurs when the TeleTalker is in Amplify mode.
When you use the Amplify feature, the TeleTalker operates in half-duplex mode. This means that while you speak, the handset receiver shuts off. If it did not, the extremely loud volumes produced by the TeleTalker would cause feedback.

When using the TeleTalker in Amplify mode, do not speak when the other party is speaking.

Can answer calls but cannot make them
The pulse/tone switch is set in the wrong position.
Change it to pulse mode.

No dial tone when you pick-up handset
There are a number of potential causes to this problem:

1. Cords on handset or phone are not plugged into jacks. Make sure connectors are plugged in securely.
2. The cord could be damaged. If so, replace the cord.

3. The wall jack could be improperly wired. Check the wall jack for proper wiring.
4. Your phone line could be out of order. Contact your local phone company.

Can make calls, but phone doesn't ring for incoming calls.

There are a number of potential causes to this problem:

1. The handset may not be placed properly on the base. Make sure it is resting properly on the base.
2. The Ringer Volume Control may be set to OFF. Adjust the switch to LO or HI.
3. Too many phones or phone devices may be connected to the same line. If so, remove other phones or devices from line.
4. The Pulse/Tone Switch may be in the wrong position. Your phone line may be set to accept only pulse dialing. If so, be sure to set this switch correctly.
5. Your older extension phone may cause the TeleTalker to cut off. If so, use Williams Sound's optional Equalizer Phone Accessory (TEL 007). The Equalizer balances the amount of phone line current drawn by older phones using the same line as the TeleTalker.

Warranty

Williams Sound Products are engineered and manufactured to give many years of trouble free service. Occasionally, latent defects will occur. If this happens, return the product to us with shipping cost prepaid and advise us by letter of the observed difficulty.

During the first five years following the date of purchase, we will promptly repair or replace the product and return it at our expense. After five years from the date of purchase, we will service our products for a modest service charge. Please return the enclosed warranty card to register your date of purchase.

This warranty does not extend to intentional or accidental physical damage, or damage caused by leaking batteries. Cords and power supply are warranted for 90 days. This warranty applies only to products returned to Williams Sound for service.

To return a product for service, call the phone number below and request a Return Authorization (RA) number. Unauthorized modifications or repairs of the product will void the warranty.

Williams Sound Corp.
10399 West 70th Street
Eden Prairie, MN 55344-3459

Phone: 1-800-843-3544 / 1-612-943-2252

Fax: 1-612-943-2174

**Web: www.williamssound.com
info@williamssound.com**

FCC Registration Notice

Your new TeleTalker product has been registered with the Federal Communications Commission (FCC). This product complies with standards in Part 68 of the FCC Rules. The FCC requires us to provide you with the following information:

1. Connection and use with the nationwide telephone network
The FCC requires that you connect your product to the nationwide telephone network through a modular telephone outlet or jack. The modular telephone outlet or jack to which the telephone must be connected is a USOC RJ-11C or RJ-11W.
This equipment may not be used with Party Line Service or with Coin Telephone Lines.
2. Notification to the telephone company
The FCC requires that upon request of your local telephone company, you provide the following information:
 - A. The 'line' to which you will connect the telephone equipment (your phone number).
 - B. The telephone equipment's FCC registration number and Ringer Equivalence Number (REN). These numbers are on the back or bottom of your telephone equipment.
The REN is useful to determine how many devices you may connect to your telephone line and still have them ring when your telephone line is called. In most, but not all areas, the sum of all REN's should be 5 or less. You may want to contact your local telephone company if you experience problems.
3. Repair instructions
If it is determined that your telephone equipment is malfunctioning, the FCC requires that it not be used and that it be unplugged from the modular outlet until the problem has been corrected. Repairs to this telephone equipment can only be made by the manufacturer or its authorized agents or by others who may be authorized by the FCC. For repair procedures, follow the instructions under the section entitled Warranty.
4. Rights of the telephone company
If your product is causing harm to the telephone network, the telephone company may temporarily discontinue your telephone service. If possible, they will notify you before they interrupt service. If advance notice isn't practical, you'll be notified as soon as possible. You'll be given the opportunity to correct the problem, and you'll be informed of your right to file a complaint with the FCC.
Your telephone company may make changes in its facilities, equipment, operations, or procedures that could effect the proper functioning of your TeleTalker product. If such changes are planned, you'll be notified.
5. This telephone is compatible with inductively coupled (Telecoil) hearing aids.

Interference Information: Part 15 Of FCC Rules

Some telephone equipment generates and uses radio-frequency energy and, if not installed properly, may cause interference to radio and television reception.

Your TeleTalker product has been tested and found to meet the standards for a Class B computing device, as specified in Subpart J of Part 15 of the FCC Rules. These specifications are designed to provide reasonable protection against such interference in a residential installation. However, there is no guarantee that interference will not occur in a particular installation.

If your TeleTalker product causes interference to radio or television reception when it's in use, you might correct the interference with any one of these measures.

1. Where it can be done safely, re-orient the receiving telephone or radio antenna.
2. To the extent possible, relocate the television, radio or other receiver with respect to the telephone equipment.
3. If your telephone product runs on AC power, plug your product into an AC outlet that's not in the same circuit as one used by your radio or television.

SPECIFICATIONS

TeleTalker Amplified Telephone, Model TEL 040

Dimensions:	2.2" D, 8.9" H, 7.6" W (56mm D, 226mm H, 192mm W)
Color:	White with dark gray controls
Wide-band Gain:	25 dB maximum
High Frequency Gain:	30 dB maximum
Audio Freq. Response:	300 Hz to 2800 Hz, \pm 3 dB
Max. HF Acoustic Gain:	55 dB
Sat. Acoustic Output:	130 dB SSPL
Total Harm. Distortion:	< 3% at 120 dB SPL output, 1000 Hz, Enhance control at min
Signal to Noise Ratio:	51 dB, NAB Weighted
Signal Processing:	Dynamic Signal Processing
Noise Reduction:	Dynamic Noise Reduction (DNR®)*
Ringer Volume Control:	Hi, Lo, Off
Ringer Loudness:	90-95 dBA SPL at 1 meter (Hi position)

Ringer Pitch Control:	Adjustable, 3 positions (lo, med, hi)
Flasher:	Jumbo LED, high visibility, red
Connections:	2-wire central office connection, modular plug
Ringer Equivalency Number (REN):	1.0B
Power:	Includes 12 VAC power supply
Warranty:	Five Years, Parts and Labor**

* Trademark of National Semiconductor Corp.

** 90 days on cords and power supply



Williams Sound Corp.

10399 West 70th St., Eden Prairie, MN 55344-3459

U.S.A. 800-328-6190 / 612-943-2252 / FAX: 612-943-2174

www.williamssound.com / info@williamssound.com