



HD-IRD-V3

User's Manual

Broadcast integrated receiver decoder for satellite and terrestrial program injection for broadcast headends. Supports advanced transport stream operations for RF, IP, and ASI.

Thor Broadcast Group - Los Angeles, California.

DIRECTORY

Chapter 1 Product Overview	1
1.1 Outline	1
1.2 Features.....	1
1.3 Specifications.....	2
1.4 Principle Chart	3
1.5 Appearance and description.....	3
Chapter 2 Installation Guide	5
2.1 Optional Cabling	5
2.2 Installation Preparation	5
2.3 Wire's Connection	7
2.4 Signal Cable Connection.....	8
Chapter 3 Operation	13
3.1 Main Interface.....	13
3.2 General Setting	14
Chapter 4 NMS Setting	21
Chapter 5 Troubleshooting	21

Chapter 1 Product Overview

1.1 Outline

HD-IRD-V3 HD IRD is Thor's newly designed IRD with added Program control features, integrated FPGA, and a video monitoring LCD on the front panel. The LCD can display programs from ASI, DVB-S2, or IP sources. Dual slots for industry standard CAM modules can be used to multiplex and de-encrypt complete carrier TS streams. Additional programs can be inserted to the MPTS for ASI and IP outputs, while simultaneously decoding a program to scaled or native outputs on HD-SDI, HDMI, YPbPr, and CVBS. Additionally, digital audio output with Dolby passthrough is provided on optical and XLR connectors, analog balanced and unbalanced is also provided. HD-IRD-V3 supports one channel (Tuner, ASI or IP) de-scrambling and provides transparent signal output. User can operate the device by using front panel LCD or NMS browser login. Additional features include the ability to pass the encrypted TS from the input to a second ASI output in addition to decrypted TS output.

1.2 Features

- Generation 3 Processor Core
- Front Panel LCD for confidence monitoring
- Adaptive sensor based environment control
- Dual CAM Conditional Access card bays
- Decodes both MPEG-2 and H.264 programs
- Re-multiplexer and descrambler embedded
- Supports DVB-ASI daisy chain and Cascading
- Support 4 ASI, 1 CVBS, 1 YPbPr, 1 HD/SD-SDI, 1 XLR and RCA, 1 S/P DIF audio, 1 HDMI, and IP output
- Compatible for both HD and SD
- Supports Outputs at 1080I, 720P, SD PAL/NTSC.
- PAL/NTSC identified automatically

- Two CI Slot PCMCIA interfaces.
- Two independent CAM modules: Max decryption of 8 SD programs
- Supports BISS “mode 1” and “mode E”
- Three RJ-45 interfaces: Management, and dual TS outputs
- Maintains programming after power failure
- Supports Closed Captioning streams for both 608 and 708 standards
- Supports manipulation of TS metadata from DVB-S2 streams
- Supports 1 ASI input, tuner input (supporting DVB-S/S2), IP input(UDP)
- SupportDVB-S/S2 demodulation.

1.3 Specifications

Input Interface	Tuner	1 tuner(DVB-S/S2)
	ASI	1 ASI IN
	IP	1 IP
Output Port	ASI Output	2 groups separate output ports (each group has 2 channels)
	Video Output	1xCVBS, 1xYPbPr, 1xHD/SD-SDI, 1 x HDMI
	Audio Output	XLR, L/R
	SPDIF Output	1 SPDIF
Input Level	-65 ~ -25dBm	
Input Frequency	950~2150MHz	
Symbol Rate	2-45M symbols	
Constellation	QPSK, 8PSK	
FEC Code Rate	1/2, 3/5, 2/3, 3/4,4/5, 5/6, 8/9,9/10	
NMS Port	Ethernet Port	10/100M
	Protocols	TS Over IP : UDP, NMS : UDP
Miscellaneous	Dimensions (LxWxH)	482mm*360mm*44mm
	Approx weight	3.2kg
	Power	<20W(Max)
	Temperature	0~45°C(Operating), -20~80°C(Storage)

1.4 Principle Chart

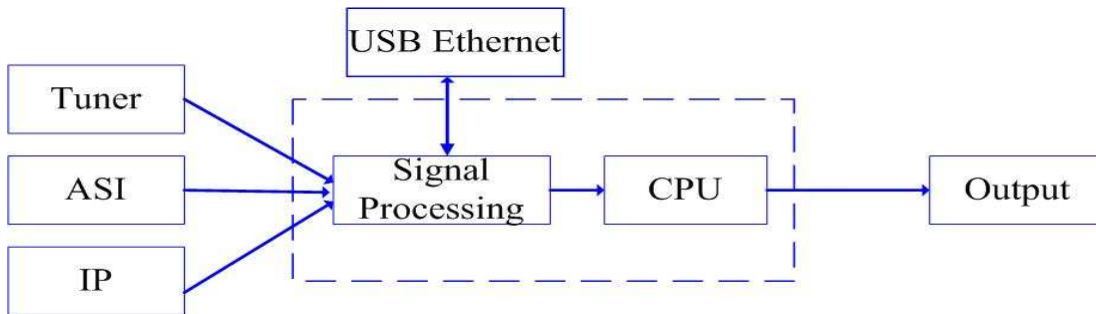

1.5 Appearance and description

Front Panel Illustration:



Indicator area: Status LED's are provided for primary functions

1	LCD Display
2	Alarm Indicator
3	Power Indicator
4	Up/Down/Left/Right Buttons
5	Enter-confirming Key
6	Menu Key
7	Lock Key Indicator
8	LCD Monitor
9	Switch Button
10	PCMCIA interface

Rear Panel Illustration

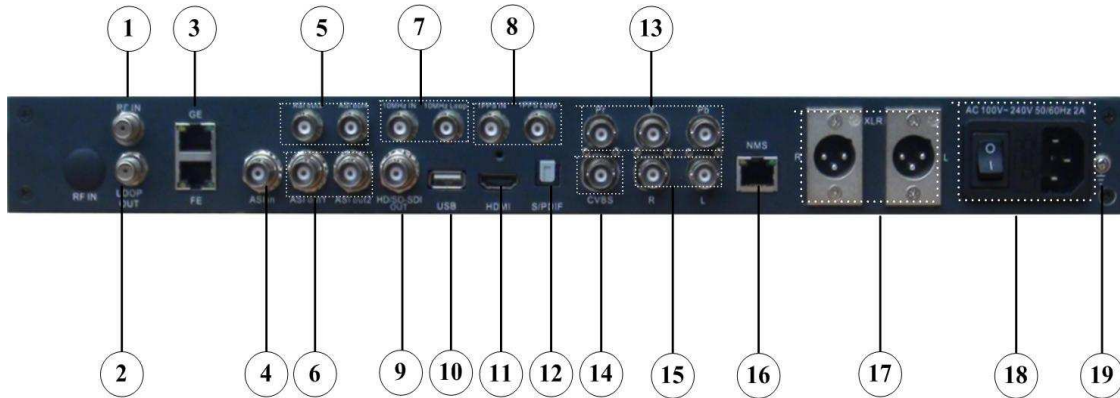

1	RF IN Interface
2	DVB-S/S2 Loop Out Interface
3	IP IN/OUT Interface
4	ASI IN Interface
5	ASI Out3 and ASI Out4 Interface: Output Single TS Stream from tuner.
6	ASI Out1 and ASI Out2 Interface: Output multiplexed or separated TS Stream from tuner, ASI and IP.
7	10MHz IN and 10MHz LOOP interface
8	1PPS IN and 1PPS LOOP interface
9	HDSDI-OUT Interface: HD/SD digital parallel output interface
10	USB interface: Software updating.
11	HDMI Output Interface
12	SPDIF: Digital audio output interface
13	YPbPr: Audio and Video component output interface
14	CVBS: Composite video and audio output interface
15	Audio (L/R channel) output interface
16	NMS Ethernet Port(10-100Mbps)
17	Balance audio output interface
18	Integrated power switch and socket
19	Grounding Wire

Chapter 2 Installation Guide

2.1 Optional Cabling

Thor will provide standard interface cabling for the end users application. Please check the included packing list that came with your order and confirm that all items are present.

Typically bundled cabling and packing lists will include the following items.

- HD-IRD-V3 HD IRD 1pcs
- User's Manual 1pcs
- Power Cord 1pcs
- XLR Interface Cable 2pcs
- RF In and Loop Out Cable 1pcs
- Component Output, CVBS Output and Sound Channel Output Cable 3pcs
- ASI Input and Output Cable 1pcs

Please contact Thor if you are missing any required cabling.

2.2 Installation Preparation

Please refer to the following section for installation procedures. This chapter is intended to be used along with the I/O diagrams from the previous chapter.

The main content of this chapter includes:

- Checking the packing list for missing items
- Preparing relevant environment for installation
- Installing HD IRD
- Connecting signal cables
- Connecting communication port (if it is necessary)

2.2.1 Device's Installation Flow Chart Illustrated as following :

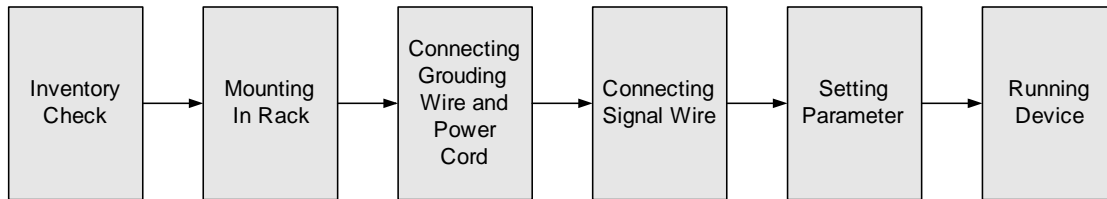

2.2.2 Environment Requirements

Item	Requirement
Machine Hall Space	When user installs machine frame array in one machine hall, the distance between 2 rows of machine frames should be 1.2~1.5m and the distance against wall should be no less than 0.8m.
Machine Hall Floor	Electric Isolation, Dust Free Volume resistivity of ground anti-static material: $1 \times 10^7 \sim 1 \times 10^{10} \Omega$, Grounding current limiting resistance: 1M (Floor bearing should be greater than 450Kg/m ²)
Environment Temperature	5~40°C(sustainable) , 0~45°C(short time) , installing air-conditioning is recommended
Relative Humidity	20%~80% sustainable 10%~90% short time
Pressure	86~105KPa
Door & Window	Installing rubber strip for sealing door-gaps and dual level glasses for window
Wall	It can be covered with wallpaper, or brightness less paint.
Fire Protection	Fire alarm system and extinguisher
Power	Requiring device power, air-conditioning power and lighting power are independent to each other. Device power requires AC power 100-240V 50-60Hz 2A. Please carefully check before running.

2.2.3 Grounding Requirement

- It is important to keep this device grounded to ensure all of the modules function correctly. Correctly grounding the device will also help prevent and electrical interference, lightning, ETC. Also it helps reject minor interference that may disrupt the devices ability to function smoothly. General rule of thumb, make sure the device is grounded when installing anywhere.
- Always use copper wire. When applied correctly the ground must be wrapped well to ensure maximum conduction so it can reduce any high frequencies. The copper ground wire should also be as short and thick as possible..
- Installer must make sure that the two ends of the ground are well conducted and have appropriate anti-rust properties. .
- It is prohibited to use any other device as part of grounding electric circuit
- The area of the conduction between grounding wire and device's frame should be no less than 25mm².

2.2.4 Frame Grounding

All the machine frames should be connected with protective copper strip. The grounding wire should be as short as possible and avoid circling. The area of the conduction between grounding wire and grounding strip should be no less than 25mm².

2.2.5 Device Grounding

Connecting the device's grounding rod to frame's grounding pole with copper wire.

2.3 Wire's Connection

The grounding wire conductive screw is located on the right side of the rear panel, and the power switch, fuse, power supply socket is just beside, whose order goes like this; power switch is on the left ,power supply socket is on the right and the fuse is between them.

- Connecting Power Cord

User can insert one end into power supply socket, while insert the other end to AC power.

- **Connecting Grounding Wire**

When the device solely connects to protective ground, it should adopt this power in an independent way. Especially if you share the same ground with other devices. When the device adopts both currents in a united way, the grounding resistance should be smaller than 1Ω .

⚠ Caution:

Before connecting power cord to HD IRD, user should set the power switch to “OFF”.

2.4 Signal Cable Connection

The signal connections include the connection of input signal cable and the connection of output signal cable. The details are as follows:

2.4.1 HD-IRD-V3 HD IRD Cables Illustration:

- **IP Input Cable Illustration:**



- **HDMI Cable Illustration**



- **XLRInterface Cable Illustration:**



- **RF In and Loop Out Cable Illustration:**



- **Component Output, CVBS Output and Sound Channel Output Cable Illustration:**



- **ASI Input and Output Cable Illustration:**



1PPS& 10MHz Input and Loop-outCable Illustration



2.4.2HD-IRD-V3 HD IRD Satellite Receiver Signal Cable Connection

Illustration:

- **RF IN and LOOP OUT Connection Illustration:**

Users can find the RF IN and LOOP OUT interface on the device according to the connector mark described on the rear panel illustration, connect the cable as shown below. One end is connected to the RF IN interface of satellite receiver while the other end is connected to the satellite signal source equipment or LOOP OUT interface of the previous satellite receiver when several satellite receivers are series connection. As follows:



- **ASI IN and ASI OUT Connection Illustration:**

Users can find the ASI IN and ASI OUT interface on the device according to the connector mark described on the rear panel illustration,connect the cable as shown. One end is connected to ASI IN interface of the HD IRD, the other end is connected to any device that

has ASI output, while when connected ASI OUT interface, the other end of the wire is generally connected to encoder and multiplexer. As follows:



- **Component Output, CVBS Output and Sound Channel Output Connection Illustration:**

Users can find the YPbPr, CVBS and Left/Right sound channel interface on the device according to the connector mark described on the rear panel illustration, and then connect the cable. The other end of the wire is connected to encoders.



- **HDMI Output Connection Illustration:**

Users can find the HDMI interface on the device according to the connector mark described on the rear panel illustration, and then connect the wire. One end of the wire is connected to the HDMI output interface of the HD IRD, while the other end of the wire is connected to encoder or other equipment. As follows:



● IP Output Connection Illustration:

Users can find the IP IN/OUTPUT interface on the device according to the connector mark described on the rear panel illustration, and then connect the wire. One end of the wire is connected to the IP input/output interface of the HD IRD, the other end of the wire is connected to devices with IP OUT/INPUT as follows:



● XLR Output Connection Illustration:

Users can find the XLR interface on the device according to the connector mark described on the rear panel illustration, and then connect the wire. One end of the wire is connected to the XLR output interface of the HD IRD, the other end of the wire is connected to IP encoder. As follows:



10MHz IN & 1PPS IN Connection Illustration:

You can find the 1PPS and 10MHz interfaces on the device according to the connector mark described on the rear panel illustration, and then connect the wires on the condition that the SFN solution is involved. One end of the wires is connected to the 1PPS IN and 10MHz IN interfaces of the HD IRD, and the other end of the wires is connected to GPS as follows:



Chapter 3 Operation

The front panel of HD-IRD-V3HD IRD is the user-operating interface and the equipment can be conveniently operated entirely from the front panel. All available configuration settings can be accessed through the interface menu tree. Please refer to the following guide for assistance:

Keyboard Function Description:

MENU: Cancel current entered value, resume previous setting; Return to previous menu.

ENTER: Activate the parameters which need modifications, or confirm the change after modification.

LEFT/RIGHT: Choose and set the parameters.

UP/DOWN: Modify activated parameter or paging up/down when parameter is inactivated.

LOCK: Locking the screen / canceling the lock state. After pressing lock key, the system will question the users to save present setting or not. If not, the LCD will display the current configuration state.

3.1 Main Interface

Switch on the IRD, the LCD will display the equipment type and current output stream as shown on the following page,

DVB-S2 BTS HD IRD
Out Stream 00.006Mbps

Then pressing the “LOCK” key on the front panel to enter to the main menu as below:

- ▶ 1 Input Setting
- 2 Output Setting
- 3 Decoder Setting
- 4 Descramble Setting
- 5 Network Setting
- 6 Saving Configuration
- 7 Loading Configuration
- 8 Version (SNMP)
- 9 Language

3.2 General Setting

All options are available from these 9 root menu trees.

3.2.1 Input Setting

User can press “Enter” key to enter into the menu of the input setting.

- 1.1 Tuner (DVB-S2)
- 1.2 ASI
- 1.3 IP

3.2.1.1 Tuner In

Here we take 1.1 Tuner (DVB-S2) signal in as an example:

The page menu from 1.1 to 1.3 represents the tuner, ASI and IP input ports of the IRD. User can multiplex the input programs from any port to output any program or all the programs at the same time. By pressing the “Enter” key, the device will take a while to analyze the input TS or signal and then display the program list at the submenu, say, 1.1.1-1.1.6

- 1.1.1 Prog Parse
- 1.1.2 Sat Freq Set
- 1.1.3 LNB Freq Set
- 1.1.4 Symbol Rate
- 1.1.5 LNB Voltage
- 1.1.6 22KHz Switch

By pressing the “Enter” key to enter the submenu of 1.1.1

1.1.1 Prog: 00 Mux: 00

At the submenu 1.1.1, the LCD displays the program number and the count of programs multiplexed.

User can also check and set the satellite frequency, LNB frequency and symbol rate of its corresponding submenu “1.1.2”, “1.1.3”, “1.1.4”.

1.1.2 Sat Freq Set
3840MHZ

1.1.3 LNB Freq Set
5150MHz

1.1.4 Symbol Rate
27500KHz

At the submenu 1.1.5, user can decide which LNB voltage to apply.

1.1.5 LNB Voltage
Vertical (13V) ◀
Horizontal (18V)
OFF

At the submenu 1.1.6, user can choose to turn on the 22 KHz to search the programs from KU band.

1.1.6 22 KHz Switch
▶ OFF ON

3.2.1.2 ASI IN

Return to the upper menu to enter into 1.2 ASI IN, and users can view the program number and the count of programs multiplexed.

1.2.1 Prog Parse

Prog: 00	Mux: 00
----------	---------

3.2.1.3 IP IN

Entering into 1.3 IP, it displays below page:

▶ 1.3.1 Prog Parse

1.3.2 Input IP Addr

1.3.3 Input Port

Similarly, 1.3.1 Prog Parse offers the same information with 1.1.1 and 1.2.1.

User also could check and set the input IP address and input port of its corresponding submenu “1.3.2”, “1.3.3”.

1.3.2 Input IP Address
224.002.002.002

1.2.1 Input port
1001

3.2.2 Output Setting

User can press “Enter” key to enter into below menu of the output setting and set its corresponding parameters or functions under the right submenus.

- ▶ 2.1 Multiplex Set
- 2.2 Output Bit rate
- 2.3 Tran stream ID
- 2.4 Original/Net ID
- 2.5 IP Output

3.2.3 Decoder Setting

User can press “Enter” key to enter into below menu of the decoder setting and execute video setting, audio setting, program selecting and search.

- ▶ 3.1 Video Setting
- 3.2 Audio Setting
- 3.3 Program Select
- 3.4 Search

3.2.3.1 Video Setting

User can enter into below submenu by pressing the “Enter” key.

- ▶ 3.1.1 Resolution
- 3.1.2 Standard
- 3.1.3 Subtitle
- 3.1.4 CC Switch
- 3.1.5 Finger Switch
- 3.1.6 Aspect Ratio

Users can select from the assortment of presets of the following: Resolution, Standard, & Aspect Ratio; and choose whether to turn on or turn off the following: Subtitle, CC Switch, & Finger Switch of their corresponding submenus.

3.2.3.2 Audio Setting

Users can enter into below submenu by pressing the “Enter” key, then select the audio, choose the ES mode (consists of stereo, left channel, right channel) and adjust the volume

under submenu 3.2.1, 3.2.2, and 3.2.3.

Also, users can select the Audio SPDIF from “Auto, PCM, Compressed and OFF” under 3.2.4. andalso choose between “Auto” and “2 Channels” under 3.2.5.

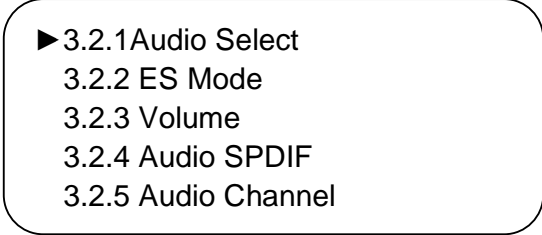

▶ 3.2.1 Audio Select
3.2.2 ES Mode
3.2.3 Volume
3.2.4 Audio SPDIF
3.2.5 Audio Channel

3.2.3.3 Program Select



3.3 Program Select
▶ 1 CCTV-1

Users can select the inputting programs to encode under this menu by pressing up/down button. Here “1” represents the program number and “CCTV-1” represents the program name.

3.3.3.4 Search

Users can search the quantity of programs after entering this menu.



3.4 Search
Total Programs: 8

3.2.4 Descramble Setting

User can press “Enter” key to enter into below menu of the descramble setting. The detailed operation about the descramble function will be explained on the NMS operation part (Chapter 4).

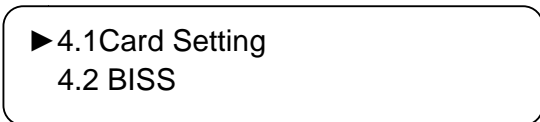

▶ 4.1 Card Setting
4.2 BISS

Enter in 4.1, it shows as follows, and under corresponding submenu, users can select the source of signals, check card information, select programs to be descrambled, and choose CI bitrate.

- ▶ 4.1.1 Input Select
- 4.1.2 A Card Info
- 4.1.3 B Card Info
- 4.1.4 Pro Select
- 4.1.5 CI Bitrate

Under 4.2 BISS menu, users can choose between Mode 1 and Mode E.

- ▶ 4.2.1 Select Mode
- 4.2.2 Mode 1
- 4.2.3 Mode E

3.2.5 Network Setting

User can press “Enter” key to enter into below menu of the network setting.

- ▶ 5.1 IP Address
- 5.2 Subnet Mask
- 5.3 Gateway
- 5.4 MAC Address
- 5.5 Service IP

3.2.6 Saving Config

User can choose to save the current configured parameters by pressing ENTER key. The system displays following page:

Saving, please wait:
Erasing.....

3.2.7 Loading Config

User can restore the device into the last saved configuration by choosing the menu 7.1 “Saved Config”, and also user can restore the device into factory default configuration by

Chapter 4NMS Setting

Network Management System Profile

In addition to the front panel LCD interface, the unit can also be managed and configured through any standard modern web browser. The default IP address is typically 192.168.1.136, however this may be modified during configuration prior to shipping. The unit's management IP address can be easily set or identified from the front panel interface. Please refer to the previous section for assistance.

Chapter 5 Troubleshooting

THOR' several levels of inspection for quality control. All systems shipped by Thor are fully tested and visually inspected after manufacture. Additionally, all units are re-inspected and pre-configured prior to shipping. Under most circumstances, Thor offers free configuration service for most equipment. Thor can set operating parameters prior to shipping, and ensure trouble free operation and installation.

Prevention Measure

- Please ensure that the environment remains within 0 to 45 °C
- Provide adequate ventilation to the heat sinks and side vents.
- Check the input AC voltage, please use appropriate power supplies
- Check that all signal cables are securely installed and nothing is loose.
- Frequently switching on/off device is not recommended. Please allow at least 10 seconds between power cycles.