



DIGITAL HIGH PRECISION WEIGHING SCALES

USER INSTRUCTIONS

© Excell Precision Limited 2006. All rights reserved Worldwide.

The information contained herein is the property of Excell Precision Limited and is supplied without liability for errors or omissions. No part may be reproduced or used except as authorised by contract or other written permission. The copyright and the foregoing restriction on reproduction and use extend to all media in which the information may be embodied.



TABLE OF CONTENTS

BEFORE USING THE SCALE	3
PREPARING TO USE THE SCALE	3
INTRODUCTION	4
1. FEATURES.....	4
2. SPECIFICATIONS.....	5
3. POWER CONSUMPTION.....	5
4. LOW BATTERY WARNING.....	5
LCD DISPLAY SYMBOLS	6
KEYBOARD FUNCTION	7
OPERATION	8
1. DISPLAY BACKLIGHT.....	8
2. ZERO.....	8
3. WEIGHING MODE.....	8
(1). <i>Units Selection</i>	8
(2). <i>Totalising</i>	8
I. Weight Totalising.....	9
II. Recall Totalised Weight Values.....	9
III. Clear Totalised Weight Values.....	9
(3). <i>Deduction of the Container Weight</i>	10
I. The weight of the container is unknown (Tare).....	10
II. Recall the semi-auto tare value.....	10
III. Clear the semi-auto tare.....	10
IV. The weight of the container is known (Pre-set tare).....	11
V. Recall the pre-set tare value.....	11
VI. Clear the pre-set tare value.....	11
(4). <i>Check Weighing</i>	12
I. Pre-set the “Low limit value”, “High limit value”, and “the buzzer” operation.....	12
II. Pre-set the Low limit value only.....	13
III. High/OK/Low indications.....	13
IV. Recall the check weighing setting.....	13
V. Clear the check weighing settings.....	13
4. COUNTING FUNCTION.....	14
(1). <i>Sampling</i>	14
(2). <i>Totalising</i>	14
(3). <i>Check Weighing</i>	14
CONFIGURATION SETTINGS	15
1. CHECK-WEIGHING CONFIGURATION.....	16
2. RS-232 SETTING.....	17
3. EXIT CONFIGURATION SETTINGS.....	18
RS-232 AND RELAY OUTPUT	19
1. RS-232 OR SERIAL PRINTER OUTPUT.....	19
(1) <i>RS-232 (25 Pin ‘D’ type) Pin Description</i>	19
(2) <i>RS-232 Interface Format</i>	19
(3) <i>Data Format</i>	20



2. RELAY OUTPUT	23
(1) <i>Relay Output</i>	23
(2) <i>Relay Pin Description</i>	23
(3) <i>Connection Illustration</i>	23
(4) <i>Power Source Illustration</i>	24
(5) <i>Connection Setting</i>	24



BEFORE USING THE SCALE

To enable you to use this scale correctly, we suggest that you read this manual carefully.

1. Do not use scale in areas with excessive water and don't spray the scale or indicator with water when cleaning. Remove all water from the scale and indicator with a clean dry cloth.
2. The load placed on the platform must not exceed the maximum weighing capacity of the scale.
3. Keep the scale away from high temperatures and damp conditions.
4. If the scale is not going to be used for some time, please clean it and store it in a plastic bag in dry conditions. A desiccant sachet may be included to prevent moisture build up.
5. If the scale is not going to be used for some time, the internal rechargeable battery should be recharged every three months.
6. Before using the scale after a long period of storage, please ensure that the internal battery is fully charged. NOTE: Care should be taken not to leave the internal battery on charge for too long, as this may decrease the life of battery.

PREPARING TO USE THE SCALE

1. Locate the scale on a firm level surface free from vibrations for accurate weight readings.
2. Adjust the four levelling feet to set the scale platform level using the spirit level bubble located on the scale platform frame.
3. Avoid operating the scale in direct sunlight or drafts of any kind.
4. Remove any weight that might be on the scale platform before the scale is switched on.
5. Once the scale has been switched on, it will go through a LCD display test and then re-zero to be ready for use.
6. The scale requires 15~20 minutes warm up before operation to ensure best accuracy.
7. Please note when the  symbol is shown on the display, the internal battery needs to be recharged.
8. All goods weighed should be placed in the centre of the platform for accurate weighing. The footprint of the goods being weighed should not overhang the edges of the platform.



INTRODUCTION

1. FEATURES

1. **Dual-weighing units:** Kilogram (kg) and pound (lb).

2. **Multi-function operation:** Full range tare; Pre-tare; Hold function; Net / Gross weight display; Simple counting; Preset weight value and quantity value; Adjustable noise filter setting from 01 ~ 15 ($\geq 15,000$ division configuration only); Check-weighing configuration.

3. **User-friendly design:**
 - ◆ Auto calibration
 - ◆ AC / DC power supply
 - ◆ Large LCD display with built-in backlight
 - ◆ Auto power-off design to ensure the performance stability
 - ◆ Double over-load protection

4. **Variable calibration settings** depending on the different calibration division:
 - ◆ Standard division (under 10,000 internal resolution): Capacity and weight calibrations are available for accurate weighing.
 - ◆ High precision division (over 10,000 to 150,000 internal resolution): Linearity, capacity, and weight calibrations are available for accurate weighing.

5. **Options**
 - ◆ RS-232 interface
 - ◆ Relay output

6. **High performance in A/D converter (weighing indicators)**
 - ◆ Input sensitivity: 0.3 μ V/D
 - ◆ Sample speed up to 16 times / second
 - ◆ Non-linearity: 0.01 % of full scale
 - ◆ Input zero range: -1 mv ~ +5 mv
 - ◆ Input signal range: -1 mv ~ +14 mv
 - ◆ Load cell excitation: 5V DC \pm 5% 100mA
 - ◆ Load cell drive capacity: up to 4 350 Ω load cells



2. SPECIFICATIONS

The available capacities for selection are different and depend on various models:

Capacity	Division
3 kg (6 lb)	0.2 g (0.0005 lb)
6 kg (12 lb)	0.2 g (0.0005 lb)
7.5 kg (15 lb)	0.5 g (0.001 lb)
15 kg (30 lb)	1 g (0.002 lb)
30 kg (60 lb)	2 g (0.005 lb)
75 kg (60 lb)	5 g (0.01 lb)
150 kg (150 lb)	10 g (0.02 lb)
300 kg (600 lb)	20 g (0.05 lb)
600 kg (1200 lb)	50 g (0.1 lb)
Operating Temperature: 0°C ~ 40°C (32°F ~ 104°F) OIML: -10°C ~ 40°C (14°F ~ 104°F)	
Power Source: AC 110V/220V (±10%) + DC 6V/4.5AH Rechargeable Battery	
Display: LCD, 6 digits, 25 mm (Height), EL backlight	

3. POWER CONSUMPTION

1. The power consumption is around DC 20 mA (system + load cell), the rechargeable battery can be used up to 200 hours.
2. The power consumption is around DC 67 mA (system + load cell + backlight), the rechargeable battery can be used for 60 hours approximately.
3. The power consumption is around DC 71 mA (system + load cell + backlight + RS-232), the rechargeable battery can only be used for 56 hours approximately.

4. LOW BATTERY WARNING

Please note when the  symbol is shown on the display, the internal battery needs to be recharged.

- ✓ The scale will power off automatically without recharging after the low battery symbol shows upon for 20 to 30 hours (3 to 5 hours if the backlight is active) on the display. As a recommendation, the scale must be fully recharged before operating the scale again.



LCD DISPLAY SYMBOLS

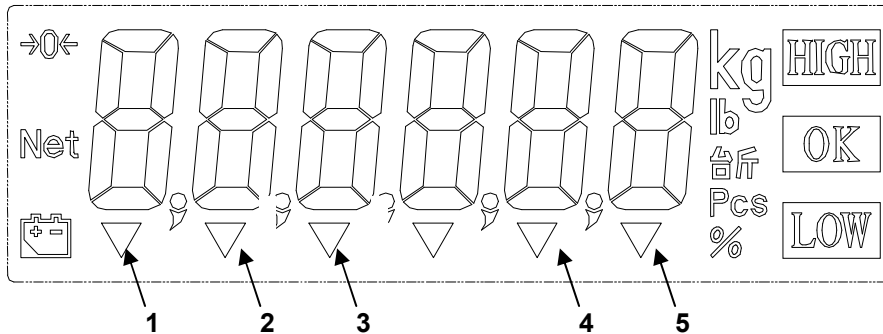

HIGH : Preset High Limit Weight Value

OK : The range between Low & High Limit Weight Value

LOW : Preset Low Limit Weight Value

kg : “kg” unit

lb : “lb” unit

Pcs : “COUNTING” mode indicating the number of pieces

à 0B : “ZERO” indication and platform stable confirmation

Net : “Net Weight ”indication

 : “Low Battery” indication

61 : (STABLE) “Stable” indication

62 : (PT) “Pre-set Tare” mode











63 : (M+) “Accumulation” mode

64 : () “Sample Too Small” indication

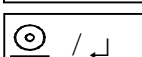

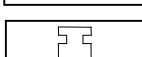
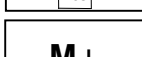
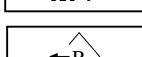
65 : () “Piece Weight Too Small” indication

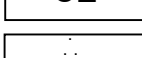

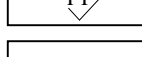
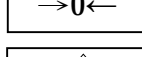







KEYBOARD FUNCTION

1.  : Units Key to choose the desired unit weight (kg or lb).
2.  : Preset High & Low Limit value.
3.  :  ⇒ Data Entry Key,  ⇒ Backlight Key.
4.  :  ⇒ Print Key to print the total data ;  ⇒ Confirmation Key.
5.  : Sample Key to set the sample quantity.
6.  : Accumulation Key to add the displayed value into memory.
7.  : Re-call accumulated or preset high & low limit values or preset tare value.
8.  : Clear Key to delete the existing accumulated values.
9.  : Press this key to enter the counting mode.
10.  : Preset Tare Key.
11.  : Zero Key to re-zero the scale.
12.  : Tare Key to deduct the container weight.

KEYBOARD SYMBOLS:

COUNT	SMPL	UNITS
PRE-TATR	M+	PST
ZERO	RE-CALL	
TARE	CE	

⇒

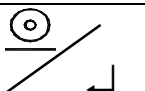
		UNITS
	M+	
		
	CE	



OPERATION

1. DISPLAY BACKLIGHT

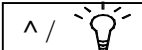
Press the  key to choose the desired display backlight mode:

 ⇒ “Auto Backlight” mode. When the weight is over 10 divisions or any key is pressed, the display backlight will be switched on. When the weight returns to zero or the weight on platform is less than 10 divisions, the display backlight will switch off after 5 seconds.

 ⇒ Display backlight is on all the time.

 ⇒ Display backlight is off.

2. ZERO

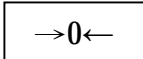
Press the  key to re-zero the display with no load on the weigh pan. When zero is set, the (à 0.0) symbol will be displayed.

3. WEIGHING MODE

(1). Units Selection

1. Press the  key in the weighing mode to choose the desired weighing unit and the display will show the “kg” or “lb” symbol on the top right of the LCD display.
2. The unit status will be memorized when turning the machine off.

(2). Totalising

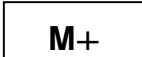
1. The scale allows the next totalising operation, even when the weight value does not return back to zero. The  key is functional, when the weight value changes by more than 10 d. The scale will store the totalised weight value after the weight is stable.
2. The scale can totalise positive or negative weight but not both at the same time. The totalised weight store must be reset to zero before it is possible to select positive or negative totalising mode.



I. Weight Totalising

ACTION

DISPLAY

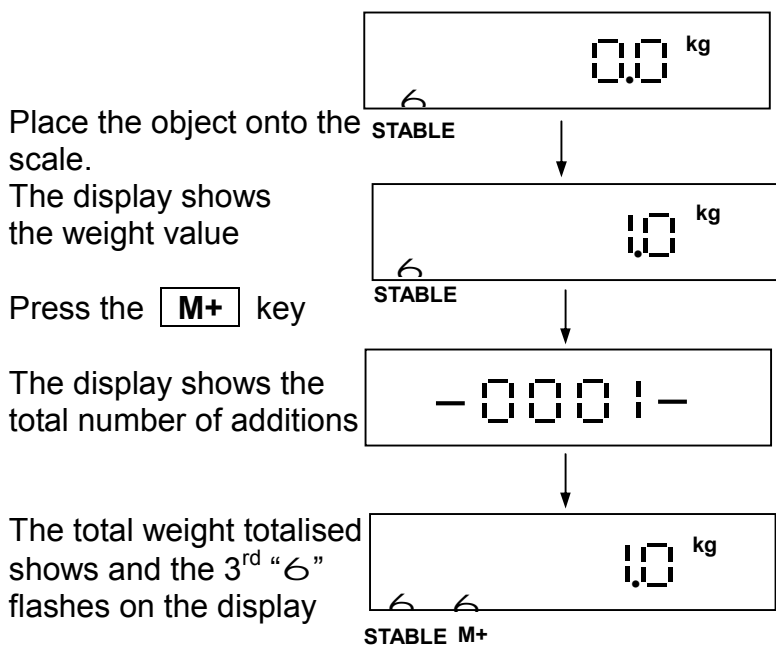

- ✓ The totalising function can be used up to a maximum of 9999 times before it must be reset. The totalising display is limited to 6 digits maximum.

II. Recall Totalised Weight Values

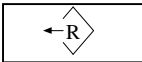
1. Press the  key to display the total number of additions and the totalised weight value. The 3rd "6" symbol located above (M+) icon will flash on the display. The scale will return to the weighing mode after 3 seconds.

- ✓ The scale will not display the negative sign "-" for negative totalised weight values when recalling an a totalised weight value, but the negative sign "-" will be printed out (transmitted serially) for each negative weight and negative totalised weight.

III. Clear Totalised Weight Values

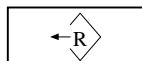
1. Press the  key followed by pressing the **CE** key to clear the totalised weight values.
2. All totals will be lost in the following three circumstances:
 - ◆ The mode is changed from weighing to counting or vice versa.
 - ◆ The scale is switched off.
 - ◆ The weight unit is changed.



(3). Deduction of the Container Weight

I. The weight of the container is unknown (Tare)

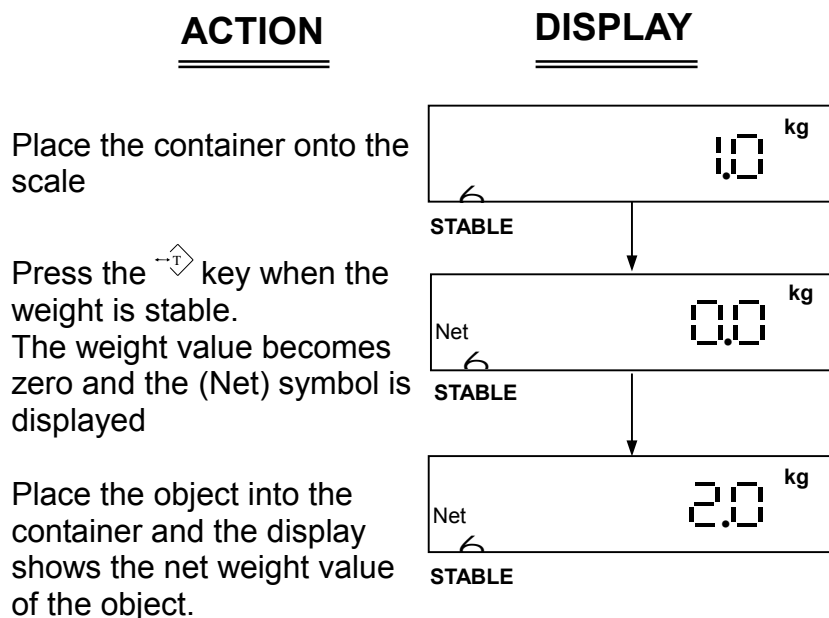

II. Recall the semi-auto tare value

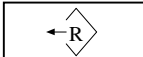
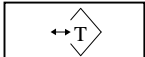
Press the  key followed by pressing the  key ⇒ The display shows the tare weight value.

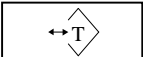

III. Clear the semi-auto tare

When the container is removed from the scale, the display shows the container weight value with a negative sign. Press the  key to reset the scale to zero, and the (Net) symbol will switch off.

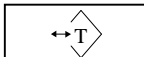
NOTE:

- ✓ Multiple tare operation ⇒ Users can continuously increase or decrease the tare value by pressing the  key.
- ✓ The total tare value (tare value + pre-set tare value) can equal the full capacity of the scale.

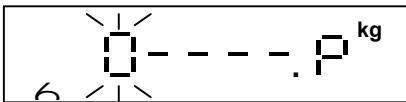
**IV. The weight of the container is known (Pre-set tare)**

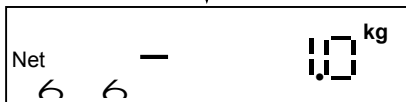
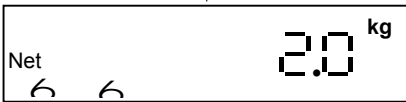
<u>ACTION</u>	<u>DISPLAY</u>	<u>DESCRIPTION</u>
Press the  key		The display shows the weight value of the container with the negative sign and the (Net) symbol. The second “6” above the (PT) icon indicates the tare is active
Use the  key to enter the weight value of the container followed by pressing the  key		
Place the object with the container onto the weight pan. The display shows the net value of the object		

V. Recall the pre-set tare value

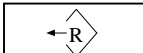
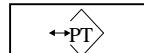
Press the  key followed by pressing the  key ⇒ The display shows the pre-set tare value.

VI. Clear the pre-set tare value

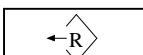
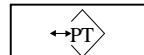
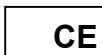
Press the  key followed by pressing the  key, then press the  key to clear the pre-set tare value. The scale resets back to zero, and the (Net) symbol and the second “6” icon (PT) will switch off.

NOTE:

- ✓ In Tare mode, the Preset tare function is disabled.
- ✓ The scales with two weighing ranges can NOT pre-set the tare value larger than the first weighing range. For example: a 30kg scale is set by two weighing ranges. The first range is 0 to 15kg, and the second range is 15 to 30kg. The pre-set tare value can not be larger than 15kg.









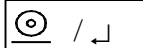

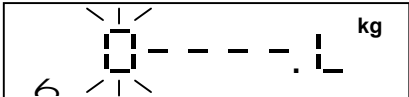

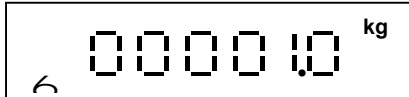

(4). Check Weighing

Press the  key to enter the check weighing function. Press the **UNITS** key to return back to the weighing mode.

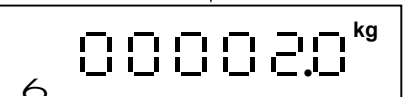
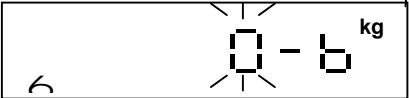
1. Pre-set the "Low limit value", "High limit value", and "the buzzer" operation

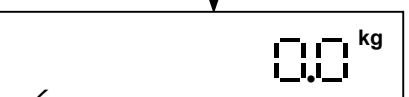
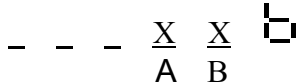
Press the  key to enter the value required and step to the next digit by pressing the  key.

<u>ACTION</u>	<u>DISPLAY</u>	<u>DESCRIPTION</u>
Press the  key to select the check weighing function		
Set the "Low limit value"		
Press the  key to enter the Low limit value. Press the  key to confirm the setting		
Set the "High limit value"		
Press the  key to enter the High limit value. Press the  key to confirm the setting		
Set the "buzzer" operation		
Press the  key to set the buzzer operation. Press the  key to confirm the setting		
The scale returns to the weighing mode.		
		
		
		<p>Buzzer Setting</p> <p></p> <p>A ⇒ 0 = When the weight is stable the buzzer sounds and the High, OK or Low icon is displayed.</p> <p>1 = The High, OK or Low icon is displayed irrespective of the stability of the weight. The buzzer sounds only when the weight is stable.</p> <p>2 = The buzzer sounds and the High, OK or Low icon is displayed irrespective of the stability of the weight.</p> <p>B ⇒ 0 = The buzzer does not sound.</p> <p>1 = The buzzer sounds at the OK status.</p> <p>2 = The buzzer sounds when the weight of the object is lower or equal to the lower limit value, or higher than the upper limit value.</p>
<div style="border: 1px solid black; padding: 5px;">  key = Upward key (0~9 digit entry)  key = Confirmation key (move the cursor one step to the right) </div>		



II. Pre-set the Low limit value only

After completing the Low limit value setting, the display shows . Press the

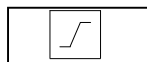

key to complete the setting, and the display shows

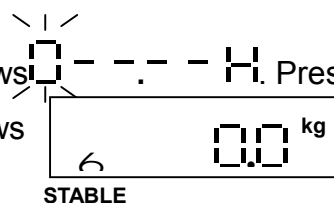

- ✓ When users only pre-set the Low limit value, the buzzer setting is fixed at:

III. High/OK/Low indications

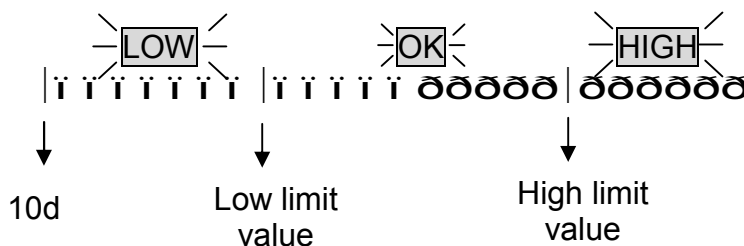

IV. Recall the check weighing setting

1. Press the key followed by pressing the key to recall the Low limit value.
2. Then press the key again to recall the High limit value.
3. Then press the key again to recall the buzzer setting.
4. Then press the key again to return the weighing mode.

V. Clear the check weighing settings

1. Press the key followed by pressing the key, and then press the key to clear the Low limit value.
2. Press the key again to clear the High limit value and the buzzer setting.



4. COUNTING FUNCTION

Press the  key to enter the counting function. Press the **UNITS** key to return back to the weighing mode.

(1). Sampling

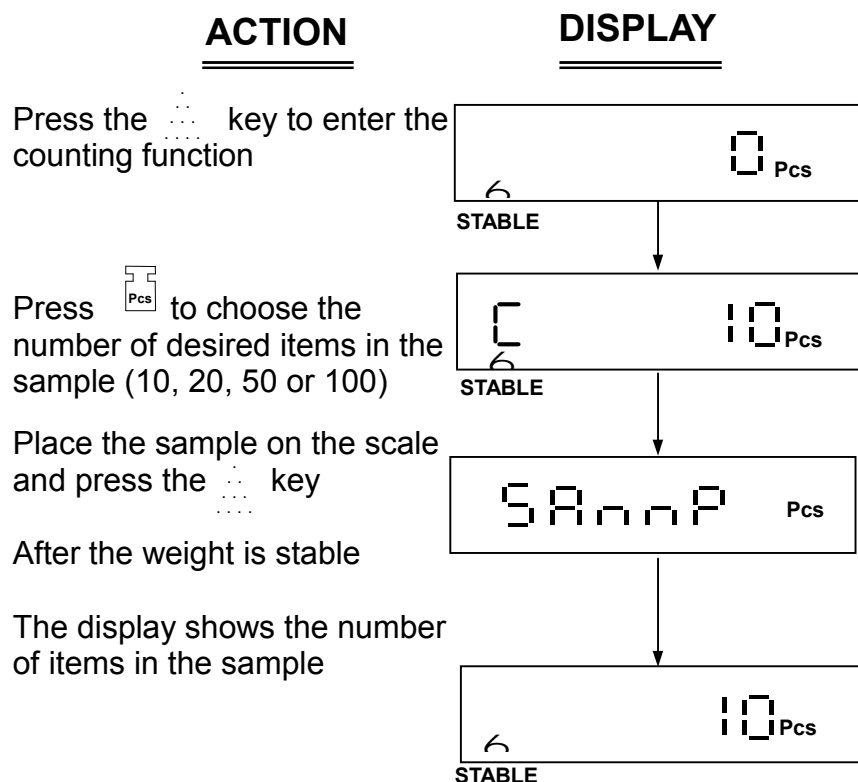

NOTE:

- ✓ The larger the sample size, the more accurate the unit weight. (The minimum sample weight = 20d)
- ✓ A sample size of 10 pieces gives a typical count accuracy of 95%.
- ✓ A sample size of 50 pieces gives a typical count accuracy of 98%.

SAMPLE TOO SMALL () ⇒ Sample is less than 20 divisions.

UNIT WEIGHT TOO SMALL () ⇒ Unit weight is less than 1/5 of a division.

Under such conditions, the scale can still work, but may result in lower count accuracy.

(2). Totalising

Refer to the operation of totalising in the weighing function on page 9.

(3). Check Weighing

Refer to the operation of check weighing function on page 13.



1. CHECK-WEIGHING CONFIGURATION F4

- ◆ F8 (Hold) affects access to F4. If F8 is set, access to F4 is denied.

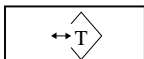
Press the  or  key to select the **F4** function ⇒ the display shows **F4**

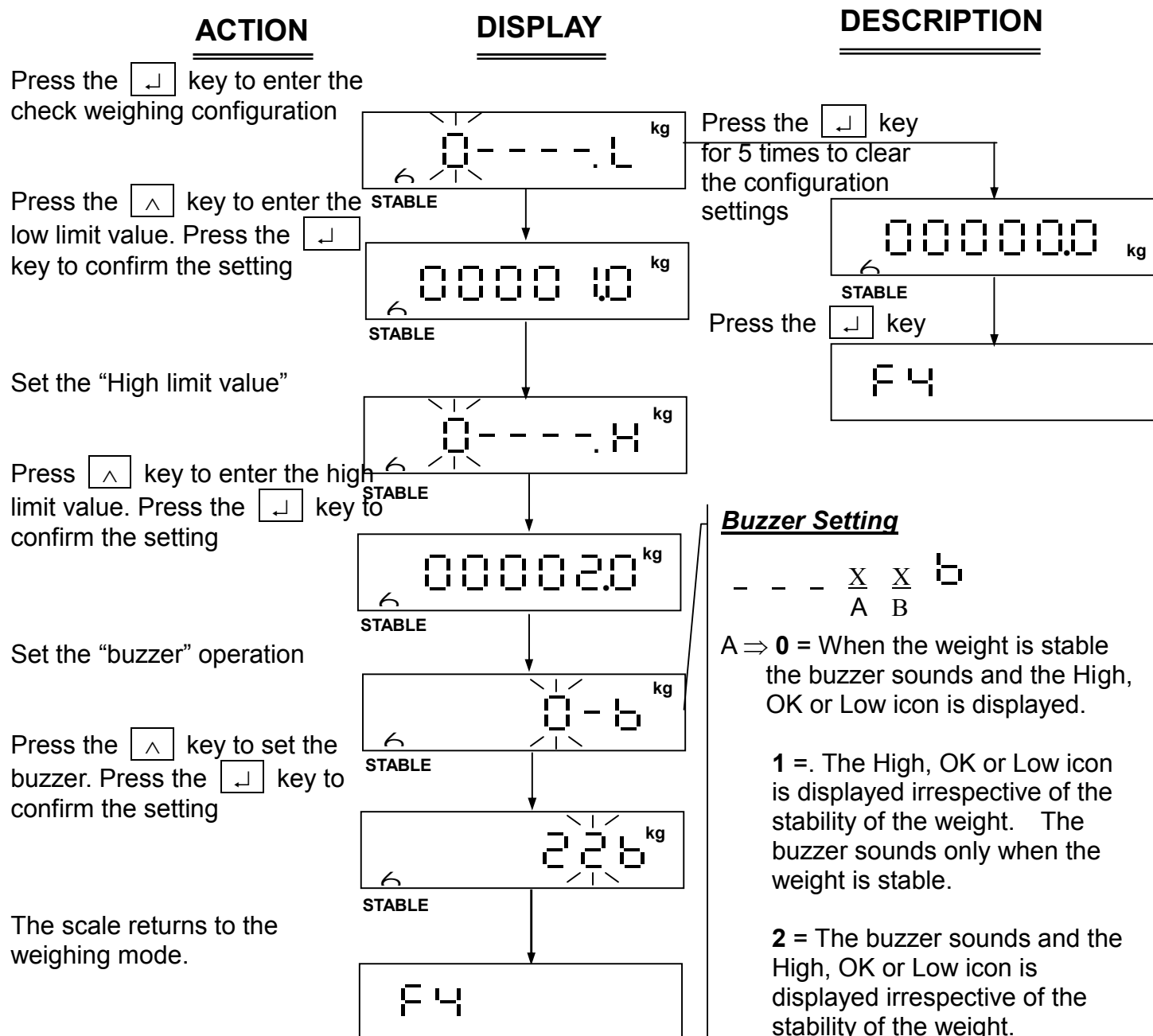

Buzzer Setting

— — — $\frac{X}{A}$ $\frac{X}{B}$ b

A ⇒ 0 = When the weight is stable the buzzer sounds and the High, OK or Low icon is displayed.

1 = The High, OK or Low icon is displayed irrespective of the stability of the weight. The buzzer sounds only when the weight is stable.

2 = The buzzer sounds and the High, OK or Low icon is displayed irrespective of the stability of the weight.

B ⇒ 0 = The buzzer does not sound.

1 = The buzzer sounds at the OK status.

2 = The buzzer sounds when the weight of the object is lower or equal to the low limit value, or higher than the high limit value.

 key = Upward key (0~9 digit entry)

 key = Confirmation key







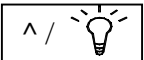

(move the cursor one step to the right)



2. RS-232 SETTING F5

- ◆ J1 and J3 on the RS-232 interface are connected together (short), when the RS-232 interface is connected to a computer.
- ◆ J2 and J4 on the RS-232 interface are connected together (short), when the RS-232 interface is connected to a printer.

Press the  or  keys to select the **F5** function ⇒ the display shows **F5**

<u>ACTION</u>	<u>DISPLAY</u>	<u>DESCRIPTION</u>
Press the  key	F5	
Transmission mode	r n P 0	r n P 0 ⇒ No transmission r n P 1 ⇒ Stable transmission r n P 2 ⇒ Continuous transmission r n P 3 ⇒ Press the  key to transmit (simple mode) r n P 4 ⇒ Press the  key to transmit (complete mode) r n P 5 ⇒ Stable transmission (totalising mode). The format is as same as r n P 3 . r n P 6 ⇒ EZ-2 printer mode The format is as same as r n P 4 . r n P 7 ⇒ EZ-2 printer mode. Press the  key to transmit r n P 8 ⇒ Press the  key to transmit. The format is the same as r n P 1 & 2 .
Press the  key to set the transmission mode Then press the  key to confirm the setting	r n P 4	
Baud rate default setting	2400	
Press the  key to set the baud rate (1200, 2400, 4800 or 9600) Then press the  key to confirm the setting	9600	
Configuration complete	F5	

✓ When choosing “EZ-2 printer mode”, the baud rate should be set to 9600 Baud



3. EXIT CONFIGURATION SETTINGS F6

Press the  or  key to select the F6 function⇒ the display shows F6

ACTION

DISPLAY

Press the  key

F6

Scale reverts back to the weighing mode



RS-232 AND RELAY OUTPUT

1. RS-232 OR SERIAL PRINTER OUTPUT

(1) RS-232 (25 Pin 'D' type) Pin Description

· J1 - J3 SHORT ; J2 - J4 OPEN (default setting)

Pin 2 ⇒ RXD

Pin 3 ⇒ TXD

Pin 7 ⇒ GND

· J2 - J4 SHORT ; J1 - J2 OPEN

Pin 2 ⇒ TXD

Pin 3 ⇒ RXD

Pin 7 ⇒ GND

✓ Please refer to F5 function settings for transmission mode, baud rate setting and data format.

(2) RS-232 Interface Format

I . Mode : EIA-RS232 C's

II . Format :

1. Baud rate: 1200, 2400, 4800 or 9600
2. Data bits: 8 BITS
3. Parity bit: None
4. Stop bits: 1 BIT
5. Code: ASCII

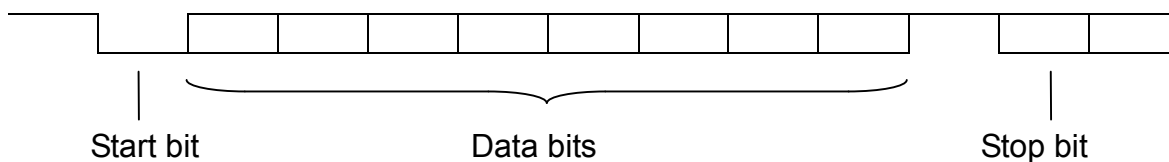



(3) Data Format

Stable transmission (┌ ┌ P 1) / Continuous transmission (┌ ┌ P 2)
 Press the key to transmit (┌ ┌ P 8)

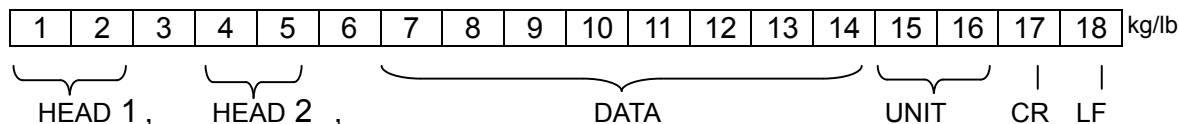

HEAD 1 (2 BYTES)		HEAD 2 (2 BYTES)	
OL	- Overload , Under load	TR	- TARE Mode
ST	- Display is Stable	NT	- NET Mode
US	- Display is Unstable	GS	- GROSS Mode

DATA (8 or 9 BYTES)

2D (HEX) = “ - ” (MINUS)

2E (HEX) = “ . ” (DECIMAL POINT)

UNIT (2, 3 or 4 BYTES)

kg = 6B (HEX) ; 67 (HEX)

lb = 6C (HEX) ; 62 (HEX)

tl.T = 74 (HEX) ; 6C (HEX) ; 2E (HEX) ; 54 (HEX)

hkg = 68 (HEX) ; 6B (HEX) ; 67 (HEX)

Transmission example:

1. The gross weight (+0.876kg) shows as below, after stable: (in the tare mode)

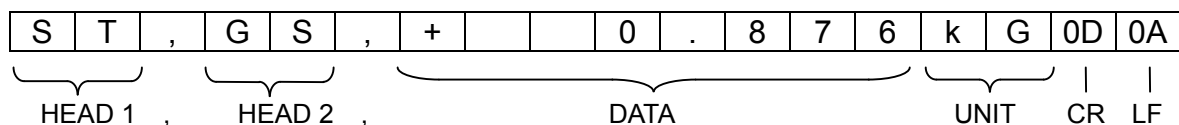

2. The net weight (-1.568lb) shows as below without weight stability: (Not in the tare mode)

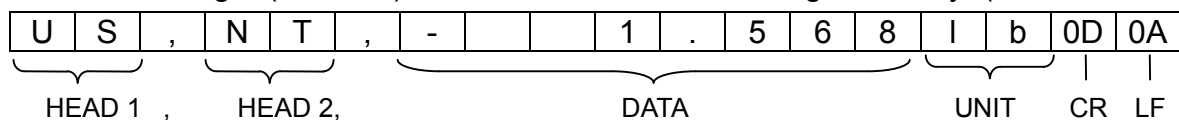

3. The net weight (+0.876kg) shows as below, after stable: (in the tare mode)

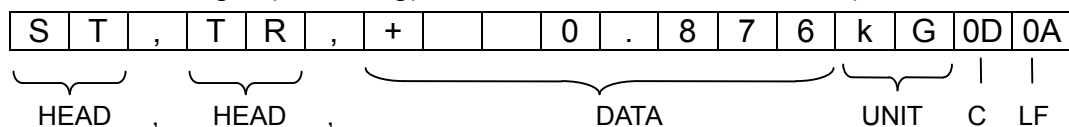



Press the key to transmit (simple mode)

S/N WT/UNIT (kg / lb)

0001 1.0000 E Press the key or the key

0002 1.0000 E Press the key or the key

0003 1.0000 E Press the key or the key

0004 1.0000 E Press the key or the key

0005 1.0000 E Press the key or the key

0005 5.0000 E Press the key for 2 times to printout the total

Stable transmission (totalising mode)

S/N WT/UNIT (kg / lb)

0001 1.0000 E scale stable, transmitting

0002 1.0000 E scale stable, transmitting

0003 1.0000 E scale stable, transmitting

0004 1.0000 E scale stable, transmitting

0005 1.0000 E scale stable, transmitting

0005 5.0000 E Press the key for 2 times to printout the total

EZ-2 printer mode, press the key to transmit

(Baud rate must be set at 9600)

Only prints out the “weight value”. The proportion of the printed typeface ⇒ Height : Width = 3:2

+100.0 kg



EZ-2 printing mode (Baud rate must be set to 9600). Press the key to transmit (complete mode)

TICKET	NO .0001	E	Press the key or the M+ key
G	1.000kg		
T	0.000kg		
PT	0.000kg		
N	1.000kg		

(Blank line x 3)

TICKET	NO .0002	E	Press the key or the M+ key
G	1.000kg		
T	0.000kg		
PT	0.000kg		
N	1.000kg		

(Blank line x 3)

TICKET	NO .0003	E	Press the key or the M+ key
G	1.000kg		
T	0.000kg		
PT	0.000kg		
N	1.000kg		

(Blank line x 3)

TOTAL NUMBER		E	Press the key twice to print out the total
OF TICKETS	0003		
TOTAL			
NET	3.000 kg		

(Blank line x 3)

<Remarks> : G = GROSS T = TARE PT = PRE-TARE N = NET



2. RELAY OUTPUT

(1) Relay Output

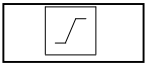
Relay's function acts as signal output in the check-weighing mode. When an object's weight value reaches one of the setting points (HI, OK, LOW), the relay outputs a signal through PIN 1, PIN2, or PIN 3. To set the check-weighing configuration by pressing the  key (in TW & AW models) or enter F4 (please refer to page 12 or 16 for operations).

(2) Relay Pin Description

- PIN 1 ⇒ OK output
- PIN 2 ⇒ High output
- PIN 3 ⇒ Low output
- PIN 4 ⇒ VDD
- PIN 5 ⇒ GND
- PIN 6 ⇒ COMMON

(3) Connection Illustration

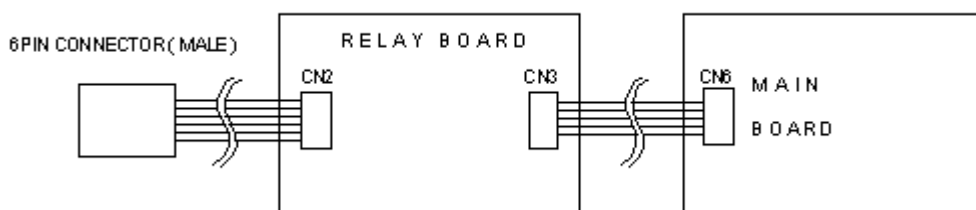



(4) Power Source Illustration

The relay circuit board can be supplied either by the external AC power or internal DC power.

- Relay powered by external AC power
PIN4 and PIN5 are connected with AC power source; J1 and J2 OPEN

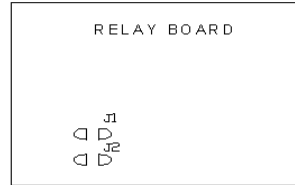

- Relay powered by internal DC power
No power source input to PIN4 and PIN5; J1 and J2 SHORT

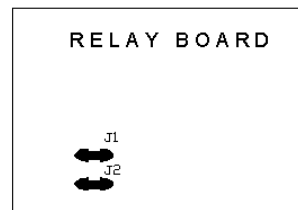

(5) Connection Setting

OK, High, Low can be set at **NO** (normal open status) or **NC** (normal close status) respectively.

- OK、High、Low at **NO** (normal open status) ⇒ default setting

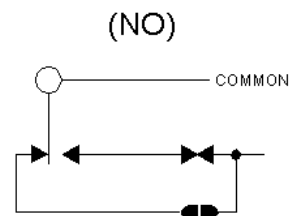
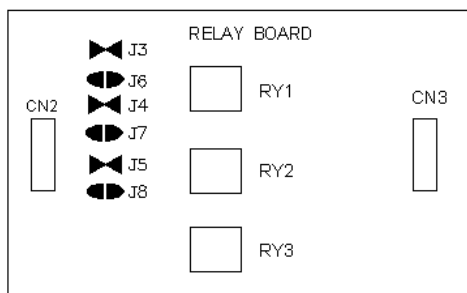

- OK、High、Low at **NC**(normal close status)

Please use a knife to cut the J3, J4 and J5 not connect (open) and solder the J6, J7 and J8 connected.

