



# Digital Mailing System DM500™ and DM550™



**Operator Guide**

US English Version



SV60890 Rev. G ©2005 Pitney Bowes Inc.

All rights reserved. This book may not be reproduced in whole or in part in any fashion or stored in a retrieval system of any type or transmitted by any means, electronically or mechanically, without the express, written permission of Pitney Bowes.

We have made every reasonable effort to ensure the accuracy and usefulness of this manual; however, we cannot assume responsibility for errors or omissions or liability for the misuse or misapplication of our products.

Due to our continuing program of product improvement, equipment and material specifications as well as performance features are subject to change without notice. Your postage meter may not have some of the features described in this book.

AccuTrac, Ascent, DM500, DM550, DM Series, E-Z Seal, IntelliLink, Postage By Phone, and Pitney Bowes Supply Line are trademarks or registered trademarks of Pitney Bowes Inc. ENERGY STAR is a registered trademark of the United States Environmental Protection Agency. All other trademarks are trademarks or registered trademarks of the respective owners.

## Alerting Messages

Various messages are used throughout this guide to alert you to potentially hazardous or error causing conditions. These messages are as follows:



**WARNING!** Alerts you to conditions or practices that could cause serious injury.

---



**CAUTION:** Alerts you to conditions or practices that could cause damage to the equipment or to the material being run.

---

**IMPORTANT!** Alerts you to conditions or practices that could adversely affect equipment operation if instructions are not followed exactly.

---

**NOTE:** Provides a comment or explanation of the associated topic.

---

## FCC Compliance

This equipment has been tested and found to comply with the limits for a Class A digital device, pursuant to part 15 of the FCC rules. These limits are designed to provide reasonable protection against interference when the equipment is operated in a commercial environment. This equipment generates, uses, and can radiate radio frequency energy and, if not installed and used in accordance with the instruction manual, may cause interference to radio communications. Operation of this equipment in a residential area is likely to cause interference, in which case the user will be required to correct the interference at his own expense.

Use only a shielded interface cable to operate this equipment with a scale or other peripheral device.



**CAUTION:** Changes or modifications to this equipment not expressly approved by the party responsible for compliance (Pitney Bowes) could void the user's authority to operate the equipment.

---

## FCC Compliance of Modem

This equipment complies with Part 68 of FCC rules. The label on the equipment cover shows the FCC registration number and the ringer equivalence number (REN) for the modem. If requested, this information must be provided to the telephone company. This equipment is designed to connect to a two-wire, local switch, access loop start (Facility Interface Code 02LS2) with a standard RJ11C interface.

The REN is used to determine the quantity of devices that may be connected to the telephone line. Excessive RENs on the telephone line may result in the devices not ringing in response to an incoming call. In most, but not all areas, the sum of the RENs should not exceed five. To be certain of the number of devices that may be connected to the line, contact the telephone company to determine the maximum REN for your calling area.

If this modem causes harm to the telephone network, the telephone company may discontinue your service temporarily. You will be notified in advance or as soon as possible. You will be advised of your right to register a complaint with the FCC. If the user experiences trouble using this equipment, the user shall disconnect the equipment from the telephone line to determine if the equipment is malfunctioning. If the equipment is malfunctioning, the use of the equipment shall be discontinued until the problem is corrected.

The telephone company may make changes to its facilities, equipment operations, or procedures that could affect the operation of this equipment. In this event, the telephone company will provide advance notice for you to make necessary modifications to maintain uninterrupted service.

If you experience trouble with this modem, please refer to the warranty information provided with this equipment. If the trouble is causing harm to the network, the telephone company may request that you remove the equipment from the network until the problem is resolved.

This equipment may not be used with party lines or coin lines.

This equipment is not intended to be serviceable. Please refer to the warranty information if problems occur. Failed units will be withdrawn by approved Pitney Bowes service engineers and returned to the U.S. Service Center. For reference purposes, the U.S. Service Center contact address is: Pitney Bowes Inc., Walter Wheeler Drive, Stamford, CT 06926-0700.



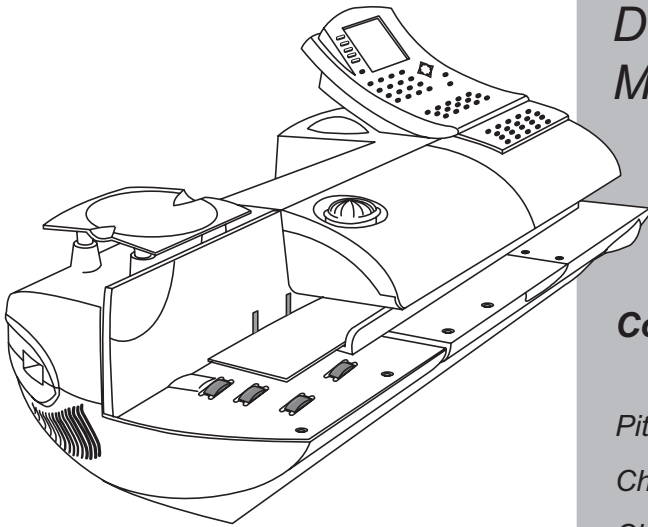

# *DM500™ and DM550™ Digital Mailing System Operating Guide*

## **Contents**

*Pitney Bowes Contact Information List*

*Chapter 1 - Read this First*

*Chapter 2 - Meet the DM500™ and DM550™ Mailing System*

*Chapter 3 - Mail in a Minute*

*Chapter 4 - Running Mail*

*Chapter 5 - Mailing System Setup*

*Chapter 6 - Adding Postage*

*Chapter 7 - Accounting Setup*

*Chapter 8 - Reports*

*Chapter 9 - Maintaining and Updating*

*Chapter 10 - Troubleshooting*

*Chapter 11 - Supplies and Options*

*Appendix A - Glossary*

*Appendix B - Operator Training Checklist*

*Appendix C - Specifications*

*Index*





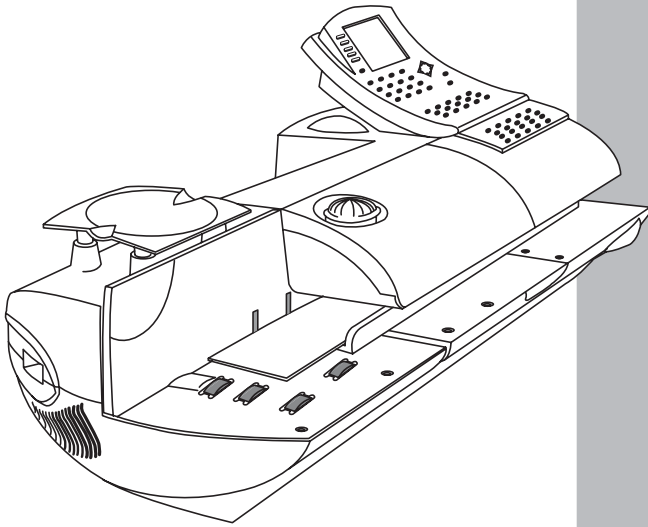

## *Pitney Bowes Contact Information List*

### **Pitney Bowes Web Sites**

- For frequently asked questions, go to:  
*<http://www.pb.com>*
- To place requests for service or training, go to:  
*<http://www.pb.com>* and click on **My Account**.
- To order Pitney Bowes supplies and accessories, go to:  
*<http://www.pb.com>* and click on **Online Store**.
- To view and pay invoices online, go to:  
*<http://www.pb.com>* and click on **My Account**.
- To view inventory, go to:  
*<http://www.pb.com>* and click on **My Account**.
- To add postage to your Postage By Phone® Meter Payment System account, go to:  
*<http://www.pb.com>* and click on **Add Postage to Your Meter**.

### **Our Help Desk**

For direct questions, call: 1.800.522.0020.  
Customer Service Representatives are available Monday through Friday, 8AM - 8:00PM EST.

### **Postage By Phone® System**

To contact, call 1.800.243.7800.

### **Pitney Bowes Supplies**

To order Pitney Bowes approved supplies, call our Pitney Bowes Supply Line™ at 1.800.243.7824.



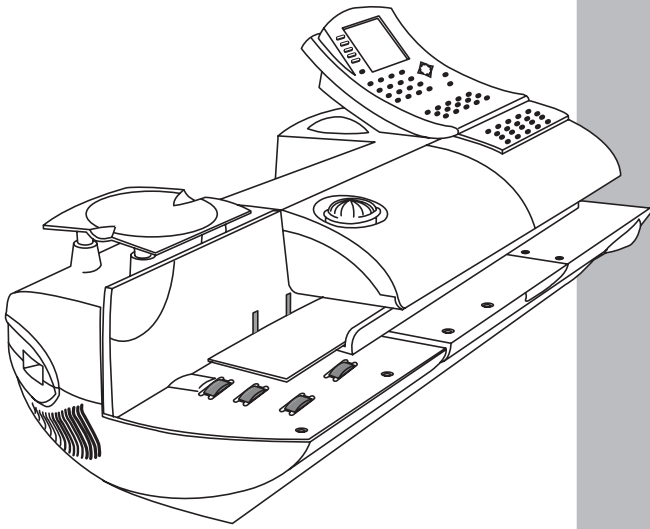

# 1 *Read This First*

## *Contents*

<i>What's in This Guide</i> .....	1-2
<i>Other Information Available</i> .....	1-3
<i>What You Need to Know</i> .....	1-4
<i>Safety Requirements</i> .....	1-5
<i>Important Information About Powering Your DM Series™ Digital Mailing System Off</i> .....	1-8

### What's in This Guide

**Chapter 1 - Read this First** contains important information about USPS requirements and equipment and telephone safety precautions.

**Chapter 2 - Meet the DM500™ and DM550™ Digital Mailing System** gives an overview of the mailing system and the location of each control and machine feature. Please read this section carefully. It provides a foundation for the instructions in later sections of this book.

**Chapter 3 - Mail in a Minute** explains the basics of running mail on your system. By following these instructions, you will be able to run mail quickly.

**Chapter 4 - Running Mail** explains how to run mail in the different mail modes as well as when to use the various options.

**Chapter 5 - Mailing System Setup** provides step-by-step instructions for customizing your mailing system to suit your needs.

**Chapter 6 - Adding Postage** explains how to add postage funds to your postage meter (Postal Security Device) using the Pitney Bowes Postage By Phone® Meter Payment system.

**Chapter 7 - Accounting Setup** explains how to set up accounts to track postage.

**Chapter 8 - Reports** explains the different types of reports available and how to print them.

**Chapter 9 - Maintaining and Updating** explains how to check the quality of the meter stamp and how to take care of the moistener and tape feeder. It also tells you how to add features and update postal rates and carriers.

**Chapter 10 - Troubleshooting** contains a list of problems you may encounter while using your mailing system.

**Chapter 11 - Supplies and Options** lists the supplies available for your system and how to order them.

**Appendix A - Glossary** defines mailing terms used throughout this operator guide.

**Appendix B - Operator Training Checklist** is a list of procedures the Pitney Bowes representative will review with you during the installation of your mailing system.

**Appendix C - Specifications** contains the specifications for the mailing system and mailing materials.

## Other Information

This section describes other sources of information available for the DM500™ and DM550™ Digital Mailing System.

## Publications

### ***Scale User Guide***

If you purchase an attached scale, read this guide if you have questions about its operation.

## On the System

### ***Quick Reference Cards (SV60801)***

Much of the information contained in the Operator guide, such as how to set postage, process mail, or clear jams is summarized in the Quick Reference Card Set. The cards are located in a slot in the Stacker module of your system.

## Web Resources

### ***Our Help Desk***

For a list of the Pitney Bowes web sites, refer to the *Pitney Bowes Contact Information List* located at the front of this guide.

### **What You Need to Know**

Since your postage meter (Postal Security Device) is licensed by the United States Postal Service (USPS), you must follow a few basic requirements.

#### ***USPS Requirements***

- Mail must have the correct date and postage amount in the meter stamp.
- Metered mail must bear the ZIP Code location of the post office where the postage meter (Postal Security Device) is registered.
- If you move to another ZIP Code location, you must update the ZIP Code. You can do this by calling your local Pitney Bowes district office.
- Each time you refill your postage meter (Postal Security Device) through the modem, the Postage By Phone® Meter Payment System computer automatically performs a postal inspection. If the postage meter in your mailing machine has not detected a modem refill transaction at certain intervals, the message “Inspection Required” appears on the main screen of the IntelliLink® Control Center. (The system will then prompt you to connect to Pitney Bowes and perform an inspection.)
- The postage tape you use must meet USPS specifications.

## Safety Requirements



**WARNING!** Follow normal safety precautions for all office equipment whenever using your mailing system.

---

- Read all instructions before you attempt to operate the machine.
- Use the equipment only for its intended purpose.
- Place the machine near an easily accessible power outlet. Avoid using outlets controlled by wall switches or shared by other equipment.
- Plug the machine into a properly grounded power outlet. DO NOT remove the power cord's ground pin and DO NOT use a ground adapter.
- Make sure the area in front of the power outlet is free of obstruction.
- Turn the machine off using the power switch (for the location, refer to *Chapter 2, page 2-6*) and NOT from a power strip.
- Do not place lighted candles, cigarettes, cigars, etc. on the machine.
- DO NOT route the power cord over sharp edges or trap it between pieces of furniture. Make sure there is no strain on it.
- To reduce the risk of fire or electrical shock, DO NOT attempt to remove covers or disassemble the equipment. The housing encloses hazardous parts. If any components are dropped or otherwise damaged, report such damage to your Pitney Bowes customer service representative.
- Keep fingers, long hair, jewelry, neck ties, and loose clothing away from moving parts at all times.
- When removing jammed material, avoid using too much force to prevent personal injury and damaging equipment.
- To prevent overheating do not cover system vent openings.
- When lifting covers, wait for all parts to stop moving before placing hands near feeder path or printer.
- Do not remove covers as they enclose hazardous parts that should only be accessed by a Pitney Bowes Service Representative.
- Use only Pitney Bowes approved supplies, e.g., inks, tapes, and cleaners. Call the Pitney Bowes Supply Line™ listed in the *Pitney Bowes Contact Information List* at the front of this guide.
- Always follow the specific occupational safety and health standards prescribed for your workplace.

### Safety Requirements

continued

---

**NOTE:** Your mailing system requires annual cleaning by a Pitney Bowes service representative. For continued safe operation, contact your local Pitney Bowes office for a scheduled cleaning.

---

If you use an AC adapter to power the meter when it is off the mailing machine base:

- Use only the AC adapter designed specifically for the IntelliLink® Control Center on the back of the DM500™ and DM550™ Digital Mailing System. Third-party AC adapters may damage the IntelliLink® Control Center.
- To protect against electrical shock, plug the AC adapter into a properly grounded power outlet.
- Do not route the AC adapter cable over sharp edges or trap between furniture.



**CAUTION:** In case of an ink spill, leaking ink or excessive ink accumulation, immediately power down and disconnect the power cord from the wall plug and call your local Pitney Bowes office for a cleaning.

---

The IntelliLink® Control Center and its built-in postage meter (Postal Security Device) connect directly to analog telephone lines. For your protection we urge you to follow basic safety precautions to reduce the risk of fire, electric shock and injury to persons, as well as the following:

- Never connect telephone wiring during a lightning storm.
- Disconnect the meter telephone line during a lightning storm.
- Avoid using a telephone or equipment that connects to a telephone line during an electrical storm; there may be a remote risk of electrical shock from lightning.
- Never install telephone jacks in wet locations.
- Do not use this product near water, for example, near a bath tub, wash bowl, kitchen sink or laundry tub, in a wet basement or near a swimming pool.
- Never touch non-insulated telephone wires or terminals unless the telephone line has been disconnected at the network interface.
- Use caution when installing or modifying telephone lines.
- Do not use the telephone or equipment connected to the telephone line in the vicinity of a gas leak.



## Safety Requirements

continued

- Do not connect your postage meter (Postal Security Device) to a digital phone line. The device's built-in modem is designed to work with an analog phone line only. (Your fax machine is usually connected to an analog phone line.) If you do not know if your line is digital, call your phone provider for verification.
- Disconnect the telephone cord from the wall before removing the IntelliLink® Control Center.



**CAUTION:** To reduce the risk of fire, use only 26 AWG telecommunication line cord either supplied with the machine or separately.

---



## Important Information About Powering Your DM Series™ Digital Mailing System Off

Your DM Series™ Digital Mailing System is designed to remain powered on at all times. This is necessary so that the printer station can perform the required maintenance it needs to maintain peak performance.

Your DM Series™ System has a power switch (for the location, refer to *Chapter 2, page 2-6*) so that you can properly remove power to the system.

If you need to power off your system, you must use the power switch. When you power off the system, the system immediately moves the print-head back to the capping station to keep the printhead from drying out.

Powering off your system by any other means, such as a wall switch, a power strip, or unplugging from a wall outlet, will result in higher than normal ink consumption and could damage your mailing system.

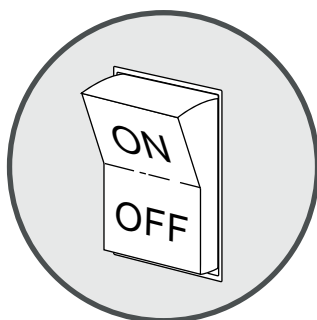

YES

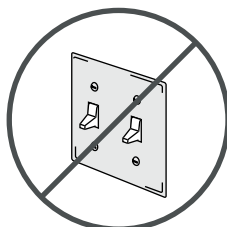

NO

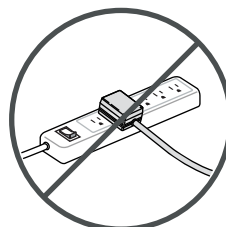

NO

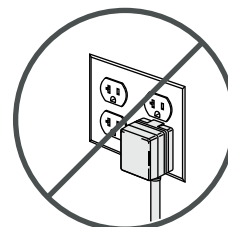

NO

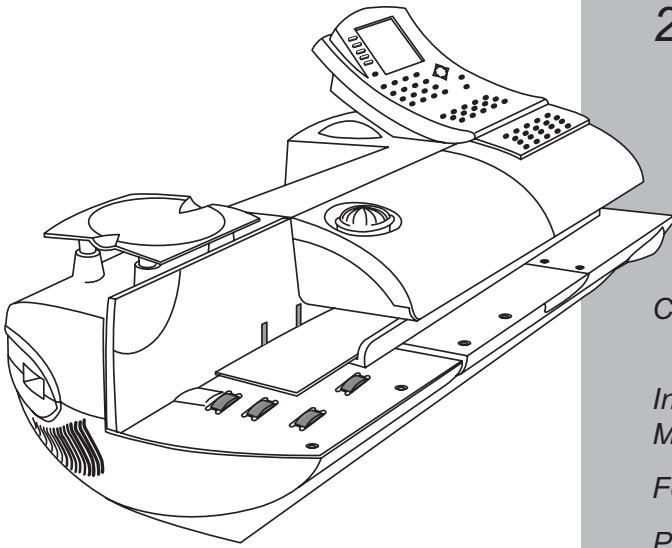

## 2 Meet the DM500™ and DM550™ Digital Mailing System

### Contents

<i>Introducing the DM500™ and DM550™ Digital Mailing System</i> .....	2-2
<i>Features and Benefits</i> .....	2-2
<i>Parts of the Mailing System</i> .....	2-5
<i>Mailing System Exterior</i> .....	2-5
<i>Connecting the IntelliLink® Control Center to a Remote Analog Line</i> .....	2-9
<i>Mailing System Interior</i> .....	2-10
<i>The IntelliLink® Control Center</i> .....	2-12
<i>The Main Screen</i> .....	2-14

## 2 • Meet the DM500™ and DM550™ Digital Mailing System

---

### Introducing the Mailing System

The DM500™ and DM550™ System is an easy-to-use digital mailing system you can tailor to satisfy the unique requirements of your organization. This system:

- Automatically feeds a stack of mail.
- Moistens and seals the envelope flaps.
- Imprints the correct postage amount.
- Stacks the finished mail.

### Features and Benefits

The following section provides a summary of the main features and benefits of the DM500™ and DM550™ Systems.

### Energy Star® Rating



As an ENERGY STAR Partner, Pitney Bowes has determined that the DM500™ and DM550™ Systems meets the ENERGY STAR guidelines for energy efficiency.

This system automatically enters a low power state called a “sleep mode” if you don’t use it for a while. This keeps energy consumption low, while maintaining the high state of readiness you expect from Pitney Bowes mailing equipment.

Pitney Bowes is committed to designing and manufacturing energy-efficient equipment because it lowers your operating costs and helps preserve the environment.

Office equipment is the fastest growing electricity load in the commercial buildings sector. The U.S. Environmental Protection Agency (EPA) promotes energy efficiency because electricity generation contributes to air pollution, including 35 percent of all U.S. emissions of carbon dioxide, one of the key contributors to global warming. It also accounts for 70 percent and 33 percent of all U.S. emissions of sulfur dioxides and nitrogen oxides, respectively; these contribute to acid rain and urban smog. By using more energy-efficient equipment, you can reduce both pollution and costs.

The ENERGY STAR program is another example of how Pitney Bowes is good for the environment and smart for business.

### Postage Meter

The postage meter on your mailing system is a Postal Security Device (PSD) that incorporates the latest technology approved by the United States Postal Service to secure funds. This technology eliminates the need to perform physical inspections thereby making the system easier and more convenient to use. The PSD contains the funds and performs all of the calculations necessary to print meter stamps that comply with the latest USPS standards.

## ***Easy-To-Use IntelliLink® Control Center***

The IntelliLink® Control Center is mounted on the top of your mailing machine and features a large easy-to-read graphic display, function keys and alpha and numeric keypads. A series of messages and options appear in the display to prompt you through all of the setup and mailing operations. You use the function keys and keypads to respond to the system prompts and select your options.

## ***Variety of Communications Options***

Your DM Series™ System comes with communications ports for data communications with Pitney Bowes support services and for interfacing to external devices such as a personal computer, an optional scale, or other peripherals.

An internal modem with an external interface to analog telephone lines allows data communications with Pitney Bowes support services as well as external mail/parcel carriers.

Communications with Pitney Bowes provides the following benefits:

- Postage By Phone® Meter Payment System refills
- Remote postage inspections
- Electronic Confirmation Services (Delivery Confirmation, Signature Confirmation, and electronic filing of Certified Mail)
- Ability to download graphic images (ads, inscriptions, and permits)
- Ability to download rate change and software updates

## ***Ability to Communicate with other Applications***

Your mailing machine has a peripheral communications USB port that allows you to connect to a personal computer (PC). Your system can communicate with the following software applications or application types running on a PC connected through the USB port:

- Data Exchange software
- AccuTrac™ Mail Accounting Software
- Ascent® Software
- Business Manager

### **Accounting and Reports**

#### **Standard Accounting and Reporting**

The standard accounting and reporting feature allows you to store postage costs for 25 accounts, or you can purchase options for storing 100 or 300 accounts. You can run reports on single or multiple accounts and limit access to the accounts by password protecting them. For more information on the standard accounting package, refer to *Chapter 7, Accounting* and *Chapter 8, Reports*, in this guide.

#### **Budget Manager**

You can also acquire the enhanced accounting package, Budget Manager. Budget Manager allows you to create more accounts with higher levels of detail.

For more information on Budget Manager, refer to *Budget Manager Operator Guide, SV60957*.

#### **Business Manager**

You can connect your DM Series™ system directly to a Business Manager host PC and control all of your accounts, operators and postal transaction data through the Business Manager Administration module. For more information on Business Manager, refer to the *Business Manager Operator Guide, SV61178*.

### **Advertisements and Inscriptions**

Ads and inscriptions are messages you can include in the meter stamp. A number of standard advertisements and inscriptions are included with your mailing system. You can order customized ads and inscriptions by calling the Pitney Bowes Supply Line™ (refer to the *Pitney Bowes Contact Information List* at the front of this guide for the phone number). For information on ordering ads and inscriptions, refer to *Chapter 11, Supplies and Options* in this guide.

When you order additional advertisements or inscriptions you receive an art card which you insert into a slot on the side of the IntelliLink® Control Center. Once installed, you can select an advertisement or inscription when you run mail.

### **Optional Permits**

You can print a permit on a piece of mail instead of a meter stamp. A permit is a postal mark containing a permit number that provides you with special processing or discount rates. You get the permit(s) from the US Post Office and the permit artwork from Pitney Bowes. For information on ordering permits, refer to *Chapter 11, Supplies and Options* in this guide.

## Parts of the Mailing System

This section describes the parts of your DM500™ and DM550™ System and includes:

- The Mailing System Exterior
- The Mailing System Interior
- The IntelliLink® Control Center
- The Main Screen

## Mailing System Exterior

**IntelliLink® Control Center** - This contains the screen and keypad for communicating with the mailing machine and the built-in postage meter (Postal Security Device).

**Feed and Main Covers** - Protect moving parts and prevent foreign objects from entering the machine. The feed cover protects the feeder and the main cover protects the transport area.

**Thickness Adjustment Knob** - You use this knob to adjust for the thicknesses of the envelopes you are feeding into your mailing system.

**Platform Scale** - You can acquire a 5 or 10 lb. integrated platform scale for your DM500™ or DM550™ System.

**On/Off switch** - Turns the mailing system on and off. This is located on the lower left side of the feed deck.

**Feed Deck** - This is where you load the mail.

**Side Guide** - Set this to reduce the skewing of pieces of mail as you feed them into the feeder.

**Transport Release Knob** - You pull this knob out to drop the lower half of the transport deck if you need to clear a jam.

**Art Card Slot** - The art card plugs into the art card slot on the right side of the IntelliLink® Control Center (as shown in the photo on the right). The art card contains advertisements and inscriptions.



**Quick Reference Card Set** - These are easy reference cards containing instructions for performing operations like how to set postage, process mail, or clear jams. The cards are located in a slot in the stacker module of your mailing system.

**Stacker** - This is where mail is deposited after the postage is applied to the piece of mail. It is located on the right side of the machine.

## 2 • Meet the DM500™ and DM550™ Digital Mailing System

---

### Mailing System Exterior continued

### The DM500™ and DM550™ System

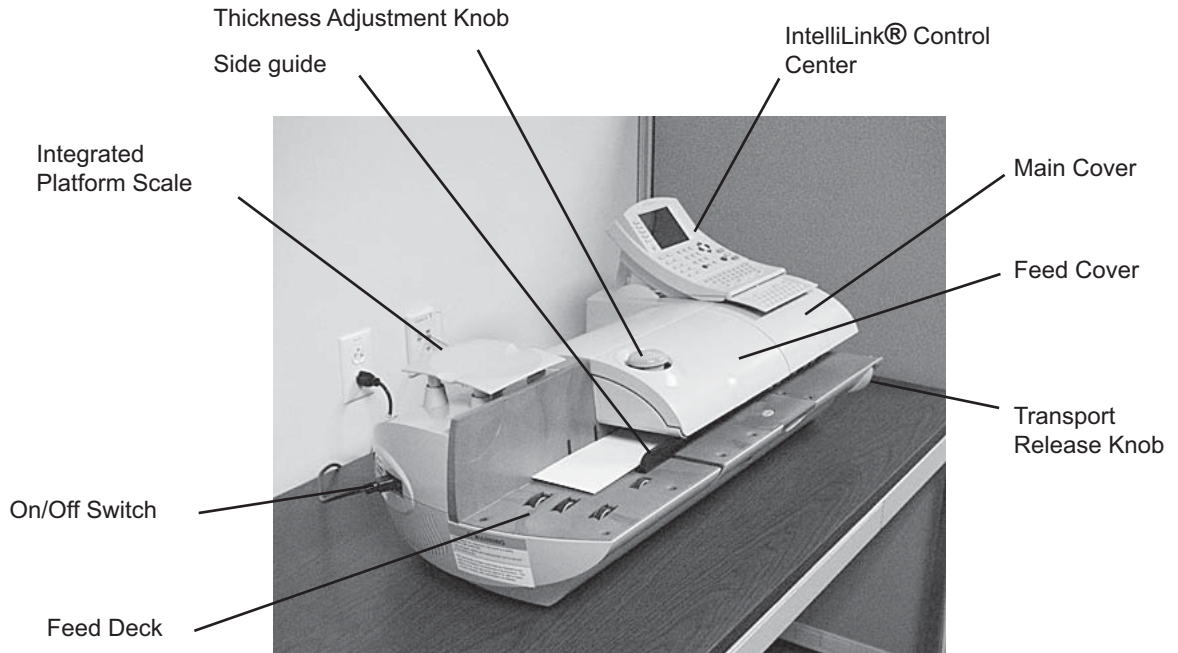

### Right Side View of the DM500™ and DM550™ System

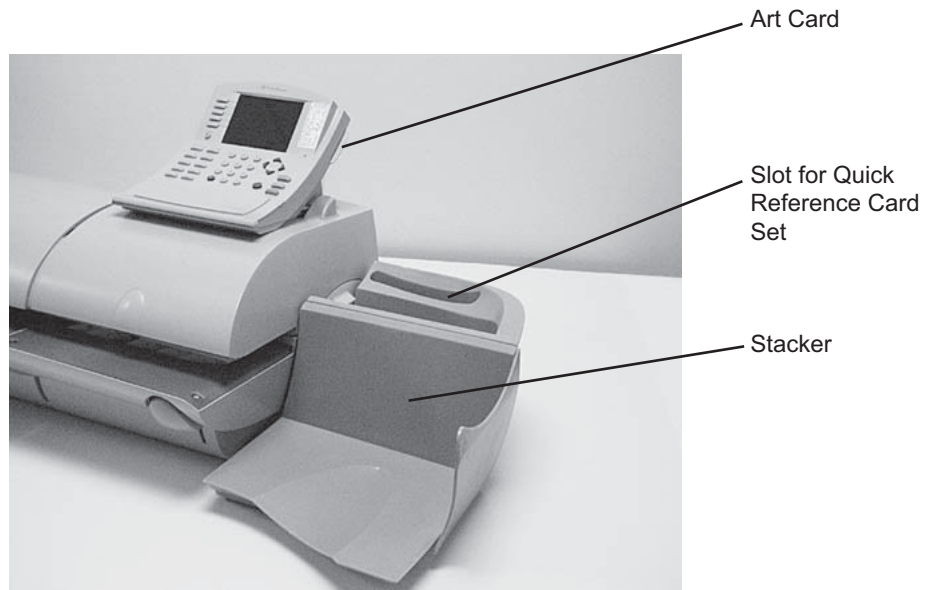



## Mailing System Exterior

continued

### Connectors on the Back of the Mailing System Base

**Dual External Device Ports** - Two USB ports are located on the back, lower right side of the machine. These provide communications with external USB devices such as a printer, an external scale, or a PC.

**Serial Port Connector** - One serial port connector. This is used for serial based applications like Budget Manager, PC Transfer, and Data Exchange.



### Mailing System

#### Exterior

continued

### Connectors on the Back of the IntelliLink® Control Center

**Internal Analog Phone Line Connector** - Depending on the version of your IntelliLink® Control Center, you may have an internal analog modem. The *Internal Analog Phone Line Connector* label in the figure below identifies the PCN numbers of the IntelliLink® Control Centers that have an internal analog modem and can connect directly to an analog phone line. The PCN number is located on the bottom of your IntelliLink® Control Center.

The term analog phone line refers to a RJ11C or RJ11W compatible (single line) telephone wall plug typically used for a residential phone or facsimile hookup.

**External (Modem) USB Connector** - The IntelliLink® Control Center has a connector for a USB device. If the PCN number of your IntelliLink® Control center is one of the ones listed under *USB Connector* label in the figure below, you must connect an external modem to this USB connector to dial into Pitney Bowes to perform feature updates or add postage. The PCN number is located on the bottom of your IntelliLink® Control Center.

**IntelliLink® Control Center AC Adapter Receptacle** - The receptacle for the AC adapter is located on the back of the IntelliLink® Control Center. If you need to remove the control center from the mailing system base and move it to an analog telephone line, you plug the AC adapter into this receptacle. When the control center is connected to the mailing system base, access to the AC adapter is blocked as indicated by the dotted line in the picture below.

Internal Analog Phone Line Connector

Use this to connect directly to an analog phone line if the PCN on the bottom of the IntelliLink® Control Center has the number: 1DXX



IntelliLink® Control Center installed on a DM Series™ System base. Dotted line indicates AC Adapter Receptacle is covered by base

USB Connector

Use this to connect an external modem if the PCN on the bottom of the IntelliLink® Control Center has the number: 1CXX

**Connecting  
the IntelliLink®  
Control Center to  
a Remote Phone  
Line**

This figure shows where you connect the AC adapter to the IntelliLink® Control Center after it has been removed from the mailing machine and moved to a remote analog phone line. For both internal and external modems, use the 26 AWG telephone cord included with the modem to connect to the phone line.

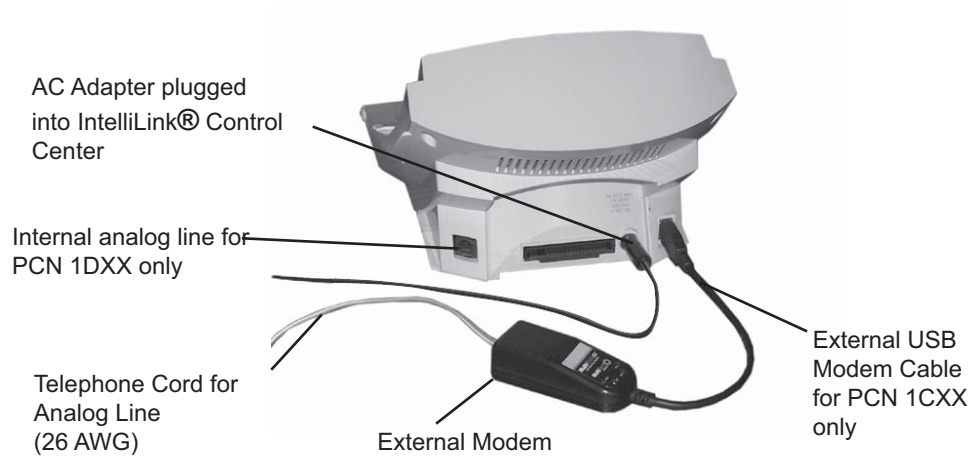

## 2 • Meet the DM500™ and DM550™ Digital Mailing System

### The Mailing System Interior

**Thickness Adjustment Knob** - Use this to adjust for the thicknesses of the envelopes. You do not have to lift the cover to adjust the knob.

For thicker pieces of mail (3/8" to 5/8"), or mail containing several inserts, use the thick mail setting. For mail containing only single inserts, or for postcards, use the normal mail setting. Refer to the figure on the right.

Thick mail setting



Normal mail setting

**Top Release Jam Lever/Lower Release Lever** - Lift these to clear jams on the Feed deck.

**Pressure-Sensitive Postage Tape** - Your mailing system uses this pressure sensitive tape to print reports and meter stamps for packages or pieces of mail that are outside the limits specified for mailing materials. See *Specifications, Mailing Materials* in *Appendix C* of this guide for details.

**Feed Deck** - This feeds the envelopes to the printer.

**E-Z Seal® Solution Bottle** - This contains the E-Z Seal® solution used for moistening and sealing envelopes.

Interior of DM500™ and DM550™ System  
(Under the Feed Cover)

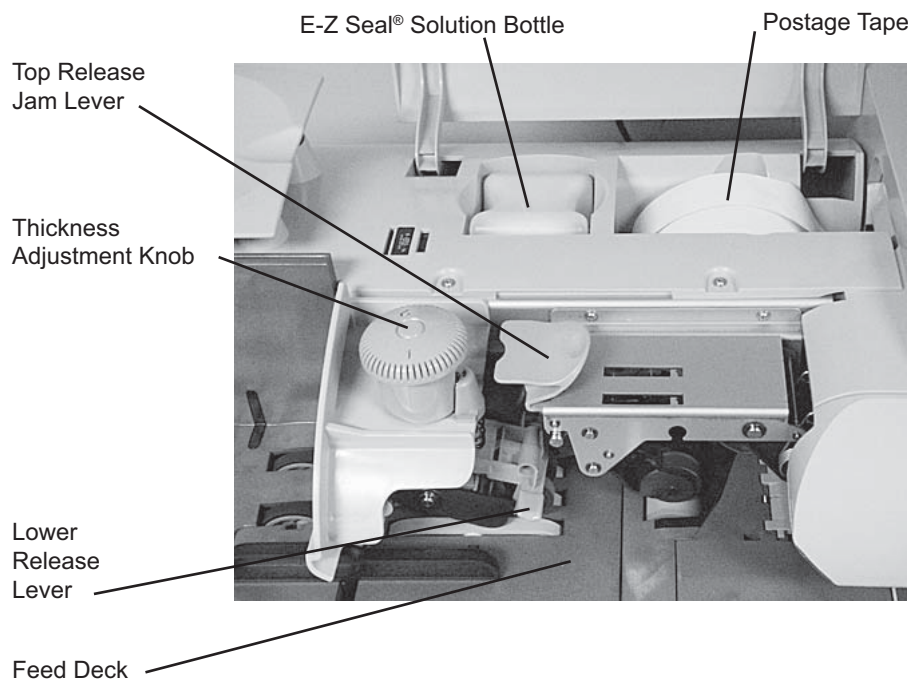

## **The Mailing System Interior**

continued

**Ink Cartridge** - This contains the ink used to create the meter stamp.

**Printhead** - This produces the meter stamp.

Interior of DM500™ and DM550™ System  
(Under the Main Cover)

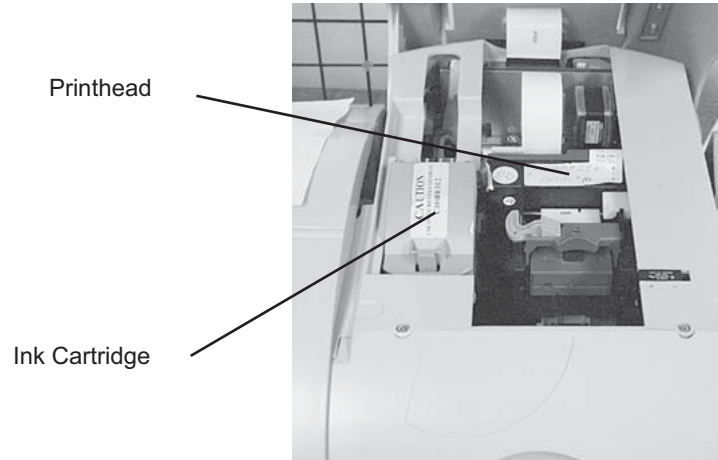

### The IntelliLink® Control Center

1. **Five Screen Keys** - The five keys directly to the left of the display screen allow you to select options displayed on the screen.
2. **Lock Button** - If no account is selected, this locks the IntelliLink® Control Center.
3. **Normal Preset Key** - Returns you to the most commonly used setting.
4. **Mode Key** - Press to choose from a variety of mail processing modes.
5. **Class Key** - Enables you to select the correct class for your mailing (e.g., First Class, Priority, Media mail).
6. **Seal Key** - Allows you to moisten and seal envelopes, with or without applying postage. You can also choose not to seal the envelopes at all.
7. **Accounts Key** - Press to set up and edit accounts.
8. **Custom Preset Key** - Use this to choose frequently-used system key settings for running different jobs.
9. **Menu Key** - Press to view the following settings and options:
  - Meter Stamp Options
  - Set Up
  - Zero Scale
  - Maintenance
  - Turn Features On
  - Confirmation Services
  - Adjust Display Contrast
10. **Funds Key** - Allows you to obtain the following information:
  - Funds Available (in postage meter))
  - Funds Used
  - Total Pieces (of mail processed by your mail system)
11. **Reports Key** - Offers a selection of different types of reports to run.
12. **Help Key** - Gives detailed information about a screen you are viewing.
13. **Numeric Keys** - Press numbered keys to enter postage amounts and weight. You can also use these keys to select numbered options appearing in the display.

## The IntelliLink® Control Center

continued

14. **Enter Key** - Press to enter the information you have selected for the mailing system.
15. **Arrow Keys** - Moves you to new menus, or scrolls menus and selects options.
16. **Start Key** - Begins processing mail with the options you have selected.
17. **Tape Key** - Allows you to print postage tapes for packages or pieces of mail that are outside the limits specified for mailing materials. See *Specifications* in *Appendix C* of this guide for details.
18. **Stop Key** - Ends a mail or tape processing job in progress.
19. **Clear Key** - Clears an entry, or takes you back one screen.
20. **Alpha Keyboard** - Use to enter accounts and other setup information. This keyboard is under a cover that opens for access.

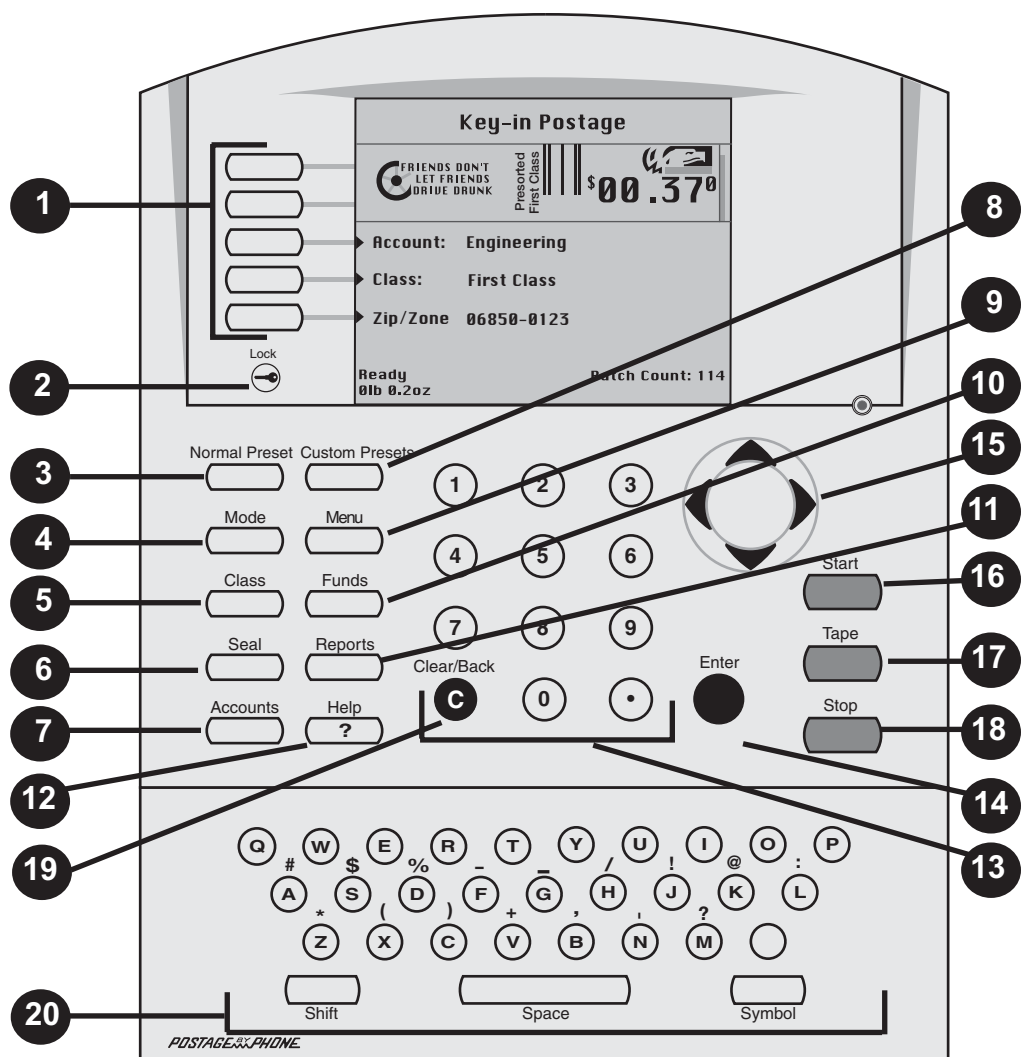

## The Main Screen

The content of the main screen depends upon the current mode of the machine. Main screens are the only screens that contain a meter stamp replica area and a main status area.

The main screen enters a sleep mode after a certain period of inactivity. Pressing any key wakes up the system and shows the last screen on the display, or the one corresponding to the Normal Preset settings (refer to *Define Presets* in *Chapter 5* in this guide for more information).

1. **Advertisement Display** - The optional message to be printed on the envelopes or tape (if selected).
2. **Account** - The optional account number or name charged with postage.
3. **Class** - The class you selected for the piece of mail.
4. **Main Status Area** - Important information such as warnings or help or navigation tips. For example, if you select a class, a message appears in this area.
5. **Weight Display Area** - The weight of the piece of mail.
6. **Mode** - The mode in which the piece of mail will be processed, or what the next required action will be.
7. **Meter Stamp** - The official USPS indicia printed on the envelope or tape.
8. **Batch Count** - The number of pieces of mail run in a job.

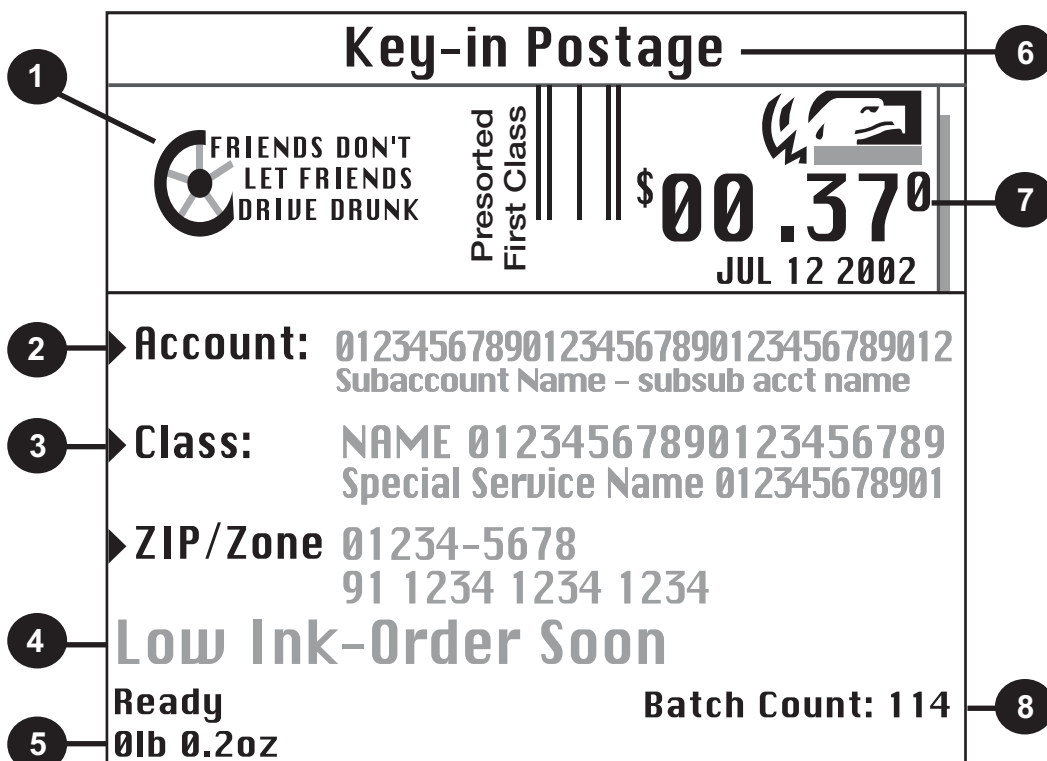



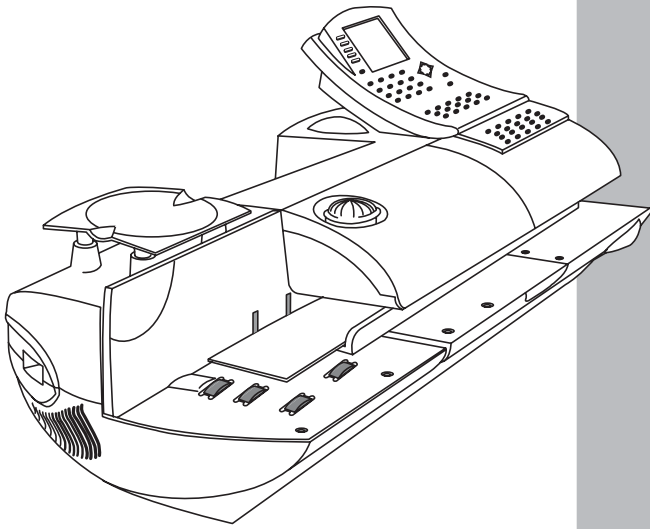

### 3 *Mail In A Minute*

#### *Contents*

<i>Mail In A Minute</i> .....	3-2
<i>Preparing Your Mail</i> .....	3-2
<i>Running the Mail</i> .....	3-3
<i>Printing Postage Tapes</i> .....	3-4

### Mail In A Minute

This chapter explains how to use the “Key In Postage” mode. It’s the quickest and easiest way to run a piece of mail or print a postage tape. Refer to the *Mailing Material* in the *Specifications* sections in *Appendix C* in this guide to make sure your mail is compatible with your mailing system.

---

Use this mode if:

- You know your postage amount
  - All envelopes are the same size
- 

For instructions on other available options for running your mail, see *Chapter 4, Running Mail* in this guide.

### Preparing Your Mail

1. Sort the mail by envelope size. If you are using the accounting feature, sort by account as well.

2. Place the stack of mail on the feed deck with the envelopes slanted slightly to the left (shingled) as shown in the picture at the right.

Place the envelopes with the flaps down and against the rear wall.

Slide the stack all the way forward to just inside the machine.

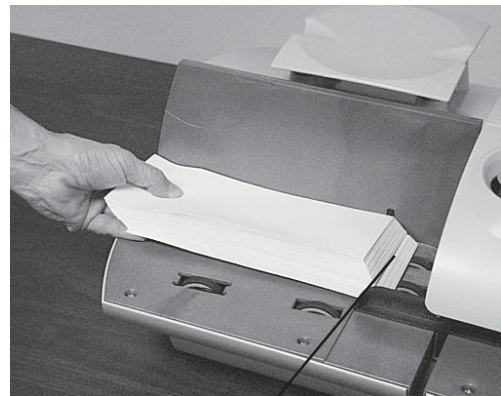

Envelopes shingled to the left

---

**NOTE 1:** Remove any onion skin/airmail type envelopes, Tyvek® envelopes, envelopes that are thicker than 5/8” or any pieces of mail that are outside the limits specified for mailing materials - see *Specifications, Materials* in *Appendix C* of this guide for details. Print the postage for this type of mail on tape.

**NOTE 2:** If you are using presealed envelopes, make sure you press the Seal key on the IntelliLink® Control Center and select **Sealer off** or the envelopes will jam.

**NOTE 3:** If you are running pieces of mail that are each 5/8” thick, you must run them one piece at a time. Do not stack them on the feed deck and attempt to feed them automatically - they will jam.

---

3. Adjust the side guide so it is close to, but not touching, the bottom edge of the envelope stack.

Be sure and leave a slight clearance between the side guide and envelopes (about 1/16 inch clearance).

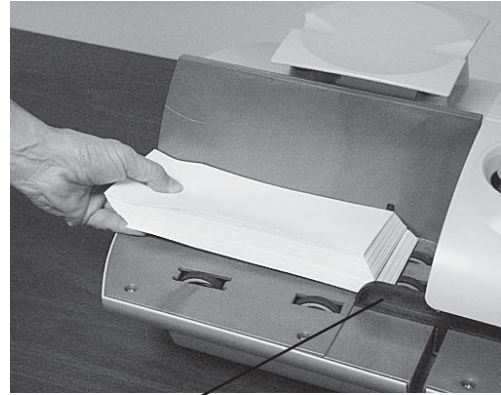

Side Guide

4. Adjust the thickness adjustment knob to adjust for envelope thickness. For thicker pieces of mail (3/8" to 5/8"), or mail containing several inserts, use the thick mail setting. For mail containing only single inserts, or for postcards, use the normal mail setting. Refer to the figure on the right.

To pick a setting, turn the knob to the arrow located on the feed cover.

5. Make sure you have sufficient funds in your postage meter. If the message "Low Funds" appears on the screen, make sure you can complete the mail run with the funds you have. If you do not have enough funds, see *Chapter 6, Adding Postage* in this guide.

Thick mail setting



Normal mail setting

## Running the Mail

1. Press the **Mode** key on the IntelliLink® Control Center.
2. Select **Key In Postage**.
3. Key in the correct postage value using the numeric keys on the control center, then press the **Enter** key.
4. Place the piece of mail on the feed deck and press the **Start** key.

### Printing Postage Tapes

Print postage tapes for:

- Packages
- Onion skin/airmail type envelopes
- Tyvek® envelopes
- Envelopes that are thicker than 5/8"
- Any pieces of mail that are outside the limits specified for mailing materials - see *Specifications, Mailing Materials* in *Appendix C* of this guide for details.

You can request up to 50 tapes at a time. The tapes exit into the stacker. The DM500™ and DM550™ Digital Mailing System is designed to use a special pressure sensitive adhesive tape made exclusively for it.



**WARNING!** Use only fresh rolls of Pitney Bowes tape to avoid distortion or jams in the mechanism and possible loss of postage.

---

To print a postage tape:

1. Locate the tape exit on the right side of the mailing system.
2. With the correct postage set on the main screen, press the **Tape** key to print one tape.
3. To print more than one tape, use the numeric keys to type in the number of tapes you want, then press the **Tape** key.

The system prints the tapes.

---

**NOTE:** Do not lift any of the covers on the mailing system while the tape is printing or the system will stop printing, cut and eject the tape.

---

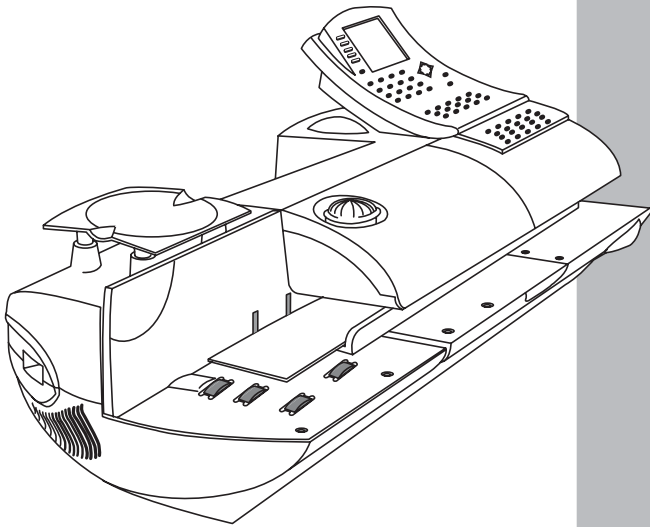

## 4 Running Mail

### Contents

<i>Navigating Hints</i> .....	4-2
<i>Applying Postage and Running Mail</i> .....	4-3
<i>Determining the Correct Postage Mode</i> .....	4-4
<i>Preparing Your Mail</i> .....	4-6
<i>Selecting the Postage Mode and Running Mail</i> .....	4-8
<i>Selecting or Deselecting an Account</i> .....	4-14
<i>Selecting the Class, Carrier, Special Services or Options</i> .....	4-15
<i>Selecting the Meter Stamp Options</i> .....	4-17
<i>Using Confirmation Services</i> .....	4-21
<i>Adding Postage or Changing the Date</i> .....	4-26
<i>Clearing the Batch Count</i> .....	4-28

### Navigating Hints

- The maximum number of options displayed is 5. To view more options, press the down arrow key.
- You can select a numbered option either by pressing the screen key next to the option, or by pressing the corresponding number on the keyboard and then pressing the **Enter** key.
- To go back one screen or more, clear an entry, or return to the “Ready” screen, press the **Clear** key. Pressing the left arrow key returns you to the main screen.
- Other selection or navigation or help information appears at the bottom of the screen. Also, check for messages next to the arrow keys on the bottom right side of the screen.

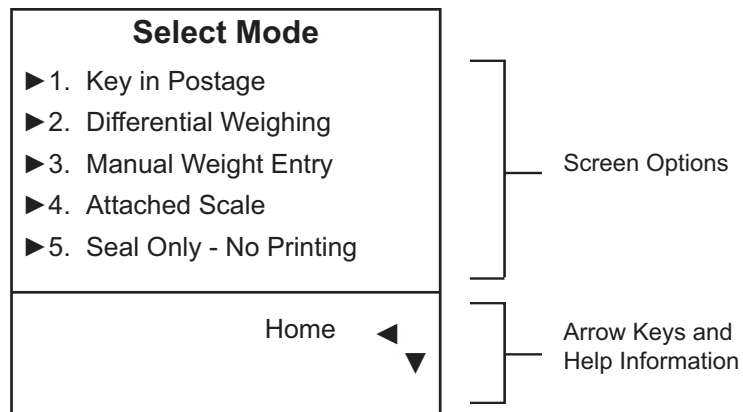

**Applying Postage and Running Mail**

To apply postage and run mail on the DM500™ and DM550™ System, follow the procedures listed here.

You must follow procedures 1 and 2 before you run mail through the system and apply postage. If you are using standard or enhanced accounting, you must also follow procedure 4.

Follow the other procedures listed here as needed.

For details on each procedure, refer to the section number listed here.

<b>1</b>	<b>Determining the Correct Postage Mode.</b> Deciding the appropriate mode for your specific mail run.
<b>2</b>	<b>Preparing Your Mail.</b>
<b>3</b>	<b>Selecting the Postage Mode and Running Mail.</b> Choosing the mode for running your mail and tapes.
<b>4</b>	<b>Selecting or Deselecting an Account to Print Postage.</b> Refer to this section if your system uses accounting.
<b>5</b>	<b>Selecting the Class.</b> Refer to this section if you need to specify a class or select a special service.
<b>6</b>	<b>Selecting Meter Stamp Options.</b> This section describes how to change the elements printed on your piece of mail.
<b>7</b>	<b>Using Electronic Confirmation Services.</b> This section tells you how to use preprinted barcode labels provided by Pitney Bowes to electronically process and submit records for USPS Confirmation Services to the Pitney Bowes Data Center.
<b>8</b>	<b>Adding Postage or Changing the Date.</b> This sections tells you how to add more postage or change the date of your postage.
<b>9</b>	<b>Clearing the Batch Count.</b> Refer to this section if you want to clear or reset the number of pieces of mail processed by your system.

### 1 Determining the Correct Postage Mode

#### Feeding Mail or Printing Tape?

1. If your mail requires no application of postage, see Chart C on the following page to choose your mode.
2. If your mail requires postage, you must determine if you can print directly on your mail.

You can feed mail if your pieces of mail are:

- under 5/8 in. (15.9 mm) thick.
  - over 3 in. x 5 in. or under 13 in. x 11 in.
  - under 5 lbs. or 10 lbs. depending on the capacity of the optional scale.
  - not too thin (such as fliers, or Tyvek® envelopes) or too fragile (such as air mail and onion skin envelopes) to pass through the feeder.
  - Meet the other requirements for mail feeding listed in *Specifications, Mailing Materials* in *Appendix C* in this guide.
3. If your mail meets the above requirements for feeding, select the appropriate mode from chart A below.
  4. If your mail does NOT meet the requirements for direct printing, you MUST print a postage tape. Select the applicable postage mode from chart B on the following page.

Chart A - Printing on Mail	
If:	then use this mode:
You know the amount of postage for your piece(s) of mail.	Key in Postage
You do not know the weight of your piece of mail.	Attached Scale
Your pieces of mail vary in types, sizes, and/or weights.	Differential Weighing (available only on the DM550™ Digital Mailing System)



**1 Determining the Correct Postage Mode**

continued

<b>Chart B - Postage Tape Mode</b>	
<b>If:</b>	<b>then use this mode:</b>
You know the amount of postage needed for your piece of mail.	Key In Postage
You do not know the weight of your piece of mail.	Attached Scale
You have several pieces of mail and do not know their postage	Attached Scale - AutoTape (An option you can purchase, not available on all systems.)
You know the weight.	Manual Weight Entry (An option you can purchase, not available on all systems.)
Your pieces of mail vary in types, sizes and/or weights.	Differential Weighing (available only on the DM550™ Digital Mailing System)

<b>Chart C - Mail Modes with NO Postage</b>	
<b>If:</b>	<b>then use this mode:</b>
Your mail requires a permit.	Print Permit (An option you may be able to purchase. Not available on all systems.)
You only want to seal the envelope and do NOT want to apply postage.	Seal Only (No Printing)
You want to print the date or time on incoming mail for record keeping.	Time and Date Stamp (An option you can purchase, not available on all systems.)

### 2 Preparing Your Mail

If you intend to run pieces of mail through your system, read *About Running Mail* below. If you are going to print postage tapes, read *About Printing Postage Tapes* on the following page.

Then, proceed to instructions for selecting the mode and running the job.

#### **About Running Mail**

Refer to *Specifications, Mailing Materials* in *Appendix C* in this guide to make sure your mail is compatible with your mailing system.

1. Sort mail by envelope size and, if you are using the accounting feature, sort by account.
2. Place the stack of mail on the feed deck with the envelopes slanted slightly to the left (shingled) as shown in the picture below. Place the envelopes with the flaps down and against the rear wall.

---

**NOTE 1:** If you are using pre sealed envelopes, make sure you press the Seal key on the IntelliLink® Control Center and select **Sealer off** or the envelopes will jam.

**NOTE 2:** If you are running pieces of mail that are each 5/8" thick, you must run them one piece at a time. Do not stack them on the feed deck and attempt to feed them automatically - they will jam.

---

3. Adjust the side guide so it is close to, but not touching, the bottom edge of the envelope stack.

Be sure and leave a slight clearance (about 1/16") between the side guide and envelopes.

Slide the stack all the way forward until it is just inside the machine.

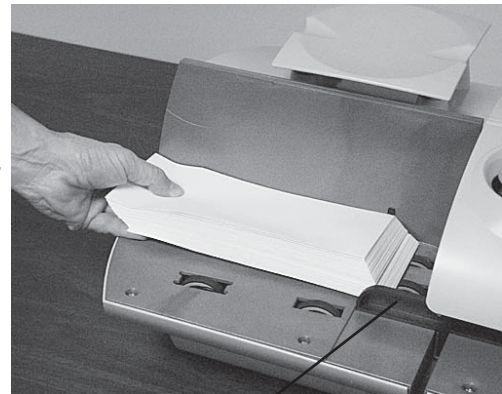

Side Guide

## About Running Mail

continued

- Adjust the thickness adjustment knob to adjust for envelope thickness. For thicker pieces of mail (3/8" to 5/8"), or mail containing several inserts, use the thick mail setting. For mail containing only single inserts, or for postcards, use the normal mail setting. Refer to the figure on the right. To pick a setting, turn the knob to the arrow located on the feed cover.

Thick mail setting



Normal mail setting

- If you are doing a large mail run, verify that you have sufficient funds in your postage meter. If you get the message "Low Funds" appearing in the display, make sure you can complete the mail run with the funds you have. If you do not have enough funds, see *Adding Postage* in *Chapter 6* in this guide.

## About Printing Postage Tapes

Print postage tapes for:

- Packages
- Onion skin/airmail type envelopes
- Tyvek® envelopes
- Envelopes that are thicker than 5/8"
- Any pieces of mail that are outside the limits specified for mailing materials - see *Appendix C, Specifications* in this guide for details.

You can request up to 50 tapes at a time. The tapes exit into the stacker. The DM500™ and DM550™ system is designed to use a special pressure sensitive adhesive tape made exclusively for it.



**WARNING!** Use only fresh rolls of Pitney Bowes tape to avoid distortion or jams in the mechanism and possible loss of postage.

- To print one tape, you simply press the **Tape** key instead of placing mail on the feed deck.
- To print more than one tape, use the numeric keys to type in the number of tapes you want, then press the **Tape** key. The tapes exit into the stacker on the right side of the mailing system.

---

**NOTE:** Do not lift any of the covers on the mailing system while the tape is printing or the system will stop printing, cut and eject the tape.

---

### 3 **Selecting the Postage Mode and Running the Mail**

Once you decide the appropriate mode for running your mail job, you select the mode on your mailing system. To access the modes, press the **Mode** key on the IntelliLink® Control Center.

The names of the modes as they appear on the screen are shown in the menu on the right.

Depending on your model number, you may have all or only some of these options.

For a detailed description of each mode, refer to the specific mode topic in this section. Follow the steps for your mode exactly.

#### Select Mode

- ▶ Key in Postage
- ▶ Differential Weighing
- ▶ Manual Weight Entry
- ▶ Attached Scale
- ▶ Attached Scale - AutoTape
- ▶ Print Permit
- ▶ Seal Only - No Printing

*\* International use only.*

#### **While your mailing system processes the mail, the screen:**

- Displays the status of the current job.
- Instructs you, if necessary:
  - to insert an envelope
  - to turn off the mailing machine
- Keeps a running count of processed mail.
- Displays errors, at which point the machine stops immediately.

### **Mode Selection: Key in Postage**

Use this mode if you know what the correct amount of postage is for your mail and you intend to apply this postage to each piece.

1. Press the **Mode** key.
2. Select **Key In Postage**.
3. Key in the correct postage value using the numeric keys on the IntelliLink® Control Center, then press the **Enter** key.

If you are done, place the mail on the feed deck and press the **Start** key, otherwise go to step 4.

4. If you want to change the date, add or change an advertisement or inscription, press the **Menu** key and select **Meter Stamp Options**.

For more information, refer to **6** *Selecting Meter Stamp Options* in this chapter.

5. When finished, place the stack of mail or piece of mail on the feed deck and press the **Start** key.

### **Mode Selection: Differential Weighing**

This option is available on your DM550™ Digital Mailing System if it has the optional integrated platform scale or an attached external scale.

This option allows you to place all of the mail on the scale at once, then remove each piece, one at a time and run it through the system. The system calculates the postage for each piece of mail you remove from the scale and applies the postage to the piece as it goes through the mailing system.

For larger pieces of mail (large envelopes or packages), you can use differential weighing to have the system automatically print a tape every time you remove a piece of mail from the scale.

#### **Before using differential weighing:**

- Make sure each piece of mail weighs at least as much as the amount specified as the differential trip weight during the installation of your mailing system. Refer to the *Set Up the Scale/Select Rates:Diff Weigh Trip Weight* section in *Chapter 5* in this guide.

#### **To use differential weighing:**

1. Remove all pieces of mail from the scale.
2. Set the scale to zero by pressing the **Menu** key, then selecting **Zero Scale**.
3. Press the **Mode** key.
4. Select **Differential Weighing**.
5. The system prompts you to place the mail on the scale.



**CAUTION:** Make sure you center the mail on the scale and check to be sure it is not touching any other surface or object.

---

6. Once you place the mail on the scale:
    - If you have previously selected a class, the system displays the following prompt at the top of the screen:  
Print tapes automatically    On or Off
      - a.) If you select On, then when you remove each piece of mail, the system automatically prints a tape.
      - b.) If you select Off, you remove the first piece of mail and place it on the feed deck. The system automatically feeds the mail.
    - If you have not previously selected a class, you are prompted to select one now. For more information, refer to **5** *Selecting a Class, Carrier or Special Service* in this chapter.
  7. Begin removing mail from the scale. Please note the following:
    - a.) Remove each piece of mail in a single continuous motion.
-

- b.) If you mistakenly remove more than one piece of mail, put all of the pieces of mail back on the scale. If you only put one piece back on, the system does not print the correct postage.
8. When you remove the last piece of mail from the scale, the system asks you if you want to print postage. This is in case the last piece you remove from the scale is the container for the mail.

## **Mode Selection: Manual Weight Entry**

To perform manual weight entry:

1. Press the **Mode** key.
2. Select **Manual Weight Entry**.
3. Type in the number of pounds and press **Enter**.  
If the weight of your mail is less than 1 lb, press the right arrow key to go to the ounces field.
4. Type in the number of ounces and press **Enter**.
5. Press the **Class** key if required and select the class. For more information, refer to **5** *Selecting a Class, Carrier or Special Service* in this chapter.

---

**NOTE:** If the weight you enter is invalid for the class, you are prompted to select another class.

---

6. If this is a package, press the **Tape** key, otherwise go to step 7.
7. Place the piece of mail on the feed deck.
8. Press the **Start** key.

## **Mode Selection: Attached Scale**

Use this option if the AutoScale feature is set to Off (see *Set Up Scales/Rates: AutoScale* in *Chapter 5* in this guide).

1. Press the **Mode** key.
2. Select **Attached Scale**. The “Attached Scale Mode” screen appears.
3. Place the piece of mail on the scale.



**CAUTION:** Make sure you center the mail on the scale and check to be sure it is not touching any other surface or object.

---

4. If the class displayed in this screen is incorrect, press the **Class** key and select the class. For more information, refer to **5** *Selecting a Class, Carrier or Special Service* in this chapter.
  5. If this is a package, press the **Tape** key, otherwise go to step 6.
  6. Place the piece of mail on the feed deck.
  7. Press the **Start** key.
-

### **Mode Selection: Attached Scale - AutoTape**

This feature may be offered as a standard or optional feature and is not available on all Pitney Bowes solutions. Please contact your local account representative to determine if this option is accessible on your system.

Use this option if you want the system to automatically weigh and print a tape as soon as you place a piece of mail on the scale.

Before using this weighing option:

- Make sure each piece of mail weights at least as much as the amount specified as the differential trip weight during the installation of your mailing system. For more information, refer to the *Set Up the Scale/ Select Rates:Diff Weigh Trip Weight* section in *Chapter 5* in this guide.
1. Set the scale to zero by pressing the **Menu** key, then selecting **Zero Scale**.
  2. Press the **Mode** key.
  3. Select **Attached Scale - AutoTape**.
  4. The “Print Tape Automatically” screen appears.
  5. Place each piece, one at a time on the scale.



**CAUTION:** Make sure you center the mail on the scale and check to be sure it is not touching any other surface or object.

**CAUTION:** Do not lean on or touch the scale since the system will interpret this as a piece of mail and will deduct postage.

---

The system prints a tape every time you place another piece of mail on the scale.

### **Mode Selection: Print Permit**

This feature may be offered as an optional feature and is not available on all Pitney Bowes solutions. Please contact your local account representative to determine if this option is accessible on your system.

Refer to *Ordering Permits for Your Mailing System* in *Chapter 11* in this guide for information on ordering permits.

A permit is a special postal mark used instead of the usual meter stamp imprint. You can file for a permit with the USPS. These permits provide you with special processing or discount rates.

Use permits when:

- You are processing standard mail.
- You want to apply prepaid postage to an enclosed reply envelope.
- You have a special rate agreement with the post office.



## To select a Print Permit:

1. From the IntelliLink® Control Center, press the **Mode** key.
2. Select **Print Permit**. The “Print Permit Selection” screen appears.
3. Select the permit you want and press **Enter**.
4. Place the mail on the feed deck.
5. Press the **Start** key.

## **Mode Selection:** **Seal Only**

Use this mode if you just want to seal the envelopes and do not want to apply postage.

1. Press the **Mode** key.
2. Select **Seal Menu - No Printing** and select the appropriate option.
3. Select the **Reset Counter** option if you want to clear the number of pieces of mail fed into the machine in the seal only mode.
4. Place the mail on the feed deck.
5. Press the **Start** key.

---

**NOTE:** For additional sealing options, press the **Seal** key on the IntelliLink Control Center. This allows you to select the following options:

---

- Sealer on (seal envelopes)
- Sealer off
- Seal only, don't print

### 4 Selecting or Deselecting an Account

The information here applies only if you are running the Standard Accounting package included with your DM Series™ system. If you are using Budget Manager or Business Manager refer to the operator guides provided with those applications.

If your system uses Standard Accounting, you must select an account.

#### **Select an Account**

1. Press the **Accounts** key and the system lists your accounts.
2. Use the down arrow to view more accounts if necessary.
3. Select the account you want to use to charge postage.

If the account is password protected, you are prompted to enter the password.

4. The system displays the main screen showing the account name/number as well as any subaccount or subsubaccount names.

For example, if you have a top-level account named “Engineering” with a subaccount named “Mechanical,” the following account name appears in the display:

Engineering  
    Mechanical

The lowest account name (in this case “Mechanical”) is the account that incurs the charges.

5. If this is a package, press the **Tape** key, otherwise go to step 6.
6. Place the piece of mail on the feed deck, set the thickness adjustment knob for the mail thickness and adjust the side guide for the width of the piece of mail.
7. Press the **Start** key

#### **Deselect an Account**

1. Press the **Accounts** key.
2. Select **0. None** from the top of the list.
3. “Account: None” now appears in the main screen.

**5 Selecting a Class, Carrier, or Special Service**

Each carrier has its own set of classes and each class has its own set of special services. When you select a class or carrier, only those options available for that selection display in the main screen.

---

**NOTE:** When selecting a class/carrier:

- If your system has been set up to retain the class on each piece of mail weighed then the class that appears in the main screen will be the one you selected last.
  - If you turn off and then turn on the power to your system, or if your system has been set up to clear the class on each piece of mail weighed, it will clear the class. In this case, you need to select a new class.
  - If you place a piece of mail on the scale, or enter a weight manually, the system automatically prompts you to select a new class if the new weight requires a different class.
- 

1. Press the **Class** key. A list of available classes appears in the screen.
2. Select the class and press **Enter**.
3. If a ZIP Code or Zone is required, you are prompted to enter it. Press **Enter** to accept it. For more information, refer to *Selecting a ZIP Code or Zone* in this section.
4. If a country is required, you are prompted to select it. Press **Enter** to accept. For more information, refer to *Selecting a Country* in this section.
5. If special services are available with the class you select, they are displayed.

Even if you do not want any special services, press the **Enter** key to confirm the class.

6. Press the **Tape** key to print a postage tape.

To apply postage to a piece of mail, place it on the feed deck and press the **Start** key.

### **Selecting ZIP Codes and Zones**

If your postal rate or special service requires a ZIP code or Zone, you are prompted to enter it. The system prompts you for either the ZIP Code or Zone (for details, see *Setting Up the Scale/Rates: ZIP/Zone prompt* section in *Chapter 5* of this guide).

1. When you select a class, you may be prompted to enter the ZIP Code or Zone.
2. To access the Intra-BMC Package Services Parcel Post rates, enter only the first 3 digits of the ZIP Code.  
To access the Inter-BMC Package Services Parcel Post rates, enter all 5 digits of the ZIP Code.
3. Press **Enter**.

### **Select a Country**

If your class requires you to select another country:

1. A list of countries appears in the display. You can scroll through the countries:
  - Using the up/down arrows
  - Typing in the first few letters of the country until you get a match
  - Typing in the numeric code for that country
2. Select the country you want.

**6** **Selecting the Meter Stamp Options**

The Meter Stamp Options selection allows you to change the elements printed on your piece of mail or tape. You access the Meter Stamp options by pressing the **Menu** key on the IntelliLink® Control Center and then selecting **Meter Stamp Options**.

The list of options that display depends on the model number of your mailing system. All of the possible options, shown in the menu on the right, are described in this section.

<b>Meter Stamp Options</b>	
▶	Date
▶	Ad/Messages
▶	Inscription
▶	Piece ID Number*
▶	Print Position
▶	Multiple Tapes
* <i>International use only.</i>	

**Meter Stamp Options:  
Date**

1. Press the **Menu** key.
2. Select **Meter Stamp Options**.
3. Select the **Date** option. Depending on your previous selections, a combination of the following selections appears.
  - Don't Print Date
  - Print only Month and Year
  - Advance Date (see NOTE)
4. Make your selection and follow the prompts on the main screen. Press **Enter** when complete.

---

**NOTE:** If you select **Advance Date** and choose to store it in a preset, refer to *How to Store Advance Date in a Custom Preset* in Chapter 5 in this guide.

---

### **Meter Stamp Options: Advertisement**

You can have a variety of advertisements appear on your mail. For a list of the advertisements provided with your mailing system, refer to *Chapter 11, Supplies and Options* in this guide.

To add more advertisements, refer to *Performing Updates or Adding Features* in *Chapter 9* in this guide.

1. Press the **Menu** key.
2. Select **Meter Stamp Options**.
3. Select the **AdMessage** option.
4. Use the down arrow key to scroll through the advertisements.
5. Press the screen key that is next to the advertisement you want. The advertisement then appears next to the meter stamp.

The advertisements provided with your system are shown here.

Address Service Requested  
Return Service Requested  
Seasons Greetings  
United States Flag

Recycle  
Happy Thanksgiving  
Please Open Immediately  
Urgent

ADDRESS SERVICE  
REQUESTED

RETURN SERVICE  
REQUESTED



**PLEASE OPEN  
IMMEDIATELY**

**URGENT**

## **Meter Stamp Options: Inscription**

You can have a variety of inscriptions appear on your piece of mail. For a list of the inscriptions provided with your mailing system, refer to *Chapter 11, Supplies and Options* in this guide.

To add more inscriptions, refer to *Performing Updates or Adding Features* in *Chapter 9* in this guide.

1. Press the **Menu** key.
2. Select **Meter Stamp Options**.
3. Select the **Inscription** option.
4. Use the down arrow key to scroll through the inscriptions.
5. Press the screen key that is next to the inscription you want. The inscription then appears next to the meter stamp.

The inscriptions provided with your system are shown here.

Presorted First Class  
Presorted Standard  
Non Profit Organization  
Standard  
Par Avion

Air Mail  
Printed Matter  
First Class  
Priority Mail  
Presorted

PRESORTED  
FIRST CLASS

PRESORTED  
STANDARD

NON PROFIT  
ORGANIZATION

STANDARD

PAR AVION

AIR MAIL

PRINTED  
MATTER

FIRST CLASS

PRIORITY MAIL

PRESORTED

### ***Meter Stamp Options: Print Position***

This selection allows you to move the print position of the meter stamp away from the right edge of the envelope.

1. Press the **Menu** key.
2. Select **Meter Stamp Options**.
3. Select the **Print Position** option.
4. Use the left and right arrow keys to switch between the possible positions (1 - 5 where 1 is the position closest to the right edge).

### ***Meter Stamp Options: Multiple Tapes***

This provides an alternate method for printing multiple tapes.

1. Press the **Menu** key.
2. Select **Meter Stamp Options**.
3. Select the **Multiple Tapes** option.
4. Enter the number of tapes you want to print.
5. Press **Enter**.



**7 Using Electronic Confirmation Services**

The United States Post Office (USPS) provides three types of confirmation services:

- **Delivery Confirmation** - shows you when the postal carrier delivered the mail.
- **Signature Confirmation** - shows you who signed for the mail.
- **Certified Mail** - provides you with proof that you mailed the item.

Each of these services has its own barcode labels. Using preprinted barcode labels provided by Pitney Bowes, you can electronically process and submit records for the three types of USPS Confirmation Services to the Pitney Bowes Data Center.

**Overview**

***Postage Calculation for Confirmation Services***

- As soon as you weigh your piece of mail and select the class and service, your mailing system automatically calculates the postage.

---

**NOTE:** When using these services, you cannot type in the postage manually. You can however use manual weight entry.

---

***Discounts for Confirmation Services***

- When you use any of these services with your mailing system and send the barcodes electronically over the phone line, you get a discount on the cost of the service.
- In some cases, like adding Electronic Delivery Confirmation to a Priority letter, you only pay the postage required for Priority mail.

---

**NOTE:** Your discounts are valid only if you use the barcode labels provided by Pitney Bowes and send the records electronically.

---

***Sending Your Records to Pitney Bowes***

- Your system stores up to 100 of your barcode records and automatically connects to Pitney Bowes and uploads these records either at the scheduled time you specified during set up, or whenever you have processed the maximum number of pieces of mail on the system.

---

**NOTE:** In order to automatically upload your records, your system must have a full-time dedicated analog phone line connection.

---

### Overview

continued

### **Tracking Information on the Internet**

- After 24 hours you can track your mail on the internet using your Pitney Bowes Postage By Phone® Meter Payment System account number and the barcode number. Go to the site:

*www.pb.com*

Click on **My Account** and go to the "Tracking and Mailing Tools" section.

- You can also track your mail by going to the Postal Service's web site at:

*www.usps.com*

### **Adding Services or Making Changes**

- If you already have postage on the mail and then decide you want to add a service, follow the instructions here for *Adding Confirmation Services After Printing Postage*.
- If you need to add more postage to cover the confirmation services, refer to the section, *Add Postage and/or Change the Date* in this chapter.
- If you realize you have put the wrong barcode on a piece of mail or package, you can change it as long as you have not sent the records to Pitney Bowes. Follow the instructions here for *Editing, Deleting or Sending Confirmation Services Records*.

## Using Confirmation Services Before Printing Postage

USPS Confirmation Services are available when you are in the Attached Scale mode, or Manual Weight Entry mode. Refer to *Select the Postage Mode* section in this chapter for more information.

The following procedure is based on using a Priority class and the E-Del Con service. Your procedure may vary slightly depending on your class and service.

1. Place the piece of mail or package on the scale.
2. Press the **Class** key.
3. Select the class, for example, **Priority**.
4. Select the service, for example, **E-Del Con**. As soon as you select the service, a check mark appears in front of it.
5. Press the **Enter** key.
6. At this point, you are prompted to enter the 5-digit destination ZIP Code. Use the numeric keyboard to enter the code.
7. Press the **Enter** key and the “Barcode” screen appears.
8. If this is the first time you are entering a confirmation service, the screen is blank and you need to enter the entire barcode value. If you have a barcode scanner, you can scan in the number.
  - a.) If you have used the confirmation service before, the next barcode value (in the series of barcode labels) appears, minus the last digit.
  - b.) If you have used all of the labels in a series of barcode labels, make sure you start with the top label with the lowest last 4-digits and not the bottom label with the highest last 4-digits. If you have a barcode scanner, you can scan in the number.
9. If you are using a barcode scanner and have set up your system to automatically enter the barcode value (see *Setting Auto-Enter* in *Chapter 5* in this guide), go to step 10.

If you type in the barcode value, enter the last digit of the number from the label you will use. Then press the **Enter** key to accept the barcode value and the system returns to the main screen (“Attached Scale Mode” appears).

---

**NOTE:** Make sure the barcode on the label matches the barcode value you just entered in the system.

---

10. Press the **Tape** key to print a tape. To print postage on a piece of mail, place it on the feeder and press the **Start** key.
11. You are prompted to apply the barcode label to the package. Apply the barcode to the package.
12. Press the **Enter** key. The “Enter another package?” screen appears. Follow the screen prompts to process more pieces of mail for confirmation services.

### **Adding Confirmation Services After Printing Postage**

If you have already applied postage to a piece of mail and you now want to add a confirmation service to it, follow the procedure here.

This procedure is based on using a **Priority** class and the **E-Del Con** service. Your procedure may vary slightly depending on your class and service.

1. Place the piece of mail or package on the scale.
2. Press the **Menu** key.
3. Press the down arrow key and then select **Confirmation Services**.
4. Select **Add Record**. The “Select Class” screen appears.
5. Select the class, for example **Priority Mail**. The “Select Service” screen appears.
6. Select the service, for example, **E-Del Con**. Press the **Enter** key.
7. At this point, you are prompted to enter the 5-digit destination ZIP Code. Use the numeric keyboard to enter the code.
8. Press the **Enter** key and the “Barcode” screen appears.
9. If this is the first time you are entering a confirmation service, the screen is blank and you need to enter the entire barcode value. If you have a barcode scanner, you can scan in the number.

If you have used the confirmation service before, the next barcode value (in the series of barcode labels) appears, minus the last digit.

If you have used all of the labels in a series of barcode labels, make sure you start with the top label with the lowest last 4-digits and not the bottom label with the highest last 4-digits. If you have a barcode scanner, you can scan in the number.

10. If you are using a barcode scanner and have set up your system to automatically enter the barcode value (see *Setting Auto-Enter* in *Chapter 5* in this guide), go to step 11.

If you type in the barcode value, enter the last digit of the number from the label you will use. Then press the **Enter** key. Once you have entered or accepted the displayed barcode value, you get a screen that summarizes the information you are sending.

---

**NOTE:** if you have selected a confirmation service that is not free, the postage amount appearing in the summary will be greater than the amount of postage you have already applied. If this is the case, you must add more postage after you have applied the barcode. Refer to the *Add Postage* section in this chapter.

---

11. Press the screen key for **OK** and the system stores the confirmation information. You are prompted to apply the barcode label to the package.
  12. Press the **Enter** key. The “Enter another package?” screen appears. Follow the screen prompts to process more pieces of mail for confirmation services.
-

**Editing, Deleting  
or Sending  
Confirmation  
Services  
Records**

This procedure tells you how to edit, delete or send confirmation services records once you have entered them into your system.

Your system can store up to 100 of your barcode records before sending them to Pitney Bowes.

1. Press the **Menu** key.
2. Press the down arrow key and then select **Confirmation Services**.
3. To edit an existing record, select **Edit records**. You can edit either the ZIP Code or barcode entry. To modify the class or service, you need to delete the record and add it as a new record.

To delete a record, select **Mark record for deletion** (you cannot delete a record once you have sent it to Pitney Bowes).

To send all of the confirmation service records now, select **Send records**.

4. As soon as the system sends all of your records, you can select to print a receipt on a tape or an envelope, or you can skip printing a receipt altogether.

### 8 Adding Postage or Changing the Date

If you do not have the correct postage or date on a piece of mail, you can add more postage or change the date directly on a piece of mail. If you prefer, you can print the corrections on a tape instead and then apply it to the piece of mail.

#### *To add more postage*

1. If you are printing more postage on an envelope and if the envelope is sealed, press the **Seal** key and select **Sealer Off**. If you are printing on a tape, go to step 3.
2. Turn the piece of mail around 180 degrees so that the meter stamp is in the lower left corner as shown here. Then, place the envelope on the feed deck with the flap facing down.

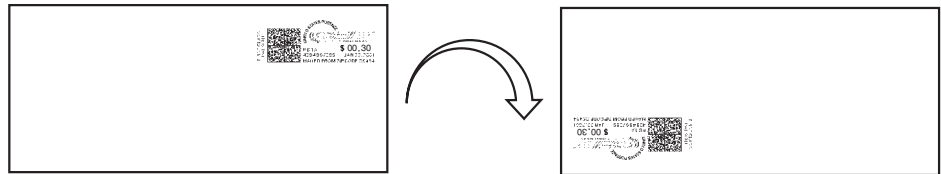

3. To add more postage, press the **Mode** key and select **Key In Postage**.
4. Enter the additional amount using the numeric keys and press **Enter**. Press the **Start** key.  
If you are printing a tape, press the **Tape** key.
5. The additional postage prints on the envelope as shown here.

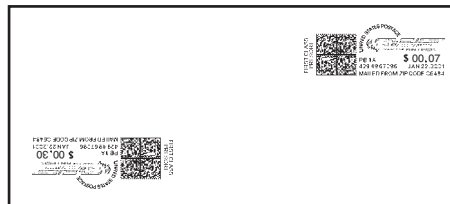

6. If you print a tape, apply the tape to the envelope below the existing meter stamp.

## To change the date

1. If you are printing the date correction on an envelope and if the envelope is sealed, press the **Seal** key and select **Sealer Off**. If you are printing on a tape, go to step 3.
2. Turn the piece of mail around 180 degrees so that the meter stamp is in the lower left corner as shown here. Then, place the envelope on the feed deck with the flap facing down.

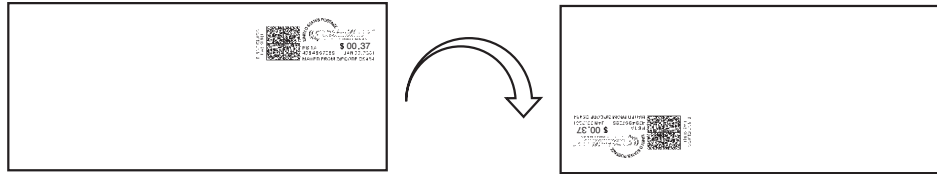

3. Press the **Mode** key and select **Key In Postage**.
4. Enter the 00.00 for the postage value using the numeric keys and press Enter.
5. Press the **Menu** key and then select **Meter Stamp Options**.
6. Select the **Date** option and make the appropriate selection.
7. Follow the prompts on the main screen. Press **Enter** when complete.
8. Press the **Start** key.

If you are printing a tape, press the **Tape** key.

9. The date correction prints on the envelope as shown here:

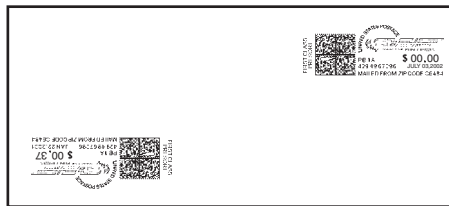

10. If you print a tape, apply the tape to the envelope below the existing meter stamp.

### 9 Clearing the Batch Count

If you keep track of the number of pieces of mail you process for each job or mail run, you may want to clear the batch count at the end of a run or just before starting a new run. The batch count appears on the display in the lower right corner.

To clear the batch count:

1. Press the **Funds** key.
2. The “View Funds” screen appears.
3. Press the right arrow key to clear the batch count.
4. If you have specified that a supervisor password must be entered to clear the batch count, you are prompted to enter the password now. Enter the password and press the **Enter** key.



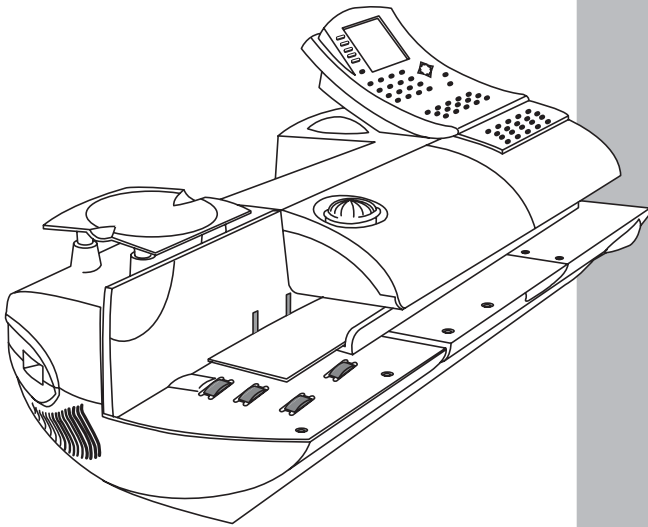

## 5 Mailing System Setup

### Contents

<i>Navigating Hints</i> .....	5-2
<i>Overview of Mailing System Setup</i> .....	5-3
<i>Setting the Display Language</i> .....	5-4
<i>Adjusting Display Contrast and Volume Control</i> .....	5-4
<i>Setting the Date and Time of Day</i> .....	5-5
<i>Setting Up A Supervisor Password</i> .....	5-6
<i>Setting A Lock Code</i> .....	5-7
<i>Setting Up the Scale/Selecting Rates</i> .....	5-8
<i>Setting Up Postage By Phone® Meter Payment System</i> .....	5-12
<i>Configuring High/Low Funds Warnings</i> .....	5-17
<i>Configuring Low Ink Warnings</i> .....	5-17
<i>Configuring System Timeouts</i> .....	5-18
<i>Defining Presets</i> .....	5-21
<i>Taking the Meter Out of Service</i> .....	5-25
<i>Adding an Optional Printer</i> .....	5-25
<i>Configuring the Optional Barcode Scanner</i> .....	5-26

### Navigating Hints

- The maximum number of options that display is 5. To view more options, press the down arrow key.
- You can select a numbered option either by pressing the screen key next to the option, or by pressing the corresponding number on the keyboard and pressing the **Enter** key.
- To go back one screen or more, clear an entry, or return to the “Ready” screen, press the **Clear** key. Pressing the left arrow key returns you to the main screen.
- Other selection or navigation or help information appears at the bottom of the screen. Also, check for messages next to the arrow keys on the bottom right side of the screen.

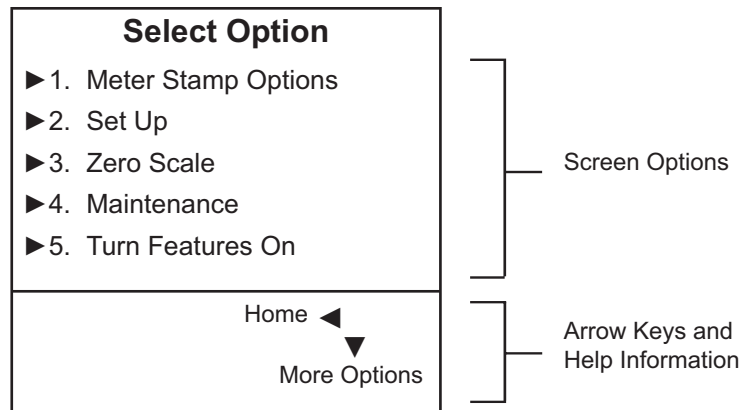

**Overview of Mailing System Setup**

If for any reason you need to change the original setup on your system, refer to the appropriate procedure(s) in the following list:

<b>1</b>	Setting the Language Display.
<b>2</b>	Adjusting the Display Contrast and Volume Control.
<b>3</b>	Setting the Date and Time of Day.
<b>4</b>	Setting up a Supervisor Password.
<b>5</b>	Setting up a Lock Code.
<b>6</b>	Setting up the Scale and Selecting Rates.
<b>7</b>	Setting up Postage By Phone®.
<b>8</b>	Configuring High and Low Funds Warnings.
<b>9</b>	Configuring Low Ink Warnings.
<b>10</b>	Configuring System Timeouts.
<b>11</b>	Defining Presets.
<b>12</b>	Taking the Meter Out of Service.
<b>13</b>	Setting up the Optional Printer.
<b>14</b>	Configuring the Optional Barcode Scanner.

### 1 Setting the Display Language

Depending on the model of your mailing system, you may be able to set the display to any of the following languages:

- English
- Espanol
- Francais

To change the language of the display:

1. Press the **Menu** key.
2. Select **Set Up**.
3. Select **Change Language**.
4. Select the language you want to appear in the display.
5. Press the **Enter** key.

### 2 Adjusting Display Contrast and Volume Control

You can adjust the contrast of your display and set the volume (1D00 only) of the speaker on your mailing system.

To adjust the contrast level of your display:

1. Press the **Menu** Key.
2. Press the down arrow key and then select **Adjust Display Contrast**.
3. Use the left or right arrow keys on the control center to select the contrast (1 - 9) you want. The screen updates to the new setting.
4. Press the **Enter** key to save this setting.

To adjust the volume (1D00 only):

1. Press the **Menu** Key.
2. Press the down arrow key and then select **Volume Control**.
3. Select the volume level you want (0 = off, 1 = low, 2 = medium, 3 = high).
4. Press the **Enter** key.

## 3 Setting the Date and Time of Day

If your mail is picked up at a certain time each day, you can set your system to advance the date at the mail pickup time.

---

**NOTE:** The date on the meter stamp should correspond to the date when your mail goes to the post office.

---

If you enter an invalid time or date, the system beeps and the screen displays the message: "Invalid Time".

To adjust the time and enter date advance:

1. Press the **Menu** key.
2. Select **Set Up**.
3. Press the down arrow and select **Time of Day**.
4. You can select:

**Current Time**

**Date will Advance After**

**Daylight Saving**

5. For **Current Time** or **Date will Advance After**, enter the correct time. Use the right arrow key to toggle between AM and PM. You do not need to enter the colon (:) between hours and minutes.

For **Date will Advance After**, as soon as your system reaches the time you set, it automatically advances the date 24 hours and prints that date on your postage.

Press **Enter** to accept the time. To return to the main screen, press the left arrow key.

6. Select **Daylight Savings** to turn the Daylight Saving mode on or off. Select **Turn off**, or **Turn on**.

To exit the Daylight Saving mode, press the left arrow key.

### 4 Setting Up a Supervisor Password

You can limit access to the following operations by creating a supervisor password.

- Adding Postage (Refill)
- Clearing Batch Information (the number of pieces of mail your system processes)
- Setting up Scale/Rates
- Accounting Setup

Whenever you perform any of these operations, the system prompts you for the password.

#### ***To create a supervisor password:***

1. Press the **Menu** key.
2. Select **Set Up**, then select **Basic Settings**.
3. Select **Supervisor Set Up**. Enter the current password if prompted.
4. Select **Edit (or Add) Supervisor Password** to create or change an existing password. The system prompts you to enter the password and then confirm it.

---

**NOTE:** Passwords are case-sensitive and must be at least 4 characters or digits long.

---

#### ***To password protect an operation:***

1. Press the **Menu** key.
2. Select **Set Up**, then select **Basic Settings**.
3. Press the down arrow and select **Supervisor Set Up**.
4. Select the option that corresponds to the operation you want to password protect. The options are:
  - a.) **Refill** - select this to require a password for adding postage.
  - b.) **Clear Batch** - select this to require a password before you can clear the batch count information from the system. The batch count corresponds to the number of pieces of mail processed by the system.
  - c.) **Scale/Rates Setup** - select this to require a password before you can modify any of the Scale/Rates features.
  - d.) **Accounting Setup** - select this to password protect account editing and setup.

**5** **Setting  
Up a Lock  
Code**

Use the Lock Code option to enter a four- digit password to prevent unauthorized use of your postage meter.

1. Press the **Menu** key.
2. Select **Set Up**, then select **Basic Settings**.
3. Select **Lock Code** and two options are displayed:

a.) **Lock Code - On/Off**

b.) **Change Lock Code**

If this is the first time you are setting up a lock code, “Off” appears next to the **Lock Code** selection.

4. Select **Lock Code** and enter a four digit code. Press **Enter** and the system prompts you to confirm it.

As soon as you confirm the code, “On” appears next to the **Lock Code** selection.

5. Press the **Clear** key or the left arrow to exit and set the lock code.
6. To activate the system lock, press the **Lock** button on the IntelliLink® Control Center.

### 6 Setting Up the Scale and Selecting Rates

If you have a scale on your DM500™ or DM550™ Digital Mailing System, you can use this section to set up how your scale works with your system.

For example, the **Attached Scale** option allows you to set your scale to accommodate for environments subject to vibrations.

The **Class if new Piece**, **Dest. if new Piece** and **Dest. if new Class** options allow you to specify if you want to clear or retain the class or destination (ZIP Code or Zone) whenever you put a new piece of mail on the scale.

The list of options that displays depends on the model number of your mailing system. All of the options are listed in the menu on the right.

Scale/Rates Setup	
▶	Attached Scale
▶	Autoscale
▶	Diff Weigh Trip Wt
▶	Class if new Piece
▶	Dest. if new Piece
▶	Dest. if new Class
▶	ZIP/Zone Prompt
▶	BMC Intra ZIP
▶	Add ZIPs to Zone 0
▶	Discount Code
▶	Confirm Svc

1. To access the scale/rates options, press the **Menu** key on the IntelliLink® Control Center and select **Set Up** from the main screen. Press the down arrow key and select **Scale/Rates**.
2. If you have set up a supervisor password for Scale/Rates, you are prompted to enter the password.

#### **Scale/Rates: Attached Scale**

This option appears only if you have an integrated scale or an attached external scale connected to your mailing system. Use this option to select how much time your system allows the scale to settle (Normal or Adjust for Motion).

Select Adjust for motion if your mailing system is in an environment subject to vibrations, such as near air-conditioning vents or closing doors. If you select this, the scale will require more time to settle.

---

**NOTE:** If this is the first time you are using an attached scale, you may be prompted to enter a location code. Contact the Pitney Bowes Help Desk. Refer to the *Pitney Bowes Contact Information List* at the front of this guide for the phone number.

---

1. Press the **Menu** key on the control center and select **Set Up**. Press the down arrow key and select **Scale/Rates**.
2. Select **Attached Scale**. The “Vibration Setting” screen displays.
3. Press the screen key for the Attached Scale selection in this screen to toggle between **Normal** and **Adjust for Motion**.
4. Press the **Enter** key to accept.



## **Scale/Rates: AutoScale**

You can set AutoScale to On or Off.

Select **On** to enable the AutoScale feature.

Select **Off** to disable this feature.

If you disable this feature and your system has an attached scale, you need to select the Attached Scale mode when running mail if you want your system to weight the mail and calculate postage. Refer to the *Selecting the Postage Mode and Running Mail* section in *Chapter 4* in this guide.

1. Press the **Menu** key on the control center and select **Set Up**. Press the down arrow key and select **Scale/Rates**.
2. Press the screen key for the **AutoScale** selection to toggle between On and Off.
3. Press **Clear** or press the left arrow to exit.

## **Scale/Rates: Diff Weigh Trip Weight**

Use this option to set the minimum weight that a piece of mail must weigh in order to use the differential weighing mode to print postage on a tape or on a piece of mail. For more information on differential weighing, refer to the *Selecting the Postage Mode and Running Mail* section in *Chapter 4* in this guide.

When your system is shipped, the trip weight is set to 0.5 ounces (10 grams). It is best to set the trip weight as high as possible to match the lowest weight that you will use. For example, a #10 envelope with a single insert typically weighs 0.4 ounces. In this case, you would set the trip weight to 0.4 ounces. This will improve the efficiency of your system, especially in the AutoTape mode.

1. Press the **Menu** key on the control center and select **Set Up**. Press the down arrow key and select **Scale/Rates**.
2. Select the **Diff Weigh Trip Wt** option and use the numeric keypad to enter the trip weight.
3. Press the **Enter** key to set the weight.

## **Scale/Rates: Class if New Piece**

Use this option to set the system to clear the class for each piece of mail weighed or to keep the last class used.

1. Press the **Menu** key on the control center and select **Set Up**. Press the down arrow key and select **Scale/Rates**.
2. Select **Class if new Piece**.
  - To clear the class information select **Clear; set class to none**.
  - To retain the class information select **Retain; use previous class**.
3. The system returns to the Scale/Rates Set Up menu.

## 5 • Mailing System Setup

---

### **Scale/Rates: Destination if New Piece**

Use this option to set the system to clear the destination ZIP or Zone code for each piece of mail weighed, or to keep the last class used.

1. Press the **Menu** key on the control center and select **Set Up**. Press the down arrow key and select **Scale/Rates**.
2. Select **Dest. if new Piece**.
  - To clear the destination select **Clear; set class to none**.
  - To retain the destination select **Retain; use class destination**.
3. The system returns to the Scale/Rates Set Up menu.

### **Scale/Rates: Destination if New Class**

Use this option to set the system to clear the destination ZIP or Zone code each time you change the class of mail, or to keep the last destination ZIP or Zone code used.

1. Press the **Menu** key on the control center and select **Set Up**. Press the down arrow key and select **Scale/Rates**.
2. Select **Dest. if new Class**.
  - To clear the destination select **Clear; set destination to none**.
  - To retain the destination select **Retain; use previous destination**.
3. The system returns to the Scale/Rates Set Up menu.

### **Scale/Rates: ZIP/Zone Prompt**

This feature may be offered as a standard or optional feature and is not available on all Pitney Bowes solutions. Please contact your local account representative to determine if this option is accessible on your system.

If the class and weight of your mail requires you to provide a destination ZIP or Zone code, select this option to enter a ZIP or Zone code.

1. Press the **Menu** key on the control center and select **Set Up**. Press the down arrow key and select **Scale/Rates**.
2. Select **ZIP/Zone Prompt**.
3. If you prefer to enter ZIP codes all the time when you are running mail, select **ZIP Code**.  
If you prefer to enter Zones all the time when you are running mail, select **Zone**.
4. If you use both ZIP and Zones when running mail, select **Prompt**.

## **Scale/Rates: BMC Intra ZIP**

Use this option to edit a group of predefined zip code ranges, or create a new group of ZIP Codes, within a Bulk Mailing Center (BMC).

1. Press the **Menu** key on the control center and select **Set Up**. Press the down arrow key and select **Scale/Rates**.
2. Select **BMC Intra ZIP**.
3. To create a new group, select **Create new group** and enter the new beginning and ending ZIP Code. You only need to enter the first three digits of the beginning and ending ZIP code.
4. To edit an existing group press the corresponding screen key for that group. You are prompted to enter a new beginning and ending ZIP Code. You only need to enter the first three digits of the beginning and ending ZIP code.

## **Scale/Rates: Add ZIPs to Zone 0**

This feature may be offered as a standard or optional feature and is not available on all Pitney Bowes solutions. Please contact your local account representative to determine if this option is accessible on your system.

Use this option to take advantage of local zone rates for one or more ZIP codes. When you select this option, you can add a new ZIP Code to the zone 0 rate, delete all ZIP Codes from the zone 0 rate, or edit an existing ZIP Code in the zone 0 rate.

1. Press the **Menu** key on the control center and select **Set Up**. Press the down arrow key and select **Scale/Rates**.
2. Select **Add ZIPs to Zone 0**.
3. Select the option you want .
4. To add a new ZIP or edit an existing one, use the numeric keys to enter all 5 digits of the new or edited ZIP Code.
5. Press **Enter** when complete.

## **Scale/Rates: Discount Code**

This feature may be offered as a standard or optional feature and is not available on all Pitney Bowes solutions. Please contact your local account representative to determine if this option is accessible on your system.

This is for international use. Use this option to apply discounts and/or surcharges to a different carriers and classes.

1. Press the **Menu** key on the control center and select **Set Up**. Press the down arrow key and select **Scale/Rates**.
2. Select **Discount Code**.
3. Select **Create new** to create a new discount code,  
Select one of the displayed carrier names to edit an existing discount code.
4. Define or edit the carrier, class, sub and subclass, and whether you are applying a discount or surcharge at a percentage or flat rate.
5. Follow the system prompts.

### **Scale/Rates: Confirm Svc Barcode Prompt**

This feature may be offered as a standard or optional feature and is not available on all Pitney Bowes solutions. Please contact your local account representative to determine if this option is accessible on your system.

When using USPS Confirmation Services, you can turn this option on to have the system display the following prompt when it is time to apply a barcode:

“Apply barcode label to package”

1. Press the **Menu** key on the control center and select **Set Up**. Press the down arrow key and select **Scale/Rates**.
2. Select **Confirm Svc Barcode Prompt** to toggle between on and off.
3. Press **Clear** or the left arrow to exit.

## **7 Setting Up Postage By Phone® Meter Payment System**

This section describes how to set up Postage By Phone® Meter Payment System on your mailing system. It also includes advanced phone setup instructions for modifying individual phone connection parameters (user ID and password and server IP address).

To access the Postage By Phone® System setup options, press the **Menu** key on the IntelliLink® Control Center, select **Set Up** from the main screen, and then select **Phone/Network Set Up**.

All of the possible options are listed on the menu at the right.

### **Phone/Network Set Up**

- ▶ PBP Account #
- ▶ Dialing Prefix
- ▶ PB Phone #
- ▶ Secondary PB #
- ▶ My Phone #
- ▶ Dialing Type
- ▶ Modem Type
- ▶ Modem String
- ▶ Network Settings

## **Phone/Network Set Up: PBP Account #**

Your Pitney Bowes representative uses this to set up your Postage By Phone® Meter Payment System account when installing your mailing system. Your account number is supplied by Pitney Bowes when you order your system.

Do not change this unless you are directed to do so by Pitney Bowes.

## **Phone/Network Set Up: Dialing Prefix**

If you need to dial a number in order to reach an outside line, use this option to enter that prefix number.

1. Press the **Menu** key on the control center. Select **Set Up** from the main screen, then select **Phone/Network Set Up**.
2. Select **Dialing Prefix**.
3. Use the numeric keypad to enter the number you need to dial to reach an outside line, for example, 9.  
To enter a symbol hold down the **Symbol** key and at the same time press the key for the symbol (for example, the # or \* keys).
4. Press the **Enter** key.

## **Phone/Network Set Up: PB Phone #**

Use this option to enter the Pitney Bowes phone number that you use to add postage to your postage meter.

1. Press the **Menu** key on the control center. Select **Set Up** from the main screen, then select **Phone/Network Set Up**.
2. Select **PB Phone #**. This number is supplied by your Pitney Bowes representative.
3. Use the numeric keypad to enter the phone number you need to dial to connect to Pitney Bowes to add postage, or select **Reset to Factory Phone Number** to change back to the number present when the system was delivered.
4. Press the **Enter** key.

## 5 • Mailing System Setup

---

### **Phone/Network Set Up: Secondary PB #**

This feature may be offered as a standard or optional feature and is not available on all Pitney Bowes solutions. Please contact your local account representative to determine if this option is accessible on your system.

Use this option to enter a secondary or alternative Pitney Bowes phone number to dial if the first or primary number is busy.

1. Press the **Menu** key on the control center. Select **Set Up** from the main screen, then select **Phone/Network Set Up**.
2. Select **Secondary PB #. This number is supplied by your Pitney Bowes representative.**
3. Use the numeric keypad to enter the phone number you need to dial to perform add postage.
4. Press the **Enter** key.

### **Phone/Network Set Up: My Phone #**

Use this option to enter your local phone number (the number to which you mailing system is connected).

1. Press the **Menu** key on the control center. Select **Set Up** from the main screen, then select **Phone/Network Set Up**.
2. Select **My Phone #.**
3. Use the numeric keypad to enter your local phone number. Be sure and include the area code with your number.  
Also, use only digits and do not include spaces or dashes.
4. Press the **Enter** key.

### **Phone/Network Set Up: Dialing Type**

This feature may be offered as a standard or optional feature and is not available on all Pitney Bowes solutions. Please contact your local account representative to determine if this option is accessible on your system.

Use this option to set the modem to tone or pulse dialing.

1. Press the **Menu** key on the control center. Select **Set Up** from the main screen, then select **Phone/Network Set Up**.
2. Select **Dialing Type**.
3. Use the right arrow key to toggle between tone or pulse dialing.
4. Press the **Clear** key or the left arrow to exit.

## **Phone/Network Set Up: Modem Type**

Use this option allows you to select the modem type: USB, Serial, or Internal. Once you select the type, the Phone/Network Set Up screen reappears.

1. Press the **Menu** key on the control center. Select **Set Up** from the main screen, then select **Phone/Network Set Up**.
2. Select **Modem Type** and the "Select Modem Type" screen appears.
3. Select the appropriate modem type (USB or Serial). The Phone/Network Set Up screen reappears.
4. In order for this change to take effect you must restart your system. Use the On/Off switch located on the base of your machine to restart your system (see *Mailing System Exterior* section in *Chapter 2* of this guide for the location of the On/Off switch).

## **Phone/Network Set Up: Modem String**

The modem string is a series of numbers and letters that the modem transmits when it calls Pitney Bowes. This string is entered by your Pitney Bowes customer service representative.



**CAUTION:** If you enter this screen, do not press the **Clear** key or you will clear the modem string entered by your Pitney Bowes representative.

---

To keep the same number, press **Enter**.

### **Phone/Network Set Up: Network Settings**

This option allows you to modify individual phone connection parameters.



**CAUTION:** Changing these parameters may result in errors when trying to contact Pitney Bowes. Contact your Pitney Bowes representative or call the Help Desk if you are not sure. Refer to the *Pitney Bowes Contact Information List* at the front of this guide for the phone number.

---

1. Press the **Menu** key on the control center. Select **Set Up** from the main screen, then select **Phone/Network Set Up**.
2. Select **Network Settings**. The "Network Set Up" screen appears and displays the following options:
  - Distributor Parameters
  - Mailing System Network Settings
3. If you select **Distributor Parameters**, the system displays the following connection parameters:
  - Global Account & User Id
  - Global Password
  - ANI/LCZ Server IP
  - ANI/LCZ Server Port #
  - Primary DNS Server
  - Secondary DNS Server
  - Distributor URL
  - Backup Data Center URL
4. If you select **Mailing System Network Settings**, the system displays the following options.
  - Get IP Address
  - IP Address
  - Subnet Mask
  - Default Gateway
  - MAC Address (you cannot modify this)
5. Select the parameter you want to edit and make the changes.
6. Press **Enter** when complete.



## 8 Configuring High/Low Funds Warnings

### **Setting the Low Funds Warning Value**

Use this option to set a value at which the mailing system warns you that the funds remaining in the meter are getting low.

1. Press the **Menu** key on the control center, select **Set Up** from the main screen, and then select **Basic Settings**.
2. Select **Low Funds Warning**.
3. Enter the low value warning amount using the numeric keyboard.
4. Press the **Enter** key.

### **Setting the High Value Warning for Key In Postage**

Use this option to set a value at which the mailing system warns you that you have entered a postage value that is more than the amount you are setting here. This feature prevents you from accidentally printing a postage amount that is more than you need.

1. Press the **Menu** key on the control center, select **Set Up** from the main screen, and then select **Basic Settings**.
2. Select **High Value Warning**.
3. Enter the high value warning amount (\$0 - \$99.99) using the numeric keypad.
4. Press the **Enter** key.
5. Confirm that the high value warning amount that appears in the displayed is correct. Press the key corresponding to the option you want.

## 9 Configuring Low Ink Warning

Use this option to specify how you want the system to notify you when you are running low on ink.

### **1st Low Ink Warning:**

1. Press the **Menu** key on the control center, and select **Set Up**.
2. Select **Basic Settings**.
3. Press the down arrow key and select **1st Low Ink Warning**
4. Press the screen key corresponding to the option you want. You can choose to have the system notify you when there is less than a 5-day supply of ink, or you can choose to ignore the warning.

### **2nd Low Ink Warning**

Repeat the above for 1.5 day notification.

### 10 Configuring System Timeouts

This section describes how to set various system timeouts for your mailing system.

1. To access the system timeouts, press the **Menu** key on the control center, and select **Set Up**.
2. Select **Basic Settings** and then **Timeouts** to get all of the timeout options.

The timeout options are listed on the right.

All of these options are described in the following sections.

Timeouts	
▶	Display Sleep
▶	System Sleep
▶	Normal Preset Timeout
▶	Feeding Timeout
▶	Waiting for Env
▶	Transaction Timeout

#### **Timeouts:** **Display Sleep**

This option allows you to specify how long the system can remain inactive before the display turns off. You can set the timeout for 1 - 30 minutes, in 1 minute increments. The default timeout is 5 minutes.

The display turns on again when you press any key on the control center or if you place mail in the feeder or on the scale (either integrated or attached external scale).

1. Press the **Menu** key and select **Set Up**.
2. Select **Basic Settings** and then **Timeouts**.
3. Select **Display Sleep**.
4. Enter the number of minutes (1-30) using the numeric keyboard.
5. Press the **Enter** key.

#### **Timeouts:** **System Sleep**

This feature may be offered as a standard or optional feature and is not available on all Pitney Bowes solutions. Please contact your local account representative to determine if this option is accessible on your system.

Use this option to specify how long the system can remain inactive before it goes into “deep-sleep” and removes power from the printer and the Postal Security Device (PSD).

You can set this timeout for 0 - 1440 minutes, in 1 minute increments. The default timeout is 30 minutes. The system goes into display sleep before it goes into system sleep.

The system wakes up again when you press any key on the control center or if you place mail in the feeder or on the scale (either integrated or attached external scale).

1. Press the **Menu** key and select **Set Up**.
2. Select **Basic Settings** and then **Timeouts**.

3. Select **System Sleep**.
4. Enter the number of minutes (0 - 1440 minutes) using the numeric keyboard.
5. Press the **Enter** key.

## **Timeouts: Normal Preset Timer**

The normal preset timer option allows you to specify how much time you want to allow the system to remain idle before it returns to the Normal Preset settings (refer to **11 Define Preset** section in this chapter for more information on Normal Presets).

You can set this timeout for 0 - 1440 minutes, in 1 minute increments. The default timeout is 30 minutes.

1. Press the **Menu** key and select **Set Up**.
2. Select **Basic Settings** and then **Timeouts**.
3. Select **Normal Preset Timer**.
4. To set a timeout, enter the number of minutes (0-1440) using the numeric keyboard.
5. If you want the system to stay at the last settings used, select **Never reset to Normal Preset**.
6. Press the **Enter** key.

## **Timeouts: Feeding Timeout**

Use this option to specify how much time to allow before the feeder stops after the last envelope is processed.

You can set this timeout for 5 - 90 seconds, in 1 second increments. The default timeout is 5 seconds.

This reduces the wear on your machine and acts as a safety measure if you leave the machine unattended.

1. Press the **Menu** key and select **Set Up**.
2. Select **Basic Settings** and then **Timeouts**.
3. Select **Feeding Timeout**.
4. Enter the number of seconds (0 - 90) using the numeric keyboard, or press the screen key corresponding to **Turn Rollers off Immediately**, or, **Run Until Stop key is Pressed**.
5. If you entered the number of seconds, press the **Enter** key.

### ***Timeouts:*** **Waiting for Env**

This option allows you to specify how long the system will continue to feed mail placed on the feed deck without having to press the **Start** key.

You can set this timeout for 0 - 90 seconds, in 1 second increments. The default timeout is 20 seconds.

1. Press the **Menu** key and select **Set Up**.
2. Select **Basic Settings** and then **Timeouts**.
3. Select **Waiting for Env**.
4. Enter the number of seconds (0 - 90) using the numeric keyboard.
5. Press the **Enter** key.

### ***Timeouts:*** **Transaction Timer**

This option is available only if your mailing machine is connected to the AccuTrac™ Mail Accounting system.

Use this option if you routinely batch your mail runs. This option allows you to specify how much time to allow the system to remain idle before it ends the current accounting transaction.

You can set this timeout for 10 - 65520, in 1 second increments. The default timeout is 14,400 seconds.

1. Press the **Menu** key and select **Set Up**.
2. Select **Basic Settings** and then **Timeouts**.
3. Select **Transaction Timer**.
4. Enter the number of seconds (10 - 65520) using the numeric keyboard.
5. Press the **Enter** key.

## 11 Defining Presets

You can define up to 10 sets (0 -9) of preset mailing system values, with each set having different values for such items as the account name, postage value, class, carrier, a special service, a mode such as **Attached Scale** or **Differential weighing**, and the like. You can use these presets for different mailing jobs.

The 0 preset is the normal preset and the one you use to store your most commonly used system values. These are the values your system will use whenever you restart your machine.

After you define all of your presets, you can invoke the normal preset values simply by pressing the **Normal Preset** key. To select any of the other presets, press the **Custom Preset** key and select the preset you want for the particular mailing operation.

### **How to Define Normal Preset Values**

1. Enter the values you use most often to run a mail job, for example, the weighing mode, the postage value, class and carrier etc.

---

**NOTE:** Proceed as if you were actually running a job. Select the mode and class and service etc. By doing this, you are entering the values that you will use for the normal preset. Refer to *Chapter 4, Running Mail* in this guide for more information on selecting mode and class.

---

2. Press the **Custom Presets** key.
3. A list of presets, starting with **0 Normal** appears. Do not press any of the screen keys corresponding to these presets.
4. Press the right arrow key (**Set up Presets** appears next to the right arrow key).
5. Press the screen key for **Store Current Setting to Preset**.

Select the normal preset by pressing the key for **0. Normal**. The "View Preset" screen appears and displays all of the values you defined in this session.

After a certain period of inactivity, or when you power up, the system restores the normal preset settings.

6. Press the **Enter** key to return to the main screen.

### Defining Presets

continued

#### ***How to Define Custom Preset Values***

1. Enter the values for the mail job (for example, the weighing mode, the postage value, class and carrier etc.) that correspond to the values you want to be able to call up in the future by selecting a custom preset key. For example, you may want to define a set of conditions so that the envelopes are sealed only (no postage applied).

---

**NOTE:** Proceed as if you were actually running a job. Select the mode and class and service etc. By doing this, you are entering the values that you will use for the normal preset. Refer to *Chapter 4, Running Mail* in this guide for more information on selecting mode and class.

---

2. Press the **Custom Presets** key.
3. Press the right arrow key.
4. Select **Store Current Setting to Preset**.
5. A list of presets, starting with **0 Normal** appears. Select one of the presets that has not been defined yet. These presets are named "Available". To change an existing preset, refer to *How to Edit a Custom Preset Value* in this section.
6. The system prompts you to: **Enter New Preset Name**.
7. Type in the name using the alphanumeric keys.
8. Press the **Enter** key. The "View Preset" screen appears and displays all of the values you defined in this session.  
To use these values in the future, simply press the **Custom Presets** Key and select the screen key corresponding to this preset name.
9. Press the **Enter** key to return to the main screen.

#### ***How to Store Advance Date in a Custom Preset***

This feature may be offered as a standard or optional feature and is not available on all Pitney Bowes solutions. Please contact your local account representative to determine if this option is accessible on your system.

In order to store an Advance Date setting in a custom preset, you need to first turn on this feature. For information on setting an advance date, refer to *Meter Stamp Options: Date* section in *Chapter 4* in this guide.

1. To enable this feature:
2. Press the **Custom Presets** key.
3. Press the right arrow key and the "Set Up Preset" screen opens.
4. Select **Date Advance**. The following message appears.  
"If set on, presets stored when the date is not advanced will return the system to today's date."

## Defining Presets

continued

5. Select On to turn on this feature and store the date advance.

Select Off if you want to turn off the feature.

Refer to the examples on the next page for more information on how storing the Advance Date in custom presets works.

---

**NOTE:** If you create a custom preset with the Advance Date feature turned off and you recall this preset, the current date setting is not affected.

---

### Example 1:

If today is Wednesday and you set the advance date for 2 days\* and store this advance in a custom preset, then:

- a.) if you recall the preset on the same day (Wednesday) it will print Friday's date on your postage.
- b.) if you recall the preset on the next day (Thursday) it will print Saturday's date on your postage.

---

\* To set advance date, press the **Menu** button, select **Meter Stamp Options**, then select **Advance Date**.

---

### Example 2:

If you have previously set up your system so that it automatically advances the date at 3 PM\*, and you created a custom preset with the Advance Date set to zero (that is, you did not advance the date), then:

- a.) if you recall the preset before 3 PM it will print today's date on your postage.
- b.) if you recall the preset after 3 PM it will print tomorrow's date on your postage.

---

\* To automatically advance the date (by 24 hours), press **Menu** button, select **Set Up**, press the down arrow key, then select **Date will advance after**.

---

### Example 3:

If you have previously set up your system so that it automatically advances the date at 3 PM, and you create a custom preset that advances the date by 2 days, then:

- a.) if you recall the preset before 3 PM, the system will set the date two days ahead.
- b.) if you recall the preset after 3 PM, the system will still set the date two days ahead.

### Defining Presets

continued

#### *How to Edit Custom Preset Values*

To edit an existing custom preset, you define its new values and then overwrite the old values.

1. Enter the new values for the mail job that correspond to the custom preset you want to change or edit.
2. Press the **Custom Presets** key.
3. Press the right arrow key (**Set up Presets** appears next to the right arrow key).
4. Press the screen key for **Store Current Setting to Preset**.
5. The system prompts you to "Select Preset to Replace".
6. Press the screen key next to the name of the preset you want to edit.
7. Press the **Enter** key to view the preset values. Press **Enter** again to return to the main screen.

#### *How to View, Rename, or Delete Presets*

1. Press the **Custom Presets** key.
2. A list of presets, starting with **0 Normal** appears. Select the appropriate preset. 0 - 4 presets are displayed on the screen. To view the other preset names, press the down arrow key.
3. Press the right arrow key (**Set up Presets** appears next to the right arrow key).
4. The following options appear:
  - Store Current Setting to Preset
  - View Preset
  - Rename Preset
  - Delete Preset
5. Select the screen key corresponding to the option you want. Follow the screen prompts.



### 12 Taking the Meter Out of Service

Call your Pitney Bowes representative if you need to return the postage meter (contained in the IntelliLink® Control Center) to Pitney Bowes. When instructed, follow the procedure here.

1. Press the **Menu** key and select **Set Up**.
2. Select **Take Meter Out of Service**.
3. Select **Transfer Funds from Meter**.

This transfers the funds from your meter back to your account.

4. The system transfers the funds and displays the amount transferred.
5. To print this amount on an envelope, place an envelope on the feed deck and press the **Start** key. To print on a tape, simply press the **Tape** key.

### 13 Adding an Optional Printer

You can connect a Pitney Bowes external laser printer to your mailing system. To add this optional external printer, all you need to do is plug the USB connector from the printer into one of the two upper-most USB connectors on the back of the mailing system base. Your mailing system recognizes the printer shortly after you plug it into the base.

The dual USB ports are located on the right back corner of the system base as shown here.



Dual External Device  
USB Ports

### 14 Configuring the Optional Barcode Scanner

If you have an optional barcode scanner attached to your DM500™ and DM550™ Digital Mailing System, you can configure it to scan in account names or account codes if you are using the optional Budget Manager or Business Manager accounting systems.

---

**NOTE 1:** You cannot scan in account names using a barcode scanner if you are using the Standard Accounting package provided with your system.

**NOTE 2:** You can use a barcode scanner to scan in barcodes for electronic confirmation services regardless of the accounting system you are using. Electronic confirmation services do not require any set up operations here.

---

Refer to the appropriate topic in this section:

- If you are using an accounting system on your DM500™ or DM550™ System you can set the default scan type so that your system recognizes your particular accounting application when it scans the barcode. Refer to *Setting the Default Scan Type*.
- If you are attempting to scan barcodes that were defined for other accounting systems and those accounts contain a prefix, you can set up your system to recognize that prefix when it scans in the barcode. Refer to *Adding Barcode Prefixes*.
- If you need to combine multiple barcode scans into a single barcode, refer to *Combining Barcodes*.
- If you want your system to require an operator to press the **Enter** key to accept each barcode value after it is scanned and displayed on the IntelliLink® Control Center screen, refer to *Setting Auto-Enter*.

**Setting the  
Default Scan  
Type**

If you are using an accounting system on your DM500™ or DM550™ System you can set up the scanner so that it interprets the barcode as an account name or account code. Your selection of Account Name or Account Code depends on your accounting system. You can then scan the account code or name directly from the Main screen on IntelliLink® Control Center display.

To set the default value:

1. Press the **Menu** key on the control center, then select **Set Up**.
2. Press the down arrow key and then select **Barcode Scanner**.
3. At the "Barcode Scanner Setup" menu, select **Default Scan Type**.
4. Select the appropriate option according to the table here:

<b>If your accounting system is:</b>	<b>And the barcode contains:</b>	<b>Select:</b>
Business Manager	Account Name	Account Name
Business Manager	Account Code	Account Code
Budget Manager	Account Name	Account Name
Budget Manager	Speed Code	Speed Code
AccuTrac™ Mail Accounting Software or MeterNet*	Account ID	Account ID
* For future release.		

5. If you do not want any default account system, or preset, select **None**.
6. As soon as you make your selection, the "Barcode Scanner Setup" menu reappears. You can make other selections or press the left arrow key to return to the "Set Up" menu.

### **Adding Barcode Prefixes**

If your barcodes include a 1 or 2-digit prefix, or if you want to create barcodes with a prefix, you can set up your system to recognize this prefix when you scan the barcode. This prefix identifies whether you are scanning in an account name or account code. You may use this if you are transferring accounts from a different accounting system like the Paragon, or from a set of pre-printed barcode labels that have a prefix as part of the barcode. You can then scan these barcodes directly from the Main screen on IntelliLink® Control Center display.

To set the prefix value:

1. Press the **Menu** key on the control center, then select **Set Up**.
2. Press the down arrow key and then select **Barcode Scanner**.
3. At the "Barcode Scanner Setup" menu, select **Barcode Prefixes**.
4. Select the **Prefix Size** and then select 1 or 2 whichever is appropriate.
5. Select the appropriate prefix option according to the table here:

<b>If your accounting system is:</b>	<b>And the barcode contains:</b>	<b>Select this Prefix Option:</b>
Business Manager	Account Name Prefix	Account Name Prefix
Business Manager	Account Code Prefix	Account Code Prefix
Budget Manager	Account Name Prefix	Account Name Prefix
Budget Manager	Account Speed Code Prefix	Account Code Speed Prefix
AccuTrac™ Mail Accounting Software or MeterNet ♦	Account ID Prefix	Account Name Prefix
Business Manager, Budget Manager, or AccuTrac™ Mail Accounting Software ♦	Job 1 Prefix	Job Id 1 Prefix
Business Manager or Budget Manager ♦	Job 2 Prefix	Job Id 2 Prefix
♦ For future release.		

6. When you select the prefix option, the default value for that option appears on the screen. To enter a new value, press the **Clear** key to remove the default, then type in the prefix character(s).
7. Press the **Enter** key.
8. As soon as you make your selection, the "Barcode Scanner Setup" menu reappears. You can make other selections or press the left arrow key to return to the **Set Up** menu.

## Combining Barcodes

If you need to combine multiple barcode scans into a single barcode, use this setup option. For example, the typical barcode scanner can only accept a maximum of 30 characters. If you want to scan an account name that contains more than 30 characters, say 50 characters, you add a "join character" at the end of the first 30 characters. These first 30 characters with the join character at the end, would be on the first line and the second 20 characters would be on the second line. When you scan these two barcode lines, the system will combine them into a single barcode account value.

To select the character to join multiple barcode scans:

1. Press the **Menu** key on the control center, then select **Set Up**.
2. Press the down arrow key and then select **Barcode Scanner**.
3. At the "Barcode Scanner Setup" menu, select **Concatenate Scans**.
4. A list of possible "join character" options is displayed. Select the character you use to combine the barcode values.
5. As soon as you make your selection, the "Barcode Scanner Setup" menu reappears. You can make other selections or press the left arrow key to return to the **Set Up** menu.

The following is an example using a + symbol as a join character.



When you scan in these 3 barcodes, the system will combine them into a single barcode value.

---

**NOTE:** When creating your own barcodes, create them in uppercase. If you create them in lowercase, the length of the barcode will be twice that of the same barcode created using uppercase text.

---

### **Setting Auto-Enter**

You can set up your system so that after it scans in a barcode value and displays it on the IntelliLink® Control Center screen, it requires you to press the **Enter** key to accept that value. You can do this if you want to be sure that an operator verifies that the correct barcode has been scanned. By default, the system will automatically enter the value as soon as it scans in the barcode.

To require you to press Enter to accept each scan:

1. Press the **Menu** key on the control center, then select **Set Up**.
2. Press the down arrow key and then select **Barcode Scanner**.
3. At the "Barcode Scanner Setup" menu, select **Auto-enter**.
4. Select Off to disable the Auto-enter. This will now require you to manually press the **Enter** key after each scan.

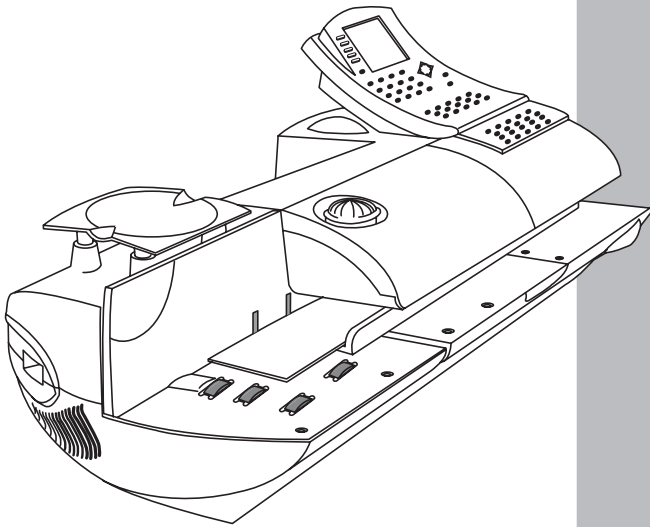

## 6 Adding Postage

### Contents

<i>Postage By Phone® Meter Payment System</i> .....	6-2
<i>Your Postage Meter</i> .....	6-2
<i>USPS Rekey Requirements</i> .....	6-2
<i>Managing Your Postage Funds</i> .....	6-3
<i>Connecting Your Postage Meter to an     Analog Phone Line</i> .....	6-4
<i>Checking Available Funds in Your     Postage Meter</i> .....	6-6
<i>Checking Your Postage By Phone®     System Account Balance</i> .....	6-7
<i>Adding Postage</i> .....	6-8

### Postage By Phone®

Postage By Phone® Meter Payment System is a Pitney Bowes service that you use to add postage to your meter. You can access the Postage By Phone® System 24 hours a day, 7 days a week through your IntelliLink® Control Center. For more information, refer to the Postage By Phone® System materials furnished with your system.

#### ***If you need assistance with Postage By Phone® System***

If you need assistance, have your account number ready and call the Postage By Phone® System number. Refer to the *Pitney Bowes Contact Information List* at the front of this guide for the phone number.

### Your Postage Meter

The postage meter on your mailing system is a Postal Security Device (PSD) that incorporates the latest technology approved by the United States Postal Service to secure funds. This technology eliminates the need to perform physical inspections thereby making the system easier and more convenient to use. The PSD contains the funds and performs all of the calculations necessary to print meter stamps that comply with the latest USPS standards.

The United States Postal Service (USPS) licenses your meter and requires a modem inspection of the meter. Each time you refill your meter or check your Postage By Phone® System account balance, the Pitney Bowes Data Center automatically performs a postal inspection.

If the meter in your mailing machine has not detected a modem refill transaction in 90 days, the message “Inspection Due” displays on the IntelliLink® Control Center main screen.

If the meter has not detected a refill in 120 days, the message “Inspection Required” displays and you cannot use your meter.

In either case you must perform a refill. If you don't need to add funds at this time, check your Postage By Phone® System account balance (see *Checking Your Postage By Phone® Meter Payment System Account Balance* in this chapter). This satisfies the inspection requirements.

If you have questions, call the Postage By Phone® System number. Refer to the *Pitney Bowes Contact Information List* at the front of this guide for the phone number.

### USPS Rekey Requirements

The United States Postal Service (USPS) also requires, for security reasons, that the meter keys expire after 3-6 years. Meter keys are cryptographic codes that your system uses to protect your funds during printing and when connecting to your account.

When the meter keys expire, the system reports that a rekey operation is required.

To rekey your meter, perform a refill. This upgrades the keys. If you do not perform a refill within three months of the rekey message, the system locks the meter and does not allow you to print postage.

You may still perform a refill to upgrade the keys and resume operation.



**Managing Your Postage Funds**

Refer to the appropriate section listed here for checking funds and account balances and adding postage when using the Postage By Phone® Meter Payment System.

<b>1</b>	<b>Connecting Your Postage Meter to an Analog Phone Line.</b> Refer to this section to see how to connect your postage meter to an analog line. This shows the recommended connections for when the analog line is close to your mailing system, and when you have to remove the IntelliLink® Control Center and take it to a remote location.
<b>2</b>	<b>Checking Available Funds in Your Meter.</b> Follow this procedure to see if you have sufficient funds in your meter.
<b>3</b>	<b>Checking Your Postage By Phone® System Account Balance.</b> Follow this procedure to see how many funds are in your account.
<b>4</b>	<b>Adding the Postage.</b> Follow this procedure to add postage from your Postage By Phone® System account to your postage meter.

### 1 Connecting Your Postage Meter to an Analog Phone Line

#### Connecting Your Postage Meter - Local Analog Phone Line Which connector do I use?

**Internal Analog Phone Line Connector** - Depending on the version of your IntelliLink® Control Center, you may have an internal analog modem. The *Internal Analog Phone Line Connector* label in the figure below identifies the PCN numbers of the IntelliLink® Control Centers that have an internal analog modem and can connect directly to an analog phone line. The PCN number is located on the bottom of your control center.

**External (Modem) USB Connector** - The IntelliLink® Control Center has a connector for a USB device. If the PCN number of your IntelliLink® Control Center is one of the ones listed under *USB Connector* label in the figure below, you must connect an external modem to this USB connector to dial into Pitney Bowes to perform feature updates or add postage. The PCN number is located on the bottom of your control center.

If your mailing system is not located near an analog phone line and you need to remove the control center when you perform feature updates or add postage, refer to *Connecting Your Postage Meter - Remote Analog Line* in this section.

Internal Analog Phone Line Connector

Use this to connect directly to an analog phone line if the PCN on the bottom of the control center has the number: 1DXX



IntelliLink® Control Center installed on a DM500™ or DM550™ Digital Mailing System base. Dotted line indicates AC Adapter Receptacle is covered by base

USB Connector

Use this to connect an external modem if the PCN on the bottom of the control center has the number: 1CXX

## **Connecting Your Postage Meter to an Analog Phone Line**

continued

### **Connecting Your Mailing System - Remote Analog Phone Line**

If you need to connect to an analog phone line that is not located near your mailing system, you can remove the IntelliLink® Control Center and move it to a location near the analog phone line. At the remote location, plug one end of the AC Adapter (P/N 1C85005) into the back of the control center and the other end into an AC outlet.

To remove the control center and move it to another location:

1. Turn off the power to the mailing system.
2. Pull the blue lever at the right of the control center towards you.
3. Slide the control center forward to remove it.



4. Take the control center (and external modem) to where the analog phone line is.
5. Depending on the PCN number of your IntelliLink® Control Center, connect the telephone cord (AWG 26) from either the external modem, or the internal analog connector to the analog telephone line.

Connect the A/C Adapter (P/N 1C85005) to the back of the control center and plug it into an AC outlet. Refer to the figure below.

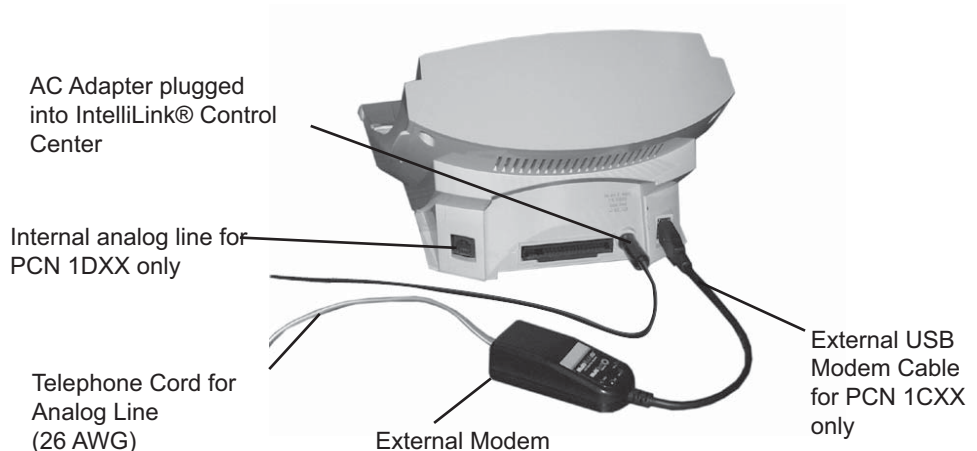

### Connecting Your Postage Meter to an Analog Phone Line

continued

6. Add or check your postage funds as described in *Checking Your Postage By Phone® Meter Payment System Account Balance* in this chapter.
7. Reinstall the IntelliLink® Control Center by sliding it into the docking station on top of the mailing system until you hear it click into place.
8. Turn the power back on.

### 2 Checking Available Funds in Your Postage Meter

If you are not sure if you have enough money to run mail or print tapes, you should check the amount of money (funds) in your postage meter.

To check available funds in your meter:

1. Press the **Funds** key. The amount of funds available in your postage meter displays in the main screen.
2. To print this amount on an envelope, place an envelope on the feed deck and press the **Start** key. To print on a tape, simply press the **Tape** key.
3. The system returns to the mailing screen.

If you do not have enough postage funds in your meter, check your Postage By Phone® Meter Payment System account balance (see **3** *Checking Your Postage By Phone® Meter Payment System Account Balance* in this chapter). If there are enough funds in your account, move funds to your postage meter (see *Adding Postage* in this chapter).

**3** **Checking  
Your  
Postage By  
Phone®  
Meter  
Payment  
System  
Account  
Balance**

Before adding postage to your meter, you should check the funds available through the Postage By Phone® System. Remember, with your new mailing system it is no longer necessary to prepay for postage. Your mailing system is designed to save you time and make adding postage to your meter even more convenient. Although you can still prepay, you can take advantage of the full meter capabilities and add postage now and be billed later. Please allow up to seven days for your check to post if you plan to add postage to your meter using pre-paid funds.

To check your account balance:

1. Press the **Funds** key.
2. Select **Get Postage by Phone® Balance**. The system dials Pitney Bowes to connect to your account. When the connection is made, the system displays your Postage By Phone® System balance.
3. Select **Done** to return to the main screen.

### 4 Adding Postage

To add postage from your Postage By Phone® System account to your postage meter, follow these steps.

1. Press the **Funds** key.
2. Select **Quick Refill**, or **Other Refill Amount**.
3. If you have set up a supervisor password, you are prompted to enter the password now.  
Enter the password and press the **Enter** key.
4. If you select **Quick Refill**, the system adds the same amount it did the last time you added postage.
5. If you select **Other Refill Amount**, use the number keys and enter in the amount you want to add (up to \$1000). Use whole dollars only; do not key in cents. Your meter automatically adds two decimal places.
6. Press the **Enter** key. The system dials Pitney Bowes to connect to your account and begins to add the postage to your meter.
7. The system notifies you when it finishes adding your postage and displays the message “Refill Complete”. The system prompts you to:  
**Press Tape to Print Tape**  
**Press Start to Print an Envelope**  
**Don't Print Receipt**
8. Select the appropriate option.

---

**NOTE:** To view or print a statement showing the details of the last five times you added postage to your meter, press the **Reports** key on the control center and select **Last 5 Refills**. Refer to *Chapter 8, Reports* in this guide for details of all system reports.

---

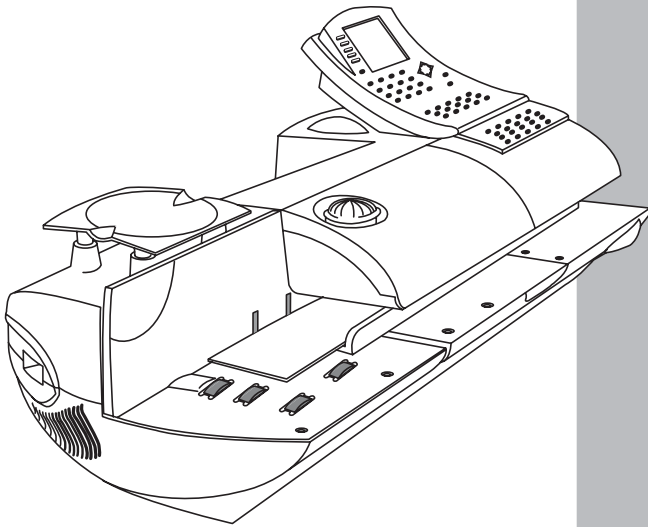

## 7 Standard Accounting Setup\*

### Contents

<i>Navigating Hints</i> .....	7-2
<i>Overview of Accounting</i> .....	7-3
<i>Using the Account Setup Procedures</i> .....	7-4
<i>Before Using the Setup Procedures</i> .....	7-4
<i>Viewing Accounts or Subaccounts</i> .....	7-5
<i>Creating Accounts and Subaccounts</i> .....	7-5
<i>Editing Accounts</i> .....	7-7
<i>Setting an Account Period</i> .....	7-8
<i>Turning Standard Accounting On or Off</i> .....	7-8
<i>Deleting Accounts and Subaccounts</i> .....	7-9
<i>Turning Account Password Protection On or Off</i> .....	7-9
<i>Resetting (Clearing) All Accounts</i> .....	7-10
<i>Turning Reset Individual Accounts On or Off</i> .....	7-10
<i>Transferring Funds</i> .....	7-11
<i>Setting the Station ID</i> .....	7-12
<i>Selecting Your Accounting Type</i> .....	7-13
<i>Your Accounting System Features</i> .....	7-14
<i>Account Structure and Hierarchy</i> .....	7-15

\* The information in this chapter applies only to the Standard Accounting application provided with your system. If you are using Budget Manager or Business Manager, refer to the documentation provided with those applications.

### Navigating Hints

- You can access all of the accounting features by pressing the **Accounts** key on the IntelliLink® Control Center. The system displays the account names in the format shown here (Standard Accounting):

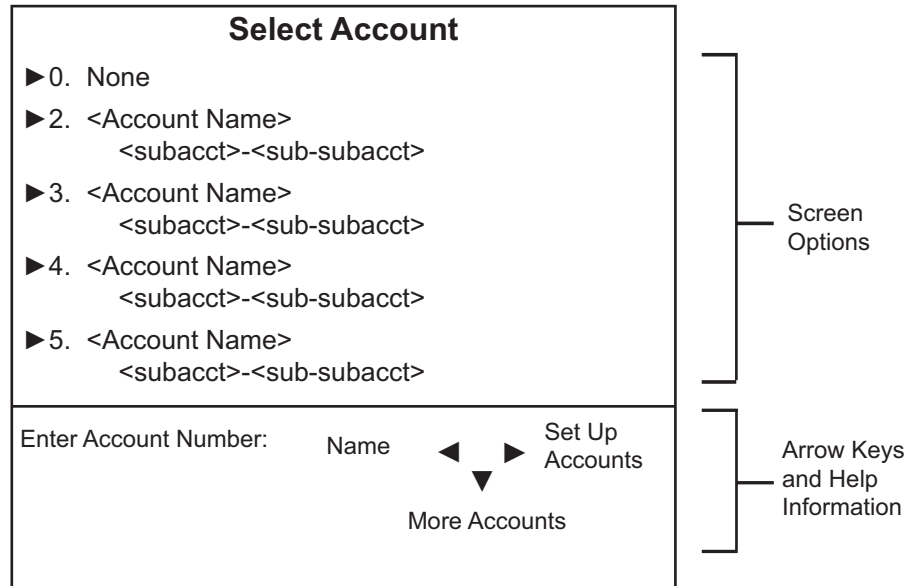

- To enter the account set up mode, press the right arrow key on the control center as indicated by the help information on the bottom on the right side of the main screen. The "Set Up Accounts" screen shown below appears:

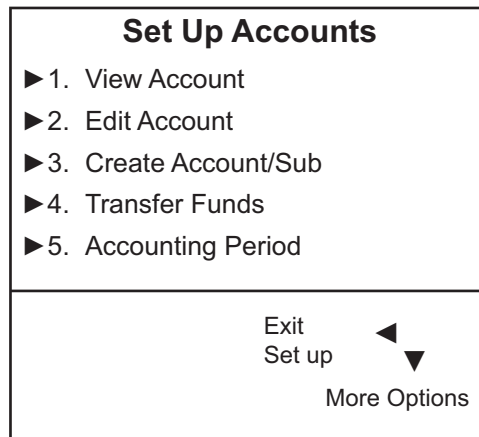

- The maximum number of options displayed is 5. To view more options, press the down arrow key.
- You can select a numbered option either by pressing the screen key next to the option, or by pressing the corresponding number on the keyboard and then pressing the **Enter** key.
- Pressing the left arrow key returns you to the main screen.



## Overview of Accounting

The information in this chapter describes how to set up the Standard Accounting package provided with your mailing system. If you purchased the enhanced accounting package, Budget Manager, or if your system is connected to an AccuTrac™ Mail Accounting Software SA system, or is part of the Business Manager system, refer to the documentation provided with these applications.

- For the Budget Manager, refer to SV60957.
- For the AccuTrac™ Mail Accounting System SA, refer to SV60514.
- For Business Manager, refer to SV61178.

For information on your system's accounting features, or if this is the first time you are setting up accounts and would like some examples of accounting structures and hierarchy see sections: *Your Accounting System Features and Account Structure and Hierarchy* at the end of this chapter.

To begin using the account setup procedures, go to *Using the Account Setup Procedures* starting on the next page.

### Using the Account Setup Procedures

The following is a list of all the account setup procedures. For details on each procedure, refer to the section number listed here.

1	Viewing Accounts or Subaccounts.
2	Creating Accounts and Subaccounts.
3	Editing Accounts.
4	Setting an Accounting Period.
5	Turning Accounting On or Off.
6	Deleting Accounts.
7	Turning Account Password Protection On or Off.
8	Resetting (Clearing) All Accounts.
9	Turning Reset Individual Accounts On or Off.
10	Transferring Funds.
11	Setting the Station ID.
12	Selecting an Accounting Type.

### Before Using the Setup Procedures

1. If your system has a supervisor password set up, you must enter that password before you can enter the account setup mode.

---

**NOTE:** Passwords are case-sensitive.

---

2. If you have not set up any accounts yet, as soon as you press the **Accounts** key on the control center, the system prompts you for the supervisor password. As soon as you enter the password, the system displays the "Set Up Accounts" screen.
3. If you have already set up accounts, pressing the **Accounts** key displays a list of all the accounts. Press the right arrow key to enter the "Set Up Accounts" screen.

**1 Viewing Accounts or Subaccounts**

1. Press the **Accounts** key.
2. Press the right arrow key to enter the “Set Up Accounts” screen.
3. Select **View Accounts**.
4. The names of your top level accounts appear. Select the account you want.
5. The system displays the total funds and total pieces for that account which includes the rolled up totals for all its subaccounts and subsubaccounts. If the account has subaccounts, you can also select **View Subaccount** and **View Subsubaccount** to get the information for each.

**2 Creating Accounts and Subaccounts**

To create a new account:

1. Press the **Accounts** key.
2. Press the right arrow key to enter the “Set Up Account” screen.
3. Select **Create Account/Sub**.
4. Select **Create a New Account**. The system prompts you to enter an account name.
5. Type in the name using the keyboard or numeric keypad and press **Enter**. The “Account Information” screen appears and displays the options:
  - Edit Name
  - Edit Number
  - Add | Change Password
  - Add Subaccount (to account) | Subsubaccount (to subaccount)
  - Create Another Account | Subaccount | Subsubaccount
6. Select the appropriate option and follow the prompts.

---

**NOTES:**

- a. By default, the system assigns the next available account number to your new account. If you want to assign a different number, select the **Edit Number** option.
  - b. If you want to password protect this account, select the **Add Password** option. You will be prompted to enter a password and then confirm it. Passwords are case sensitive, can be alphanumeric and must be at least four characters. (You need to enable password protection before you can protect an individual account. Refer to **7 Turning Accounting Password Protection On or Off** in this chapter.)
- 

7. When you are done, press the **Enter** key to save the account information.

### 2 Creating Accounts and Subaccounts

continued

To create a new subaccount or subsubaccount:

1. Press the **Accounts** key.
2. Press the right arrow key to enter the “Set Up Accounts” screen.
3. Select **Create Account/Sub**.
4. Select **Add to an Existing Account**. The system displays a list of all of the accounts and prompts you to select the account to which you would like to add a subaccount or subsubaccount.  
If necessary use the down arrow key to scroll down through the list.
5. Select the account or subaccount.
6. Type in the name of the subaccount or subsubaccount and press **Enter**. The “Account Information” screen appears and displays the options:  
Edit Name  
Number:  
Add SubSubaccount to:  
Add | Change Password  
Create Another Subaccount for:
7. Select the appropriate option and follow the prompts.

---

#### NOTES:

- a.) The account number and password, and total pieces and funds used (if they exist) are transferred to the first subaccount created (the next working, chargeable, account). They are further transferred down when a subsubaccount in this link is created (the new chargeable account).
- b.) By default for addition subaccounts, the system assigns the next available account number to your new subaccount.
- c.) If you want to password protect this account, select the **Add Password** option. You will be prompted to enter a password and then confirm it

- 
8. When you are done, press the **Enter** key to save the account information.

### Accounting Messages

When you attempt to create an account when all available accounts have been used, the message “Cannot create any more accounts” appears. You must delete an account before you can create another account. Alternatively, if you have fewer accounts than you system is capable of handling, you can upgrade to a higher number of accounts.

## 3 Editing Accounts

You can change the name of an account, make the account inactive (or active), add a password or change an existing one, and clear (reset) all data from the account.

1. Press the **Accounts** key.
2. Press the right arrow key to enter the “Set Up Account” screen.
3. Select **Edit Account**.
4. The names of your top level accounts appear. Select the account you want to edit.
5. Select the appropriate option:
  - a.) **Edit Account Name** - Select this to change the name of your account. (Only the chargeable account name can be changed. A new account with its own subaccounts/subsubaccounts is necessary for new high level account names.)
  - b.) **Status** - Select this to change the account’s status to Active or Inactive. Pressing the screen key for Status switches between active and inactive.
  - c.) **Reset Account** - Select this to clear all number of pieces and funds in this account. When you select this, the system prompts you to print a report of the account data. Once cleared, the data are unrecoverable. To keep a record of your data, select **Print Report**, then select **Reset** to clear the data.

Before you can reset or clear individual accounts, you must enable this feature. Refer to **9** *Turning Individual Reset Accounts On or Off* in this chapter.
  - d.) **Change | Add Password** - This option allows you to change an existing password or create one for this account. Passwords are case sensitive, can be alphanumeric and must be at least four characters. You are prompted to confirm the new or modified password.

---

**NOTE:** Before you can create or change a password, you must enable this feature. Refer to **7** *Turning Account Password Protection On or Off* in this chapter.

---

### 4 Setting an Account Period

By default, your mailing system does not have an account period set. If you set an account period, when your system reaches the end of that period, you need to reset (clear) all of the data in the accounts before you can process mail again.

To set an account period:

1. Press the **Accounts** key.
2. Press the right arrow key to enter the “Set Up Accounts” screen.
3. Select **Accounting Period**.
4. Select the appropriate accounting period (none, weekly, monthly, quarterly, twice a year, or yearly).
5. The system calculates the cutoff date. If you want to type in another cutoff date press the clear button and enter a cutoff date using the format:

**MM DD YYYY**

---

**EXAMPLE:** If you selected a monthly accounting period and entered a cutoff date of 03 31 2004, as soon as your system reaches April 1, 2004 (12:01 a.m.), you must reset (clear) your account data. Your machine prompts you to do so at startup. Once you reset the accounts, the system automatically resets the cutoff date to 04 30 2004.

---

6. Press **Enter**.

### 5 Turning Standard Accounting On or Off

To turn the standard accounting package provided with your system on or off:

1. Press the **Accounts** key.
2. Press the right arrow key to enter the “Set Up Accounts” screen.
3. Scroll down and select **Accounting**.
4. To turn on the system’s standard accounting, select **Standard**. To disable or turn off standard accounting, select **Off**.

**NOTE:** If your system is connected to other accounting systems, those systems also appear as options. Refer to **12** *Selecting an Accounting Type* in this chapter for more information.

---

**6** **Deleting  
Accounts  
and  
Subaccounts**

When you delete an account, you remove its data completely. That data is then unrecoverable. Make sure you do not need the account's data before you delete the account.

To delete an account:

1. Press the **Accounts** key.
2. Press the right arrow key to enter the "Set Up Account" screen.
3. Scroll down and select **Delete Account**.
4. A list of your accounts appear. You can only select a chargeable account to delete. The selected account, subaccount and/or subsub-account, along with its postage and pieces of mail is deleted.

---

**EXAMPLE:**

The subaccounts appear in the display as two separate accounts under the main account title:

<b>Engineering</b>	<b>Software</b>
<b>Engineering</b>	<b>Industrial Design</b>

---

5. As soon as you select an account, the system prompts you to print a report. Once you delete an account, its data cannot be retrieved. To keep a record of your account data, select **Print Report**, then select **Delete**.

**7** **Turning  
Account  
Password  
Protection  
On or Off**

By turning passwords on, you can protect each account from unauthorized access.

---

**NOTE:** Before you can turn account password protection on or off, you need enable the supervisor password protection feature. Refer to **4** *Setting up a Supervisor Password* in Chapter 4 of this guide for more information.

---

To turn account passwords on or off:

1. Press the **Accounts** key.
2. Press the right arrow key to enter the "Set Up Account" screen.
3. Scroll down and select **Passwords**.

By selecting Passwords, you can switch between **On** and **Off**.

### 8 Resetting (Clearing) all Accounts

When you reset or clear your accounts, you completely remove all of the data in all of your accounts. Once you clear the data, you cannot retrieve it. To keep a record of your data, be sure and print a Multi-Account Summary Report. Refer to *Chapter 8, Reports* for more information on reports.

To reset or clear all of your accounts:

1. Press the **Accounts** key.
2. Press the right arrow key to enter the “Set Up Accounts” screen.
3. Scroll down and select **Reset All Accounts**.
4. As soon as you select Reset All Accounts, the system prompts you to:  
Print Report  
Reset
5. To keep a record of your account data, select **Print Report**. The system prints a Multi-Account report.
6. Once you print a Multi-Account report, clear all accounts by selecting **Reset**. The system prompts you to confirm that you want to clear the accounts.

### 9 Turning Reset Individual Accounts On or Off

If you want to be able to reset (clear) individual accounts, enable (turn on) the Reset Individual Accounts feature.

1. Press the **Accounts** key.
2. Press the right arrow key to enter the “Set Up Accounts” screen.
3. Scroll down and select **Reset Indiv. Accounts**.

By selecting Reset Indiv. Accounts, you can switch between On and Off.

---

**NOTE:** To reset individual accounts, refer to **3** *Editing Accounts* in this chapter.

---



**10** Transferring Funds

To transfer funds:

1. Press the **Accounts** key.
2. Press the right arrow key to enter the “Set Up Accounts” screen.
3. Select **Transfer Funds**. The system displays a list of your chargeable accounts. You can transfer funds used and piece count among accounts, subaccounts and subsubaccounts only if they are working accounts (the lowest, or sole link in the account chain).

---

**EXAMPLE:**

If you have a top level account with two subaccounts and one subsubaccount:

Account - Engineering, Subaccount - **Software**

Account - Engineering, Subaccount - **Industrial Design**

Account - Engineering, Subaccount - Mechanical,  
Subsubaccount - **Prototypes**

The subaccounts and subsubaccount appear in the display as separate accounts under the main account title: transfers can be made among **Software, Industrial Design** and **Prototypes**.

Engineering

**Software**

Engineering

**Industrial Design**

Engineering

Mechanical

**Prototypes**

---

4. Select an account to transfer funds from and press **Enter**.
5. The system displays a list of all of your accounts again. Select an account to transfer funds to and press Enter.
6. A screen displays showing your “transfer from” and “transfer to” accounts.
7. Select **Transfer Entire Amount**, or:  
if you want to transfer less than the entire amount, enter the amount you wish to transfer and press **Enter**.  
The system displays a screen of the from/to accounts and the amount of the transfer.
8. Select **Transfer \$\_\_\_\_\_**. The system transfers the amount and displays a screen of the accounts and amount transferred.

To transfer pieces:

9. Select **Transfer Piece Count**. The system displays a screen of the same accounts and prompts you to “Enter Number of Pieces to Transfer.”  
Enter the number of pieces or select **Transfer Entire Piece Count** and press **Enter**.
10. The system displays a screen of the from/to accounts and the piece count of the transfer.
11. Select **Transfer \_\_\_\_**. The system transfers the pieces and displays a screen showing the transaction.

### **11** Setting the Station ID

If you have multiple mailing systems, the Station ID provides you with a way of identifying each system. The Station ID appears on accounting reports.

1. Press the **Accounts** key.
2. Press the right arrow key to enter the “Set Up Accounts” screen.
3. Scroll down and select **Set Station ID**.
4. Type in a unique alphanumeric identification, up to two characters in length and press **Enter**.

**12** **Selecting an Accounting Type**

To select and accounting type, or to disable the accounting feature on your mailing system, follow the procedure here.

1. Press the **Accounts** key.
2. Press the right arrow key to enter the “Set up Account” screen.
3. Scroll down until you see the Accounting selection. The type of accounting currently set for your system is displayed next to the Accounting selection.
4. Press the screen key for **Accounting**. The “Select Accounting Type” screen appears and depending on the option(s) you purchased, displays the following:  
Off  
Standard  
Business Manager  
Budget Manager  
AccuTrac  
Meternet
5. To disable the current accounting, select Off.

---

**NOTE:** If accounting is enabled, whenever you run mail you **MUST** select an account. To avoid having to do this, select Off.

---

6. To enable the standard accounting provided with your system, select **Standard**.  
If you have purchased Business Manager, select **Business Manager**.  
If you have purchased Budget Manager, select **Budget Manager**.  
If you have an AccuTrac SA connected to your system, select **AccuTrac**.



**CAUTION:** If you switch from one accounting system to another, you will lose all of the data in the original accounting system..

---

### **Your Accounting System Features**

You can configure your mailing system to track and account for postage used by departments or individuals within your organization. Your system stores the following information for each account.

- Account name (alphanumeric)
  - 32 characters for top level accounts
  - 16 characters for subaccounts
  - 16 characters for subsubaccounts
- Account ID number
- Item total. This is the total number pieces of mail charged to an account since it was last cleared.
- Value total. This is the total amount of postage charged to an account since it was last cleared.
- Account password.

Your mailing machine has 25 standard accounts. You have the option to increase your accounts to 100 or 300 accounts. Only your chargeable level accounts are counted towards your account total. (Chargeable accounts are explained in the next section.)

If you need information on how to structure your accounts, refer to the *Account Structure and Hierarchy* section in this chapter.

## **Account Structure and Hierarchy**

You can structure your accounts in single or multiple levels. For example, you can divide a top level department (account) into two or more major sections or subaccounts. You can further divide these subaccounts into two or more sections or subsubaccounts. The following examples demonstrate some of the ways in which you can structure your accounts.

- When you create a top level account, you can charge funds and pieces to that account. This is the working (chargeable) account because at this point it does not have any subordinate accounts:

**EXAMPLE: Account - Engineering**

- If you create subaccounts for the original account, they become the end links in the account chain and identify the departments where you disperse funds:

**EXAMPLE: Account - Engineering, Subaccount - Software**

Account - Engineering, Subaccount - **Industrial Design**

The original Account now serves as an administrative account that owns and contains totals for the lower subaccounts.

- If you create subsubaccounts for subaccounts, the subsubaccounts become the end links and identify the departments that are charged for postage.

**EXAMPLES:**

Account - Engineering, Subaccount - Software,  
Subsubaccount - **Software Testing**

Account - Engineering, Subaccount - Software,  
Subsubaccount - **Software Design**

Account - Engineering, Subaccount - Industrial Design,  
Subsubaccount - **Graphics and Layout**

Account - Engineering, Subaccount - Industrial Design,  
Subsubaccount - **User Friendly Testing**

When accounts are linked (account/subaccount, or account/subaccount/subsubaccount) they become a set and are treated as one separate account, with one account number and one password. The existing account number and password are rolled down to the subaccount when the first subaccount is created. When you create another subaccount to this account, you create another linked set of accounts with a different account number and password.

This type of account structure allows you to view accounts and create reports that show total charges for the top level account, or you can view or create reports that show the charges for each of the subaccounts or subsubaccounts. This is graphically illustrated on the following page using the above examples.

You can have all single top level accounts or you can mix both single and multi-layered accounts. The lowest level in the account structure is where charges are incurred. An account or subaccount, just like the subsubaccount is the chargeable account when it's the last, or single, link in the structure. Piece count totals and funds used are transferred among accounts, subaccounts and subsubaccounts when they are chargeable accounts.

When you use an account to print postage, you are using the chargeable account in a link of accounts (e.g., Engineering/Industrial Design/Graphics and Layout) to draw from the meter's postage funds obtained through Postage By Phone®.

When you view accounts or print reports you are being given information on funds used and pieces processed for each account in the hierarchal structure. For example, (Engineering) with totals for all its subaccounts and subsubaccounts. The subaccounts (e.g., Industrial Design) show totals for their subsubaccounts (e.g., Graphics and Layout and User Friendly Testing) and the subsubaccounts show their individual totals.

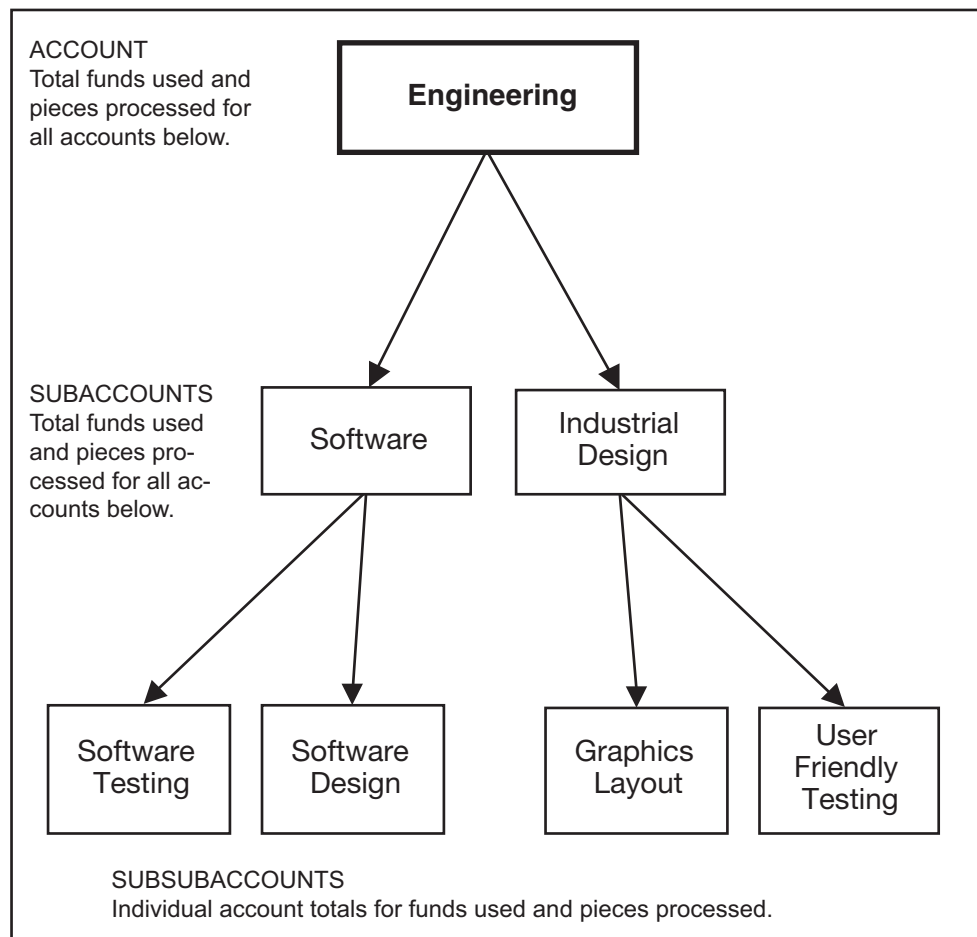

### Hierarchal Reporting Structure

---

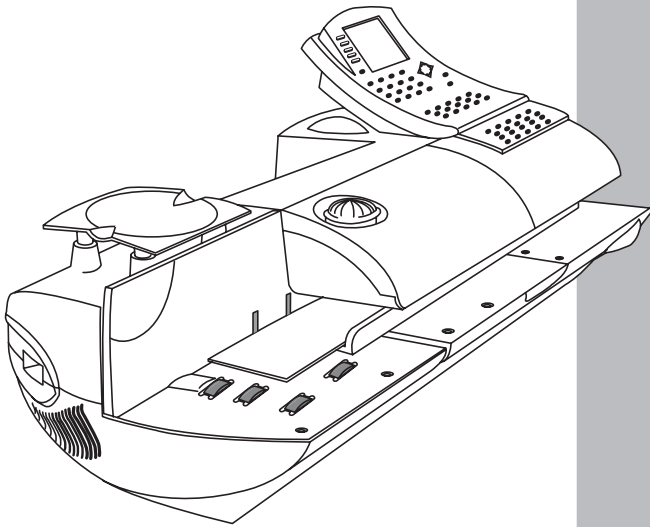

## 8 Reports

### Contents

<i>Introduction</i> .....	8-2
<i>Printing a Report</i> .....	8-2
<i>Single Account Report</i> .....	8-3
<i>Multi-Account Summary</i> .....	8-4
<i>Last 5 Refills Report</i> .....	8-6
<i>USPS Confirmation Services Report</i> .....	8-7
<i>Permit Mail Report</i> .....	8-8
<i>Account List Report</i> .....	8-8
<i>Funds Report</i> .....	8-9
<i>System Setup Report</i> .....	8-10
<i>Error Report</i> .....	8-11
<i>Job Report</i> .....	8-12
<i>Data Capture Short Report</i> .....	8-13

### Introduction

Creating a report is quick and easy on your mailing system. With the capability to print out reports on roll tape or envelopes using the internal mailing system printer, you can easily keep an accurate record of all your mailing activities.

---

**NOTE:** The accounting reports described in this chapter are for the Standard accounting package provided with your DM Series™ Digital Mailing System. If you are using another optional accounting package (for example, Budget Manager), refer to the documentation provided with that application.

---

For some reports, you need an external or attached printer. For instructions on how to set up an attached printer, refer to *Chapter 5 - Mailing System Setup, Set Up Optional Printer*, in this guide.

Each report is described in the following sections. Each section shows you the display on the screen and the information that prints out.

#### ***How To View a Report***

1. Press the **Reports** key.
2. Select the report you want to print. The report appears in the main display.

### Printing a Report

You may print reports using the internal mailing system printer, or an attached external printer if one is connected to your system.

#### ***How to Print a Report***

1. Press the **Reports** key.
2. Select the report you want to print. The report appears in the main display. Press **Enter**.
3. Depending on your particular system, select one of the bulleted options below.
  - If your system can only print using the internal mailing system printer: press the **Start** or **Tape** key to print on an envelope or tape.
  - If you have an external printer and your report can only print to an external printer, the system asks you to press **Enter**.
  - If you have an external printer and your report can print to an external printer or the internal printer, the system asks you to "Select a Printer."
4. If you want to use the attached external printer, select **Attached Printer**. Press **Enter**.

If you want to use the system printer, select **Mailing Machine**. Press the **Start** or **Tape** key to print on an envelope or tape.



## Reports

### **Single Account Report**

The Single Account Report gives the total pieces of mail and the postage for a selected account. After you select **Single Account Report** the last account used is displayed. To view another account, press the screen key for **Select Another Account**.

If you have re-powered the system since the last time you processed mail, the "Select Account" screen displays. Use this screen to choose a specific account for the report.

Accounts can be printed even if they are inactive.

#### **Screen Display**

```
Single Account Report
  <Account name>
  <Subacct> <Sub-Subacct>

  Account Number    <Account Number>
  Pieces            <Account Piece Count>
  Postage           <Account Value Total>

  > Select Another Account
```

#### **Printed Report**

The Single Account Report prints on one envelope or a strip of tape.

Information contained in the report:

- Date report is printed.
- Time report printed.
- Meter Stamp Serial Number: identifies the meter which printed the report.
- Account Number: Number of each account that has used postage.
- Pieces: Total of pieces processed for the account.
- Postage: Total postage amount charged to the account.
- Station ID: a user-defined number to identify the meter.

### **Multi-Account Summary** (Internal printer version)

The Multi-Account Summary supplies the total pieces and postage for all enabled accounts.

This report can be printed on an envelope with the internal printer.

#### ***Screen Display***

<b>Multi-Account Summary</b>		
Account	Pieces	Postage
<Account Number>	<Account Piece Count>	<Postage Value Total>
<Account Number>	<Account Piece Count>	<Postage Value Total>
<Account Number>	<Account Piece Count>	<Postage Value Total>
<Account Number>	<Account Piece Count>	<Postage Value Total>

#### ***Printed Report***

- Date report is printed.
- Time report is printed.
- Meter Stamp Serial Number: identifies the meter which printed the report.
- Account Number: Number of each account that has used postage.
- Pieces: Total of pieces run for account.
- Postage: Total postage value for account; no sub total is provided for subaccounts or sub-subaccounts.
- Station ID: a user-defined number to identify the meter.
- Page numbers.

---

**NOTE:** The account name only appears on the report when you print the report on an external printer.

---

**Multi-Account  
Summary  
(External Printer  
Version)**

This version of the Multi-Account Summary can only be printed on an attached external printer. Account numbers are only assigned to the lowest level of the account hierarchy or transaction level. Account numbers will only appear if the account does not have subaccounts. If the account has subaccounts or subsubaccounts, account numbers will only be displayed for the lowest level account. The piece and postage totals for accounts with subaccounts displays as "Subtotal."

**Screen Display**

<b>Account Summary</b>		
Account	Pieces	Postage
<Account name>	<Account Piece Count>	<Postage Value Total>
<Account name>	<Account Piece Count>	<Postage Value Total>

**Printed Report**

The Multi-Account Summary prints out on an attached printer. This report provides the following information:

- Meter stamp number.
- Date report is printed.
- Time report is printed.
- Page number.
- Station ID: a user-defined number to identify the meter.
- Number assigned to an account, subaccount, or sub-subaccount.
- Name of the account, subaccount, or sub-subaccount.
- Total of Items of mail for account, subaccount, or sub-subaccount.
- Amount of funds used in account.
- Total of funds used for each level of accounts.
- The grand total of pieces of mail.
- The grand total of the funds used.

## Last 5 Refills Report

The Last Five Refills Report lists the last five refills for any enabled account and prints the information on a single envelope or strip of tape. The refills are displayed in chronological order.

### Screen Display

Last 5 Refills Report		
Date	Time	Amount
<Date>	<Time>	<Refill Amount>
<Date>	<Time>	<Refill Amount>
<Date>	<Time>	<Refill Amount>
<Date>	<Time>	<Refill Amount>
PbP Account:	<Account>	

### Printed Report

The Refill Statement provides the following information:

- Date of Refill.
- Time of Refill.
- Refill Amount: Amount of the last five refills for this particular account.
- Account No: Postage By Phone® Meter Payment System account number.
- Meter Stamp Serial Number: identifies the meter which printed the report.
- Date Printed.
- Page number of report.

## **Confirmation Services Report System Printer**

The Confirmation Services Report provides details for Confirmation Services pieces processed and uploaded via IntelliLink® Control Center. It prints the information on an envelope or strip of tape.

When you select Confirmation Services from the "Select Report" screen, you can choose one of the following options:

- **View or print a specific record** - You can scroll through the uploaded records one at a time. You can print to a tape or envelope.
- **Print receipts for last batch sent** - If a tape is loaded, the system prints the receipts.
- **Print summary to attached printer** - You must have an external printer attached.

### **Screen Display**

<b>Confirmation Services Report</b>	
Barcode:	
Service:	
Postage:	
Class:	
ZIP:	
Date Uploaded:	
> Print tapes for last group sent	

### **Printed Report: System Printer**

- The report provides the following information about a piece of mail:
- Barcode or package identification code.
- Destination ZIP Code of the package.
- The Postage by Phone® Meter Payment System account number.
- Meter Serial number.
- Date and time record was uploaded via IntelliLink® Control Center.
- A fill-in space where the customer can write in the recipient and delivery address.

### **Printed Report: Attached Printer**

The external printer version of the USPS Services Report provides the following information for each package:

- Package identification barcode.
- Amount of postage used.
- Class of mail for the package.
- Type of Special Service used.
- Destination ZIP Code.
- Date package was uploaded via IntelliLink® Control Center.

## Permit Mail Report

This feature may be offered as a standard or optional feature and is not available on all Pitney Bowes solutions. Please contact your local account representative to determine if this option is accessible on your system.

The Permit Mail Report provides a piece count on up to three permits. Use the up/down arrow keys to scroll through the permits.

The report prints on one envelope or strip of tape.

### Screen Display

Permit Mail Report	
Permit Number	<Permit Number>
Permit Name	<Permit Name>
Counter	<Permit Batch>
Total Pieces	<Permit Piece Count>

### Printed Report

The Permit Mail Report provides the following information:

- Permit Name: Identifying Text for each active permit mail class.
- Counter: Resettable Permit Mail Piece Count for each active permit mail class.
- Total Pieces: Non-resettable Permit Mail Piece Count for each active permit mail class.
- Date Printed.
- Time Printed.
- Meter Serial Number.

## Account List Report (External Printer Required)

The Account List Report lists the names and numbers of all accounts that are set up in your mailing machine.

### Screen Display

Account List	
Number	Name
<Account Number>	<Account Name>
<Account Number>	<Account Name>
<Account Number>	<subaccount>
<Account Number>	<subsubaccount>

### Printed Report

This report prints a list of all your accounts and the account numbers.

## **Funds Report**

The Funds Report gives a summary of the funds used and available in the meter, total pieces run, batch pieces and value. It prints on one envelope or tape.

### ***Screen Display***

<b>Funds Report</b>	
Funds Used:	<Funds Used>
Funds Available:	<Funds Available>
Total Pieces:	<Total Pieces>
Control Sum:	<Control Sum>
Batch Count:	<Batch Count>
Batch Value:	<Batch Value>

### ***Printed Report***

The Funds Report provides the following information:

- Date report is printed.
- Time report is printed.
- Meter Stamp Serial Number.
- Used: Postage funds currently spent.
- Available: Postage funds still available for processing.
- Control Sum: The total of used funds and available funds.
- Total Pieces: Total of pieces imprinted with postage.
- Batch Value: Postage spent for this batch.
- Batch Count: Number of pieces in the batch.
- Postage By Phone® Meter Payment System serial number.

### System Setup Report

The System Setup Report is an extensive report that gives you comprehensive information about your total mailing system. You can only the entire system set up. However, the entire report must be printed on an attached printer. It provides information on:

- **Serial Numbers:**  
Meter, IntelliLink® Control Center, Meter Stamps, Base, and Postal Security Device.
- **Software Versions:**  
IntelliLink® Control Center, Postal Security Device, Scale Software, Rates Module.
- **Downloaded Features:**  
Features, Rates, Software, Scale Capacity, Number of Uploaded Records.
- **Funds and Piece Information:**  
Funds Used, Funds Available, Control Sum, Total Pieces, Batch Value, Batch Count.
- **Warning Values:**  
High Value, Low Funds, Maximum Settable Value.
- **Time Settings:**  
Time Zone Offset, Daylight Time Offset, Daylight Savings, Clock Drift Adjustment, Date Advance Time.
- **Advertisements:**  
Advertisement ID and Name.
- **Inscriptions:**  
Inscription ID and Name.
- **Accounting Set Up:**  
Accounting Feature on/off, System, Passwords, Number of Accounts.
- **Modem Set Up:**  
Dial Out Prefix, Dial Method, Local Number, Pitney Bowes Number, PBP Account, Initialization String.
- **Scale Settings:**  
Adjustment for Motion, AutoScale, Trip Weight, Units, Origin, Location Code, AutoClear, Clear Zone If New Class, ZIP/Zone Prompt, BMC Intra ZIP, Add ZIPs to Zone ), Discount Code, Min. Confirmation Service, Scale Capacity.
- **Presets.**



## **Error Report**

This feature may be offered as a standard or optional feature and is not available on all Pitney Bowes solutions. Please contact your local account representative to determine if this option is accessible on your system.

The Error Report lists the last ten errors in chronological order with the most recent error at the top. It prints on an envelope or tape strip.

### **Screen Display**

<b>Error Report</b>			
Date	Time	Location	Error ID
<Date>	<Time>	<Location>	<Error Code>
<Date>	<Time>	<Location>	<Error Code>
<Date>	<Time>	<Location>	<Error Code>
<Date>	<Time>	<Location>	<Error Code>

### **Printed Report**

The Error Report gives the following information:

- Date report printed.
- Time report printed.
- Meter Stamp Serial Number.

The Error Report lists the following information for each error:

- Error Date.
- Error Time.
- Error Identification.
- Location: Where in the system the error occurred.
- Page Numbers.

### Job Report

This feature may be offered as a standard or optional feature and is not available on all Pitney Bowes solutions. Please contact your local account representative to determine if this option is accessible on your system.

The Job Report summarizes a job that is processed in a mode that did not dispense funds. It can be printed on an envelope or tape.

#### **Screen Display**

<b>Job Report</b>	
<Account Name>	
<SubAccount>	<Sub-SubAccount>
Account Number	<Account Number>
Pieces	<Account Piece Count>
Job:	<Mode>

#### **Printed Report**

The Job Report gives the following information:

- Time: date printed report printed.
- Meter Stamp Serial Number: identifies the meter which printed the report.
- Station ID: A user-defined number to identify the meter.
- Pieces: Total of pieces processed for the account.
- Postage: Total postage amount charged to the account.
- Job: mode of operation.
- Account Number: Number of each account that has used postage.
- Account Name: Name of each account that has used postage.

**Data Capture  
Report  
(Non-US Use  
Only)**

The Data Capture Short Report provides information on the data that is transferred from the mailing system through Pitney Bowes Data Center to the Post Office.

The Data Capture Report prints on an envelope or tape.

***Installed/Pending Rates***

This report displays only on the screen.

Rate:

Description (name)

File Name

Part Number

Version

Service level

Effective date

Active or Inactive

***Last Rates Downloaded***

This report displays only on the screen.

***View Download Log***

This report displays only on the screen.



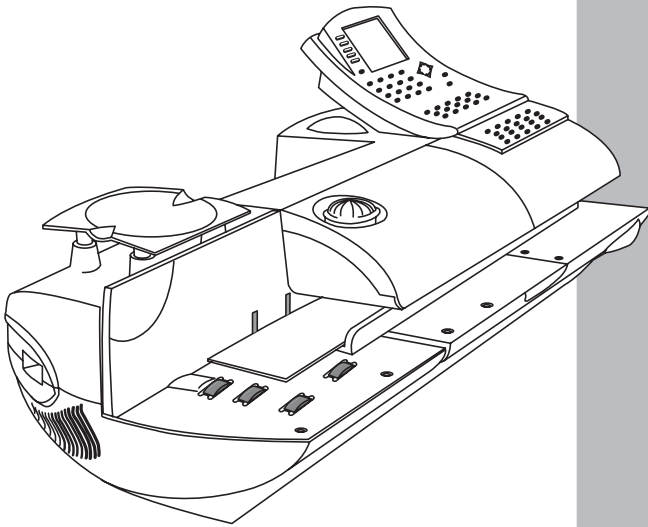

## 9 Maintaining and Updating

### Contents

<i>Items to Keep On Hand</i> .....	9-2
<i>Cleaning the Exterior</i> .....	9-2
<i>Tape Maintenance</i> .....	9-3
<i>E-Z Seal® Sealing Solution Maintenance</i> .....	9-5
<i>Moistener Maintenance</i> .....	9-6
<i>Printer Maintenance</i> .....	9-13
<i>Replacing the Ink Cartridge</i> .....	9-15
<i>Changing the Printhead</i> .....	9-18
<i>Changing the Wiper Blade Assembly</i> .....	9-22
<i>Performing Updates or Adding Features</i> .....	9-23

## 9 • Maintaining and Updating

---

### Items to Keep On Hand

The following is a list of items you should keep on hand:

- Ink Cartridge
- Tape Roll
- E-Z Seal® Sealing Solution

Refer to *Chapter 11, Supplies and Options* for details on how to order these items.

### Cleaning the Exterior

To clean the outside of your mailing system, wipe it off with a soft dry cloth. Do not use harsh chemical cleaners. If necessary, use only Windex® or soapy water.

You may clean the display screen on the IntelliLink® Control Center with a mild glass cleaner and soft cloth.



**CAUTION:** Do not pour or spray cleaner directly on the display screen or machine. Spray on the cloth and wipe the screen with the dampened cloth.

---

## Tape Maintenance

Tape maintenance consists of installing a new tape roll.

The DM500™ and DM550™ systems uses adhesive tape. A red stripe appears along its edge approximately 22 inches from the end to indicate a low tape condition. Replace the tape when the stripe appears. To order new tape, refer to *Chapter 11, Supplies and Options* in this guide.



**CAUTION:** If you do not use Pitney Bowes supplied tape, you will not be able to determine when the tape is running out and this may cause a jam.

The red stripe on the tape notifies you that you are running low on tape. There is also a black stripe that tells the machine when it is out of tape. When the system detects the black stripe on the tape it stops the machine. At this point there is still a small amount of tape on the roll.

---

If you install a new roll before the system actually runs out of tape, go to *Tape is still on roll* below. If the system runs out of tape and the message “Out of Tape” appears on the display, go to *Tape has run out* in this section.

### ***Tape is still on roll***

1. When you see the red stripe on the tape, go to the Tape Maintenance screen:
  - a.) Press the **Menu** key.
  - b.) Select **Maintenance**.
  - c.) Select **Load Tape**.
  - d.) Select **Unload Tape**.

Open the feed cover and remove the tape roll. The interior of the DM500™ (and DM550™) system is shown in the figure below.

Feed Cover Open

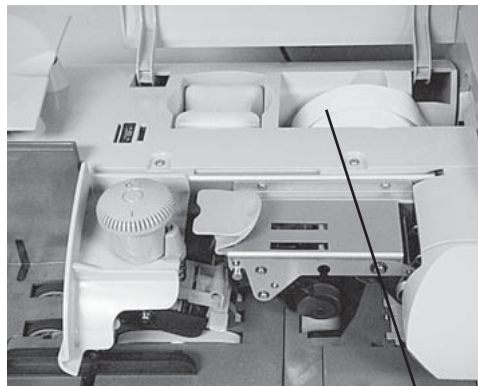

Tape Roll

### ***Tape still on Roll***

continued

2. Drop the new tape in so that it feeds from the bottom of the roll to the right.

The protective backing on the tape should be facing down.

Pull about 12 inches of tape from the end of the roll up toward the cover and then loop it down into the slot.

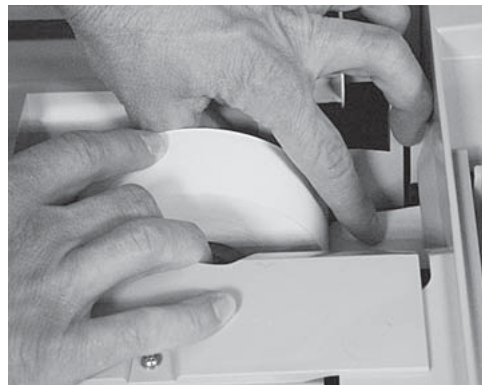

**CAUTION:** Do not load a tape strip that has any pink or black stripes showing. This will cause the last piece of tape to jam in the machine which and you will need to place a service call.

---

3. From the “Out of Tape” or “Load Tape” screen, select **Load Tape**. Feed the tape into the slot while the tape motor is running. The machine automatically cuts off the excess tape.
4. Close the feed cover.

### ***Tape has run out***

1. If the system actually runs out of tape, the “Out of Tape” screen appears.
2. Open the cover and select Unload Tape from the “Out of Tape” screen.
3. Remove any remaining tape on the tape roll. Follow steps 2 - 4 in the *Tape still on roll* procedure above.



## E-Z Seal® Sealing Solution Maintenance

Your mailing system displays a message telling you when your E-Z Seal® Solution is running low. When you receive this message, your system can still seal approximately 50 envelopes.



**CAUTION:** Pitney Bowes recommends using E-Z Seal® Solution because it helps keep your moistener tank clean and improves sealing efficiency. To order E-Z Seal® Solution, refer to *Chapter 11, Supplies and Options* in this guide.

---

1. Open the feed cover and lift out the E-Z Seal® bottle.  
The bottle is located to the left of the tape roll.



E-Z Seal® Bottle

2. Remove the cap from the bottle.
3. Add enough E-Z Seal® to bring the level up to the bottom of the fill cap.



**CAUTION:** Do not overfill the E-Z Seal® Bottle

**CAUTION:** Make sure you do not spill any solution in the tape well. If the tape gets wet, it can warp and cause a jam.

---

4. Replace and tighten the cap and replace the bottle. The nozzle should be facing down and the flat side of the bottle facing the front of the system.
  5. Close the feed cover.
-

### Moistener Maintenance

This section describes how to clean and/or replace the part of your mailing system that moistens the flap on the envelope. This part of the mailing system is the moistener brush assembly and consists of the moistener brush, moistener wick and moistener tank.

If the seal quality does not improve after cleaning, you can replace the wick or moistener brush as needed. To order replacements, refer to *Chapter 11, Supplies and Options* in this guide. Only a Pitney Bowes representative can install a new moistener tank.



**CAUTION:** Never remove the E-Z Seal® bottle and the moistener tank at the same time. This can result in E-Z Seal® leaking into the mailing machine.

---

### Cleaning or Replacing the Moistener Brush

1. Lift the feed cover.
2. Push down on the moistener brush button.
3. Grasp the moistener brush assembly and pull it straight out towards you.
4. Clean the moistening brush by running the brush under warm water.
5. If you need to clean or replace the wick, go to *Cleaning or Replacing the Wick* procedure below. Otherwise go to step 6.

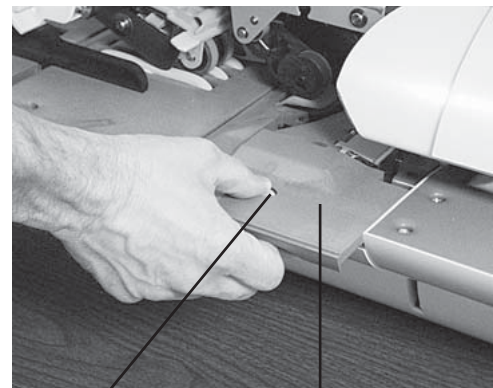

Moistener Brush Button

Moistener Brush Assembly

6. Replace the existing clean moistener brush assembly, or install a new one by pushing the assembly back on its track until it snaps into position.
7. Check to make sure that the flap blade of the moistener brush assembly is under (and not over) the stripper finger as shown here.

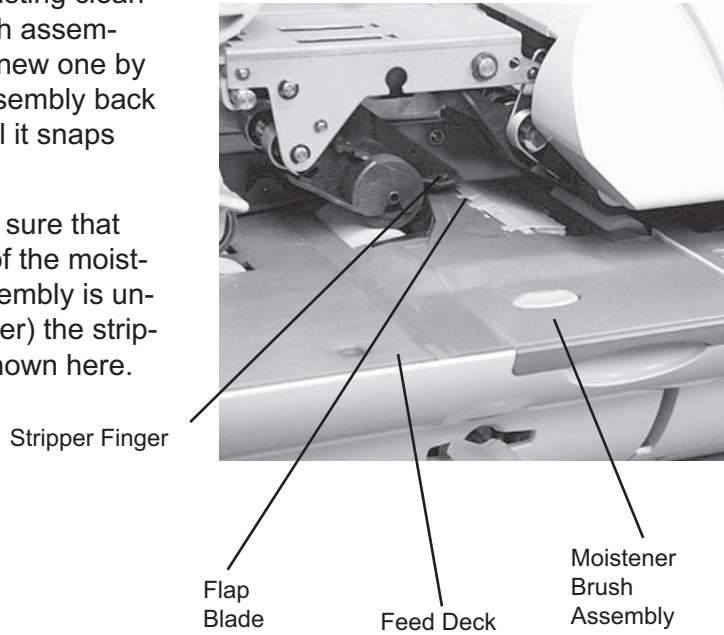

8. Verify that the moistener brush assembly is perfectly level with the feed deck

## 9 • Maintaining and Updating

---

### **Cleaning or Replacing the Wick**

1. Open the feed cover and lift the E-Z Seal® bottle out of its holder.
2. Remove the Moistener Brush Assembly as described above in *Cleaning or Replacing the Moistener Brush* procedure.
3. Place your finger in the moistener tank round guide and pull straight out towards you.

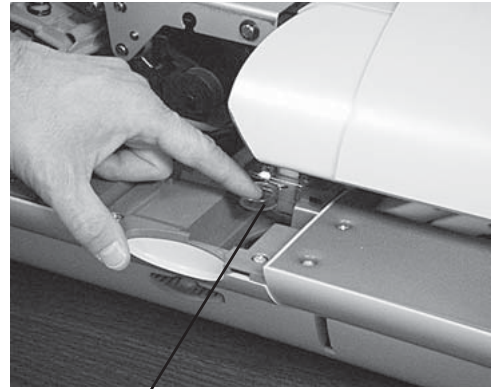

Moistener Tank Round Guide

4. Gently lift the moistener tank up and out.



**CAUTION:** The tank may be full of E-Z Seal® liquid.

---

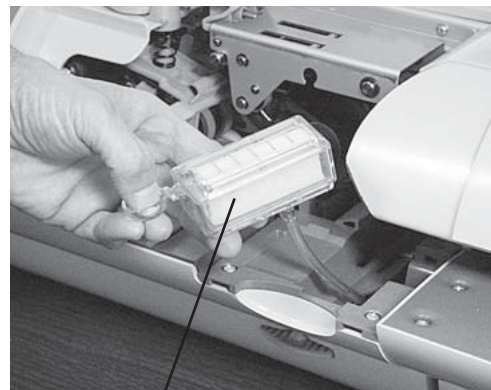

Moistener Tank

5. Remove the wick, using the metal shield to gently pry it out of the moistener tank.



Wick Shield

**Cleaning or Replacing the Wick**

continued

6. Drain the moistener tank over the front of the machine into a receptacle as shown here.

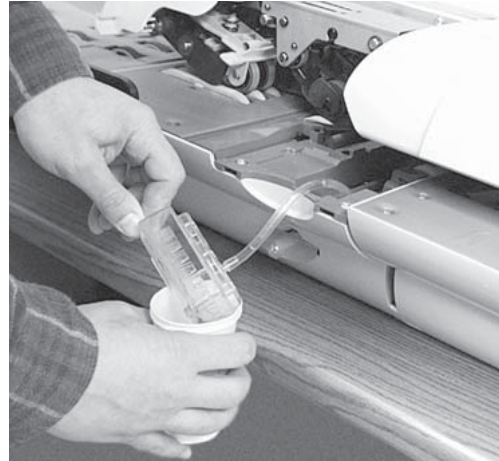

7. To clean the moistener tank, remove the E-Z Seal® Sealing Solution supply tube and wipe out the tank with E-Z Seal® solution.

Clean the wick by holding it under running water.

8. Push the supply tube back onto the moistener tank nozzle. Push the tube back on as far as it will go to prevent leaking.



9. After cleaning the wick and tank, place the shield on the wick, making sure that there is no gap between the shield and the surface of the wick.





## 9 • Maintaining and Updating

---

### **Cleaning or Replacing the Wick**

continued

10. Place the shield and wick assembly in the moistener tank and push down on the shield to push the assembly into the tank.



11. Replace the moistener tank and gently slide it back into the machine, taking care not to crimp the supply tubing. Do not push the tank all the way back into the machine yet.

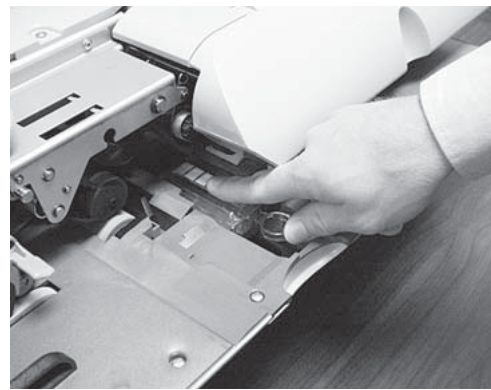

12. Replace the E-Z Seal® Sealing Solution bottle. Wait for about 5 minutes and then check to make sure the moistener tank is filled with the correct amount of E-Z Seal® solution. Measure the amount of solution as shown in the diagram on the right. The solution level should be: 14 - 18 mm (0.55 - 0.71 in.)

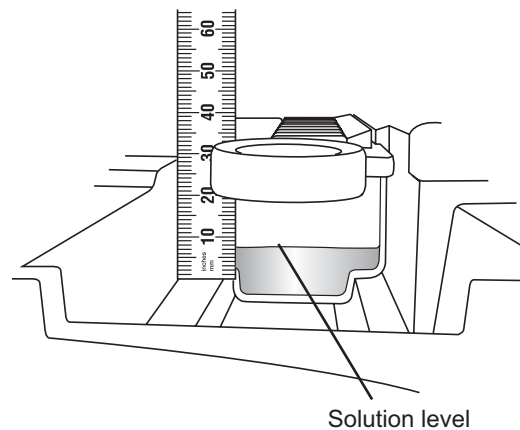

If, after 5 minutes, the moistener tank is not filled to the correct level, remove the E-Z Seal® bottle, wait 20 seconds and then replace it again.

If after another 5 minutes the level is still not correct, go to step 13. Otherwise go to step 14.

## **Cleaning or Replacing the Wick**

continued

13. Remove the moistener tank and hold it as high as you can above the machine as shown in the picture on the right.

Hold it in this position for approximately 20 seconds.

- a. Replace the moistener tank again and gently slide it back into the machine, taking care not to crimp the supply tubing. Do not push the tank all the way back into the machine yet.
- b. Wait about 5 minutes and then check the level of E-Z Seal® Sealing Solution again as described in step 12 above.

- c. If the tank is still not filled to the correct level, remove the moistener tank and drain it over the front of the machine, then replace the tank and check the level again after 5 minutes.

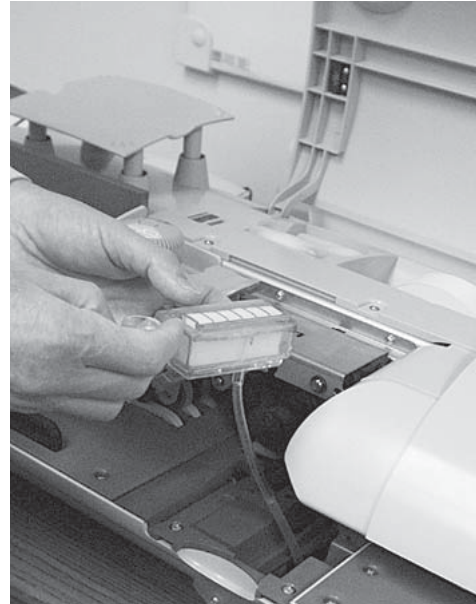

14. Once you verify that the moistener tank is filled to the correct level with E-Z Seal® Solution, gently push the tank all the way back to its original position.

## 9 • Maintaining and Updating

---

15. Replace the moistener brush assembly by pushing it back on its track until it snaps into position.

Check to make sure that the flap blade of the moistener brush assembly is under (and not over) the stripper finger as shown here.

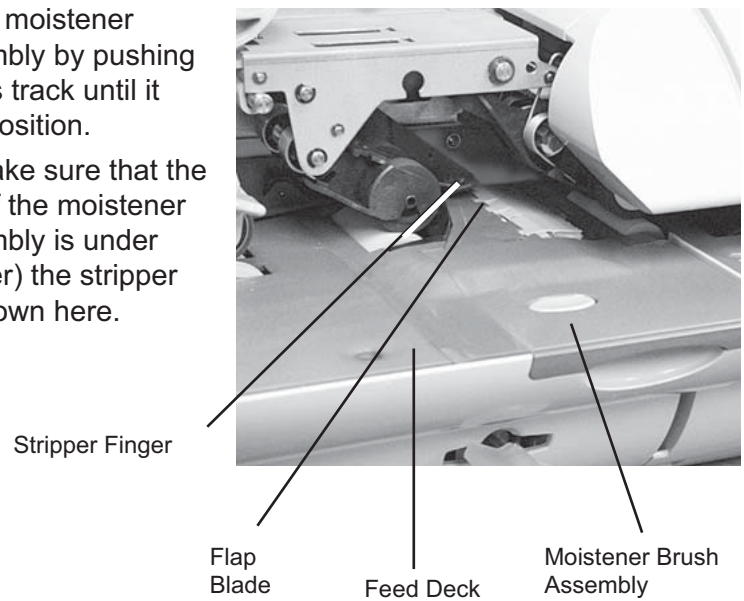

16. Verify that the moistener brush assembly is perfectly level with the feed deck.
17. Close the feed cover.



## Printer Maintenance

The printer components, consisting of the printer nozzle, ink cartridge and printhead, require minimum maintenance to ensure clean, clear meter imprints on your mail.

If the print quality deteriorates and you cannot improve it with the procedures in this chapter, contact the Pitney Bowes Help Desk. Refer to the *Pitney Bowes Contact Information List* at the front of this guide for the phone number.

## Printing a Test Pattern

You can print a test pattern to check the quality of the meter imprint without spending any of your postage funds.

To print a test pattern:

1. From the IntelliLink® Control Center, press the **Menu** key.
2. Select **Maintenance**.
3. Select **Print Test Pattern**.
4. The “Print Test Pattern” screen appears and prompts you to “Press Tape or print an envelope”.
5. Load an envelope on the feed deck and press **Start**, or press **Tape** to print on a tape.
6. Once the test pattern prints, the system asks you if the test pattern printed correctly.

If the test pattern looks like the sample shown here, press the **Yes, Lines are unbroken** screen key. Go to step 10.

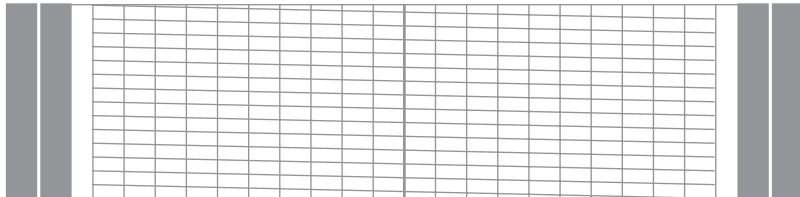

If the test pattern has missing or incomplete lines as shown here, press the **No, clean the print nozzle** screen key. Go to step 7.

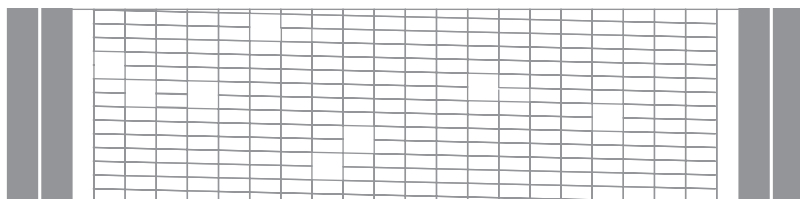

7. The “Cleaning Print Nozzle” screen displays until the cleaning operation completes.

### **Printing a Test Pattern**

continued

8. Once the cleaning operation completes, the “Print Test Pattern” screen appears again.
9. Repeat steps 5 and 6 again. If the print pattern still has broken or missing lines, you may need to replace the ink cartridge (see *Replacing the Ink Cartridge*) or printhead (see *Changing the Printhead*).  
If the test pattern is ok, go to step 10.
10. Press the left arrow key to return to the postage screen.

### **Cleaning the Printer Nozzle**

You can clean the printer nozzle at any time by following these steps:

1. From the IntelliLink® Control Center, press the **Menu** key.
2. Select **Maintenance**.
3. Select **Clean Printer Nozzle**. The “Cleaning Print Nozzle” screen displays until the cleaning operation completes.
4. Once the cleaning operation completes, the “Print Test Pattern” screen appears.
5. Print a test pattern as described above in Printing a Test Pattern to verify that you can print a clean and clear meter stamp.
6. Repeat this operation at least one more time.

## Replacing the Ink Cartridge

“Low Ink - Order Ink” appears on the IntelliLink® Control Center main screen when there is only enough ink for approximately 10 days of mailing. You can choose to ignore this warning - refer to the *Configuring Low Ink Warning* section in *Chapter 5* in this guide.

Your actual ink usage will vary depending on whether you routinely print advertisements or inscriptions and how many pieces of mail you print per day.

“Low Ink” displays approximately two days before the ink runs out. You can print about another 300 meter stamps or leave the mailing system running for six days without printing. If you do not have a replacement cartridge, order one now. Refer to *Supplies and Options, Chapter 11* in this guide.

“Out of Ink” displays when there is no more ink left in the cartridge and your mailing system stops printing. In order to resume printing you must change the ink cartridge.



**WARNING!** You must use only ink cartridges supplied by Pitney Bowes. The use of any other ink cartridges will void your warranty and maintenance agreement.

**WARNING!** The ink in the cartridge may be harmful if swallowed. Keep new and used cartridges out of reach of children. Discard empty cartridges immediately.

**WARNING!** Do not remove the ink cartridge if the printhead is not installed. If the ink cartridge and printhead are removed at the same time, ink from the print supply line will flow down the tube and squirt from the needle in the ink cartridge holder out into the printer and system interior.

**WARNING!** Make sure there is enough room to fully lift the main cover without bumping the IntelliLink® Control Center.

---

## 9 • Maintaining and Updating

---

To replace the ink cartridge:

1. Lift up the main cover and locate the ink cartridge lid.

Ink Cartridge Lid

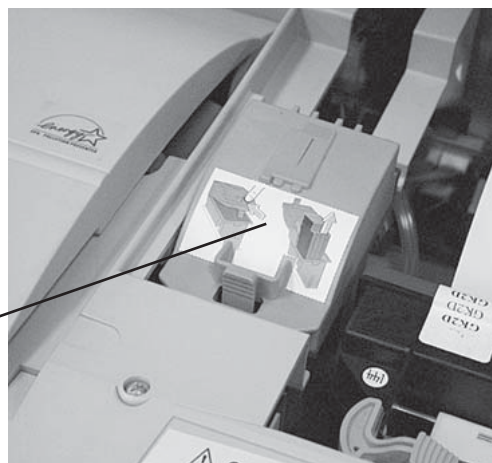

2. Push the tab on the front of the cartridge lid. Lift the lid up and push toward the back of the machine.

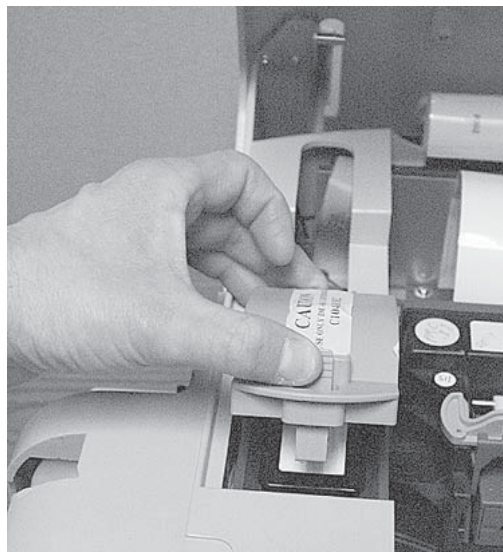

3. Remove the old ink cartridge by lifting it straight up.

Ink Cartridge

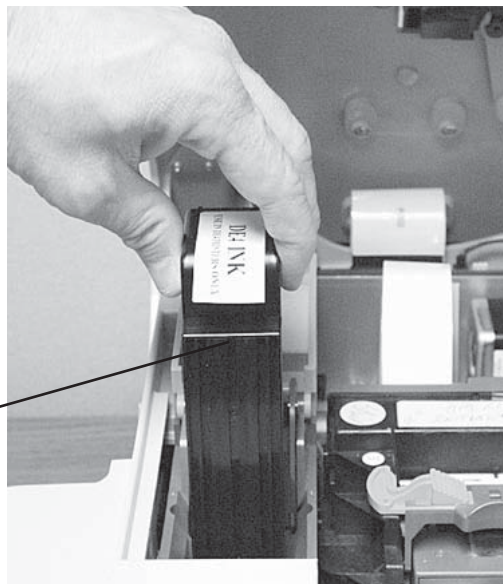

## Replacing the Ink Cartridge

continued

4. Insert the new ink cartridge with the grooved side facing you.
5. Close the ink cartridge lid and push down until it locks into place.
6. Close the main cover.
7. Print a test pattern to verify that you have installed the ink cartridge correctly (see *Printing a Test Pattern* in this chapter).



### Changing the Printhead

If you have cleaned the printer nozzle and changed the print cartridge and the meter stamp is still not satisfactory, replace the printhead.

---



**CAUTION:** Do NOT attempt to clean the printhead.

---

Instructions for replacing the printhead are included with each replacement and are repeated here for your convenience.

1. Press the **Menu** key.
2. Select **Maintenance**.
3. Select **Replace Printhead**. The “Printhead Warning - Continue?” screen appears. Read this screen carefully since once you agree to continue, you cannot cancel the process.
4. Once you verify that you have a replacement printhead, select **Yes**, continue from the screen. The “Replace Printhead” screen appears.

5. Open the main cover and locate the printhead tab.

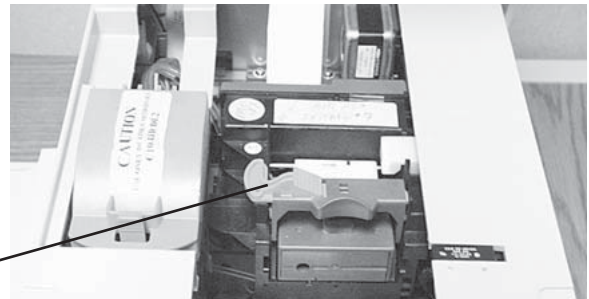

Printhead Tab

**Changing the Printhead**

continued

6. Push the printhead tab to the left as shown here.

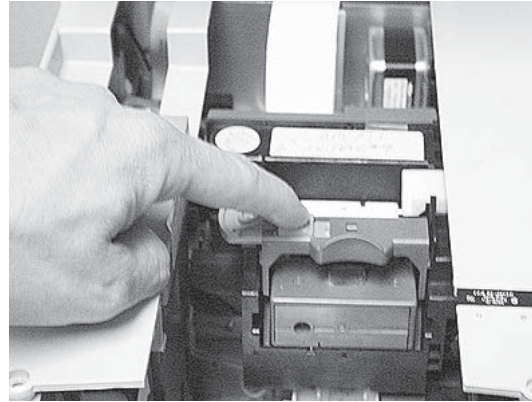

7. While continuing to press the printhead tab to the left, pull the assembly forward as shown here. This exposes the printhead cover.

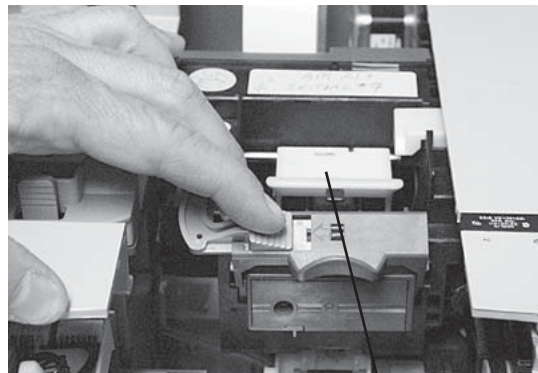

Printhead cover

8. Grasp the printhead cover and pull up as shown here.

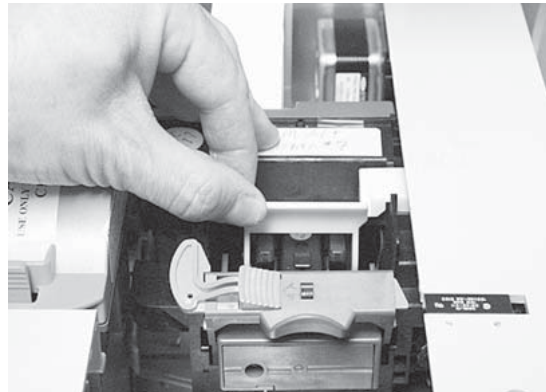



### Changing the Printhead

continued

9. Locate the stand-off on top of the printhead shown here.

Printhead Stand-off

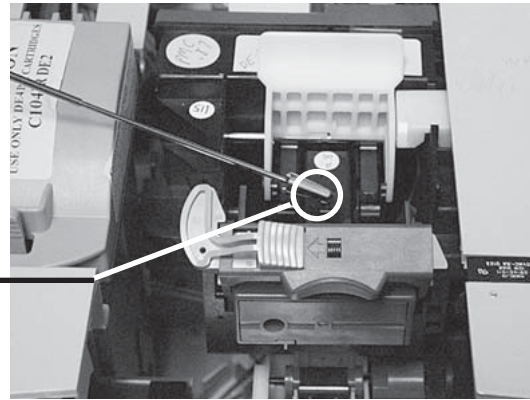

10. Grasp the printhead stand-off and lift the printhead up and out.
11. Discard the old printhead.

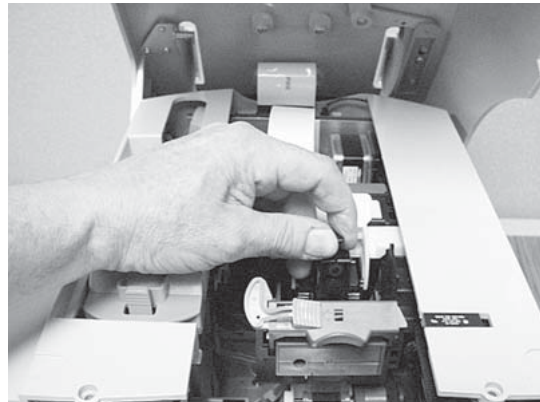

12. Locate the new printhead. Remove the orange packing tab from the new printhead as shown here.
13. Install the new printhead in the printhead slot.





## **Changing the Printhead**

continued

14. Close the printhead cover and push the printhead tab back into place.
15. Close the main cover; the “Initializing Printhead” screen appears.
16. Once the initializing is complete, the “Print Test Pattern” screen appears and prompts you to “Press Tape or print an envelope”.  
You must perform the print test at this time. Follow the prompts, or refer to *Printing a Test Pattern* in this chapter for more information.
17. Proceed to *Changing the Wiper Blade Assembly*.

### Changing the Wiper Blade Assembly

When you change the printhead, you must also replace the wiper blade assembly.

Instructions for replacing the wiper blade assembly are included with each replacement and are repeated here for your convenience.

1. From the IntelliLink® Control Center, press the **Menu** key.
2. Select **Maintenance**.
3. Select **Replace Wiper Blade Assembly**.

The “Preparing Wiper Blade” screen appears. During this time, the system moves the printhead assembly back so that you can access the wiper blade assembly.

4. The “Replace Wiper Blade Assembly” screen appears instructing you to remove the wiper blade assembly from the package.

5. Lift the main cover and locate the wiper blade assembly.

6. Push the wiper blade tab toward the back of the machine. This causes the wiper blade to slide to the left.

7. Lift the wiper blade up and out of the assembly and discard.

8. Place the new wiper blade in the assembly with the two white prongs facing to the right. Slide it to the right until it snaps into place.

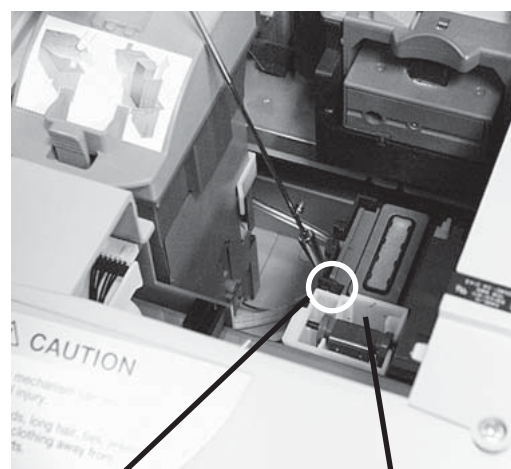

Wiper Blade Tab

Wiper Blade Assembly

9. Close the main cover; the “Initializing Wiper Blade” screen appears.
10. Once the initializing is complete, the “Print Test Pattern” screen appears and prompts you to “Press Tape or print an envelope”.

You must perform the print test at this time. Follow the prompts, or refer to *Printing a Test Pattern* in this chapter for more information.

## Performing Updates or Adding Features

This section describes how to:

- Turn on new features.
- Perform software updates and download new postal rates.
- Add new advertisements and inscriptions.

### ***Turn on New Features***

If you purchase a particular feature before your system is delivered, your Pitney Bowes representative will enter the feature code when installing your system. If you purchase the feature after your system is installed, you will be given the feature code when you purchase the feature.

1. Press the **Menu** key on the IntelliLink® Control Center and select **Turn Features On**.
2. The system prompts you to enter the numeric code of the feature you want to enable.
3. Type in the code and press the **Enter** key. The system notifies you that the feature is now turned on.

### ***Perform Software Updates***

1. Press the **Menu** key.
2. Select **Set Up** and then press the down arrow key.
3. Select **Updates and Add-Ons**.
4. Select **Check for Updates**. The system connects to Pitney Bowes and requests a list of updates.
5. If no updates are available, click **OK** to exit this screen.
6. If updates are available, select the appropriate update and follow the prompts displayed on the screen.

### ***Add new Advertisements or Inscriptions***

1. Press the **Menu** key.
2. Select **Set Up** and then press the down arrow key.
3. Select **Updates and Add-Ons**.
4. Select either **Advertisements** or **Inscriptions** depending on which one is appropriate.
5. If your system provides more than one way of adding or updating features, your system may prompt you to "Select Method of Update". If you see this prompt go to step 6, otherwise follow the prompts.

### Performing Updates or Adding Features

continued

6. Select the method of update from the options displayed on the screen. The options are:

Art Card

Feature Code

Phone Download

- a. **Art Card:**

If you select **Art Card**, the system prompts you to “Place Art Card in slot at side of control panel”. Insert the art card containing the update or add-on and the system begins the download. As soon as it completes you are prompted to restart your system so that the updates can take effect.

- b. **Feature Code:**

If you select **Feature Code**, you are prompted to enter the numeric value of the feature you want to enable. Type in the code for the feature and press the **Enter** key. The system then notifies you that the feature is now turned on.

To get a list of all the current features enabled on your system, select the **Feature Code**, then press the right arrow key and a list of the features appears.

- c. **Phone Download:**

If you select **Phone Download**, your system dials Pitney Bowes and performs the update or add-on as soon as it establishes a connection. As soon as it completes the add-on, it prompts you to restart your system so that the updates can take effect.

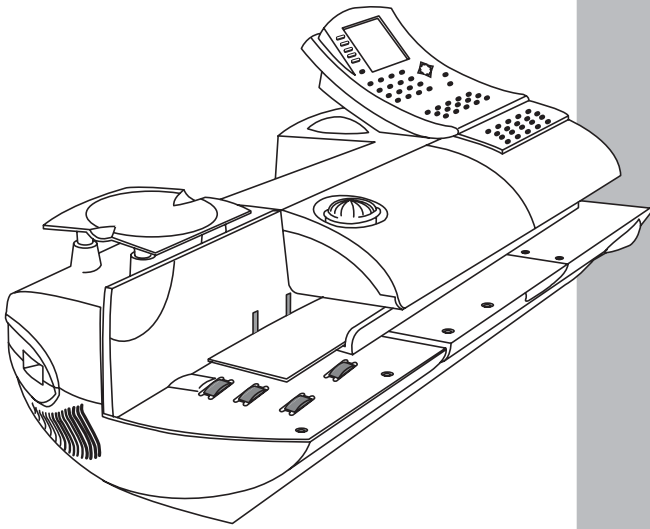

## 10 Troubleshooting

### Contents

<i>How to Troubleshoot your DM500™ and DM550™ Digital Mailing System .....</i>	<i>10-2</i>
<i>Envelope Sealing Problems .....</i>	<i>10-2</i>
<i>Envelope Feeding Problems .....</i>	<i>10-3</i>
<i>Tape Feeding Problems .....</i>	<i>10-6</i>
<i>Printing Problems .....</i>	<i>10-6</i>
<i>Problems Adding Postage to Your Meter .....</i>	<i>10-8</i>
<i>Display Problems .....</i>	<i>10-8</i>
<i>Weighing Problems .....</i>	<i>10-9</i>



## 10 • Troubleshooting

### How to Troubleshoot your DM Series™ Digital Mailing System

This chapter contains a list of problems you may encounter while using your DM Series™ System.

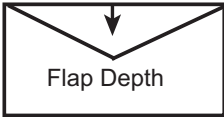
Review the problems and if you are unable to find a solution, call the Help Desk or you can schedule a request for service at our web site. Refer to the *Pitney Bowes Contact Information List* at the front of this guide for the phone number of the Help Desk and the web site addresses.

Envelope Sealing Problems		
Description	Possible Causes	Solution
Envelope(s) not sealing or not sealing properly	No E-Z Seal® Sealing Solution in the bottle, or bottle is placed incorrectly.	Remove the E-Z Seal® solution bottle and refill or reposition the bottle. Refer to the <i>E-Z Seal® Maintenance</i> section in <i>Chapter 9</i> of this guide.
	Moistener brush is dirty or worn.	Replace or clean the moistener brush. Refer to the <i>Cleaning or Replacing the Moistener Brush</i> section in <i>Chapter 9</i> of this guide.
	Envelopes are not positioned on the feed deck correctly, or side guide is out too far.	Place envelopes with the flap down on the feed deck against the rear wall as shown here. Push the side guide close to the envelope or stack of envelopes but not to the point where it is touching the envelopes. Leave about 1/16" clearance (the thickness of a dime).   Side guide
	Envelope flap dimensions are not within the acceptable range.	Use envelopes with flap depths between 1" and 3" (25.4 mm and 76.2 mm).  

<b>Envelope Feeding Problems</b>		
<b>Description</b>	<b>Possible Causes</b>	<b>Solution</b>
More than one envelope is feeding	Too many envelopes are on the feed deck; envelopes are not stacked properly on the feed deck.	<p>Remove some of the envelope and test with a smaller stack. Slant the envelopes slightly to the left (shingled).</p>  <p>Shingled</p>
	Feeder adjustment setting is incorrect.	<p>Adjust the thickness adjustment knob to correspond to the envelope thickness. For thicker pieces of mail (3/8" to 5/8"), or mail containing several inserts, use the thick mail setting. For mail containing only single inserts, or for postcards, use the normal mail setting.</p>  <p>Thick Mail Setting</p> <p>Normal Mail Setting</p>

## 10 • Troubleshooting

Envelope Feeding Problems		
Description	Possible Causes	Solution
Envelope(s) getting jammed	Envelopes are too thick or thin for the feeder adjustment setting.	<p>Adjust the thickness adjustment knob to correspond to the envelope thickness. For thicker pieces of mail (3/8" to 5/8"), or mail containing several inserts, use the thick mail setting. For mail containing only single inserts, or for postcards, use the normal mail setting.</p> <div style="display: flex; align-items: center; justify-content: center;"> <div style="margin-right: 20px;">Thick Mail Setting</div>  </div>
	Trying to feed presealed envelopes with the seal mode set to Sealer On.	Press the <b>Seal</b> key from the control panel and select <b>Sealer Off</b> .
	You are using envelopes that have dimensions that are outside the acceptable ranges.	<p>Refer to the <i>Specifications</i> section in <i>Chapter 2</i> of this guide for the acceptable envelope dimensions.</p> <p><b>To clear a jam in the feed deck:</b></p> <ol style="list-style-type: none"> <li>1. Lift the feeder cover.</li> <li>2. Pull up on the top release jam lever.</li> <li>3. Lift up the lower release lever.</li> <li>4. Release the envelope as shown in the figure below:</li> </ol>

Top Release Jam Lever

Lower Release Lever





Envelope Feeding Problems		
Description	Possible Causes	Solution
Envelope(s) getting jammed (continued)		<p><b>To clear a jam in the feed deck :</b> (continued)</p> <ol style="list-style-type: none"> <li>5. Depending on how badly the envelope is damaged, you may need to replace it.</li> <li>6. Make sure the feed deck is clear and the jam release levers are down.</li> <li>7. To continue processing mail, close the cover and select <b>Start to continue</b> from the display.</li> </ol> <p><b>To clear a jam in the transport deck:</b></p> <ol style="list-style-type: none"> <li>1. Pull out on the transport release knob.</li> <li>2. Remove the envelope.</li> <li>3. If the jam occurred before the system applied postage to the envelope, the system will now print the postage on a tape. Apply the postage tape to the envelope.</li> <li>4. Push the transport deck back up until it snaps into position.</li> <li>5. Make sure the transport deck is level with the feed deck.</li> <li>6. Run a test pattern to make sure the printhead is not damaged. Refer to <i>Printing a Test Pattern</i> in Chapter 9 in this guide.</li> </ol>

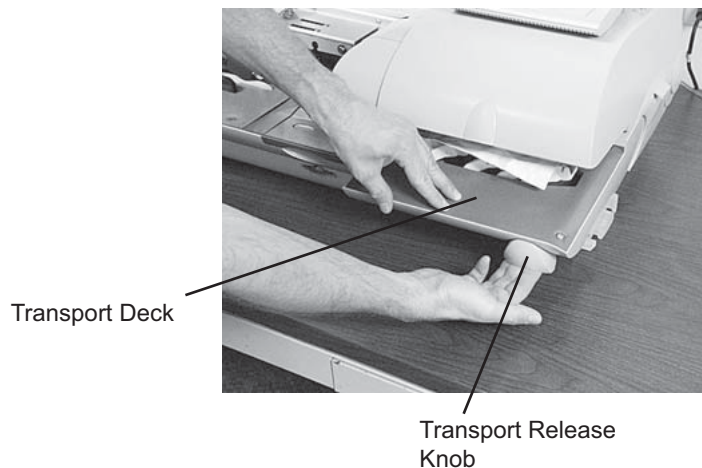

## 10 • Troubleshooting

Tape Feeding Problems		
Description	Possible Causes	Solution
Tape jamming in the feeder	Adhesive is left on the leading edge of the new tap roll, or the leading edge of the tape is rolled or folded under the tape roller.	<ol style="list-style-type: none"> <li>1. Lift the feed cover.</li> <li>2. Select <b>Unload Tape</b> from the screen.</li> <li>3. The system backs the tape out of the tape slot. If the system fails to back the tape out of the slot, gently pull the tape out of the slot.</li> <li>4. Cut off the portion of the tape that is rolled over or crimped. Make sure the leading edge of the tape is completely covered with the protective backing and that you have a clean straight cut.</li> <li>5. Put the tape back in so that it feeds from the bottom of the roll to the right. The protective backing on the tape should be facing down. Pull about 12 inches of tape from the end of the roll up toward the cover and then loop it down into the slot. Feed the tape back into the tape slot.</li> <li>6. From the "Out of Tape" screen, select the <b>Press Tape to feed tape</b> screen key to feed the tape through the machine. The machine automatically cuts off the excess tape.</li> <li>7. Close the feed cover.</li> <li>8. If this problem persists, call the Help Desk. Refer to the <i>Pitney Bowes Contact Information List</i> in this guide.</li> </ol>
Printing Problems		
No postage is printing	The Postage Mode is set to Seal Only.	From the IntelliLink® Control Center, press the <b>Mode</b> key and select the appropriate postage mode option displayed on the screen. Refer to <i>Selecting the Postage Mode</i> in <i>Chapter 4</i> in this guide.
	Postal inspection is required. Your mailing system performs an automatic postal inspection every time you do a refill. If you have not done a refill in the last 120 days, you will not be able to print postage.	Add postage. If you do not need to add postage at this time, simply log onto the Pitney Bowes Data Center and check for updates. The system will automatically perform a meter inspection.
	Your postal rate or special service requires a ZIP or Zone Code.	Enter the ZIP or Zone Code. Refer to <i>Selecting ZIP Codes and Zones</i> in <i>Chapter 4</i> of this guide.

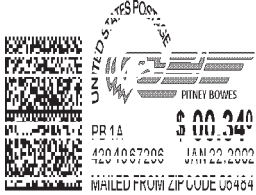
Printing Problems		
Description	Possible Causes	Solution
Meter imprint is out of alignment	Envelope is skewing on the feed deck.	<p>Adjust the thickness adjustment knob to correspond to the envelope thickness. For thicker pieces of mail (3/8" to 5/8"), or mail containing several inserts, use the thick mail setting. For mail containing only single inserts, or for postcards, use the normal mail setting.</p> <div style="display: flex; align-items: center; justify-content: center;"> <div style="margin-right: 20px;">Thick Mail Setting</div>  </div> <p>Position the side guide close to, but not touching the envelope.</p>
<p>Meter imprint is streaked or incomplete; poor print quality:</p> 	The printer nozzle requires maintenance.	<p>Clean the printer nozzle and run a test print as described in <i>Cleaning the Printer Nozzle</i> section in <i>Chapter 9</i> in this guide.</p>
	You need to change the printhead and wiper blade assembly.	<p>If you have already cleaned the printer nozzle and this fails to correct the problem, you need to change the printhead and wiper blade assembly.</p> <p>Refer to <i>Changing the Printhead</i> and <i>Changing the Wiper Blade Assembly</i> sections in <i>Chapter 9</i> in this guide.</p> <p>If this fails to correct the problem, call the Help Desk. Refer to the <i>Pitney Bowes Contact Information List</i> in this guide.</p>

## 10 • Troubleshooting

Problems Adding Postage to Your Postage Meter		
Description	Possible Causes	Solution
Refill operation fails when IntelliLink® Control Center is on or off the mailing system	Phone line is not connected to an analog line or is loose.	Reconnect the phone line to the back of the IntelliLink® Control Center.
	Phone cord is damaged.	Check phone cord for damage (cuts or crimps) and replace if necessary.
	Problem with the phone line.	Test the main phone outlet and repair if necessary.
	You are using the wrong Postage By Phone® Meter Payment System telephone number.	Contact the Help Desk for correct number. Refer to the <i>Pitney Bowes Contact Information List</i> in this guide for the phone number of the Help Desk.  The Help Desk may also provide you with a local number to use for Postage By Phone® System.  To change the Postage By Phone® System number, refer to <i>Phone/Network Set Up: PB Phone #</i> section in <i>Chapter 5</i> of this guide.
Refill amount exceeds the funds in your account.	Check your account balance. Refer to the section <i>Checking Your Postage By Phone® Meter Payment System Account</i> in <i>Chapter 6</i> of this guide.	
Display Problems		
Display is blank after moving the IntelliLink® Control Panel	There is no power to the IntelliLink® Control Center.	<ol style="list-style-type: none"> <li>1. Make sure the AC adapter is plugged into the back of the control center.</li> <li>2. Test the outlet to make sure it has power.</li> <li>3. If the problem persists, call the Help Desk. Refer to the <i>Pitney Bowes Contact Information List</i> in this guide.</li> </ol>
Unable to access display, or keyboard does not respond.	This may be a system error.	Call the Help Desk. Refer to the <i>Pitney Bowes Contact Information List</i> in this guide for the phone number.
Difficult to read the display	You need to adjust the display contrast.	Adjust the display contrast; refer to <i>Adjusting the Display Contrast and Volume Control</i> section in <i>Chapter 5</i> in this guide.  If the problem persists, call the Help Desk. Refer to the <i>Pitney Bowes Contact Information List</i> in this guide.

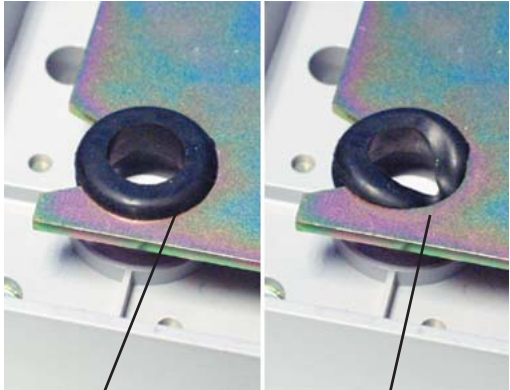
<b>Weighing Problems</b>		
<b>Description</b>	<b>Possible Causes</b>	<b>Solution</b>
Weight on internal scale is erratic	Possible interference.	<p>Remove everything from the scale and turn off the power. Rezero the scale. To rezero the scale, press the <b>Menu</b> key, then select <b>Zero Scale</b>.</p> <p>Make sure when you place mail on the scale you center it and check to make sure that it is not touching another surface.</p>
Weights on external scale are erratic or the scale does not return to zero	<p>For MP Series External Weighing Platform scales: The scale top cover may not be seated properly on the scale</p>	<ol style="list-style-type: none"> <li>1. Remove the top cover and make sure the 4 plastic grommets in the scale are seated properly. The 4 plastic posts on the top cover fit into these grommets.</li> <li>2. If a grommet, or any part of a grommet, is pushed below the surface of the metal on the scale, reseal it until it appears as shown here: <div style="text-align: center;">  <div style="display: flex; justify-content: space-around; margin-top: 5px;"> <div style="text-align: center;"> <p>Grommet seated properly</p> </div> <div style="text-align: center;"> <p>Grommet pushed below the surface</p> </div> </div> </div></li> <li>3. Check to make sure the bubble is centered in the circle as shown on the next page. If not, and you have a flatblade screwdriver, center the bubble by adjusting the legs, otherwise go to step 4.</li> </ol>

Weighing Problems		
Description	Possible Causes	Solution
<p>Weights on external scale are erratic or the scale does not return to zero. continued</p>	<p>For MP Series External Weighing Platform scales: The scale top cover may not be seated properly on the scale</p>	<div data-bbox="915 363 1398 739" data-label="Image"> </div> <p style="text-align: center;">Center the bubble</p> <p>4. If you do not have a flathead screw driver, lift the corner and adjust the leg(s) until the bubble is centered in the circle.</p> <div data-bbox="915 982 1446 1386" data-label="Image"> </div> <p>5. Replace the top cover and test the scale.</p> <p><b>To test the scale:</b></p> <ol style="list-style-type: none"> <li>1. Place a piece of mail of known weight and correct postage on the scale.</li> <li>2. Press the <b>Mode</b> key.</li> <li>3. Select <b>Attached Scale</b>. "Attached Scale Mode" appears in the display</li> <li>4. Press the <b>Class</b> key and enter a class.</li> <li>5. Press the <b>Enter</b> key.</li> <li>6. Check to see that the correct postage amount appears on the screen.</li> </ol>

# 11 *Supplies and Options*

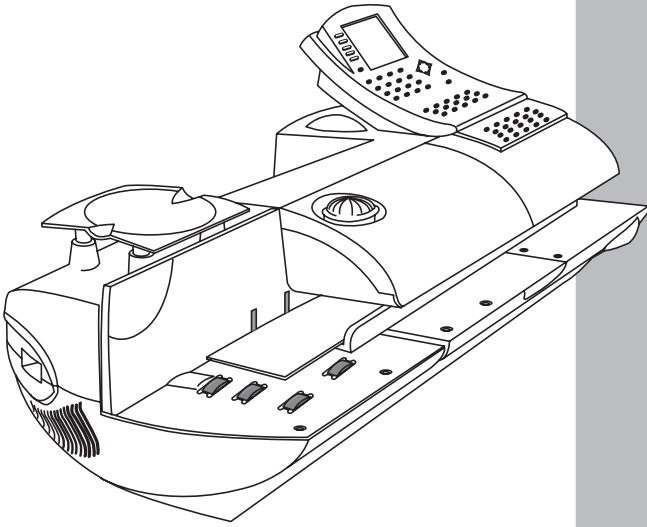

## *Contents*

<i>Ordering Supplies</i> .....	11-2
<i>Consumables You Can Order</i> .....	11-2
<i>Moistener Kit</i> .....	11-3
<i>Wiper Blade and Printhead Kits</i> .....	11-3
<i>Accessories You Can Order</i> .....	11-4
<i>USPS Supplies</i> .....	11-5

## 11 • Supplies and Options

---

### Ordering Supplies

You can order supplies through the Pitney Bowes Supply Line™, or you can order from the Pitney Bowes web site. Refer to the *Pitney Bowes Contact Information List* at the front of this guide for the Pitney Bowes Supply Line™ phone number and the web site addresses. The Pitney Bowes web site features a wide assortment of genuine Pitney Bowes supplies at attractive prices. You can take advantage of special quantity pricing and online discounts.

### Ordering a Pitney Bowes Supply Catalog

You can order a Pitney Bowes Supply Line™ Catalog. Refer to the *Pitney Bowes Contact Information List* at the front of this guide for the Pitney Bowes Supply Line™ phone number.

### Consumables You Can Order

#### Ink Cartridges\*

Red Ink Cartridges	621-1
--------------------	-------

\* Shelf life/installed life is 1.5 years



**WARNING!** You must use only ink cartridges supplied by Pitney Bowes. The use of any other ink cartridges will void your warranty and maintenance agreement.

#### Tape

4" Pressure - Box of 3 rolls	610-7
------------------------------	-------

5" Pressure - Box of 3 rolls	627-8
------------------------------	-------

#### Sealing Solution

E-Z Seal® Sealing Solution	
----------------------------	--

16 Ounce Bottles - 4	601-0
----------------------	-------



<b>Moistener Kit</b>	Moistener Kit	771-0
	(includes complete stripper blade assembly with brush in holder, wick and protective grate)	
<b>Wiper Blade and Printhead Kits</b>	DM Series™ Replacement Printhead	771-1
	(contains 1 printhead and 2 wiper blades per carton)	
	Replacement Wiper Blade	771-2
<b>USPS Confirmation Services</b>	Delivery Confirmation Labels	639-6
	Signature Confirmation Labels	639-9
	E-Certified Labels	639-5
	USPS Confirmation Services Request Book	640-7

## Accessories You Can Order

### Advertisements and Inscriptions

Advertisements and inscriptions contain messages you can include in the meter stamp. A number of standard advertisements and inscriptions are included with your mailing system.

You can order additional customized advertisements and inscriptions bearing your personalized message by calling the Pitney Bowes Supply Line™ or visiting the Pitney Bowes web site. Refer to the *Pitney Bowes Contact Information List* at the front of this guide for the Pitney Bowes Supply Line™ phone number and the web site addresses.

### Advertisements included with your DM500™ and DM550™ Digital Mailing System

Address Service Requested  
Return Service Requested  
Seasons Greetings  
United States Flag

Recycle  
Happy Thanksgiving  
Please Open Immediately  
Urgent

ADDRESS SERVICE  
REQUESTED

RETURN SERVICE  
REQUESTED



**PLEASE OPEN  
IMMEDIATELY**

### URGENT

### Inscriptions included with your DM500™ and DM550™ Digital Mailing System

Presorted Standard  
Non Profit Organization  
Standard  
Par Avion

Air Mail  
Printed Matter  
First Class  
Priority Mail  
Presorted

PRESORTED  
STANDARD

NON PROFIT  
ORGANIZATION

STANDARD

PAR AVION

AIR MAIL

PRINTED  
MATTER

FIRST CLASS

PRIORITY MAIL

PRESORTED

## Ordering Permits for Your Mailing System

This feature may be offered as a standard or optional feature and is not available on all Pitney Bowes solutions. Please contact your local account representative to determine if this option is accessible on your system.

You can print a permit on a piece of mail instead of a meter stamp. You purchase permits from the US Post Office. Your permit contains a number that entitles you to special rates and discounts. Sample permits are shown here.

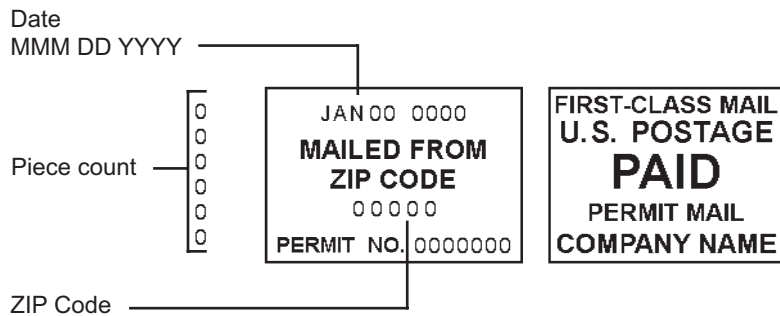

To order a permit, you need to do the following:

1. Go to the US Post Office and obtain a permit license. The Post Office provides you with the permit number(s). Contact your Sales Representative or the Pitney Bowes Supply Line™ to get the permit feature. Refer to the *Pitney Bowes Contact Information List* at the front of this guide for the Pitney Bowes Supply Line™ phone number.
2. Contact the Pitney Bowes Supply Line™ and provide them with the permit number(s). You request Pitney Bowes to create customized artwork for the permit(s). Refer to the *Pitney Bowes Contact Information List* at the front of this guide for the Pitney Bowes Supply Line™ phone number.
3. Pitney Bowes sends you the permit(s) on an art card that plugs into the side of the IntelliLink® Control Center. Refer to the *Performing Updates or Adding Features* section in *Chapter 9* in this guide.

## USPS Supplies

You can order free mailing supplies from the USPS for use with the DM500™ and DM550™ System by visiting the USPS Shipping Supplies Online web site.



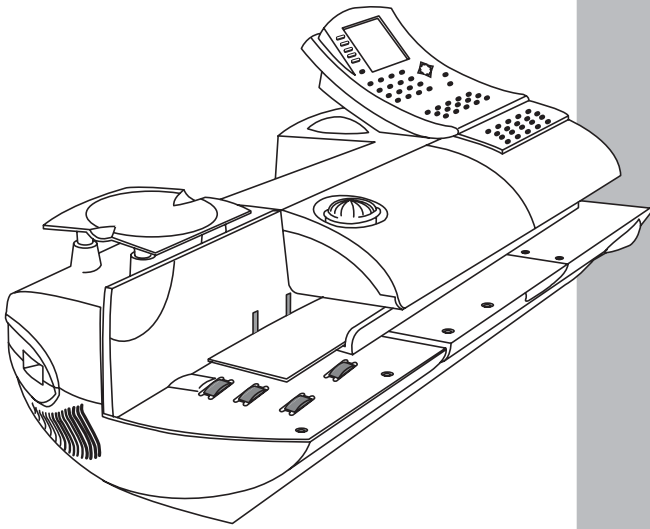

## A *Glossary*

## A • Glossary

---

Accounting	A feature of the mailing system that allows you to charge postage to individual accounts.
AccuTrac™ Mail Accounting Software	A Pitney Bowes mail accounting system software application that allows you to record postage transactions to track costs so you can charge these costs to accounts or customers.
Advertisement	Advertisements contain messages and graphics you can print next to the meter stamp.
Alpha Keyboard	The part of the keyboard used to enter accounts and other set up information.
Alphanumeric Text	Text consisting of alphabetic and numerical symbols that can include punctuation marks and other conventional symbols.
Arrow Keys	The keys you can use to move to new menus, scroll through menus, and select options.
Art Card Slot	This slot is on the right side of the IntelliLink® Control Center on the mailing machine and accepts the plug-in art card . The art card contains ads, inscriptions, and permits.
Barcode	A series of vertical bars and spaces that represent a correct ZIP code for the delivery address on a piece of mail.
Budget Manager	This is an optional enhanced accounting package you can acquire for your DM Series™ Digital Mailing System. It allows you to create and more accounts with higher levels of detail.
Business Manager	Business Manager is an enterprise accounting system that allows you to capture and manage postal transactions from the several different Pitney Bowes meters, mailing machines, and mailing systems. You can manage all systems from a single host PC that is running the Business Manager application.
Calibrate	The action performed which sets the scale at zero in order to assure accuracy.
Carrier	The service that delivers your mail such as the USPS or Federal Express.
Certified Mail	Certified Mail is a service offered by the United States Postal Service® for a fee in addition to postage. Sending Certified Mail provides a delivery record that the Postal Service maintains for a period of two years. For additional Certified Mail options, see Return Receipts or Restricted Delivery in this glossary.

Certified Mail Rates	Please refer to the USPS web site at <a href="http://www.usps.com">www.usps.com</a> for rates.
Class Key	Enables you to select the correct class for your mailing (e.g. First Class, Priority, Express Flat Rate).
Clear Key	Press to clear an entry or if no data has been entered press to take you to the previous screen.
Communications Port	Place to connect an optional Pitney Bowes scale, printer, or a PC.
Control Center	The IntelliLink® Control Center is the module mounted on top of the mailing machine that contains the graphic display, function keys, alpha, and numeric keys and the Postal Security Device (PSD).
Data Exchange	Importing account information to a program on your PC.
Delivery Confirmation	<p>Delivery Confirmation is a service offered by the United States Postal Service® that allows you to verify the date and time of delivery of your mail or, if the delivery was unsuccessful, the date and time of the delivery attempt. The service is currently available for Priority Mail and Package Services, which includes Parcel Select, Parcel Post, Bound Printed Matter, Special Standard Mail and Library Mail.</p> <p>You may combine Delivery Confirmation with other services such as COD, insured mail, registered mail, parcel airlift (PAL) or special handling.</p> <p>There is no charge for Delivery Confirmation when you ship by Priority Mail and provide an electronic file to the Postal Service. There is a per piece charge when you ship Package Services using the electronic option. To get the latest fees, go to <a href="http://www.usps.com">www.usps.com</a> and search for "Delivery Confirmation".</p>
Differential Weighing	The weighing mode that allows you to put all of the mail on the scale, then remove each piece one at time. As you remove each piece, the system calculates the weight and prints postage (either on envelopes or tapes). This saves time by eliminating the need to place each piece individually on the scale.
Error Message	An indication that notifies the operator of a disabling event (i.e, out of ink).
External Device Port	A plug on the machine that allows you to connect an optional external device, such as a scale or a PC.
E-Z Seal® Sealing Solution	The envelope moistening solution you can order from the Pitney Bowes Supply Line™.

## A • Glossary

---

Feed Deck	The area of the mailing machine where you feed the envelopes.
FIM (Facing Identification Mark)	A series of five or six vertical bars used by automated postal equipment to identify, orient, and separate reply mail.
Funds	The amount of money in your Postage meter (Postal Security Device - PSD).
Funds Key	Press to get information about funds used in a job, add funds to your meter, enter new refill amounts or get Postage By Phone® Meter Payment System balance.
High Value Warning	A warning that you have entered a postage value above the value that you have entered into the system as your maximum allowable amount. This feature prevents you from accidentally printing more postage than you need.
Indicia	See Meter Imprint.
Ink Cartridge	Cartridge containing the ink used to produce the meter stamp.
Inscription	An optional message, such as “First Class” or “Non-Profit,” that prints vertically to the immediate left of the postage imprint.
Inspection	A meter check required by the USPS.
Insufficient Funds	A warning message that alerts you when you attempt to use more postage than is currently in your Postage Meter (Postal Security Device - PSD).
IntelliLink® Control Center	See Control Center.
Jam Release Lever	Relieves the tension along the feeder path.
Lock Code	A code that locks the mailing system with a four digit password preventing unauthorized use of your meter.
Low Funds Warning	You may set your machine to warn you when your funds go below a specified amount.
Menu Key	Press to view the main settings and options available.
Meter	See Postal Security Device.



Meter Imprint (or Meter Stamp)	Postage stamp printed directly on a piece of mail or tape using a meter device in place of traditional glue or adhesive affixed stamps. This type of postage requires a special form of indicia called an “information based indicia” (IBI). The US Postal Service’s IBI Program (IBIP) is the program that makes printing of postage by a meter device possible.
Mixed Mail	Mail consisting of varying lengths and widths.
Mode Key	Press to choose from a variety of mail processing modes.
Modem	That part of the mailing system that dials the Pitney Bowes Postage By Phone® Meter Payment System center and transfers information over the phone.
Numeric Keys	The part of the IntelliLink® Control Center that you use to enter amounts and numbers.
Password	See Supervisor Password.
Permit	A permit is a special postal mark used instead of the usual meter stamp imprint. You open a permit account at the Post Office. These permits provide you with special processing or discount rates.
Postage by Phone® System	The Pitney Bowes system that allows you to purchase postage over the phone line.
Postage Meter	See Postal Security Device.
Postal Security Device (PSD)	The PSD contains the funds and performs all of the calculations necessary to print meter stamps that comply with the latest USPS standards. The PSD is contained in the DM Series™ Digital Mailing System IntelliLink® Control Center.
Postage Tape	Tape on which reports or meter stamps are printed when a piece of mail is too large or small, or too fragile to run through the mailing system.
Presets	A combination of mailing system settings you create and name so that you can call them up as a named preset thereby eliminating the need to enter each setting whenever you use this combination of settings.
Printer Nozzle	The mechanism in the print engine that sprays the ink onto the envelope or tape.
Prompt	A displayed message requesting you to respond to a choice, condition, or action.
Quick Refill	This refill repeats the same amounts of the previous refill.

## A • Glossary

---

Rate update	Changing of the postal rates by the USPS.
Reports Key	This key allows you to view a or select a report to print.
Return Receipts	A return receipt for Certified Mail serves as a legal document proving the date and time when the recipient took possession of the piece of mail. You fill out a return receipt postcard and the Postal Service sends the green return receipt postcard back to you, the sender.
Restricted Delivery	Restricted Delivery for Certified Mail requires your USPS carrier to deliver only to the person you specified. This person must sign for the mail.
Screen Keys	The five keys directly to the left of the display screen that allow you to select options from the menus displayed on the screen.
Seal Key	Press if you want to seal your envelopes without applying postage.
Shingle	A way to arrange pieces of mail in stepped positions for feeding, so that the mail is accepted one at a time.
Side Guide	The moveable guide at the front of the feed deck used to stabilize the envelope position when feeding it.
Signature Confirmation	<p>A signature proof of delivery service which provides mailers with the signature and text name of the recipient, along with the date, time, and ZIP Code that is provided with Delivery Confirmation. Actual signatures can be easily obtained from the USPS via fax or mail. This service meets the needs of mailers who require a signature for high-value shipments, legal requirements, or who are specifically concerned with avoiding fraud. For security purposes, digital signatures are not publicly displayed on the web site.</p> <p>Signature Confirmation may be combined with special services. To get the latest fees, go to <a href="http://www.usps.com">www.usps.com</a> and search for "Signature Confirmation".</p>
Sleep Timer	The mode that the mailing system automatically enters after a certain period of inactivity.
Stacker	The holder at the end of the feeder path where mail is deposited. Two types of stackers are available: tabletop drop-stacker and power-stacker.
Supervisor Password	Code that restricts access to certain mailing system operations.
Tape Exit	Location where the tape comes out of the right side of the mailing system.

Test Pattern	The pattern printed during a test to show the clarity of the meter imprint.
Thickness Adjustment Knob	Adjusts the tension to accommodate the thickness of the pieces of mail you are feeding.
Tyvek®	A plastic material used for envelopes.
USPS	The United States Postal Service.
Wiper Blade	Part of the printing assembly that wipes excess ink off the printhead.
ZIP Code	A ZIP Code is a numeric code used by the USPS to identify general and specific geographic areas in the United States.
ZIP+4 Code	A 9-digit numeric code incorporating the original 5-digit ZIP Code, a hyphen, and 4 additional digits. The first 5 digits identify the delivery office. The 4-digit add-on identifies specific delivery segments.



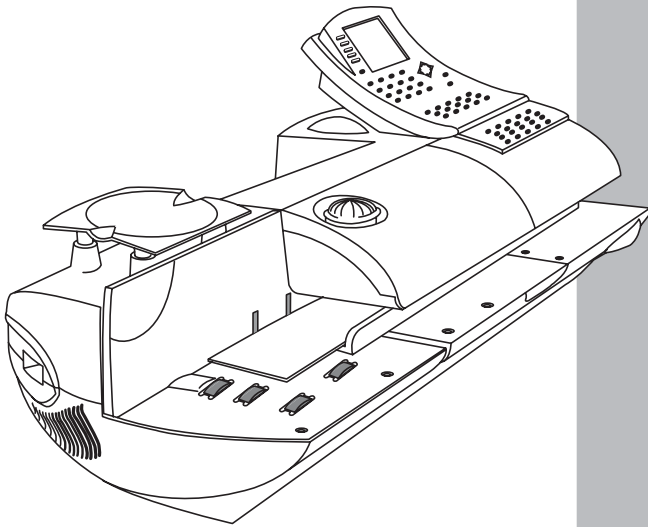

## Appendix B - Operator Training Checklist

The following checklist includes the topics your Pitney Bowes representative will discuss with you to ensure that you fully understand how to operate your DM Series™ Digital Mailing System.

The checklist is divided into the following sections:

Learning About Your System.....	B-2
Basic Operations .....	B-3
Advanced Operations* .....	B-4
If You Need to Change Your System Setup .....	B-5
What You Need to Maintain Your System ....	B-7
If You Have Problems with Your System .....	B-8

\*The Advanced Operations section contains topics for all possible options you can purchase with your system. Your representative will cover only those options that apply to your specific system configuration.

For additional training options, contact your local sales professional.

## B • Operator Training Checklist

---

### Learning About Your System

Place a check mark in the **Done** box when you complete the topic.

<b>Learning About</b>	<b>Refer to Chapter and Section</b>	<b>Page</b>	<b>Done</b>
System controls, connections and their locations.	<i>Chapter 2, Parts of Mailing System</i>	2-5	
The IntelliLink® Control Center and the main display screen.	<i>Chapter 2, The IntelliLink® Control Center</i>	2-12	
DM Series™ Digital Mailing System throughput.	<i>Appendix C, Specifications</i>	C-2	
Mailing material you can use with your DM™ Series System.	<i>Appendix C, Mailing Material</i>	C-4	
How to get technical phone support.	<i>Pitney Bowes Contact Information List</i>		
How to get information on the web.	<i>Pitney Bowes Contact Information List</i>		
Critical safety information.	<i>Chapter 1, Safety Requirements</i>	1-5	

## Basic Operations

Place a check mark in the **Done** box when you complete the topic.

<b>How to do the following:</b>	<b>Refer to Chapter and Section</b>	<b>Page</b>	<b>Done</b>
Move around, select and enter information in the main screen.	<i>Chapter 4, Navigating Hints</i>	4-2	
Determine the best way to run mail on your DM Series™ system.	<i>Chapter 4, Determining the Correct Postage Mode</i>	4-4	
Select the way you are going to run mail on your system.	<i>Chapter 4, Selecting the Postage Mode and Running Mail</i>	4-8	
Get your mail ready to run on your system.	<i>Chapter 4, Preparing Your Mail</i>	4-6	
Pick a class, carrier and/or special service for your mail.	<i>Chapter 4, Selecting a Class, Carrier or Special Service</i>	4-15	
Choose an account if you are using accounting on your system.	<i>Chapter 4, Selecting or Deselecting an Account</i>	4-14	
Add postage to your mail after you have already printed it.	<i>Chapter 4, Adding Postage or Changing the Date</i>	4-26	
Change the date on your mail after you have already printed it.	<i>Chapter 4, Adding Postage or Changing the Date</i>	4-27	
Connect your IntelliLink® Control Center (which contains your postage meter) to an analog phone line for adding postage and downloading updates.	<i>Chapter 6, Connecting Your Postage Meter to an Analog Phone Line</i>	6-4	
See how much money you have in your postage meter.	<i>Chapter 6, Checking Available Funds in Your Postage meter</i>	6-6	
See how much money is in your Pitney Bowes account.	<i>Chapter 6, Checking Your Postage By Phone® Meter Payment System Account Balance</i>	6-7	
Add postage to your postage meter.	<i>Chapter 6, Adding Postage</i>	6-8	
Print a report on an envelope or on a tape	<i>Chapter 8, Printing a Report</i>	8-2	
Order replacement supplies for your DM Series™ Digital Mailing System.	<i>Chapter 11, Ordering Supplies</i>	11-2	

### Advanced Operations

Place a check mark in the **Done** box when you complete the topic.

<b>How to do the following:</b>	<b>Refer to Chapter and Section</b>	<b>Page</b>	<b>Done</b>
Change or advance the date to be printed on your envelope or tape (this does not change your system's date).	<i>Chapter 4, Meter Stamp Options: Date</i>	4-17	
Add advertisements to your meter stamp.	<i>Chapter 4, Meter Stamp Options: Advertisement</i>	4-18	
Add inscriptions to you meter stamp.	<i>Chapter 4, Meter Stamp Options: Inscription</i>	4-19	
Change the location on the envelope where you print the meter stamp.	<i>Chapter 4, Meter Stamp Options: Print Position</i>	4-20	
Define presets so you can recall specific settings on your mail system.	<i>Chapter 5, Defining Presets</i>	5-21	
Use confirmation services (adding barcode labels to your mail)	<i>Chapter 4, Using Confirmation Services</i>	4-23	
Track your confirmation services records on the internet.	<i>Chapter 4, Tracking Information on the Internet</i>	4-22	
Clear the number of mail pieces you have processed on your system.	<i>Chapter 4, Clearing the Batch Count</i>	4-28	
Add a supervisor password to your system to prevent operators from performing certain operations (like adding postage, or clearing the number of mail pieces).	<i>Chapter 5, Setting Up a Supervisor Password</i>	5-6	
Add a lock code to your system to keep unauthorized operators out.	<i>Chapter 5, Setting Up a Lock Code</i>	5-7	
Add new features or updates to your system using the IntelliLink® Control Center.	<i>Chapter 9, Performing Updates or Adding Features</i>	9-23	



## If You Need To Change Your System Setup

Place a check mark in the **Done** box when you complete the topic.

<b>How to do the following:</b>	<b>Refer to Chapter and Section</b>	<b>Page</b>	<b>Done</b>
Change the date on your DM system.	<i>Chapter 5, Setting the Date and Time of Day</i>	5-5	
Set up a new scale or change settings on an existing scale, including:	<i>Chapter 5, Setting Up the Scale and Selecting Rates</i>	5-8	
<ul style="list-style-type: none"> <li>• adjust for the scales environment.</li> </ul>	<i>Chapter 5, Scales/Rates: Attached Scale</i>	5-8	
<ul style="list-style-type: none"> <li>• set your system to automatically recognize the scale.</li> </ul>	<i>Chapter 5, Scales/Rates: Auto-scale</i>	5-9	
<ul style="list-style-type: none"> <li>• set up to use differential weighing.</li> </ul>	<i>Chapter 5, Scales/Rates: Diff Weigh Trip Weight</i>	5-9	
<ul style="list-style-type: none"> <li>• set up to clear or retain the class value when you add a new weight on the scale.</li> </ul>	<i>Chapter 5, Scales/Rates: Class if New Piece</i>	5-9	
<ul style="list-style-type: none"> <li>• set up to clear or retain the ZIP or Zone value when you add a new weight on the scale.</li> </ul>	<i>Chapter 5, Scales/Rates: Destination if New Piece</i>	5-10	
<ul style="list-style-type: none"> <li>• set up to clear or retain the ZIP or Zone value when the class changes.</li> </ul>	<i>Chapter 5, Scales/Rates: Destination if New Class</i>	5-10	
<ul style="list-style-type: none"> <li>• set up to prompt the operator for a ZIP Code or Zone.</li> </ul>	<i>Chapter 5, Scales/Rates: ZIP/Zone Prompt</i>	5-10	
<ul style="list-style-type: none"> <li>• set up a group of ZIP Codes for a bulk mailing center.</li> </ul>	<i>Chapter 5, Scales/Rates: BMC Intra ZIP</i>	5-11	
<ul style="list-style-type: none"> <li>• add ZIP Codes to a Zone 0 rate.</li> </ul>	<i>Chapter 5, Scales/Rates: Add ZIPs to Zone 0</i>	5-11	
Set the value at which you are warned that you are running low on funds in your meter.	<i>Chapter 5, Configuring High/Low Funds Warnings</i>	5-17	
Set the value at which you are warned that you are running low on ink for printing your postage.	<i>Chapter 5, Configuring Low Ink Warning</i>	5-17	

**If You Need To Change Your System Setup (continued)**

Place a check mark in the **Done** box when you complete the topic.

<b>How to do the following:</b>	<b>Refer to Chapter and Section</b>	<b>Page</b>	<b>Done</b>
Change timeouts on your DM system, including: <ul style="list-style-type: none"> <li>• set how long the main screen can remain inactive before turning off.</li> <li>• set how long your system can remain inactive before it shuts down power to the printer and the meter.</li> <li>• set how much time to wait before your system restores the default or normal preset values.</li> <li>• set up how much time to wait before the feeder stops after the last envelope is fed.</li> <li>• set up how much time the system will continue to feed mail placed on the feed deck without having to press the <b>Start</b> key.</li> </ul>	<i>Chapter 5, Configuring System Timeouts</i>	5-18	
	<i>Chapter 5, Configuring System Timeouts: Display Sleep</i>	5-18	
	<i>Chapter 5, Configuring System Timeouts: System Sleep</i>	5-18	
	<i>Chapter 5, Configuring System Timeouts: Normal Preset Timer</i>	5-19	
	<i>Chapter 5, Configuring System Timeouts: Feeding Timeout</i>	5-19	
	<i>Chapter 5, Configuring System Timeouts: Waiting for Env</i>	5-20	
Set up your system for a barcode scanner.	<i>Chapter 5, Configuring the Optional Barcode Scanner</i>	5-26	

## What You Need to Maintain Your System

Place a check mark in the **Done** box when you complete the topic.

<b>How to do the following:</b>	<b>Refer to Chapter and Section</b>	<b>Page</b>	<b>Done</b>
Determine what supplies you need to keep on hand.	<i>Chapter 9, Items to Keep on Hand</i>	9-2	
Clean the outside of your DM Series™ Digital Mailing System.	<i>Chapter 9, Cleaning the Exterior</i>	9-2	
Replace the tape roll.	<i>Chapter 9, Tape Maintenance</i>	9-3	
Refill the E-Z Seal® Sealing Solution.	<i>Chapter 9, E-Z Seal® Maintenance</i>	9-5	
Clean the moistener brush that wets the envelope flap.	<i>Chapter 9, Moistener Maintenance</i>	9-6	
Replace the moistener wick for the moistener brush.	<i>Chapter 9, Cleaning or Replacing the Wick</i>	9-8	
Check the print quality by doing a print test.	<i>Chapter 9, Printer Maintenance</i>	9-13	
Change the printhead.	<i>Chapter 9, Changing the Printhead</i>	9-18	
Change the wiper blade on the printhead.	<i>Chapter 9, Changing the Wiper Blade Assembly</i>	9-22	
Replace the ink cartridge.	<i>Chapter 9, Replacing the Ink Cartridge</i>	9-15	

### If You Have Problems with Your System

Place a check mark in the **Done** box when you complete the topic.

<b>What to do if the following occurs:</b>	<b>Refer to Chapter and Section</b>	<b>Page</b>	<b>Done</b>
Envelopes are not sealing correctly.	<i>Chapter 10, Envelope Sealing Problems</i>	10-2	
Envelopes are not feeding correctly, or are getting jammed.	<i>Chapter 10, Envelope Feeding Problems</i>	10-3	
Tape is jamming.	<i>Chapter 10, Tape Feeding Problems</i>	10-6	
Postage is not printing correctly.	<i>Chapter 10, Printing Problems</i>	10-6	
Cannot add postage to your meter.	<i>Chapter 10, Problems Adding Postage to Your Postage Meter</i>	10-8	
Difficult to read the display	<i>Chapter 10, Display Problems</i>	10-8	
Getting erratic readings from the scale.	<i>Chapter 10, Weighing Problems</i>	10-9	

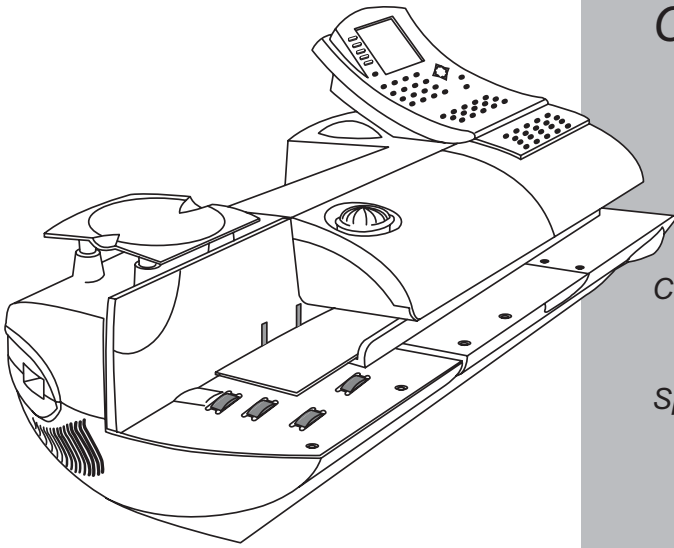

## C Specifications

### Contents

Specifications .....	C-2
Mailing Materials.....	C-4
Envelope Dimensions.....	C-5

Specifications

<b>Dimensions and Weight</b>	<b>DM500™ (DGF1<sup>(1)</sup>, DEP0<sup>(2)</sup>)</b>	<b>DM550™ (DHF1<sup>(1)</sup>, DEP0<sup>(2)</sup>)</b>
Size (inches): w/o Stacker	35L x 15H x 19W	
Size (mm): w/o Stacker	889L x 381H x 483W	
Weight (lbs):	64	66
Weight (kgs):	29	30
<b>Electrical and Power</b>		
Electrical Power Requirements VAC +/- 1 Hz	120-240	
Power Consumption:	145W	
<b>Operating Conditions</b>		
Temperature Range F (C)	Min 40 (04), Max 100 (43)	
Relative Humidity	Min 8%, Max 95%	
<b>Capacities and Features</b>		
Feeder Type	Automatic with deskew	
Feeder Deck Capacity	4 inches (102 mm) for a stack of mail	
Side Guide	Yes	
Storage Fluid in Storage Tank	Enough to seal approximately 3000 pieces of mail	
Throughput Speed #10 Envelopes <sup>(3)</sup>	135 (DM500™)	160 (DM550™)
Throughput Speed Tape/min for longest meter stamp	14	

- (1) This number identifies the feeder module portion of your system and is located on a label on the left side of the base.
- (2) This number refers to the finishing (printer) module and is located on a label on the right side of the finishing base.
- (3) The actual throughput of your mailing system may vary depending on the material processed and skill of the operator.

## DM500™ and DM550™ Digital Mailing System Operating Guide

Capacities and Features	DM500™ (DGF1 <sup>(1)</sup> , DEP0 <sup>(2)</sup> )	DM550™ (DHF1 <sup>(1)</sup> , DEP0 <sup>(2)</sup> )
Sealing Method	Sealing with flap closed.	
E-Z Seal® Fluid Sensing	Warning method for low fluid level of E-Z Seal®.	
Stacker Type	Drop stacker	
Stacker Capacity for #10 Envelopes	4 inches (102 mm)	
Ink Capacity	Up to 9,300 impressions without an advertisement. Up to 4500 impressions with an advertisement. (Note: these quantities require a minimum of 80 impressions per day).	
Internal Modem	56 Kbytes/sec	
Telephone Cord for Analog Line	26 AWG or smaller	
Optional Integrated Scale	Platform (5 or 10 lbs. capacity)	
Advertisements	Up to 10 custom advertisements plus preloaded advertisements (see <i>Chapter 11</i> in this guide for a list of the preloaded advertisements).	
Inscriptions	Up to 20 custom inscriptions plus preloaded inscriptions (see <i>Chapter 11</i> in this guide for a list of the preloaded inscriptions).	
Permit Mail Image	Maximum number of images is 3. Maximum identifying image name length is 15 characters. (An option you may be able to purchase. Not available on all systems.).	
Accounting Features	DM500™ (DGF1 <sup>(1)</sup> , DEP0 <sup>(2)</sup> )	DM550™ (DHF1 <sup>(1)</sup> , DEP0 <sup>(2)</sup> )
Standard Accounting	25 standard accounts or optional 100 or 300 accounts.	
Optional Budget Manager	Budget Manager allows you to create more accounts with higher levels of detail.	

- (1) This number identifies the feeder module portion of your system and is located on a label on the left side of the base.
- (2) This number refers to the finishing (printer) module and is located on a label on the right side of the finishing base.

**Specifications**

continued

***Mailing Materials:***

<b>Envelope Dimensions (refer to envelope measurement figure on next page)</b>	
Minimum	3 in. x 5 in. (76.2 mm x 127 mm) postcard size.
Maximum	11 in. x 13 in. (279 mm x 330 mm) in landscape orientation. C5 envelopes can be processed when in portrait orientation.
<b>Envelope Flap Depth (refer to envelope measurement figure)</b>	
Minimum	1 in. (25.4 mm)
Maximum	3 in. (76.2 mm)
<b>Envelope Thickness</b>	
Minimum	0.007 in. (0.18 mm)
Maximum	5/8 in. (15.9 mm)
<b>Acceptable Envelope Materials Include</b>	
<ul style="list-style-type: none"> <li>• Standard envelope paper</li> <li>• Self-mailers</li> <li>• Tri-fold mail</li> <li>• Pre-sealed envelopes</li> </ul>	
<b>Envelope Flap Profiles</b>	
<ul style="list-style-type: none"> <li>• Commercial (square and baronial)</li> <li>• Executive</li> <li>• Monarch</li> </ul>	
<b>Weight of the piece of mail</b>	
5 or 10 lbs. maximum for each piece (depending on capacity of optional scale)	
<b>Tape Roll Width</b>	
Either 4 in. (102 mm) or 5 inches (127 mm)	



**Envelope Dimensions**

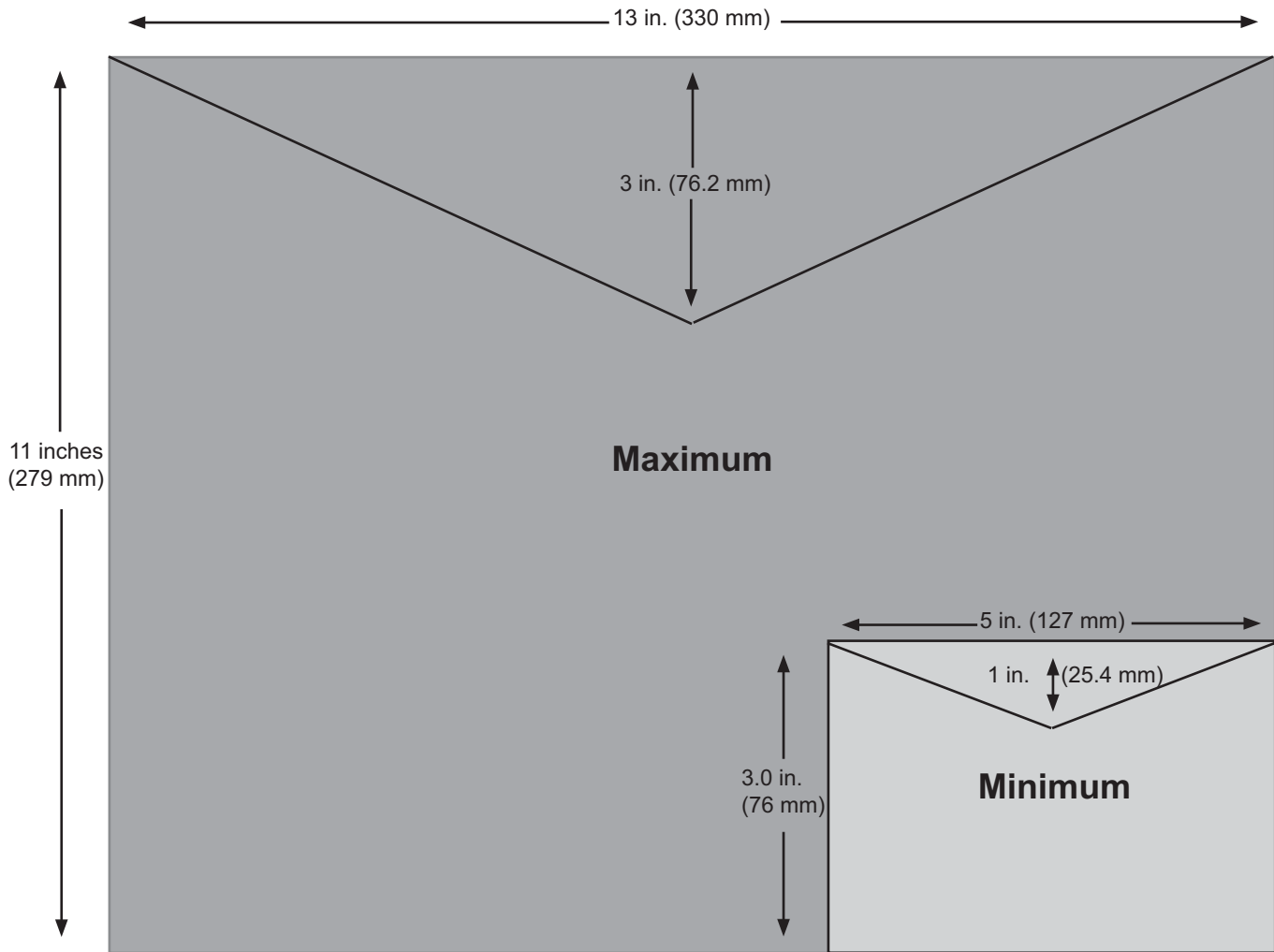



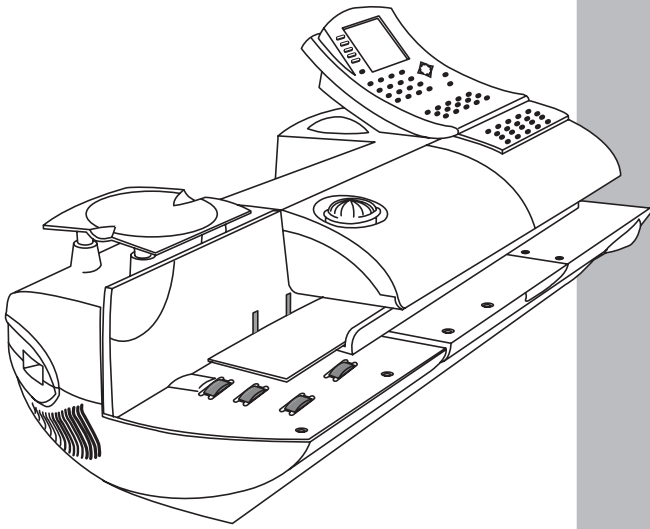

## *Index*

# Index

---

## A

- Accessories
  - description 2-4,11-4
  - ordering 2-4,11-4
- Accounting
  - selecting the accounting type 7-13
  - set up mode 7-2
  - turning off accounting 7-13
- Accounts
  - accessing features 7-2
  - adding subaccounts to 7-5
  - changing name 7-5,7-7
  - changing number 7-5
  - changing password 7-5
  - changing status 7-7
  - checking Postage By Phone® balance 6-7
  - clearing account information 7-10
  - deselecting 4-14
  - enabling/disabling 7-8
  - explaining account structure 7-15,7-16
  - overview 2-4
  - selecting a period 7-8
  - selecting to print postage 4-14
  - transferring funds 7-11
- Accounts key
  - description 2-12
  - location 2-13
- Account list report 8-8
- AC adapter
  - connector location 2-8,2-9,6-4,6-5
- Adding fund to your postage meter 6-8
- Advance Date
  - storing in a custom preset 4-17,5-22
- Advertisements
  - included with system 11-4
  - ordering 2-4,11-4
  - selecting 4-18
- Alpha keyboard
  - description 2-13
  - location 2-13
- Analog phone line
  - definition 2-8
- Analog phone line connection 2-9,6-4,6-5
- Arrow keys
  - description 2-13
  - location 2-13
  - on the main screen 4-2,5-2
- Art card
  - location 2-6
  - to perform updates 9-24

## B

- Barcodes
  - using for USPS Confirmation Services 4-23
- Barcode scanner
  - configuring 5-26
- Batch count
  - clearing or resetting 4-28
  - on the main screen 2-14
- Budget Manager
  - description 2-4
  - selecting 7-13

## C

- Class key
  - description 2-12
  - location 2-13
- Cleaning
  - exterior of mailing system 9-2
  - moistener brush 9-6
  - moistener wick 9-8
  - printer nozzle 9-14
- Clear key
  - description 2-13
  - location 2-13
- Communications
  - location of ports 2-7
  - options 2-3
- Confirmation services
  - see USPS confirmation services 11-3
- Connectors
  - mailing machine base 2-7
  - on IntelliLink® Control Center 2-8
- Correcting postage 4-26
- Correcting the date 4-27
- Cover
  - feed
    - location 2-6
  - main
    - location 2-6
- Custom presets key
  - description 2-12
  - how to define preset values 5-22,5-24
  - location 2-13

## D

- Data capture report 8-13
- Date
  - advancing the date 5-5
  - selecting date options 4-17
  - setting date options 5-5

Daylight saving  
  setting up 5-5  
Dialing prefix 5-13  
Differential weighing  
  how to use 4-10  
  when to use 4-5  
Discount codes 5-11  
Display  
  adjust the contrast 5-4  
  setting the sleep timer 5-18

## E

E-Z Seal® 9-5  
  adding more solution 9-5  
  checking the level in moistener tank 9-10  
  Ordering 11-2  
E-Z Seal® bottle  
  description 2-10  
  location 2-10  
Energy Star Compliance 2-2  
Enter key  
  description 2-13  
  location 2-13  
Envelopes  
  dimensions C-5  
  shingled 3-2,4-6  
Error report 8-11  
External device ports  
  mailing machine base 2-7

## F

Feed deck  
  location 2-6,2-10  
Funds  
  setting the high value warning 5-17  
  setting the low funds warning 5-17  
  transferring account funds 7-11  
Funds key  
  adding postage 6-8  
  checking available funds 6-6  
  check Postage By Phone® 6-7  
  clear batch number 4-28  
  description 2-12  
  location 2-13  
Funds report 8-9

## H

Help  
  Postage By Phone® System 6-2  
  Quick Reference Guide 1-3

High funds warning  
  description 5-17  
  setting up 5-17

## I

Ink cartridge  
  location 2-11  
  ordering 11-2  
  replacing 9-15,9-16  
Inscriptions  
  included with system 11-4  
  ordering 2-4,11-4  
  selecting 4-19  
Inspections  
  notification of 1-4,6-2  
  required by USPS 6-2  
IntelliLink® Control Center  
  connected to remote analog line 2-9  
  definition 2-3,2-5  
  keys 2-12,2-13  
  location 2-6  
  main screen 2-14  
IntelliLink® Control Center (ICC)  
  connected to remote analog line 6-5

## J

Jams  
  clearing envelope in feed deck 10-4  
  clearing envelope in transport 10-5  
Jam release levers  
  description 2-10  
  location 2-10,10-4  
Job report 8-12

## K

Key in Postage  
  when to use 4-4

## L

Language  
  options 5-4  
  select 5-4  
Last 5 refills report 8-6  
Loading a tape roll 9-3  
Lock button  
  description 2-12  
  location 2-13  
Low funds warning  
  description 5-17  
  setting up 5-17

# Index

---

## M

### Mail

- determining the postage mode 4-4,4-5
- preparation 3-2,4-6
- quick setup and start 3-2
- selecting the postage mode 4-8

### Mailing materials C-4

### Mailing system

- art card slot 2-5
- covers 2-5
- description 2-5
- feed deck 2-5
- on/off switch 2-5
- platform scale (optional) 2-5
- side guide 2-5
- stacker 2-5
- transport release knob 2-5

### Maintenance

- cleaning the exterior 9-2
- cleaning the printer nozzle 9-14
- moistener brush assembly 9-6
  - cleaning/replacing the brush 9-6
  - cleaning/replacing the wick 9-8
- printing a test pattern 9-13
- replacing the E-Z Seal® 9-5
- replacing the ink cartridge 9-15
- replacing the printhead 9-18
- replacing the tape 9-3
- replacing the wiper blade assembly 9-22

### Main screen

- advertisement display 2-14
- description 2-14
- postage indicia 2-14
- status area 2-14

### Menu key

- description 2-12
- location 2-13
- using to change elements on mail 4-17

### Meter stamp

- change the elements of 4-17
- on the main screen 2-14

### Modem

- advanced connection settings 5-16
- connecting to control center 2-8,6-4
- determining which connector to use 6-4
- selecting dialing sound 5-14,5-15
- setting up 5-12

### Mode key

- description 2-12
- location 2-13
- using to select postage mode 4-8
- when running mail 3-3

### Moistener brush assembly 9-6

- cleaning/replacing the brush 9-6
- cleaning/replacing the wick 9-8
- cleaning the tank 9-9
- location 9-7
- tank location 9-8

### Moistener kit

- ordering 11-3

### Multi-account summary report 8-4

## N

### Navigating hints

- running mail 4-2
- setting up accounting 7-2
- setting up mailing system 5-2

### Normal preset key

- description 2-12
- how to set up 5-21
- location 2-13

### Normal preset timeout 5-19

### Numeric keys

- description 2-12
- location 2-13

## O

### On/off switch

- location 2-6

### Ordering supplies 11-2

- E-Z Seal® 11-2
- ink cartridges 11-2
- tape 11-2

## P

### Passwords

- changing account password 7-7
- protecting mail operations 5-6
- setting up for each account 7-5
- setting up supervisor 5-6
- turning on/off for accounting 7-9

### PB Supply Line™ 2-4

### Permit

- defined 2-4
- selecting 4-13

- Permit mail report 8-8
- Platform scale (optional)
  - location 2-6
- Postage
  - adding more postage 4-26
- Postage By Phone® System 6-2
  - checking funds in account 6-7
  - checking funds in postage meter 6-6
  - entering the dialing prefix 5-13
  - entering the number to dial 5-13,5-14
  - setting up 5-12
  - setting up your account 5-13
- Postage funds
  - adding to postage meter 6-8
  - checking account 6-7
  - managing 6-3
- Postage meter 6-2
  - adding funds 6-8
  - connecting to analog line 6-4
  - connecting to remote analog line 6-5
  - inspection 1-4
  - rekey requirements 6-2
  - removing from service 5-25
  - USPS inspections 6-2
- Postage modes
  - attached scale 4-5
  - attached scale - autotape 4-5
  - differential weighing 4-5,4-10
  - key in postage 4-5,4-9
  - manual weight entry 4-5
  - seal only 4-5,4-13
  - time and date stamp 4-5
- Postage tape
  - description 2-10
  - location 2-10
  - printing 3-4
  - specifications C-4
  - when to use 3-4,4-7
- Postal Security Device 2-2,6-2
- Presets
  - custom presets
    - how to define 5-22
    - how to delete 5-24
    - how to edit 5-24
    - how to rename 5-24
    - how to view 5-24
  - normal preset
    - how to define 5-21
- Printer
  - adding optional attached 5-25
  - attached (external) 8-2
  - cleaning the nozzle 9-14

- location of USB connector 2-7,5-25
- maintenance 9-13
- printing a test pattern 9-13

Printhead

- location 2-11
- ordering replacement 11-3
- replacing 9-18

Printing postage

- on envelopes 3-3,4-9
- on tape 3-4,4-7

Printing tapes 3-4

## Q

Quick Reference Card

- definition 2-5
- location 2-6

## R

Rates

- adding ZIPs to zero zone 5-11
- setting up discount codes 5-11

Reports

- account list 8-8
- data capture 8-13
- error 8-11
- funds 8-9
- job 8-12
- last 5 refills 8-6
- multi-account summary 8-4
- overview 2-4
- permit mail 8-8
- selecting a 8-3
- single account 8-3
- system setup 8-10

Reports key

- description 2-12
- location 2-13

## S

Scales

- password protecting setup 5-6
- procedures for setting up 5-8
- setting up attached scale 5-8
- setting up autoscale 5-9
- setting up ZIP code prompt 5-10
- setting up Zone prompt 5-10
- weighing problems 10-9,10-10

Scanner

- configuring the barcode scanner 5-26

# Index

---

- Screen keys
    - description 2-12
    - location 2-13
  - Seal key
    - description 2-12
    - location 2-13
    - when running mail 3-2,4-6
  - Side guide
    - adjusting for mail 3-3,4-6
    - correct setting 4-6
    - location 2-6
  - Single account report 8-3
  - Specifications
    - mailing materials C-4
    - width of tape rolls C-4
  - Stacker
    - definition 2-5
  - Start key
    - description 2-13
    - location 2-13
  - Subaccount
    - add 7-5,7-6
  - Subsubaccount
    - add 7-5
  - Supplies
    - ordering 11-2
  - System Setup Report 8-10
  - T**
  - Tape
    - installing 9-3
    - ordering 11-2
    - specifications C-4
  - Tape key
    - description 2-13
    - location 2-13
    - when printing tapes 3-4
  - Thickness adjustment knob
    - description 2-5
    - location 2-6,2-10
    - possible problems 10-3,10-4
    - settings 2-10
  - Timeouts
    - display sleep 5-18
    - feeder 5-19
    - normal preset 5-19
    - transaction 5-20
    - waiting for envelope 5-20
  - Transport release knob
    - location 2-6
  - Troubleshooting
    - display problems 10-8
    - envelope feeding problems 10-3,10-4,10-5
    - envelope sealing problems 10-2
    - printing problems 10-6,10-7
    - problems adding postage 10-8
    - tape feeding problems 10-6
    - weighing problems 10-9,10-10
  - U**
  - Updates
    - performing 9-23
  - USB ports
    - base of mailing machine 2-7
  - USPS confirmation services 4-21
  - editing or deleting records 4-25
  - ordering labels 11-3
  - using after printing 4-24
  - using barcodes 4-23
  - using before printing 4-23
- W**
- Weighing mail
  - differential weighing 4-10
- Weighing problems 10-9,10-10
- Weight
  - on the main screen 2-14
- Wiper blade
  - ordering replacement 11-3
  - replacing 9-22
- Z**
- ZIP Code
  - entering 4-16
  - setting system to prompt for 5-10
- Zone
  - entering 4-16
  - setting system to prompt for 5-10