



*Partner in Growing*



## User Manual

Original document

version 2014-1-2

## Super / Super Mega

Machine nr.: .....



Javo BV  
PO Box 21  
2210 AA Noordwijkerhout  
Holland  
T: +31 (0)252 343121  
F: +31 (0)252 377423  
info@javo.eu  
www.javo.eu

© All rights reserved

The information provided herein may not be reproduced and/or published in any form, by print, photo print, microfilm or any other means whatsoever (electronically or mechanically) without the prior written authorisation of JAVO BV.

## Preface

This user manual is written for anyone working on or with the machine. Before working on or with the machine, first read this manual.

This user manual contains important instructions / information on how to use the machine in a safe, professional and economical way and must always be available where the machine is used.

In addition to this user manual, the mandatory rules and regulations for accident prevention and environmental protection in the country and place of use of the machine must also be observed.

This user manual contains information on the operation of the machine with all the possible options. Use only the information that applies to your machine. Depending on the intensity of use and customer requirements, this machine can be equipped with various options. Contact your sales consultant.

Supplier details if not directly supplied by Javo BV. Dealer stamp:



Javo BV is not responsible for any errors in this manual or the consequences thereof.

Javo BV is not liable for damage or consequential damage caused by operating errors, lack of expert maintenance and any use other than described in this manual.

The liability of Javo BV also expires once modifications or additions are made without written permission of Javo BV.

This machine is suitable for process and environmental conditions as stated in section "Specifications and Tolerances" of this manual. Any other use is not authorized by Javo BV and this allows the operator and / or its environment at risk.

## Table of contents

<b>1</b>	<b>Technical specifications and tolerances .....</b>	<b>4</b>
1.1	Type plate.....	4
<b>2</b>	<b>Safety.....</b>	<b>5</b>
2.1	Provisions .....	5
2.2	Safety devices on the machine .....	6
2.3	Explanation of icons and symbols.....	6
<b>3</b>	<b>Description of the machine .....</b>	<b>7</b>
3.1	Machine overview.....	7
3.2	Outline drawing with main dimensions .....	7
3.3	Options.....	8
3.4	Operation .....	10
3.5	Machine workstations.....	10
3.6	Controls.....	11
<b>4</b>	<b>Transport .....</b>	<b>12</b>
<b>5</b>	<b>Mounting, installation and commissioning .....</b>	<b>13</b>
5.1	Placement .....	13
5.2	Facilities to take care of by the user .....	13
5.3	Mounting / Connecting.....	13
5.4	Check rotation direction .....	14
5.5	Check drill rotation direction .....	14
5.6	Center the drill .....	15
5.7	Set drillsize .....	15
5.8	Check substrate conveyor tension.....	15
5.9	Check pottrack chain tension.....	16
5.10	Check paddlewheel belts tension .....	16
5.11	Set the substrate conveyor speed .....	17
5.12	Set pottrack speed .....	17
5.13	Changeover potholders.....	18
5.14	Set scraper height .....	18
5.15	Set the funnel.....	19
<b>6</b>	<b>Operation.....</b>	<b>20</b>
6.1	Start.....	20
6.2	Stop .....	20
6.3	Emergency stop.....	20
<b>7</b>	<b>Maintenance .....</b>	<b>21</b>
7.1	Required tools and equipment .....	21
7.2	Preventive Maintenance.....	21
7.3	Paddlewheel cleaning .....	22

---

7.4	Empty substrate bin .....	22
7.5	Test safety circuit .....	22
7.6	Lubrication drill unit .....	22
7.7	Fault list .....	23
7.8	Pottrack pawl .....	24
7.9	Drawings and schemes.....	25
7.10	Spare parts .....	25
7.11	JavoNet.....	25
7.12	Customer support and advice.....	25
<b>8</b>	<b>Disposal of machine or machine parts .....</b>	<b>25</b>
<b>9</b>	<b>EG-conformity statement.....</b>	<b>26</b>

## 1 Technical specifications and tolerances

This machine is intended to be used for filling pots automatically with substrate only. This machine is meant for processing pots, substrate and other materials that are described in this manual only. Detailed operation of the machine is described in section "Operation".



*This machine may be used only within the limits for specifications and tolerances of the order, on the assembly drawing and indicated in this manual. If the machine is used outside these specifications, Javo BV cannot take responsibility for this machine.*



*This machine is intended for products as agreed in the order confirmation only. To ensure the proper operation of this machine, only products with specifications and tolerances as specified in the order may be used.*



*Do not use the machine for purposes other than the intended purpose of Javo BV. This can lead to damage and danger to the operator and its environment.*







*This machine is CE marked. When placing multiple machines in one line, the entire line must be properly CE marked before using this machine. Until proper CE Marking of the line is carried out, commissioning of this machine is prohibited.*

Specifications	
Voltage	400Volt 50Hz 3~+N+ PE
Machine connection	16A 5pole
Switched socket	1x 16A 5 pole
Power consumption	2,95 kW
Weight	Super: ±1100 kg Super Mega: ±1300 kg
Height conveyor	870 mm
Length x Width x Height	Super: 4110 x 1500 x 1840 mm Super Mega: 4955 x 1500 x 1840 mm
Max. speed (pulley 118 fan belt B33)	3.120 p. p/hour
Min. speed (pulley 118 fan belt.B33)	1.440 p. p/hour
Minimum pot diameter	5,5 cm
Maximum pot diameter	24 cm
Standard distance pottrack between pots	250mm
Number of potholders	Super: 19 distance between pots 250 Super Mega: 24 distance between pots 250
Content substrate bin	1100 Litre
Drillbush (motor shaft size 19 mm)	Drill shaft 14 mm (up to drill 15 cm)
Year of construction	See type plate
Type product	As agreed in the order confirmation.

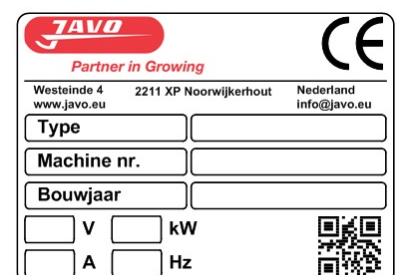
### 1.1 Type plate

The type plate is placed onto the main cabinet door.



  
 Partner in Growing  
 Westeinde 4 2211 XP Noorwijkerhout Nederland  
 www.javo.eu info@javo.eu  
 Type   
 Machine nr.   
 Bouwjaar   
 V  kW  
 A  Hz  

## 2 Safety



*This machine is built according the state of the art technique and the accredited safety regulations. Despite this, the body and life from the user or third parties can be in danger when using it. There could also arise damage to the machine or other goods when using it.*



*This machine is CE marked. When placing multiple machines in one line, the entire line must be properly CE marked before using this machine. Until proper CE Marking of the line is carried out, commissioning of this machine is prohibited.*

### 2.1 Provisions

1. Operation and maintenance of this machine must be performed by qualified personnel in compliance with warnings on the machine and in accordance with the user manual. Keep children and other (unauthorized) persons away while using machine.
2. This machine is suitable for process and environmental conditions as stated in section "Specifications and Tolerances" of this manual only. Any other use is not authorized by Javo BV and this allows the operator and / or the environment at risk.
3. It is prohibited to modify this machine, without prior written approval of Javo BV.
4. Thermal fuses and torque limiters may not be set different upon delivery of the new machine. The thermal circuit breakers should never be used to turn on / off the machine.
5. This machine should be installed so that there is sufficient space remaining for providing safe instructions and / or performing maintenance and / or inspections. Put the brakes on the castors before the machine is turned on.
6. Keep the work area clean and well lit. Cluttered or dark areas invite accidents.
7. This machine is not suitable to be used outside. Electrical components are only splash proof. Keep the machine away from rain and moisture. When using the machine in a humid environment is unavoidable, you should use an RCD.
8. Keep hands, hair, loose clothing and / or jewellery away from moving parts of the machine. Wear appropriate clothing without loose parts. Wear non-slip work shoes.
9. As long as the machine is on, no connection or safety devices may be removed. The machine may only be used when all protective devices and safety-related facilities are available and ready for use.
10. Do not stand on the machine when it is operating.
11. Never move the machine if the power cable and / or pneumatic supply is still connected.
12. Prescribed checks and maintenance in the user manual must be observed.
13. Allow the machine to be serviced and repaired by qualified personnel only with original replacement parts.
14. In addition to the user manual, generally applicable statutory and other regulations regarding accident prevention and environmental protection have to be respected. This is also referred to handling of personal protective equipment.
15. Inform operating personnel before start maintenance. Interrupt if possible the power (mains), before start machine investigation or maintenance by turning off the main switch and locking the main switch. Pull the plug from the wall socket.
  - a. As work must be done with power supply (mains) voltage on the machine, then arrange an additional person who can operate the emergency stop.
16. When a machine part is damaged or not working in the prescribed manner, the work must be interrupted immediately. Resumption allowed only when the machine part is repaired or replaced and checked. Consult your dealer if the machine is not functioning properly.
17. Machine and / or parts must be disposed in accordance with local laws and regulations.

## 2.2 Safety devices on the machine



Caps and doors are screening moving parts. Always place back caps and close doors before the machine is turned on. Caps and doors should remain closed while operating the machine.

The motors of the machine are protected against overload by thermal switches. These switches are located in the control box.

## 2.3 Explanation of icons and symbols

Pictogram	Meaning
	Read and understand this manual before using the machine and / or performing maintenance.
	Remove Power (mains).
	Wear during all work on or with the machine safety shoes and safety glasses.
	Wear during cleaning and maintenance work on this machine also safety gloves and protective clothing.
	Warning. Important points and / or instructions regarding safety and / or injury prevention are marked with this warning sign.
	Dangerous electrical voltage. Dangerous electrical voltage present.
	Risk of crushing. Danger of moving or rotating parts.
	It is forbidden to wear Loose clothing, long hair and / or jewellery nearby moving parts of the machine.
	Trespassing.
	Do not rinse control cabinet Danger of moisture in the cabinet when it is rinsed with water.

Symbols that may be present on this machine			
Drill 	Direction of movement 	Speed ground feeder (curved) 	Speed ground feeder (straight) 
Speed pot belt (curved) 	Speed pot belt (straight) 	Brush disc Rotofill 	Tray belt Rotofill 
Rotor Rotofill 			

### 3 Description of the machine

#### 3.1 Machine overview

- A. Substrate bin
- B. paddlewheel
- C. Drill
- D. Pottrack
- E. Pot erector
- F. Conveyor (optional)

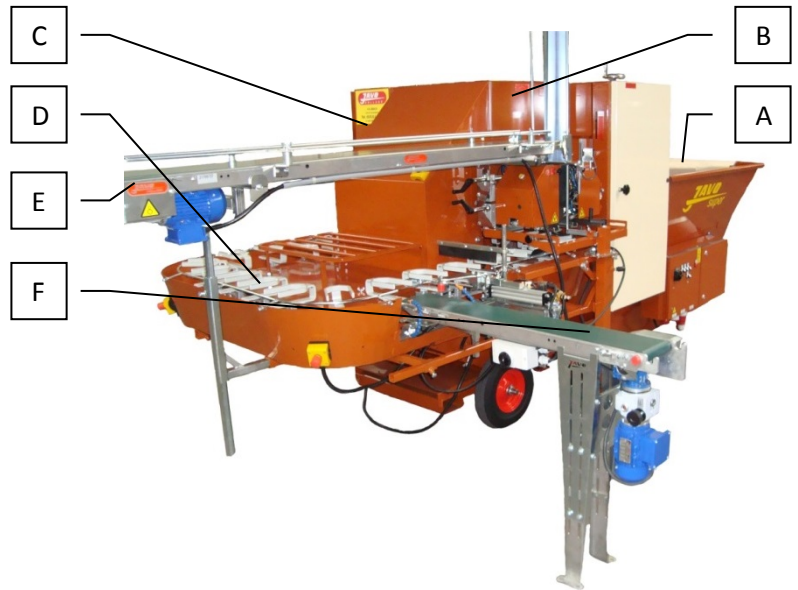

#### 3.2 Outline drawing with main dimensions

Super:

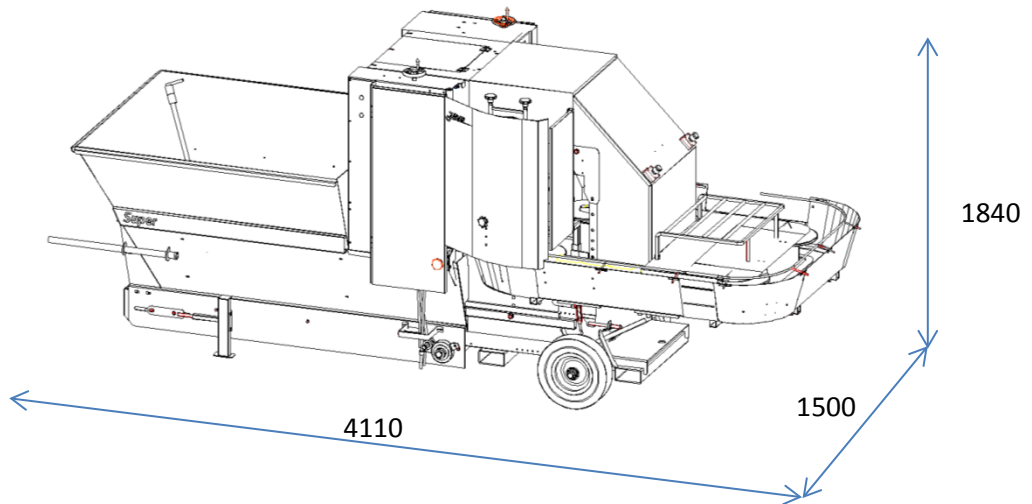

Super Mega:

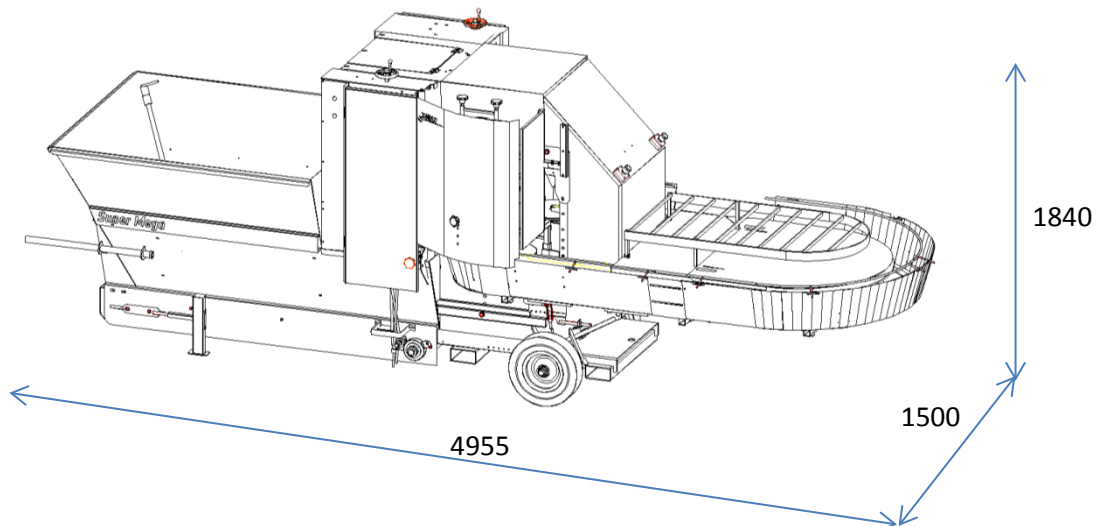



### 3.3 Options

Depending on the intensity of use and customer requirements, this machine can be equipped with various options. Contact your sales consultant.

Options	Code	Specifications
4 meter 5x1.5 cable incl. 16A plug	900965	
Continuous socket	900966	Nonstandard
Pulley with fan belt		Several pulleys with strings for different speeds possible
Number of potholders Super		24 distance between pots 200; 16 distance between pots 300
Number of potholders Super-Mega		30 distance between pots 200; 20 distance between pots 300
Pottrack extension		See separate list of options
Mesh pottrack chain		200mm/24h max. 19cm. 300mm/16h max. 29cm.
Drill breaker	BO1	* See notes.
Outlet double behind each other	AFLPDR	Max dimension: 200=12cm 250/300=14cm
Outlet double next to each other		Max dimension: 200=2x9cm_250=2x12cm_300=2x14cm
Double drilling rig	ST100-3	Mesh from 60 to 150mm
Substrate bin increasement	SU1G	1390 Litre extra
Osmocote dispenser	ST90-13	
Brush Unit after drilling	BM 201	
Brush Unit before drilling	BM 204	
Pressure roller with motor	201-500-01-02	Electrical speed adjustment
Heavy air wheels front	SU1L	
Heavy air wheels with triangle rear	SU1ZL	Wider than substrate bin (no rotator possible)
Solid wheels with brakes rear	SU1ZM	no triangle
Electrical speed adjustment on elevator	SU1E**	Min. Speed min 25% max. Speed plus 20%
Electrical speed adjustment on pottrack	SU1E**	Min. Speed min 25% max. speed plus 20%
Height exit conveyor		825mm or 780mm.
Drill rod spacers	201-423	Required from drill size 16cm
Large drill hood	204-5032	Required from drill size 16cm
Drill bush (motor axis 19mm)		Drill axis 19mm (From drill 16cm)
1000 revolutions drill motor (motor axis 24mm)		1,1 KW. Use for large drills.
Drill bush (motor axis 24mm)		Drill axis 14mm (upto drill 15cm)
Drill bush (motor axis 24mm)		Drill axis 19mm (from drill 16cm up)

\*\*Operation on electrical cabinet.

Using 1000 rpm drill motor is recommended for large drills for big plants.

Air consumption at 3000 strokes / hour, LPO, Cylinder 32-200, 1 set controlled blowers: 250NL / min.

Ask your dealer for advice on options.

Pottrack extensions Super (option)

Number of holders per chain.

Mesh												
200		27	28	29	30	32	33	34		36	39	
250				23				27	28		31	
300	17	18			20		22			24	26	28
Pottrack extension in mm	150	305	410	510	610	815	915	1015	1140	1220	1525	1830

For a Super with a mesh of 200, the centre of the 1st potholder is at 100 mm behind the paddlewheel housing. (Note that this distance is reduced at the wear of the chain).

Pottrack extensions Super Mega (option)

Number of holders per chain.

Mesh											
200		33	34	35	36	38	39	40	42	45	
250				28				32	34	36	
300	21	22			24		26		28	30	32
Pottrack extension in mm	150	305	410	510	610	815	915	1015	1220	1525	1830

### **3.4 Operation**

The Javo Super / Super-Mega is intended to be used for filling pots automatically with substrate only. The filled pots are then drilled with a hole, in which a plant can be placed (on the pottrack or exit conveyor).

The process of the machine starts with the soilbin, which is filled with substrate. By using the soil conveyor belt and return belt, the soil is transferred to the paddlewheel.

The paddlewheel takes over the soil and transfers it onto pots, which have been placed on the pottrack. The pottrack is adjustable in height and width so that it is applicable to different pot sizes.

The pottrack move the pots to the drill which makes holes in the ground. The hole depth and diameter are adjustable. After making a drill hole, the pots are transferred over the pottrack to a conveyor belt.

The machine is equipped with 2 wheels and two fixed supports.

### **3.5 Machine workstations**

This machine has operator places at the pottrack.

### 3.6 Controls

The motor is controlled with the control panel. The control panel consists of the following buttons;

- A. Stop button
- B. Start button
- C. Reset button
- D. Emergency stop button

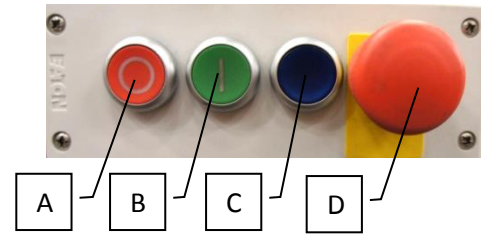

At the electrical cabinet of the machine, these buttons and connectors are placed:

- A. Drill off / on
- B. Pottrack off / on
- C. Paddlewheel off / on
- D. Stopped / Error indication
- E. Main switch
- F. Dispenser continuous / not continuous
- G. Timer off / on
- H. Substrate conveyor off / on
- I. Continuous power IN
- J. Switched power OUT (Max 6A)
- K. Continuous power OUT (Max 6A)

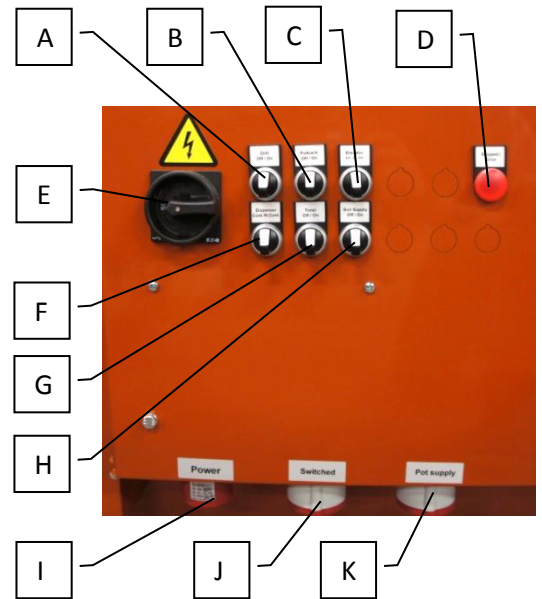

The pottrack chain and paddlewheel can be controlled by frequency converters, which control the speed of motors.

The potentiometers are mounted on a control panel:

- Frequency inverter pottrack chain
- Frequency inverter paddlewheel

Information about inverters is added to this manual separately.

## 4 Transport



*Follow all instructions described in this manual, in particular chapter safety.*

On delivery of the machine, a Javo mechanical engineer must be present to unload the machine from the (freight) wagon.

Prior to moving the machine, the power should be disconnected. Make sure the cables are stowed sufficiently.

When moving within the company (when the machine does not need to be lifted) the state of the machine should be checked. Make sure the path to be traveled is free, so the machine can be moved to the desired position without obstacles.

If the machine is to be lifted for movement (outside the company), please contact your dealer or contact a professional shipping company.

The machine must be transported upright. The relative humidity should not be too high so that water condenses in the machine.

Report damage during or immediately after delivery to the transport company and to Javo BV. Take all necessary steps to prevent further damage.

## 5 Mounting, installation and commissioning



*Follow all instructions described in this manual, in particular chapter safety.*



*This machine is CE marked. When placing multiple machines in one line, the entire line must be properly CE marked before using this machine. Up to CE Marking of the line, commissioning of this machine is prohibited.*

### 5.1 Placement

The machine must be placed on a flat surface, with sufficient weight capacity. Install the machine so that there is enough space left for service providing, safe instructions and / or cleaning, maintenance and / or inspections. Put the brakes on the castors before the machine is turned on.



*This machine is not suitable to be used in the open air. Electrical components are only splashproof. Keep the machine away from rain and moisture. When using the machine in a humid location is unavoidable, you should use an RCD.*

### 5.2 Facilities to take care of by the user

Prior to delivery of the machine, the required materials and facilities (air, power, substrate, etc.) needs to be present within 3 meters of machine.

Required power supply: 400 Volt, 3 Phase + Neutral + Earth. (N. America: 208/220V 60Hz.).

### 5.3 Mounting / Connecting

If applicable, the components supplied are to be mounted on the machine. Make sure that the moving parts are free. If the machine is complete, it can be connected (by a competent person) to the power supply.



*Keep hands, hair, loose clothing and / or jewellery away from moving parts of the machine. Wear appropriate clothing without loose parts. Wear non-slip work shoes.*



*As long as the machine is on, no connection or safety devices may be removed. The machine may only be used when all protective devices and safety-related facilities are available and ready for use.*

## 5.4 Check rotation direction



*Check the rotation direction of the paddlewheel before you start working with the machine.*

Procedure:

1. Connect the power cable.
2. Start the paddlewheel.
  - a. Turn off the main switch.
  - b. Press the reset button emergency stop circuit.
  - c. Start the paddlewheel with the paddlewheel button.
3. Check the direction of rotation of the paddlewheel.
4. Stop the paddlewheel by turning the paddle wheel switch button off.
5. Switch to main switch off.
6. When rotation direction is incorrect:
  - a. Remove the plug from the socket.
  - b. Open the plug and switch 2 of the 3 phases in the plug. This should only be carried out by suitably qualified personnel.

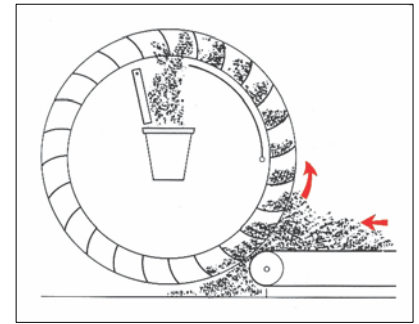

*The rotation direction of the paddlewheel should always be checked after moving (to another wall socket).*

## 5.5 Check drill rotation direction



*Check the rotation direction of the drill before you start working with the machine.*

Procedure:

1. Connect the power cable.
2. Start the drill.
  - a. Turn on the main switch.
  - b. Press the reset button emergency stop circuit.
  - c. Start the drill with the drill button.
3. Check the direction of rotation of the drill.
  - a. The desired rotation direction is shown in this picture.
4. Stop the drill by turning the drill switch off.
5. Switch off the main switch.
6. When rotation direction is incorrect:
  - a. Remove the plug from the socket.
  - b. Open the plug and switch 2 of the 3 phases in the plug. This should only be carried out by suitably qualified personnel.

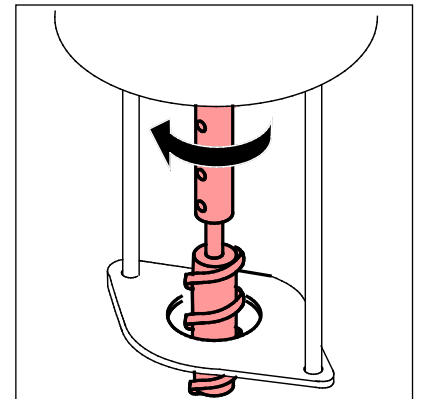

*The rotation direction of the drill should always be checked after moving (to another wall socket).*

## 5.6 Center the drill



Check the centring of the drill before you start working with the machine.

Procedure:

1. Make sure that the centering of the drill is correct. Center the drill in such a way that the hole is drilled in the desired position of the pot.
2. If the alignment is incorrect:
  - a. Adjusting transverse:
    - i. Loosen clamp (A) and slide the drill motor in the right direction..
  - b. Depth Adjustment:
    - i. Loosen clamp bolt (B) and push the drill motor up / down.
  - c. Adjusting angular:
    - i. Loosen clamp (C) and slide the drill motor in the right direction.

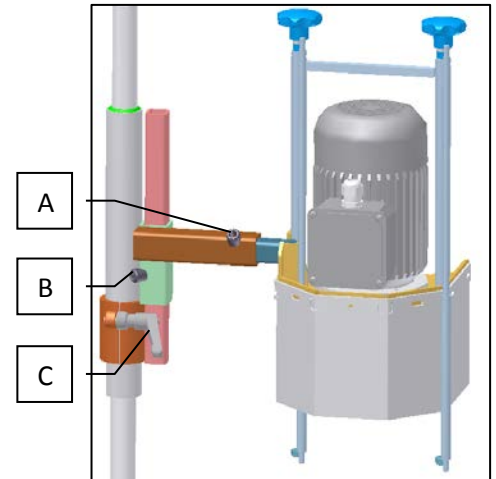

## 5.7 Set drillsize



Set the drillsize before you start working with the machine.

The drill size depends on the plug size of the plants.

Drill (B) is mounted in the drillshaft of the drillmotor with two screws (A). The drillshaft screws have to be mounted to the flat side of the drill sleeve.

Drill plate (C) has a drill hole with a diameter of approximately 10 mm larger than the drill. This drill plate is to be mounted to the bottomsides of rods (D) with 2 locknuts.

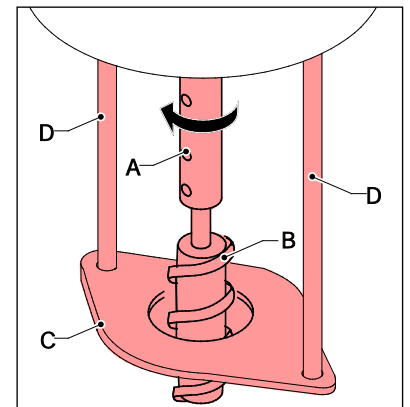

The depth of the hole depends on the position of the drill, which is adjustable. Adjust the depth by placing drill (B) in drillshaft (A).



Recommended distance of drill point under the drill plate is 1-2.cm.

## 5.8 Check substrate conveyor tension



Check the substrate conveyor belt tension before you start working with the machine.

Procedure:

1. Check the substrate conveyor belt tension. The correct tension is obtained when the belt in the middle deflects  $\pm 40$ mm.
2. Adjust the belt tension if necessary .
  - a. Loosen the four screws (B) to the block bearings.
  - b. The tension can be adjusted by simultaneously turning both sides of the ground belt (A).
  - c. Tighten the four screws (B) to the block bearings.

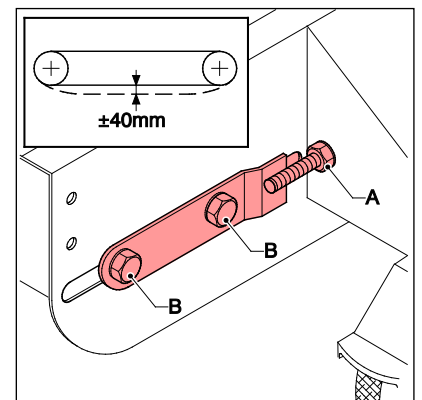



## 5.9 Check pottrack chain tension



Check the pottrack chain tension before you start working with the machine.

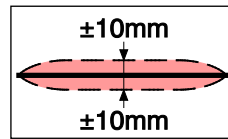

Procedure:

1. Check the chain tension of the pottrack. The correct tension is obtained when the chain can move  $\pm 10\text{mm}$  in the middle.
2. If necessary, adjust the chain tension.
  - a. The tension can be adjusted by two bolts (A), at the front of the pottrack.
  - b. When the pottrack is adjusted, the cover plate (B) needs to be slid into the correct position so that it is in line and close to the chain.

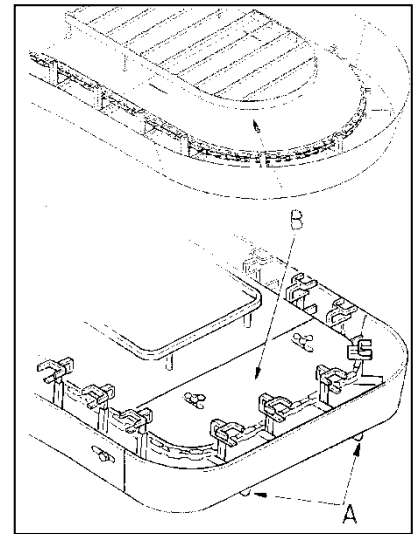

The tension of the chain should not be too tight.

## 5.10 Check paddlewheel belts tension



Check the paddlewheel belts tension before you start working with the machine.

Procedure:

1. Check the paddlewheel belts tension. There should be approximately 2 mm clearance between the rollers and the paddlewheel.
2. If necessary, adjust the belts tension. The tension can be adjusted by the two tightening nuts, located on both sides of the paddlewheel housing under the pottrack.
  - a. Loosen nut (A) and tighten the nuts (B) on both sides equally.
  - b. Tighten nut (A).



The tension of the belts should not be too tight.

### 5.11 Set the substrate conveyor speed



*Set the substrate conveyor speed before you start working with the machine.*

Procedure:

1. Check the substrate conveyor speed. Set the substrate conveyor in such a way that the pots filled sufficiently before they reach the scraper.

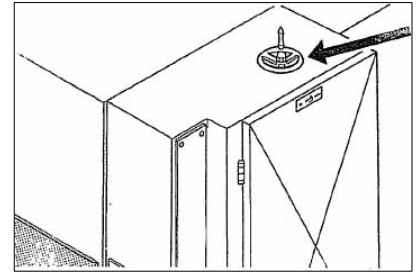

*Adjust the speed of the substrate conveyor as slowly as possible. Enter no more substrate than necessary.*



*Only adjust the substrate conveyor speed when the motors are running.*

2. When the speed needs to be adjusted:
  - a. Turn wheel:
    - i. CCW = the speed of the conveyor is increased.
    - ii. Clockwise = conveyor belt running slower.

### 5.12 Set pottrack speed



*Set the pottrack speed before you start working with the machine.*

Procedure:

1. Check the pottrack conveyor speed. Set the pottrack conveyor in such a way that the pots filled sufficiently before they reach the scraper.



*Only adjust the pottrack speed when the motors are running.*

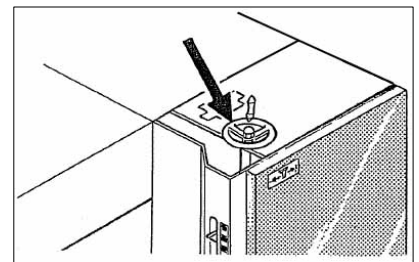

3. When the speed needs to be adjusted:
  - a. Loosen clamp.
  - b. Turn wheel:
    - i. CCW = pottrack is running slower
    - ii. Clockwise = the speed is increased.
  - c. Tighten clamp, after setting the desired speed.

### 5.13 Changeover potholders



*Before operating the machine Assemble the correct potholders.*



*The machine must be turned off before exchanging potholders.*

Procedure:

1. Stop the machine.
2. Remove potholders that are accessible from the operator position.
3. Start the machine, start the pottrack for a few tact's and stop the machine.
4. Remove the remaining potholders.
5. Set all settings to the highest setting.



*Drilling unit + Brush + scraper should be in the highest position. Make sure the pottrack can be started; the pottrack should be able to run free of obstacles.*

6. Set the outfeed arm at the smallest potsize.
7. Install new potholders with the machine switched off.
8. Start the machine, start the pottrack for a few tact's and stop the machine.
9. Place the remaining potholders with the machine switched off.
10. Adjust all settings for the new potholders.



*There are several potholders available.*

### 5.14 Set scraper height



*Set the scraper height before you start working with the machine.*

The scraper controls the amount of substrate on top of the pot.

Procedure:

1. Loosen clamp (A).
2. Set scraper (B) by moving it up or down.
  - a. Wiper up → firmer substrate in the pot.
  - b. Wiper down → loosened substrate in the pot

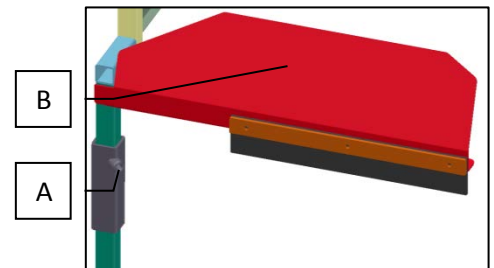

*Drilling unit + Brush + scraper should be in the highest position. Make sure the pottrack can be started; the pottrack should be able to run free of obstacles.*

## 5.15 Set the funnel



*Set the funnel before you start working with the machine.*

The funnel is positioning the substrate in the pot.

Procedure:

1. Both funnel parts can be set independently from each other. Loosen screws (A).
  - a. Position adjustment for two pots in a row:
    - i. 1 funnel upwards;
    - ii. 1 funnel down.



## 6 Operation



Follow all instructions described in this manual, in particular chapter safety.



Keep hands, hair, loose clothing and / or jewelry away from moving parts of the machine. Wear appropriate clothing without loose parts. Wear non-slip work shoes.



As long as the machine is on, no connection or safety devices may be removed. The machine may only be used when all protective devices and safety-related facilities are available and ready for use.



If a machine part is damaged or not working in the prescribed manner, work must be interrupted immediately. Resumption allowed only when the machine part is repaired or replaced and checked. Consult your dealer if the machine is not functioning properly.

### 6.1 Start

Start procedure:

1. Turn on the main power at the electrical cabinet (E).
2. Turn on the drill, potttrack and paddlewheel with switches (F+G+H) at the electrical cabinet.

3. Press the blue reset button (C).
4. Press the green button (B) on the control panel to start the machine.

### 6.2 Stop

Stop procedure:

1. Press the red stop button (A) on the control panel.

### 6.3 Emergency stop

Emergency stop procedure:

1. Press the red emergency stop button on the machine to activate the emergency stop.

Restart after emergency stop procedure:

1. Ensure that the cause of the emergency is resolved.
2. Close all doors and covers.
3. Pull the red emergency stop button to reset.
4. Press the reset button.
5. Press the green button on the control panel to start the machine.

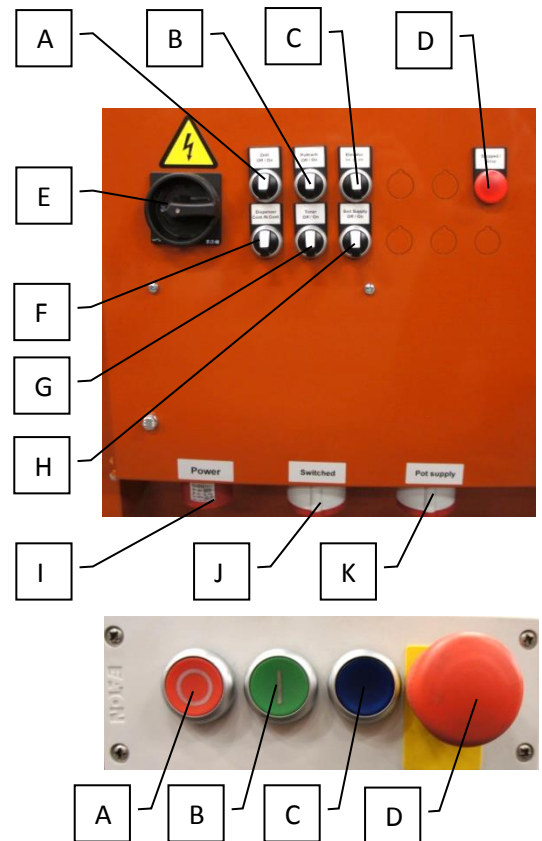

## 7 Maintenance



Follow all instructions described in this manual, in particular chapter safety.



Maintenance of this machine must be performed in compliance with warnings on the machine and in accordance with the user manual by qualified personnel.



Keep hands, hair, loose clothing and / or jewelry away from moving parts of the machine. Wear appropriate clothing without loose parts. Wear non-slip work shoes.



As long as the machine is on, no connection or safety devices may be removed. The machine may only be used when all protective devices and safety-related facilities are available and ready for use.



Always unplug the plug from the socket before starting maintenance. Wear personal protective equipment (see section 2.3).



Inform operating personnel before start maintenance. Interrupt if possible the power (mains), before the machine is investigated or maintained by turning off the main switch and locking it and pull the plug from the socket. If work must be done with power supply (mains) voltage on the machine, work with an additional person who can operate the emergency stop.

### 7.1 Required tools and equipment

A set of keys is included with the machine, consisting of:

- A. Allan key 4 mm
- B. Door key
- C. Spanner 24-27mm
- D. Spanner 17-19mm
- E. Spanner 10-13mm

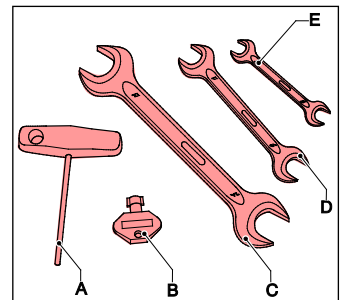

### 7.2 Preventive Maintenance

For the following maintenance instructions normal use is considered. With heavy use, or use under extreme conditions, maintenance should be performed at shorter intervals.

Item	1x per...	Comments
Machine	Day	Check that moving parts are functioning properly and not stuck and / or broken parts or damaged in such a way that the operation is adversely affected. Have damaged parts repaired for use.
Chains and belts	Day	Check tension. See section "Mounting, installation and commissioning".
Substrate bin	Day	Clean the machine daily when using clay or aggressive / sticky substrate. See the section "Empty substrate bin".
Safety components	Week	Test the safety circuit. See section "Test safety circuit".
Pictograms	Week	Check readability and replace if necessary.
Drill unit	40 hours	Lubricate. see section "Lubricate drill unit".
Paddlewheel	Month	Cleaning. See section "paddlewheel cleaning".
Drill shaft	Month	Clean with benzine.
Drill Rods / adjustable drill spindle	Month	Spray with oil.
Pottrack chain	Month	Injecting oil (WD40).
Electrical installation	Year	Check for damage.
Electric motors	Year	Remove dust.

### 7.3 Paddlewheel cleaning

Procedure:

1. Turn off the machine and remove plug from socket.
2. Open cover A with the key provided.
3. Clean the blades with compressed air or a dry brush.
4. Install the protective cover on the machine.

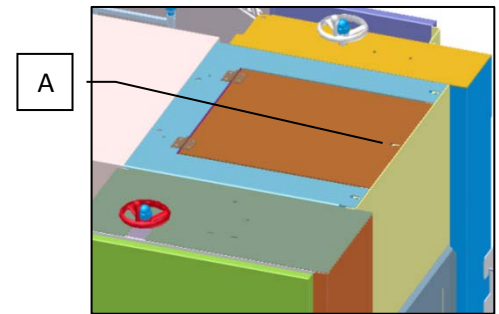

### 7.4 Empty substrate bin



*Do not use a sharp tool, in order to prevent damage to the tire. Do not clean with water.*

Procedure:

1. Turn the machine off and remove cover (A).
2. Turn paddlewheel until the bin is empty.
3. Turn off the machine and remove plug from socket.
4. Remove substrate residues from the paddlewheel housing.

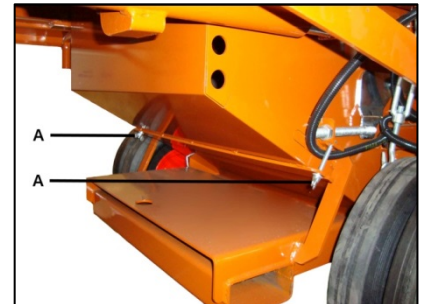

### 7.5 Test safety circuit

Procedure:

1. Start the machine.
2. Press the emergency stop button. The machine is now disabled.
3. Pull the Emergency Stop button. The machine remains off.
4. Press the reset button emergency stop circuit. All possibly connected conveyors start moving.
5. Start the machine



*The machine must not be used when going through the above process, the machine responds differently than described above. Warn directly Javo BV.*

### 7.6 Lubrication drill unit

Procedure:

1. Lubricate the drill arm of the drilling unit with thin grease after every 40 hours.
2. Clean the two chromed shafts of the drilling unit with a mild liquid after every 320 hours of operation.
3. Spray the drill rods with light oil after every 320 hours of operation.



## 7.7 Fault list

Problem	Possible cause	Action / Solution
Motor fault	mains voltage deviates more than 10% of the rated motor voltage	Provide the correct voltage
	Too high cooling air temperature	Provide cool air
	Poor cable connection	check the cable connection and repair if necessary
	Blown fuse	Replace fuse
	Drilling cable broken	Replace drilling cable
	Too little cooling air caused by a clogged cooling air passage	Ensure proper inlet and outlet of the cooling air
The motor hums and takes too much power	Defect winding	Repair or replace the motor winding
	Loose wire	Lock wire
Fuses are blown or switches turned off	Short circuit in wiring or motor	Rectify the short circuit
	Mechanical blockage of pottrack, elevator or boron	Remove blockages
	Motor is connected incorrectly	Connect the motor correct
The substrate conveyor does not move	The motor or mechanical drive is not functioning	Check motor and drive mechanism
	Substrate conveyor tension is too low (belt slipping)	Reset belt tension
Pottrack is not moving	V-belt slipping	Decrease speed. change over V-belt.
		Align belt drives (pulleys)
		Clean belt drives
	Pottrack pawl skips	Ensure that the pawl moves freely and remove obstructions. See Section 7.8.
Drillmotor stops when drilling	Electrical problem with motor or cable	Call a qualified mechanic
Drillhole is too shallow	Adjustment not OK	Adjust the drill depth
	Power Drill Tang springs is insufficient	replace springs
	Drill column does not slide properly	Lubricate with thin grease.
The paddlewheel does not rotate.	Obstacles in the paddlewheel	Verwijder obstakels
	Substrate sticks in the paddlewheel	Remove frontplate and remove excess substrate from the paddlewheel.



Problem	Possible cause	Action / Solution
Machine does not start	Door safety switch is open	Close door and reset the safety circuit by pressing the reset button
	Emergency stop button is not pulled	Pull Emergency Stop button and reset the safety circuit by pressing the reset button
	Emergency stop button not reset	Reset the safety circuit by pressing the reset button
	Breaker tripped in main cabinet	See why circuit breaker has tripped. Remove obstacles to conveyors. Switch on the machine after solving the problem.
	Cable length too large causing voltage loss	Reduce cable length
	Voltage fluctuations by other devices on the same group that requests power	Ensure the correct voltage. Turn off other devices
	A second machine in line is not ready.	Clear second machine in line.
Amount of soil provided is not enough	Soilslide is set too low.	Set the soil slide higher.
	Soilslide is set too low and a tunnel is build up above the soil conveyor.	Set the soil slide higher.
	belt slipping	Check conveyor tension

## 7.8 Pottrack pawl

Make sure the pawl A can move freely and remove obstacles if necessary.

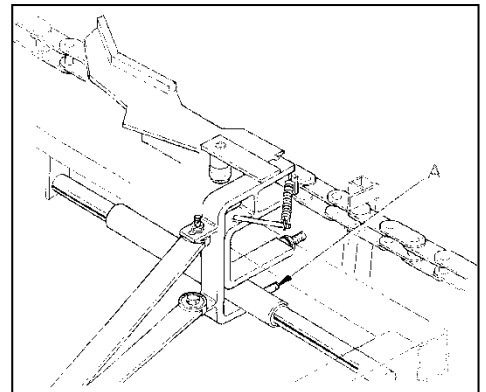

If the pottrack pawl skips, the free stroke of the pawl may be too small. The free stroke is reduced by wear of the chain (because the chain is longer when worn). To increase the free stroke you reassemble the rod which allows for movement of the pawl one hole higher (see photo). This increases the stroke slightly.

Please contact Javo BV.



## 7.9 Drawings and schemes

The drawings accompanying this machine are supplied in a separate file. The wiring diagrams are included in the electrical cabinet of the machine.

## 7.10 Spare parts

Only original spare parts and accessories of Javo BV may be used on the machine.

Javo BV advises you to take certain parts in stock because of wear sensitivity and / or any expected downtime for re-ordering of the parts.

The spare parts list can be found on the assembly drawings. These can be found on JavoNet.

When ordering (spare) parts at Javo BV, the following information must be included: drawing number, item number, desired length (if applicable) and the desired number of pieces.

## 7.11 JavoNet

We recommend you to register your machine on JavoNet. This way you get online access to all technical drawings and documents pertaining to your machine.

Visit our website ([www.javo.eu](http://www.javo.eu)) for more information and to request an account.



## 7.12 Customer support and advice

Our technical department will answer your other questions about repair and maintenance of your machine and spare parts. We can help you with any questions regarding the purchase, use and settings of products and accessories.

## 8 Disposal of machine or machine parts



*Follow all instructions described in this manual, in particular chapter safety.*

Perform the following steps when disposing the machine:

1. Decommission the machine and remove electric and pneumatic power.
2. Drain and remove all consumables.
3. Scrap the machine according to the local legislation.

## 9 EG-conformity statement

EG-conformity statement for machines (directive 2006/42/EG, annex II, under A.)



Javo BV  
 Westeinde 4  
 2211XP Noordwijkerhout  
 The Netherlands

Declares that:

**Machine:**                 *Super / Super Mega*  
**Type:**                    *Potmachine*

is in accordance with the **Machine directive 2006/42/EG** and complies with the provisions of the **EMC-directive 2004/108/EEG**

Complies with the harmonized European Standards:

Harmonized European standard	definition	Harmonized European standard	definition
NEN-EN-ISO 12100:2010	Safety of machinery - Basic concepts, general principles for design - Part 1: Basic terminology, methodology	NPR-ISO/TR 14121-2:2010	Safety of machinery - Risk assessment - Part 2: Practical guidance and examples of methods
NEN-EN-ISO 13857	Safety of machinery - Safety distances to prevent hazard zones being reached by the upper and lower limbs	NEN-EN 13850	Safety of machinery - Emergency stop - Principles for design
NEN-EN-ISO 13849-1	Safety of machinery - Parts of Control Systems with a safety function - Part 1: General principles for design	NEN-EN-IEC 60204-1	Safety of machinery - Electrical equipment of machines - Part 1: General requirements

The Netherlands, Noordwijkerhout,  
 October 2014

Cees Bouwmeester  
 Director