

SEAS - INSTRUCTIONS

- MERCEDES -

Please read the complete document before starting the installation

Brand assignment

SEAS add-on module is delivered NOT PROGRAMMED, therefore a brand (Mercedes in this case) must be set with computer and specific program SETUP TRUCK

This procedure can be achieved both before and after the installation on the vehicle (*if after the installation, the vehicle power batteries must be disconnected during the operations*).

- Connect the programming cable to the USB port of your PC
- Connect the programming cable to the SEAS module by using the white 4 pins connector; during this operation the LED (Light Emission Diode) of the SEAS module will be off.
- Run the program SimulaCan (select it from the list of programs installed on your pc).
- Proceed as follow:

Select "Start"

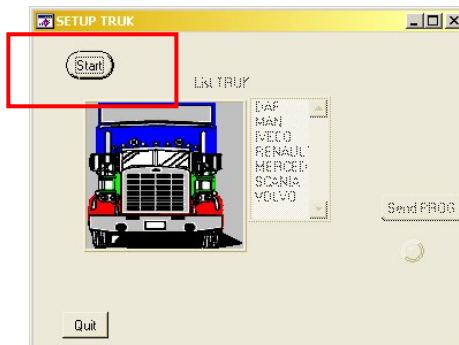

Wait for next screen displayed

(the time required can vary according to the quantity of virtual COM installed)



If the connection is successfully achieved (serial communication recognized and accepted) the program will display this page: you can now select Mercedes brand

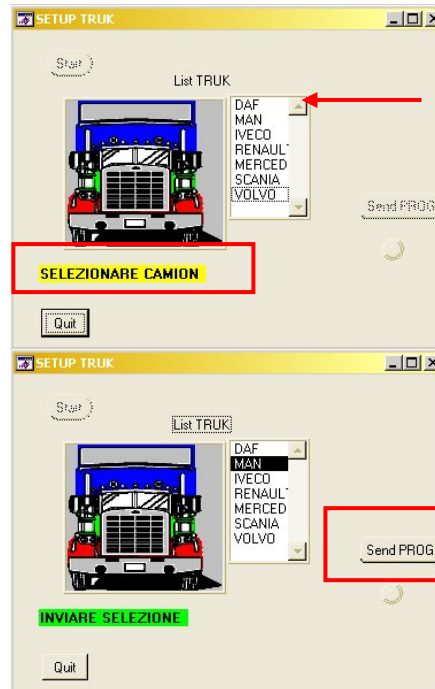

Select "Send PROG"

When the programming operation is completed, the yellow LED on your SEAS module will turn on.

Select "Quit" to close the program SimulaCan

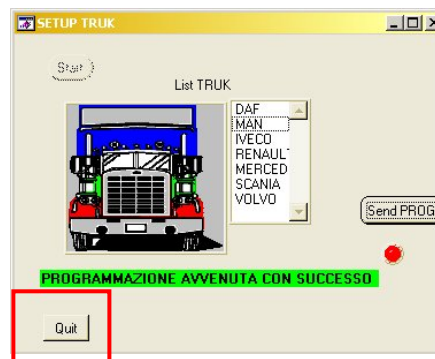

- Disconnect the programming cable of your SEAS module and place the specific cover on top of the white 4 pins connector.

IMPORTANT: the following instructions indicate how to connect and install your SEAS module on the original AdBlue system of the truck.

The number displayed and the colour of the conductors of the AdBlue system are referred to Mercedes Actros or Axor year 2009, these details may vary according to different production lots or vehicle equipment.

Please refer to the schemes/layouts supplied with the Mercedes technical manual to identify the CAN-Bus line of the AdBlue system, its protection fuse and the power feeding.

The main working procedure of SEAS modules does not vary.

Installation on the vehicle:

Before proceeding, please make sure that the following conditions are respected:

- NO faulty codes memorized in the original ECU.
- AdBlue liquid higher than the reserve level
- Vehicle batteries disconnected from the electrical circuit

The SEAS module is supplied with 5 conductors:

- **Power feeding / activation:**

- RED (+15): to be connected to a **24 Volt source “under key”** (24 Volt enabled when the engine key is in ON position); preferably to the same source that enables the AdBlue system working. This connection will supply power to the SEAS module when the engine key is in ON position (dashboard ON).
- BLACK (earth): to be connected to an earth available, preferably the same as AdBlue.
- GREY (+30): to be connected to a **24 Volt source always available** of AdBlue system, **necessarily BETWEEN** the F1 or F11 protection fuse and the AdBlue system.

- **CAN-Bus line connection:**

The two conductors plaited together must be connected to the CAN-Bus line of the AdBlue system.

- WHITE (CAN H): to be connected to CAN H of the system that must be simulated.
- BROWN (CAN L): to be connected to CAN L of the system that must be simulated.

The connections must be made under the dashboard, into the fuse and relay box.

The 5 conductors of SEAS module must be soldered to the 5 conductors of the AdBlue system.

SEAS Module		Mercedes AdBlue system	
Notes	Colour	Notes	Colour
CAN L	BROWN	CAN L	GREY/GREEN
CAN H	WHITE	CAN H	GREY/WHITE
Activation (+30)	GREY	24 Volt always available (+30) between F1 (or F11) and AdBlue	-
24V under key (+15)	RED	24V UNDER KEY (+15)	-
Earth	Black	Earth	-

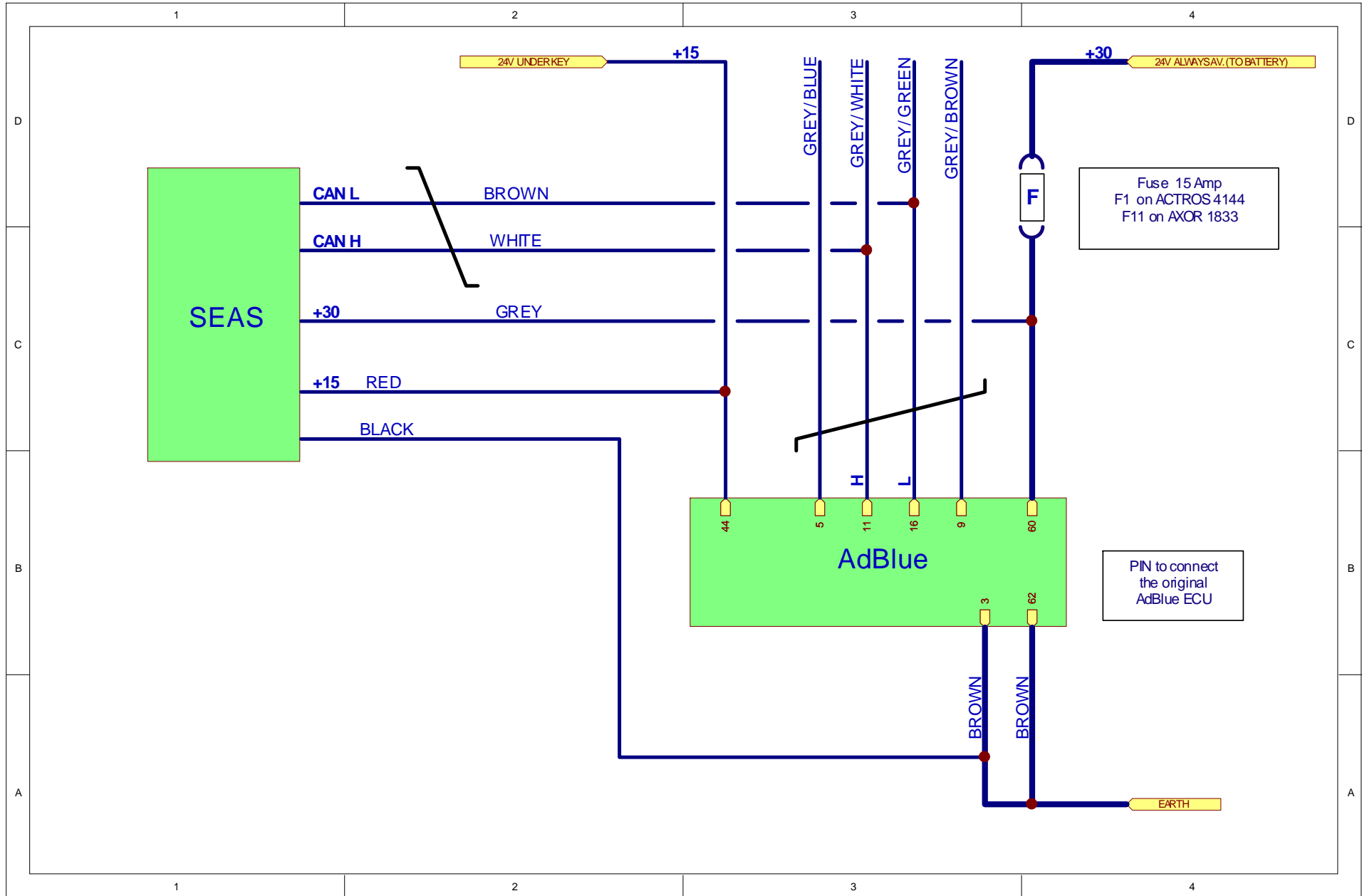

Notes on the “Activation” signal:

The SEAS module and the original AdBlue system cannot be both activated at the same time, the **grey Activation wire (+30)** is utilized to enable automatically the SEAS module working.

For this reason, it is extremely important to connect this wire to a 24 Volt source always available (battery); moreover, the soldering operation must be done between the 15 Amp. (**F1 or F11**) fuse and the AdBlue module.

Consequently, if you want to stop and exclude the original AdBlue system working, it is enough to **remove the F1 (or F11) fuse before starting the engine**. The SEAS module will automatically be activated.

To reset the original AdBlue system working, it is enough to re-install the F1 (or F11) fuse before starting the engine. The SEAS module will be de-activated.

IMPORTANT: the **F1 (or F11)** fuse is located into the fuse & relay box, under the dashboard, passenger side.

It might be identified with a written **SCR**.

- There might be other fuses with the same written **SCR**, but characterized by a lower value of Ampere; these fuses do NOT have to be considered.

Self-learning CAN-Bus line:

Once the SEAS module is fully connected to the electrical circuit of AdBlue system, and after the identification of the F1 (or F11) fuse controlling the power feeding of the AdBlue system, the vehicle power batteries can be reconnected.

The SEAS module acquires inputs from the CAN-Bus line the first time the dashboard is turned on (key ON but engine still OFF).

Please make sure that F1 (or F11) fuse is correctly inserted and placed, then follow the procedure:

- Turn on the dashboard (key ON) and verify that the YELLOW LED is turned on, too.
- After approx. 1 minute, the YELLOW LED. switches off and a GREEN LED will turn on.
- Switch off the dashboard (key OFF).

After this procedure, the SEAS module will be activated whenever the dashboard will be turned on (key ON). The result will be:

- If the **fuse is installed**, the original AdBlue system will be working and the two LED will always be on.
- If the **fuse is not installed**, the original AdBlue system will not be working and the SEAS module will be activated; the two LED will be flashing.

All the operations on the fuse have to be performed ONLY with the dashboard switched off (key OFF).

SEAS module - diagnostic table of LED (Light Emission Diode)			
DASHBOARD	YELLOW LED	GREEN LED	State of the SEAS module
KEY OFF	OFF	OFF	No power feeding
KEY ON	OFF	OFF	Not programmed
	ON	OFF	Programmed, waiting for self-learning
	OFF	ON	Auto-acquiring operations completed
	ON	ON	Data saved: module not activated
	Supply intermittent		Data saved: module ACTIVATED