



TCM 130 Step Code BA
Software API

User Manual V2.04
July 2008

Revision History

The following major modifications and improvements have been made to the initial version of the document (TCM 130 User Manual V1.0):

Version	Subject (major changes since last version)
1.01	Additional note in explanation of setIDBase; Field BUTTONS defined for PTM200
1.02	Remark on interrupts added in chapter 4
1.03	Changes in 3.5 Current consumption
2.00	New functions added in latest release of API: wait(); setSerialSpeed(); setRadioBufferMaturity(); repeater functionality included; number of radio buffers configurable; priority of radio interface over serial interface; buffer size reduced for serial communication; additional return codes for sleep() and initTCM130(); compatible with latest Microchip IDE (V 7.3) and Compiler (V 3.00); correction of current consumption
2.01	Information added in setRxSensitivity()
2.02	Editorial changes
2.03	Return parameter 7 in initTCM() function corrected
2.04	Sensitivity values corrected in setRxSensitivity() function. Timing recommendation changed in sendRadioTelegram() function. Description of on-board switches for EVA110 board modified.

**Published by EnOcean GmbH,
Kolpingring 18a, 82041 Oberhaching**

© EnOcean GmbH
All Rights Reserved

Important!

This information describes the type of component and shall not be considered as assured characteristics. No responsibility is assumed for possible omissions or inaccuracies. Circuitry and specifications are subject to change without notice. For the latest product specifications, refer to the EnOcean website: <http://www.enocean.com>.

As far as patents or other rights of third parties are concerned, liability is only assumed for components, not for applications, processes and circuits implemented within components or assemblies.

EnOcean does not assume responsibility for use of devices described and limits its liability to the replacement of devices determined to be defective due to workmanship. Devices or systems containing RF components must meet the essential requirements of the local legal authorities.

EnOcean GmbH does not recommend the use of its products in life support applications and will not knowingly sell its products for use in such applications unless it receives an adequate "products liability indemnification insurance agreement".

Components of the modules are considered and should be disposed of as hazardous waste. Local government regulations are to be observed.

Packing: Please use the recycling operators known to you. By agreement we will take packing material back if it is sorted. You must bear the costs of transport. For packing material that is returned to us unsorted or that we are not obliged to accept, we shall have to invoice you for any costs incurred.

Table of Contents

1. GENERAL DESCRIPTION	5
1.1 Basic Functionalities.....	5
1.2 Features Overview (based on TCM120 Hardware).....	6
1.3 Physical Dimensions (TCM120 Hardware).....	6
1.4 Environmental Conditions.....	7
1.5 Ordering Information.....	7
2. FUNCTIONAL DESCRIPTION	8
2.1 Block Diagram	8
2.2 Pin Description	8
3. APPLICATIONS INFORMATION.....	9
4. API Description	10
# define _CONFIG.....	10
# define _NR_RX_RADIO_BUFFERS.....	10
# define _NR_TX_RADIO_BUFFERS.....	11
char initTCM130(void).....	11
char sendSerialByte(unsigned char value)	11
char getSerialByte(unsigned char *value).....	11
char sendSerialTelegram(union telegram *telegram).....	12
char getRadioTelegram(union telegram *telegram)	16
char sendRadioTelegram(union telegram *telegram).....	17
char setRadioFilter(unsigned long ID)	17
char setRadioBufferMaturity(unsigned char time)	17
char setSerialSpeed(unsigned char SpeedCode).....	18
char clearRadioFilter().....	18
char setIDBase(unsigned long IDBase).....	18
unsigned long readIDBase().....	19
char setRxSensitivity(unsigned char sensitivity).....	19
char readRxSensitivity().....	19
char sleep(unsigned long time).....	19
char receiverOn().....	20
char receiverOff()	20
char repeaterOn().....	20
char repeaterOff().....	21
void reset().....	21
char writeOut(unsigned char outPin, unsigned char level).....	21
char configInputs(unsigned char configCode)	22
char configSerialPins(unsigned char pinConfigCode).....	22
char readADIn(unsigned char inPin, unsigned char resolution, unsigned int *ADconversion)	22
char readDigitalIn(unsigned char inPin, unsigned char *level)	23
unsigned long getTime()	23
void nop()	23
void wait(unsigned long delay)	23
void clrWdt().....	23
void switchWdtOn().....	24



void switchWdtOff()	24
char writeEeprom(unsigned char eepromAddress, unsigned char data).....	24
char readEeprom(unsigned char eepromAddress, unsigned char *data)	24
Allocation of variables in RAM.....	24
A. Development Tools.....	25
A.1 Microchip Tools	25
A.2 EnOcean Tools.....	26
B. Installation.....	28
C. Sample Applications	29

1. GENERAL DESCRIPTION

The TCM 130 is a software API for the transceiver module TCM 120 of EnOcean. It enables the realization of bi-directional RF applications based on the innovative EnOcean radio technology.

The TCM 120 transceiver module serves the 868 MHz air interface protocol of EnOcean. It receives all signals of the EnOcean radio transmitters (based on e.g. modules PTM 100, STM 100) and makes them available via an API. The API provides several hardware interfaces such as a serial interface, 10bit A/D inputs and digital inputs and digital outputs.

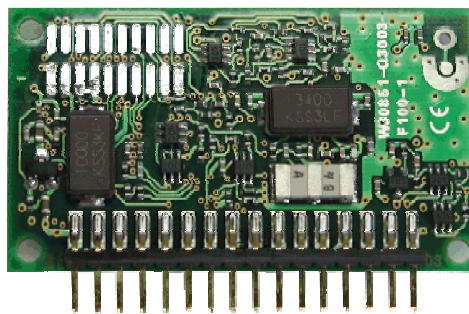

Figure 1: TCM 120 module

1.1 Basic Functionalities

- Receive and transmit EnOcean radio telegrams
 - All different kinds of telegrams (e.g. PTM 100 or STM 100) can be generated
 - The TCM 130 can send on 128 different IDs (derived from 1 base number)
 - Filter functionality
- Serial interface support
- Read analog and digital inputs, write digital outputs
- EEPROM read/write
- Timer functionality
- Various power-down modes



1.2 Features Overview (based on TCM120 Hardware)

Frequency / modulation type / transmission power: .868.3 MHz / ASK / max. 10 mW
Data rate (transmitter) / channel bandwidth (receiver):..... 120 kbps / 280 kHz
Transmission range: 300 m free field
Power supply voltage:5V +10%/-5%
Sleep current without BOD and WDT: typ. $\sim 0.1 \mu\text{A}^1$
Sleep current with WDT on, BOD on/off: typ. $\sim 50\mu\text{A} / 10 \mu\text{A}^1$
Current consumption (receiver on/off): typ. 33 mA (max. 40 mA) / 15 mA¹
Current consumption (receive+transmit): max. 55 mA¹
Bi-directional serial interface:full-duplex, async., 9.6 - 57.6 kbps
Receiver features: sensitivity can be reduced by SW command
Fast power up: <1ms
Fast Tx power up from stand-by:..... $\sim 2 \mu\text{s}$
Tx/Rx changeover: $\sim 0.5 \mu\text{s}$
Inputs: ..up to 5 inputs, configurable as digital or analog input; AD-conversion up to 10bit
Outputs:up to 5 digital outputs
Free Memory: 144 bytes EEPROM, $\sim 16 \text{ kB}$ FLASH, $\sim 0.5 \text{ kB}$ RAM
RSSI Output:..... indicates received peak signal strength

BOD = Brown Out Detector, WDT = Watch Dog Timer

1.3 Physical Dimensions (TCM120 Hardware)

Antenna: No antenna installed, 9 cm whip antenna or external antenna mountable
 only 1 antenna for transmit and receive
Dimensions of PCB: 24.0 x 42.0 x 5 mm (without wiring pins)
Connector: 16 pins, grid 2.0 mm (4.0 mm in length, \square 0.5 mm)

¹ All input pins connected to GND. All other pins except Vcc, and reset pin not connected at the time of measurement. All outputs set to 0

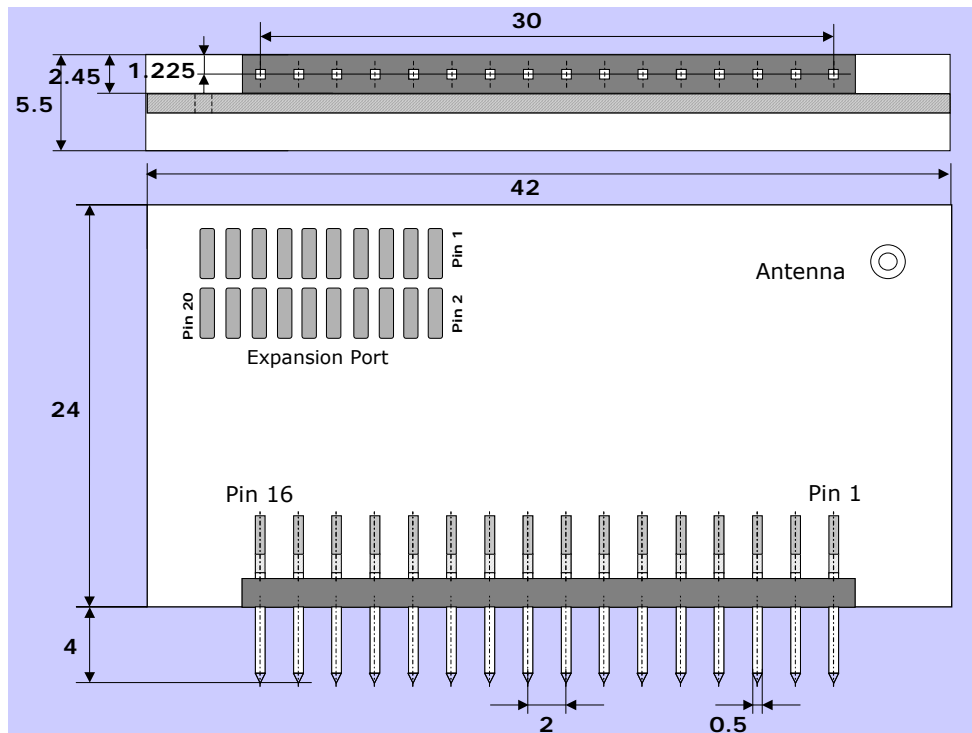

Figure 2: TCM 120 package outlines

1.4 Environmental Conditions

Operating temperature: -25 up to +65 °C

Storage temperature:-40 up to +85 °C, +85 up to +100 °C for 1h max.

Humidity:0 % to 95 % r.h.

1.5 Ordering Information

Type	EnOcean Ordering Code
TCM 120	S3003-K120
TCM 130 Starter Kit	S3004-K130
TCM 130 Library CD-ROM	S3004-K930

Important note: The expansion port connector, which is mounted for development purposes on the modules supplied with the TCM 130 Starter Kit is not mounted on standard TCM 120 modules. In order to program the TCM 120 modules with own software it is necessary to contact the programming pins with needles.

2. FUNCTIONAL DESCRIPTION

2.1 Block Diagram

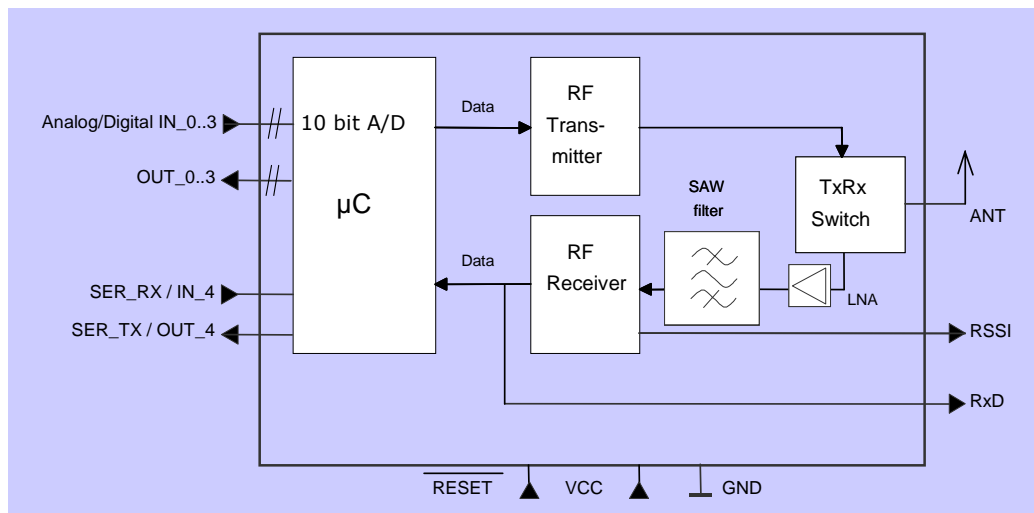

Figure 3: Block diagram of TCM 120

2.2 Pin Description

Main connector:

Pin No.	Symbol	Function	Operational characteristics
1, 16	GND	Ground connection	
2	RESET	External reset signal	
3	IN_0	Digital or analog input	Connect to GND ¹ if not used
4	IN_1	Digital or analog input	Connect to GND ¹ if not used
5	IN_2	Digital or analog input	Connect to GND ¹ if not used
6	IN_3	Digital or analog input	Connect to GND ¹ if not used
7	SER_RX / IN_4	Serial communications reception line	Viewed from TCM 5V CMOS input
8	SER_TX / OUT_4	Serial communications transmission line	Viewed from TCM 5V CMOS output, 20 mA max.
9	OUT_0	Digital output	5V CMOS output, 20 mA max.
10	OUT_1	Digital output	5V CMOS output, 20 mA max.
11	OUT_2	Digital output	5V CMOS output, 20 mA max.
12	OUT_3	Digital output	5V CMOS output, 20 mA max.
13	RxD	Raw base band data from receiver	5V TTL output, source impedance approx. 11 kΩ
14	RSSI	RSSI signal from receiver	Source impedance approx. 20 kΩ
15	Vcc	Supply voltage	5V +10%/-5%, max. 55 mA

¹ To reduce power consumption and for stable conditions

Expansion Port:

Pin No.	Symbol	Function	Operational characteristics
1-11	Reserved	Reserved	
12, 14, 16	Vcc	Supply voltage	5V +10%/-5%, max. 55 mA
13, 15, 17	GND	Ground connection	
18	MCLR/Vpp	Used for programming	
19	ICSP_DATA	Used for programming	
20	ICSP_CLK	Used for programming	

3. APPLICATIONS INFORMATION

Please refer to the TCM120 hardware users manual!

4. API Description

Important remark: Please note that all interrupts are occupied by the API. If interrupts are used the API may not work properly!

define _CONFIG

The first source code line of user application code must contain

```
#define _CONFIG Code
```

Through this define the user configures the watch dog timer (WDT) period and brown-out state. The following table explains the relation between the code and the configuration.

Code	WDT approximate period (ms)	Brown-out state	Brown-out voltage(V)
1	16	ON	4,2
2	128	ON	4,2
3	2048	ON	4,2
4	16	OFF	--
5	128	OFF	--
6	2048	OFF	--

The current consumption is much lower without brown out detector (relevant especially during sleep). For applications using a battery, where fluctuations of the voltage are not expected it may be helpful to switch off the brown out detector and extend battery life. Please note: The WDT period strongly depends on temperature. Please refer to the data sheet of the PIC18F452 micro controller for more details. If not specified _CONFIG 6 is used.

Important note: It may take up to 60ms until the receiver is stable after a *receiverOn()*, *repeaterOn()* or return from *sleep()* command. It may happen that during that time the interrupt routine for receiving is called quite often during that time. In combination with a WDT period of 16ms this may lead to a repeated reset of the module.

define _NR_RX_RADIO_BUFFERS

With this define the number of rx radio buffers is defined:

```
# define _NR_RX_RADIO_BUFFERS NumBuf
```

NumBuf must be between 4 and 10. The default value is 4.

Please note:

- The free RAM size is reduced by increasing the number of radio buffers.
- The number of radio buffers must be defined before *initTCM130()* is executed.

define _NR_TX_RADIO_BUFFERS

With this define the number of tx radio buffers is defined:

```
# define _NR_TX_RADIO_BUFFERS NumBuf
```

NumBuf must be between 1 and 11. The default value is 1.

Please note:

- The free RAM size is reduced by increasing the number of radio buffers.
- The number of radio buffers must be defined before *initTCM130()* is executed.
- If the repeater functionality is used the number of TX radio buffers must be at least the number of RX radio buffers + 1

char initTCM130(void)

This function must be inserted as first line code in the main program. Initializes the internal registers. The startup procedure of the module takes less than 1 ms.

Returns:

- | | |
|---|--|
| 0 | No error. TCM130 correctly initialized |
| 1 | Radio buffer wrong initialized: RX buffer address, amount of RX radio buffer out of specified value. TCM130 not correctly initialized. |
| 2 | Reset happened due to stack overflow |
| 3 | Reset happened due to stack underflow |
| 4 | Reset happened due to Brown-out detection |
| 5 | Reset happened due to watch dog timer overflow |
| 6 | Reset happened due to power-down |
| 7 | Radio buffer wrong initialized: TX buffer address, amount of TX radio buffer out of specified value. TCM130 not correctly initialized. |

char sendSerialByte(unsigned char value)

Send one byte via the serial interface. There is a buffer for 126 bytes.

Returns

- | | |
|---|--|
| 0 | byte sent |
| 1 | byte could not be sent in 20ms |
| 2 | SER_RX/TX configured as digital input/output |

char getSerialByte(unsigned char *value)

If a byte has been received via the serial interface it can be read with the *getSerialByte()* function. There is a buffer for 14 bytes.

Please note: The radio receiver routine has priority over the serial interface. In case of radio communication incoming serial bytes may be lost. An error handling should be provided by the application.

Returns

- | | |
|---|--|
| 0 | byte received |
| 1 | no byte received |
| 2 | SER_RX/TX configured as digital output/input |
| 3 | USART RX buffer overrun |

- 4 Framing error. Maybe due to serial speed mismatch. Will be cleared automatically after correct reception of one byte.
- 11 parameter address not allowed

char sendSerialTelegram(union telegram *telegram)

The function is used to log the content of received or transmitted telegrams via the serial interface or to transmit other information via the serial interface. The information is sent according to the EnOcean serial port protocol. There are several possibilities to address the bytes in this structure as shown below. There is a buffer for 9 telegrams (126 bytes).

Please note: The transmission of a serial telegram takes at least about 15ms. Please take care not to enter sleep mode before the transmission of the previous telegram has been finished.

```
union telegram{
    struct{
        unsigned char type;
        unsigned char org;
        unsigned char data3;
        unsigned char data2;
        unsigned char data1;
        unsigned char data0;
        unsigned char id3;
        unsigned char id2;
        unsigned char id1;
        unsigned char id0;
        unsigned char status;
    };
    struct{
        unsigned char type;
        unsigned char org;
        unsigned char mdata5;
        unsigned char mdata4;
        unsigned char mdata3;
        unsigned char mdata2;
        unsigned char mdata1;
        unsigned char mdata0;
        unsigned char mid1;
        unsigned char mid0;
        unsigned char status;
    };
    struct{
        unsigned char type;
        unsigned char org;
        unsigned char : 8;
        unsigned char : 8;
        unsigned char : 8;
        unsigned char : 8;
        unsigned char : 8;
        unsigned char aid1;
        unsigned char aid0;
        unsigned char : 8;
        unsigned char : 8;
        unsigned char status;
    };
};
```

Returns

0	telegram sent
1	information could not be sent in 20ms
2	SER_RX/TX configured as digital input/output
11	parameter address not allowed

Message format

The following figure shows the message format. A data block of length n is composed of 2 synchronization bytes, 1 octet for the header and n-1 octets for the message data.

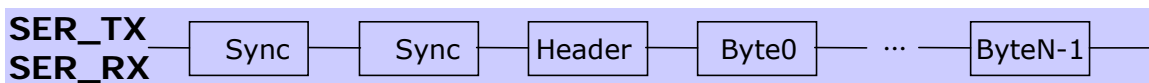

Figure 8: Message format for asynchronous serial communication

Octet signals and bit order

- Default 9.6 kbps, 8 data bits, no parity bit, one start bit, one stop bit
- Line idle is binary 1 (standard)
- Each character has one start bit (binary 0), 8 information bits (least significant bit first) and one stop bit (binary 1)

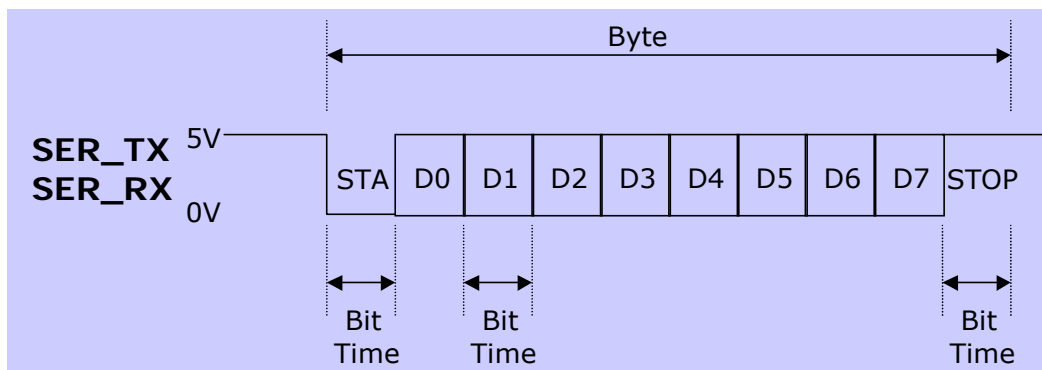

Figure 9: Signals and bit order sending a byte

General encoding	Encoding for RPS, 1BS, 4BS, HRC	Encoding for 6DT	Encoding for MDA
0xA5 (sync byte)	0xA5 (sync byte)	0xA5 (sync byte)	0xA5 (sync byte)
0x5A (sync byte)	0x5A (sync byte)	0x5A (sync byte)	0x5A (sync byte)
type	0x0B (TX_TELEGRAM) ² 0x6B (RX_TELEGRAM)	0x0B (TX_TELEGRAM) 0x6B (RX_TELEGRAM)	0x0B (TX_TELEGRAM) 0x6B (RX_TELEGRAM)
org	org	0x0A	0x0B
data3	data3	mdata5	0xXX
data2	data2	mdata4	0xXX
data1	data1	mdata3	0xXX
data0	data0	mdata2	0xXX
id3	id3	mdata1	aid1
id2	id2	mdata0	aid0
id1	id1	mid1	0xXX
id0	id0	mid0	0xXX
status	status	status	status
ChkSum	ChkSum	ChkSum	ChkSum

Remarks

- type: value 0x0B, and 0x6B may be used, other values reserved for future
- data2 = data1 = data0 = 0x00 for RPS,1BS, HRC

Detailed description of ORG field

ORG	Description	RRT / TRT Acronym
0x05	Telegram from a PTM switch module received (original or repeated message)	RPS
0x06	1 byte data telegram from a STM sensor module received	1BS
0x07	4 byte data telegram from a STM sensor module received	4BS
0x08	Telegram from a CTM module received	HRC
0x0A	6byte Modem Telegram	6DT
0x0B	Modem acknowledge telegram	MDA

Description of data0..3 and id0..3

If ORG = 0x05 and NU = 1 (N-message from a PTM switch module)

id3..0 32bit transmitter ID
data2..0 always = 0
data3 as follows:

7	0
RID	SA

RID	(2 bit)	Rocker ID, from left (A) to right (D): 0, 1, 2 and 3 (decimal)
UD	(1 bit)	UD=1 → O-button, UD=0 → I-button
PR	(1 bit)	PR=1 → Button pressed, PR=0 → Button released
SRID	(2 bit)	Second Rocker ID, from left to right: 0, 1, 2 and 3
SUD	(1 bit)	(Second) SUD=1 → Up button, SUD=0 → Down button
SA	(1 bit)	SA=1 → Second action, SA=0 → No second action

² viewed from TCM module

If *ORG* = 0x05 and *NU* = 0 (U-message from a PTM switch module)

id3..0 32bit transmitter ID
 data2..0 always = 0
 data3 as follows:

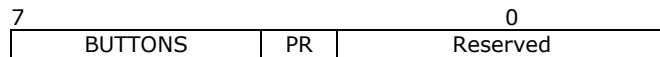

BUTTONS (3 bit) Number of simultaneously pressed buttons, as following:

PTM 100 (Type1):	PTM200 (Type2):
0 = 0 Buttons	0 = 0 Button
1 = 2 Buttons	1 = not possible
2 = 3 Buttons	2 = not possible
3 = 4 Buttons	3 = 3 or 4 buttons
4 = 5 Buttons	4 = not possible
5 = 6 Buttons	5 = not possible
6 = 7 Buttons	6 = not possible
7 = 8 Buttons	7 = not possible

PR (1 bit) PR = 1 → Button pressed, PR = 0 → Button released
Reserved (4 bit) for future use

If *ORG* = 0x06 (Telegram from a 1 Byte STM sensor)

id3..0 32bit transmitter ID
 data2..0 always = 0
 data3 Sensor data byte

If *ORG* = 0x07 (Telegram from a 4 Byte STM sensor)

id3..0 32bit transmitter ID
 data3 Value of third sensor analog input
 data2 Value of second sensor analog input
 data1 Value of first sensor analog input
 data0 Sensor digital inputs as follows:

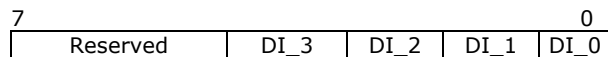

If *ORG* = 0x08 (Telegram from a CTM module set into HRC operation)

id3..0 32bit transmitter ID
 data2..0 always = 0
 data3 as follows:

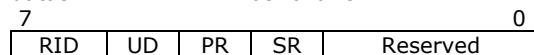

RID (2 bit) Rocker ID, from left (A) to right (D): 0, 1, 2 and 3
UD (1 bit) UD=1 → O-button, UD=0 → I-button
PR (1 bit) PR=1 → Button pushed, PR=0 → Button released
SR (1 bit) SR=1 → Store, SR=0 → Recall (see note)
Reserved (3 bit) for future use

Note: The bit SR is used only when the lower 3 Bits from id0 = B'111' (scene switch), and RID ≠ 0 (indicates that the memory buttons M0-M6 are operated in the handheld remote control).

Description of mdata0..5 and mid0..1

If *ORG* = 0x0A (Modem telegram)

Please note the different structure of modem telegrams with 6 data bytes (mdata0..5) and 2 address bytes (mid0..1) for the address of the receiving modem.

Description of aid0..1

If ORG = 0x0B (Modem Acknowledge telegram)

Please note the different structure of modem acknowledge telegrams with 2 address bytes (aid0..1) for the address of the answering modem.

Detailed description of STATUS field

If ORG = 0x05 (Telegram from a PTM switch module)

7	0
Reserved	T21 NU RP_COUNTER

Reserved	(2 bit)	for future use
T21	(1 bit)	T21=0 → PTM switch module of type 1, T21=1 → PTM switch module of type 2
NU	(1 bit)	NU=1 → N-message, NU=0 → U-message.
RP_COUNTER	(4 bit) =0..15	Repeater level: 0 is original message (not repeated)

PTM switch modules of Type 1 (e.g. PTM 100) do not support interpretation of operating more than one rocker at the same time:

- N-message received → Only one pushbutton was pressed.
- U-message received → No pushbutton was pressed when activating the energy generator, or more than one pushbutton was pressed.

PTM switch modules of Type 2 allow interpretation of operating two buttons simultaneously:

- N-message received → Only one or two pushbuttons have been pressed.
- U-message received → No pushbutton was pressed when activating the energy generator, or more than two pushbuttons have been pressed.

Note for telegrams from PTM 100 piezo transmitters: Due to the mechanical hysteresis of the piezo energy bow, in most rocker switch device implementations, pressing the rocker sends an N-message and releasing the rocker sends a U-message!

If ORG = 0x06, 0x07, 0x08 or 0x0A (all other telegrams)

7	0
Reserved	RP_COUNTER

Reserved	(4 bit)	for future use
RP_COUNTER	(4 bit)	Repeater level: 0 original message 1 repeated message

Description of ChkSum

Least Significant Byte from addition of all octets except sync bytes and checksum.
The checksum is calculated automatically by the library.

*char getRadioTelegram(union telegram *telegram)*

When a radio telegram is received the telegram content (11 byte) is stored internally. There is a buffer for several telegrams. The number of buffers is defined via # define `_NR_RX_RADIO_BUFFERS` as described above. The default number of buffers is 4 (maximum value 10). With the function `getRadioTelegram()` the telegram content is made available. Identical telegrams arriving within the maturity time of the buffer (default 100ms) are treated as one telegram (typically EnOcean transmitters are repeating the same message 3 times to improve the transmission probability).



Returns

- 0 telegram received
- 1 telegram filtered.
- 2 not received telegram
- 3 telegram stored in the last free rx radio buffer
- 4 rx radio buffer overflow.
- 11 parameter address not allowed

char sendRadioTelegram(union telegram *telegram)

With this command one radio telegram can be transmitted. In order to achieve a high level of transmission probability it is recommended to send 3 telegrams at random intervals within 40ms. Random intervals can be generated using the pseudo random functions in `stdlib.h` of the C18 compiler.

Returns

- 0 telegram sent
- 1 ID incorrect or data not allowed. Telegram not sent.
- 2 ORG byte not allowed. Telegram not sent
- 3 telegram couldn't be sent within 5ms
- 4 telegram written in last free tx radio buffer
- 11 parameter address not allowed

char setRadioFilter(unsigned long ID)

All received telegrams except modem telegrams will be filtered and all telegrams which do not stem from the module with the specified ID will be discarded.

Please note: Filtering is done only for the `getRadioTelegram()` function. The repeater - if activated - will repeat also telegrams with other IDs.

Returns

- 0 filter set

char setRadioBufferMaturity(unsigned char time)

With this command the maturity time of the rx radio buffers may be changed. The default value is 100ms. Identical telegrams arriving within the maturity time are treated as one telegram. This is necessary because a transmitter usually transmits up to 3 sub-telegrams. In addition a repeater may increase this number. 100ms are set as default value for optimal performance with a repeater. If no repeater is installed or the transmitter transmits less sub-telegrams the maturity time can be reduced. This may be helpful in environments with a large number of transmitters.

The value for *time* must be between 2 and 254 (ms).

Returns:

- 0 Maturity value correctly written.
- 1 Maturity value correctly written. Value under 100ms.
- 2 Error code. Maturity value not written. Input value <2ms or >254ms
- 3 Error code. Maturity value not written. Value under 60ms not allowed when repeater active

char setSerialSpeed(unsigned char SpeedCode)

With this command the serial speed may be set. The default value is 9600 bit/s.

Code	Serial speed (bit/s)
1	9600
2	19200
3	38400
4	57600

Returns:

- 0 Serial speed correctly set
- 1 Error code. Invalid input value.

char clearRadioFilter()

No radio telegram IDs are filtered

Returns

- 0 filter cleared

char setIDBase(unsigned long IDBase)

With this command the user can rewrite its ID range base number. The information of the 25 most significant bits is stored in EEPROM. This command can only be used a maximum number of 10 times to avoid misuse. Please note that this command needs ~20ms for execution. Therefore in _CONFIG 1 and 4 a reset will be performed by the WDT. If one of these configurations is used please switch off the WDT during execution of this command.

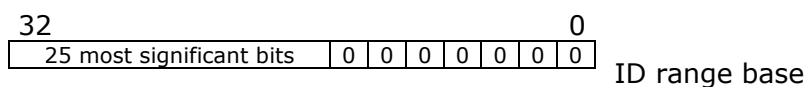

Returns

- 0 new ID base set
- 1 ID base < 0xFF800000. ID base not allowed. New ID not set
- 2 ID programmed more than 10 times. New ID not set

Important note: When the module is programmed with your application the ID originally written to the TCM 120 module at production time is erased. The default value of the ID after programming is "FFFFFF80". Therefore the ID has to be changed after programming. It is recommended to read the ID from the TCM 120 module before programming using the serial interface as described in the TCM 120 user manual and write this ID back to the module after programming (see Sample 2 in Appendix C).

unsigned long readIDBase()

Returns

unsigned long IDBase;

Codes in [0xFF800000, 0xFFFFFFFF] with 7 LSBs to 0

char setRxSensitivity(unsigned char sensitivity)

With this command the TCM radio sensitivity is set.

In LOW radio sensitivity signals from far transmitters are not detected by the TCM receiver. This feature is useful when only information from transmitters in the vicinity should be processed.

sensitivity: 1 = high sensitivity (typ. -95 dBm)
 0 = low sensitivity (typ. -65 dBm)

Returns

0 sensitivity set
1 radio sensitivity μ C pin (RA4) wrongly configured as input. Sensitivity not set

char readRxSensitivity()

Returns

0 low radio sensitivity (typ. -65 dBm)
1 high radio sensitivity (typ. -95 dBm)
2 radio sensitivity μ C pin (RA4) wrongly configured as input. Sensitivity not read

char sleep(unsigned long time)

Sleep for a time interval specified in WDT period units (as defined in _CONFIG). The I/O ports maintain the status they had before the Sleep instruction was executed. For lowest current consumption in this mode, place all I/O pins at either VDD or VSS, ensure no external circuitry is drawing current from the I/O pin. Pull all I/O pins that are hi-impedance inputs, high or low externally, to avoid switching currents caused by floating inputs.

With a signal change on the SER_RX line it is also possible to wake up the module.

Please note:

- If the WDT has been switched off the unit will only wake up with the signal change on SER_RX!
- If a telegram has been sent via the serial interface using the *sendSerialTelegram()* command it is necessary to wait for about 20ms before entering the sleep mode. Otherwise the serial telegram will not be transmitted completely.
- RX/TX radio buffers are erased by the function before entering in sleep.

Returns:

0 Watch dog timer woke up μ C from sleep
1 External signal woke up μ C from sleep

char receiverOn()

The receiver is switched off after the start-up of the module. With this command the receiver is switched on, the power consumption strongly increases.

Global unsigned char rec_pdown; /* TRUE if receiver powered down,
FALSE if receiver is running */

The flag rec_pdown is set according to the current status.

Returns

- 0 radio receiver enabled
- 1 radio receiver control pin (RC0) wrongly configured as input. Action not performed
- 2 radio rx_data pin (RB4) wrongly configured as output. Action not performed
- 3 radio antenna switch 1 pin (RB2) wrongly configured as input. Action not performed
- 4 radio antenna switch 2 pin (RC5) wrongly configured as input. Action not performed

char receiverOff()

With this function the receiver can be switched off. The flag rec_pdown is set according to the current status.

Global unsigned char rec_pdown; /* TRUE if receiver powered down,
FALSE if receiver is running */

Returns

- 0 radio receiver disabled
- 1 radio receiver control pin (RC0) wrongly configured as input. Action not performed

char repeaterOn()

Switches the integrated repeater function on. For a set of sub-telegrams belonging to the same telegram the repeater functions generates typically three repeated sub-telegrams. If the air channel is occupied at the moment of sending the number of repeated sub-telegrams may be smaller than 3. Telegrams which have already been repeated are not repeated again. Remote learn telegrams are not repeated!

Please note: The *receiverOn()* command is executed automatically. The *getRadioTelegram()* routine must be called on a regular basis! The RX buffers are only released if the maturity time has elapsed and the buffer content has been read via *getRadioTelegram()*. Otherwise the repeater will stop working!

Returns

- 0 radio repeater enabled
- 1 radio repeater could not be enabled. Maturity time < 60ms radio repeater could not be enabled.
- 2 Number of TX radio buffers < (Number of RX radio buffers+1)
- 3 radio receiver control pin (RC0) wrongly configured as input. Action not performed
- 4 radio rx_data pin (RB4) wrongly configured as output. Action not performed
- 5 radio antenna switch 1 pin (RB2) wrongly configured as input. Action not performed
- 6 radio antenna switch 2 pin (RC5) wrongly configured as input. Action not performed

char repeaterOff()

Switches the integrated repeater function off. The radio reception remains active. The RX and TX buffers will be cleared.

Returns

0 radio repeater disabled

void reset()

Performs a reset of the module.

char writeOut(unsigned char outPin, unsigned char level)

Set OUT_0 to OUT_4 level as defined in level. The current status is stored in the global structure output.

```
char outPin; /* 0 to 4 for OUT_0 to OUT_4 */
char level; /* TRUE=HIGH level, FALSE=LOW level */
```

```
global struct out{
unsigned OUT0      :1; /* TRUE=HIGH level, FALSE=LOW level */
unsigned OUT1      :1;
unsigned OUT2      :1;
unsigned OUT3      :1;
unsigned OUT4      :1;
unsigned reserved  :3;
}output;
```

Returns

0 state written to pin
1 some output pin is configured as input
2 pin value not allowed
3 OUT_4/SER_TX configured as SER_TX

char configInputs(unsigned char configCode)

This function configures the TCM130 input pins as analog, digital or reference input. The table summarizes the available codes and configurations. The default configuration is 0x00. If the SER_RX is configured as IN_4 (configSerialPins) it is always a digital input.

Code	IN_3	IN_2	IN_1	IN_0	Vref+	Vref-
0x00	A	A	A	A	Vdd	Vss
0x01	A	Vref+	A	A	IN_2	Vss
0x04	D	A	D	A	Vdd	Vss
0x05	D	Vref+	D	A	IN_2	Vss
0x08	A	Vref+	Vref-	A	IN_2	IN_1
0x0D	D	Vref+	Vref-	A	IN_2	IN_1
0x0E	D	D	D	D	Vdd	Vss

A: analog input

D: digital input

Vref+/Vref-: reference input

Returns

0 configuration entered

1 configuration code not allowed. Configuration not entered.

char configSerialPins(unsigned char pinConfigCode)

This function is used to configure the TCM130 pin 7 and 8 as serial pins or as digital input/output. At startup pin7/8 are configured as serial pins.

PinConfigCode =0 : Pin7= IN_4 ; Pin8= OUT_4;

pinConfigCode!=0 : Pin7= SER_RX ; Pin8= SER_TX

Returns

0 configuration performed.

1 pin7 IN_4/SER_RX configured wrongly as output

2 pin8 OUT_4/SER_TX configured wrongly as input

char readADIn(unsigned char inPin, unsigned char resolution, unsigned int *ADconversion)

Performs a measurement of the voltage at this input (inPin=0..3 for IN_0..3) using the built-in A/D converter with a resolution defined by the parameter resolution (in bit; max. 10 bit) and stores the result in *ADconversion.

Returns

0 A/D process performed

1 analog IN_0 not configured as analogue. A/D not performed

2 analog IN_1 not configured as analogue. A/D not performed

3 analog IN_2 not configured as analogue. A/D not performed

4 analog IN_3 not configured as analogue. A/D not performed

5 inPin value not allowed. A/D not performed

6 analog IN_0 configured as output. A/D not performed

- 7 analog IN_1 configured as output. A/D not performed
- 8 analog IN_2 configured as output. A/D not performed
- 9 analog IN_3 configured as output. A/D not performed
- 10 resolution value >10. A/D not performed
- 11 address pointed to by 3rd parameter not allowed. A/D not performed

char readDigitalIn(unsigned char inPin, unsigned char *level)

Reads the level of the input pin inPin (inPin =0 for IN_0 .. 4 for IN_4) and stores the result in *level (TRUE if HIGH level, FALSE if LOW level).

Returns

- 0 read process correct
- 1 IN_0 not configured as digital. Reading not performed
- 2 IN_1 not configured as digital. Reading not performed
- 3 IN_2 not configured as digital. Reading not performed
- 4 IN_3 not configured as digital. Reading not performed
- 5 inPin value not allowed. Reading not performed
- 6 IN_0 configured as output. Reading not performed
- 7 IN_1 configured as output. Reading not performed
- 8 IN_2 configured as output. Reading not performed
- 9 IN_3 configured as output. Reading not performed
- 10 IN_4/SER_RX configured wrongly as SER_RX. Reading not performed
- 11 address pointed to by 2nd parameter not allowed . Reading not performed
- 12 IN_4/SER_RX configured as output. Reading not performed

unsigned long getTime()

This command returns a time stamp from the internal system clock. The time stamp is increased every ms (->restart from 0 after about 50 days). During sleep the timer is stopped.

Please note: During the transmission (also repeating!) and reception of radio telegrams the timer may be delayed by about 1 ms per telegram.

Returns

Current 32 bit time stamp [0x0-0xFFFFFFFF] in milliseconds

void nop()

Performs a non-instruction cycle. Each nop instruction lasts 100ns.

void wait(unsigned long delay)

Performs a delay of *delay* milliseconds. A clear watch dog timer is implemented to avoid a possible reset.

void clrWdt()

Clears the watch dog timer counter. Clear watch dog timer should be used preferably only once in the program. It should be written in a source code point which is executed on a regular basis. Not clearing WDT though this instruction within a WDT period provokes a reset of the TCM130 µC. Only in sleep modus the program can stay longer than the WDT period.



void switchWdtOn()

Switches the WDT on. By default the WDT is on (`_CONFIG 6`).

void switchWdtOff()

Switches the WDT off. This allows saving around 10µA current consumption. If the WDT is off before going to sleep waking-up is only possible through a hardware signal change on pin 7 (`SER_RX`).

char writeEeprom(unsigned char eepromAddress, unsigned char data)

Writes the byte in "data" in the EEPROM address. EEPROM address codes allowed are in the range [0x50, 0xDF]. Other values out of this range are already used by the library and are therefore not permitted. It is recommended to read the value in EEPROM after a write command for verification purposes.

Returns

0 code correctly written in EEPROM
1 address in 1st parameter not allowed

char readEeprom(unsigned char eepromAddress, unsigned char *data)

Reads data from EEPROM address `eepromAddress` and returns the value in `*data`.

Returns

0 code correctly read from EEPROM
1 not allowed address code in 1st parameter
11 not allowed address in second parameter

Allocation of variables in RAM

In total about 0.5kB of RAM are available. They are distributed over 2 memory areas. For a single source code file the compiler is only able to allocate variables in one of these areas unless the user specifies by using pragmas (outside a function) where the variables have to be allocated. The largest connected memory area of 336 bytes is "ApplicBank". Please use this area for large arrays, strings, unions or structures. If not more than 336 bytes of RAM in total are needed for the application the allocation works automatically.

Example for more allocating more than 336 bytes:

```
#pragma udata ApplicBank
unsigned char var1[336];
#pragma udata
```

```
void main(){
unsigned char var2[10];
...
}
```

In this case `var1` is located in the special area defined as "ApplicBank", `var2` is put into the other memory section.

For more information please refer to *MPLAB® C18 C Compiler User's Guide*.

A. Development Tools

A.1 Microchip Tools

Microchip offers a tool suite for the PIC 18F452 micro controller. EnOcean recommends to use the following tools:

- Microchip MPLAB® ICD 2 in-circuit debugger
- Microchip MPLAB® IDE, version 7.3
Please find version 7.3 on the CD-ROM. The license terms and conditions of Microchip apply! The IDE is also available for free download from www.microchip.com
- Microchip MPLAB® C18 C-Compiler, version 3.0. Please find the full featured 60 day Student Edition on the CD-ROM. The license terms and conditions of Microchip apply! The 60-day student edition is also available for free download from www.microchip.com.

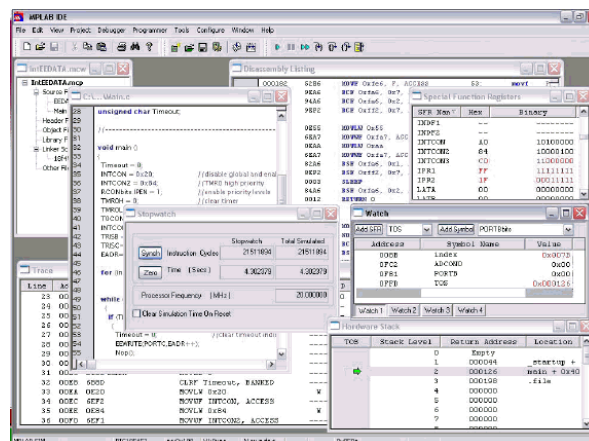
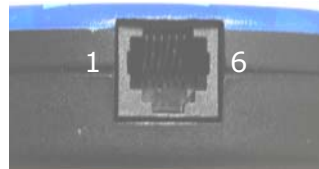

Figure 10: Microchip ICD 2 and MPLAB®

Pin-out of the ICD 2 connector:

Color	Description
1	Not used
2	Programming Clock
3	Programming Data
4	GND
5	Vdd
6	MCLR/Vpp



A.2 EnOcean Tools

EnOcean offers a TCM 130 Starter Kit containing an evaluation board, an adapter for the MPLAB® ICD2 device from Microchip and 2 modified TCM 120 modules³ with mounted expansion port connector. The evaluation board originally has been developed for use with RCM110/120 and TCM120. It is also possible to use it for the development of TCM 130 applications.

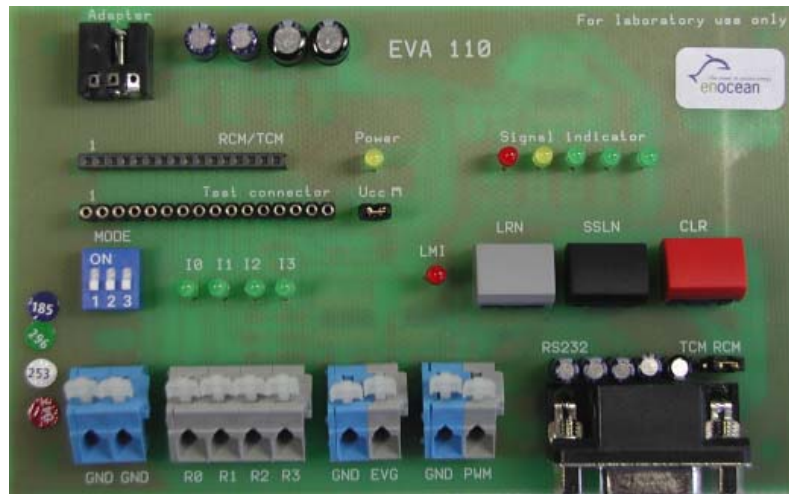

Figure 11: EnOcean EVA 110 board

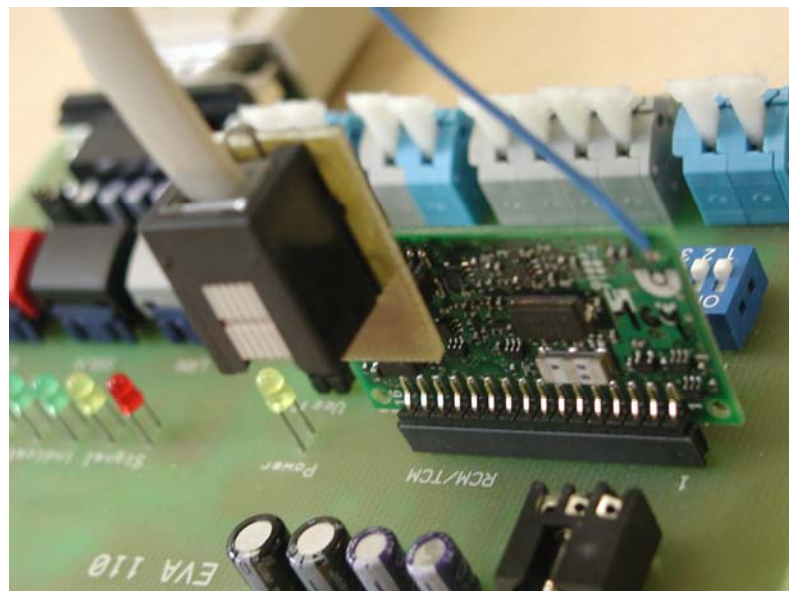

Figure 12: Adapter for MPLAB® ICD 2

³ **Important note:** The expansion port connector, which is mounted for development purposes on the modules supplied with the TCM 130 Starter Kit is not mounted on standard TCM 120 modules. In order to program the TCM 120 modules with own software it is necessary to contact the programming pins with needles.

The meaning of connectors, indicators and switches are however different from the description in the EVA 100 manual.

Description of On-board Connectors

Symbol	Function	Operational characteristics
Adapter	Female jack for power supply	14 - 30 V, 100 mA max.
RCM/TCM	Female header for plug-in RCM or TCM module (Pin 1 is module antenna side)	
Test Connector	Female header connected directly to module leads. Input IN_0 .. IN_3 are available here.	
Vcc	Jack to disconnect the power supply to the inserted module	Bridge
GND GND	Ground connectors for functional control outputs	
R0	No function	
R1 R2 R3	Functional control outputs directly connected to the OUT_0..2 output pins of inserted module	5V CMOS output, 20 mA max.
GND EVG	No function	
GND PWM	No function	
RS232	DB9 female serial interface connector to PC <ul style="list-style-type: none"> RCM 120, Operating Mode 0 (Rx) TCM 120 (Rx and Tx) 	12 V
TCM RCM	Selector for RCM or TCM module operation	Bridge

Description of On-board Switches

Symbol	Function
MODE	Switch 1 can be used to reset the module Switch 2 connected to IN_0. External pull-up needed! Switch 3 connected to IN_1. External pull-up needed!
LRN	Connected to IN_2. External pull-up needed!
SSLM	Connected to IN_3. External pull-up needed!
CLR	Connected to IN_4. External pull-up needed!



Figure 13: External pull-ups

Description of On-board Indicators

Symbol	Function
Power	Power supply indicator
Signal indicator	Indication output of received signal strength of all 868.3 MHz signals (peak detection) <ul style="list-style-type: none"> • Red: No Radio Signal • Yellow: Weak Radio Signal • Green 0..2: Strong Radio Signal
I0	Indicator for activity on SER_TX; Status indicator for OUT_4 (inverted status)
I1	Status indicator for OUT_0 .. OUT_2
I2	Please note that the inverted status is shown
I3	("1" = LED off)
LMI	Status indicator for OUT_3 ("1" = LED on)

B. Installation

- Install the MPLAB® environment (IDE, C-Compiler and ICD 2)
- Unpack the TCM130_Vxxxx.zip in one folder
- Copy clib.lib, p18f452.lib and p18f452.h from the installation directory of your MPLAB® C18 C-compiler to this folder

After that you can start MPLAB® and open the project MyTCM130Project.mcp.

If everything is installed correctly you should now be able to compile the project using the "Build All" button.

C. Sample Applications

Sample 1

During the first 20s after startup this sample application learns the ID of a PTM 100 switch and stores it in EEPROM. Afterwards a filter for this ID is set. Every time a telegram from this switch is received OUT_2 is set if a key is pressed and cleared if the key is released.

```

//Watch dog timer period and brown-out detection configuration
//WDT period ~2s, BOD on
#define _CONFIG 3

#include "p18f452.h"
#include "TCM130_LIB.h"
#include "TCM130_CFG.h"

void main(void){
    unsigned long ID;
    union telegram t1;
    unsigned char result,id0,id1,id2,id3;
    unsigned long time1;

    initTCM130(); // TCM130 init function. This function must always be here as first program line. It
                // initializes the TCM130.
    receiverOn(); // by default receiver is off. Radio receiver functionality is desired radio receive must
                // be activated.
    setRxSensitivity(0); // Low sensitivity for learn mode
    writeOut(3,1); // LRN mode indicator
    time1=getTime();
    do{
        clrWdt();
        //when a PTM radio telegram is received, the information will passed to t1 union.
        if(!getRadioTelegram(&t1) &&t1.org==5){
            writeEeprom(0x50,t1.id0); //store ID in EEPROM
            writeEeprom(0x51,t1.id1);
            writeEeprom(0x52,t1.id2);
            writeEeprom(0x53,t1.id3);
            break; //exit LRN mode
        }
    }while((getTime()-time1)<20000); //end learn mode after 20s
    setRxSensitivity(1);
    writeOut(3,0); // LRN mode indicator off

    clrWdt();
    readEeprom(0x50,&id0); //read ID from EEPROM
    readEeprom(0x51,&id1);
    readEeprom(0x52,&id2);
    readEeprom(0x53,&id3);
    ID=(unsigned long)id0+(unsigned long)id1*0x100+(unsigned long)id2*0x10000+(unsigned long)id3*0x1000000;
    clrWdt();
    setRadioFilter(ID); // set filter for learned ID

    while(1){
        clrWdt();
        //when a radio telegram is received, the information will passed to t1 union.
        if(!getRadioTelegram(&t1)){
            //the serial telegram is sent through serial port
            t1.type=0x0B; //this code is part of EnOcean serial protocol.
            sendSerialTelegram(&t1); //radio bytes received are send through the serial port
            if (t1.data3&0x10) writeOut(2,1); //switch output 2 on if key pressed
            else writeOut(2,0); //switch ouput 2 off if key released
        }
    }
}

```

Sample 2

At startup this application checks if already an ID has been programmed (ID different from FFFFFFF80). If the ID has not yet been programmed the application waits for a SET_IDBASE telegram (TCM 120 User Manual) to change the ID.

If the ID has already been set it is provided via a serial telegram. You can monitor it using the TCM-Monitor application provided on CD-ROM.

```
//Watch dog timer period and brown-out detection configuration
#define _CONFIG 3 //WDT period ~2s, BOD on

#include "p18f452.h"
#include "TCM130_LIB.h"
#include "TCM130_CFG.h"

void wait(unsigned long delay);
void checkID(void);

void main(void){
    unsigned long ID;
    union telegram t1;
    unsigned char result;

    initTCM130(); //TCM 130 init function

    checkID(); // Check if ID already programmed. If not wait for serial SET_IDBASE telegram
               // with ID as defined in TCM 120 documentation

    t1.type=0x0B; //this code is part of EnOcean serial protocol.
    t1.org=0x07; //4BS-Telegram
    ID=readIDBase();
    t1.id0=ID&255; //convert ID into ID bytes 0..3
    t1.id1=(ID/256)&255;
    t1.id2=(ID/256/256)&255;
    t1.id3=(ID/256/256/256)&255;
    sendSerialTelegram(&t1); // send serial telegram with ID
    wait(20); // 20ms delay to make sure telegram is sent before module goes into reset
}

void wait(unsigned long delay) //delay in ms
{
    unsigned long tstart;
    tstart=getTime();
    do{clrWdt();}while((getTime()-tstart)<delay);
}

void checkID(void){
    unsigned long ID,csum;
    unsigned char tel[14],i;

    ID=readIDBase();
    if (ID==0xFFFFFFFF) { //ID not yet programmed
        do{
            clrWdt();
            getSerialByte(&tel[0]);
        }while(tel[0]!=0xA5); // wait for sync byte
        for (i=1;i<14;i++){ // read serial telegram with 14 bytes
            clrWdt();
            do{clrWdt();}
            while(getSerialByte(&tel[i]));
        }
        csum=0;
        for(i=2;i<13;i++){
            csum+=tel[i];
        }
        if ((csum&255)!=tel[13]) reset(); //Perform Reset if Checksum not OK
        if ((tel[0]==0xA5)&&(tel[1]==0x5a)&&(tel[2]==0xAB)&&(tel[3]==0x18)){ // SET_IDBASE command?
            ID=(unsigned long)tel[7]+(unsigned long)tel[6]*0x100+(unsigned long)tel[5]*0x10000+(unsigned
            long)tel[4]*0x1000000;
            setIDBase(ID);
        }
    }
    reset();
}
}
```