

 **vega**
gps bracelet



everon™
www.everon.net



Table of Contents to become fully acquainted with the VEGA gps bracelet

About the User Manual	3	D) In case of an emergency:	
A) System Components	4	press the red button	13
Vega	4	E) Automatic Low battery alert	14
Vega Base	4	F) Locating Vega	14
Battery pack	5	G) Environmental Conditions	
Bracelet parts	5	and Restrictions	14
Release key	5	1. General instructions	14
B) Getting started: Vega System		2. Water	15
Installation and Charging	6	3. Special restrictions	15
Step 1: Bracelet selection and fitting	6	4. Customer Service	15
Step 2: Vega Base location and installation	7	5. Recycling Vega and Components	15
Step 3: Charging the battery pack	8	H) Specifications	16
Step 4: Charging Vega	10	1. Technical specifications	16
C) Vega Operating Modes	11	2. Battery autonomy	16
1. Inside the home zone (Sleep mode)	11	3. Network services	16
2. Outside the home zone		4. Specific Absorption Rate	16
(Regular mode AND INSIDE SAFE ZONE)	12	I) Legal Advice	17
3. Exiting the safe zone	12	1. Intellectual property	17
4. Vocal communication	13	2. Statement of compliance	18

About the User Manual

This Guide is published by Everon, who may at any time make changes, improvements or typographical corrections without prior notice.

At the time that this Guide went to press, the information it contains was deemed, by Everon oy , to be true and accurate.

The trademarks "Vega" and "Everon" are the property of Everon Oy.

Other products and/or company names cited in this Guide may be trademarks of their respective holders.

Publication number: EUC2-200908-A-EN
 Copyright ©2009

A) System Components

Vega

- A. Display
- B. Emergency button
- C. Display button
- D. Speaker/microphone
- E. Latches to hold battery pack in place on Vega during charging

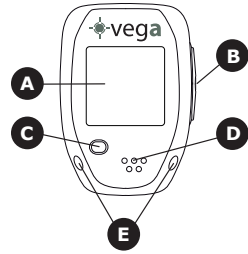

Vega Base

- A. Latches to hold battery pack in place on the Vega Base during charging
- B. Receptacle for latch release key
- C. Radiofrequencies (RF) antenna
- D. Battery pack base
- E. Electrical contacts for recharging battery pack (back)
- F. Blue LED – Vega Base working when ON
- G. Red and green LEDs – Battery pack charging when Red, and goes Green when fully charged
- H. Holes for optional wall mounting
- I. Telephone jack
- J. DC power jack

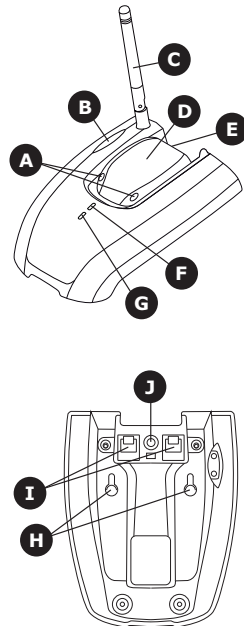

Battery pack

- A. Latch – Push in, to hold battery pack either on the Vega Base or on the Vega
- B. Holes for inserting key to release battery pack from latches on the Vega Base or on the Vega
- C. Blue LED – Vega charging when ON, and goes OFF when battery pack charge is transferred to Vega battery
- D. DC power jack for recharging

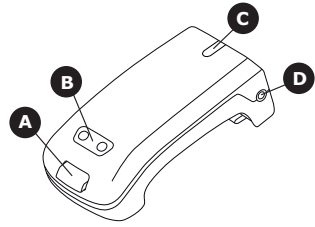

Bracelet parts

- A. Wrist straps with holes (2 sizes)
- B. Steel pin
- C. Wrist straps with safety snaps
- D. Clasp with two screws
- E. Vega bracelet support

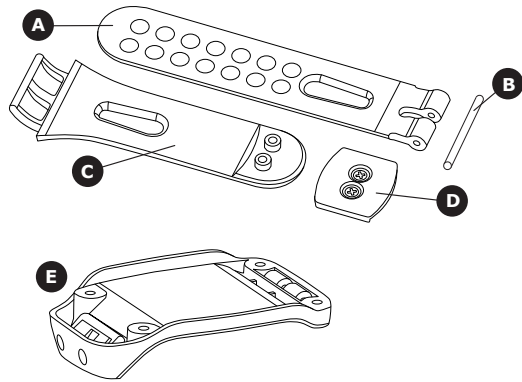

Release key

- A. Two-pin key to release mechanism

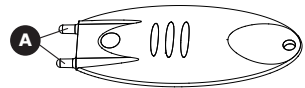

B) Getting started: Vega System Installation and Charging

Step 1: Bracelet selection and fitting

Vega comes with two wrist straps of different sizes to ensure a proper fit on a wide range of wrist sizes. In addition, the length of each wrist strap can be adjusted for greater wearer comfort and maximum safety.

Bracelet parts are shipped semi-assembled and must be disassembled to adjust the parts before the bracelet can be fitted.

1. Insert the wrist strap with safety snaps into the slot on the Vega support.
2. Insert one of the two wrist straps with holes, depending on the size of the wearer's wrist, with the grooved side facing the skin.
3. To select the wrist strap providing a better fit, wrap each of the straps provided around the wearer's wrist. Select the strap with the end holes that line up with the end holes on the other strap.

Choose the holes that allow the best possible fit so the wearer cannot remove the bracelet without unlocking it, while being loose enough to be comfortable and not impede blood circulation.
TO AVOID INJURY, DO NOT OVERTIGHTEN THE BRACELET.

4. Once you have selected the right size wrist strap, slip the steel pin through the strap to lock it onto the Vega support, as illustrated.
5. Remove the strap with safety snaps by inserting the key into the mating holes on the Vega support.
6. Gently push the strap with safety snaps.

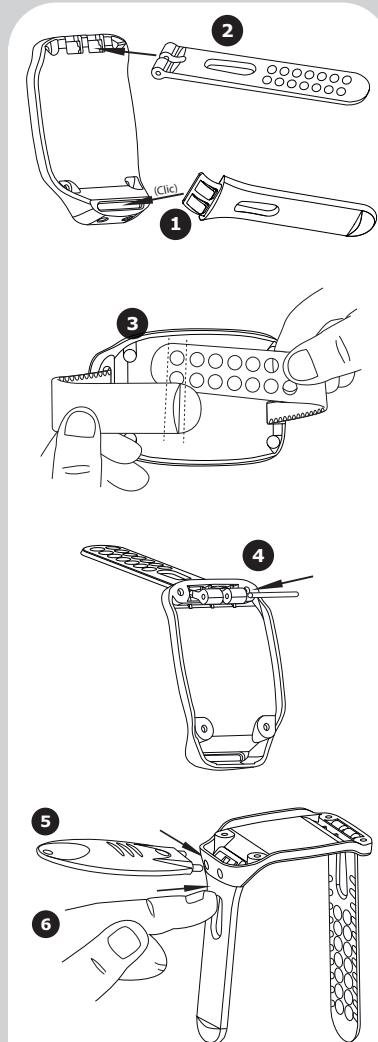

7. Assemble the Vega on its support using the four screws to attach it onto the back of the support.
8. Slip the end of the bracelet with safety snaps into the lock and line it up with the holes previously found to ensure a proper fit. Then screw the lock onto the strap with holes using the screwdriver provided in the Vega package.
9. Next, place the bracelet with the Vega assembled around the wearer's wrist, slipping the strap with safety snaps into the slot of the Vega support.

If you need to take the Vega off the wearer's wrist, follow steps 5 and 6 above.

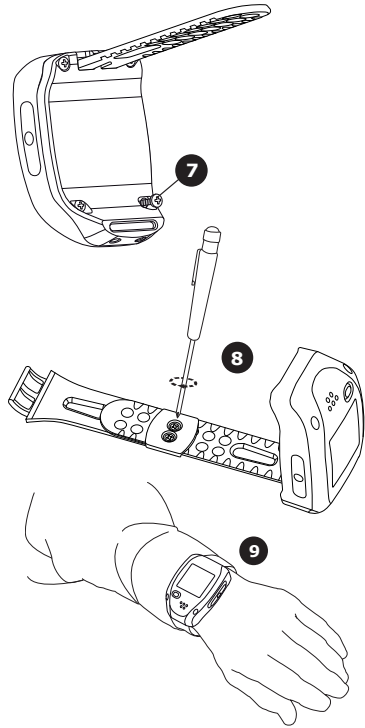

Step 2: Vega Base location and installation

Power Supply

First, connect the power adapter into the DC-in jack located underneath the Vega base. Then, connect the power adapter into the home power outlet. The blue LED turns on. It indicates that the Vega base is functional.

Positioning the base in the home

The Vega Base has a radiofrequency (RF) transmitter that creates an area, called the home zone, in which the Vega goes into economy mode (details found further in the Guide).

It is very important that the Vega Base be properly located in the wearer's home. It is best placed near the middle of the home so that the home zone covers the largest possible indoor area, or in the area where the wearer is most often found, including at night. If the Vega Base is in a poor location, Vega will consume more power since it is more often outside the home zone and cannot benefit from the lower power battery consumption in economy mode.

Vega displays the home icon when inside the RF zone.



Everon recommends that you use the display on the Vega to test the covered area by the Vega Base and determine the most efficient location. Simply press the display button when in a specific place indoor, and look for the home icon presence on the screen. The detection of the RF signal requires a synchronization time of one (1) minute.

The Vega Base may be set down horizontally on a flat surface or mounted vertically using the holes in the back of the Vega Base. It is recommended to put the Vega Base in a location that is not easily reachable by the Vega wearer.

Step 3: Charging the battery pack

(1) Place the battery pack on the base station by first inserting the hooked-end side into the cavity provided on the base station, (2) and then flipping it down to rest on the base. (3) Next, press the latch mechanism forward on the end of the battery pack. This mechanism secures the battery pack to the latches on the Vega Base.

When the latch mechanism is pushed forward correctly, the Vega Base's red LED and the battery pack's blue LED turn on to show that charging is in progress. The red LED turns green and the blue light turns off when the pack is fully recharged. Charging the battery pack takes on average two and a half hours.

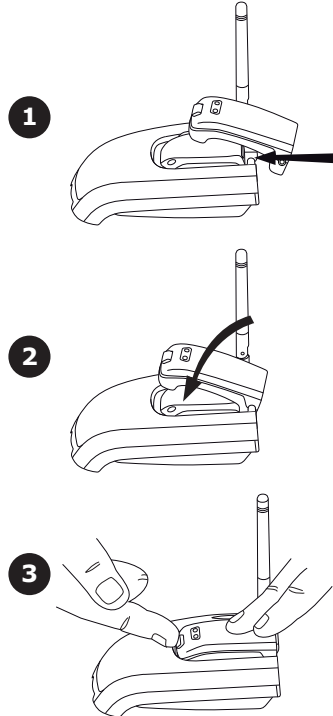

To remove the battery pack from the Vega base, release the latch by inserting the key into the two holes as shown. You will hear a click when the mechanism has been released. Always put the key back on the base, inside its receptacle, after using it so that it doesn't get lost.

**DO NOT FORCE THE MECANISM,
IT MAY CAUSE DAMAGE**

Both the battery pack and the Vega battery will gradually lose their charge if they are not used for a long period of time.

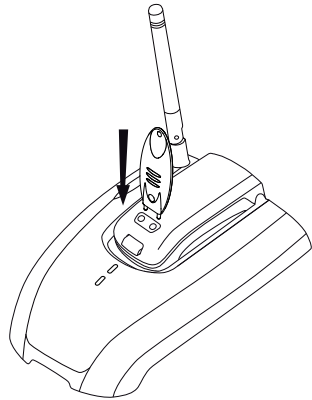

The charging system is designed so that the battery pack is always resting either on the Vega Base or on the Vega. During a power failure, the battery pack can supply backup power to the Vega Base. For this to happen, place the battery pack in its normal position on the Vega Base and the Vega Base's blue LED will turn on. When the battery pack charge is too low, the red LED will start to flash.

The battery pack may be charged using the AC/DC power supply provided in the package and connecting it directly to the DC power jack of the battery pack.

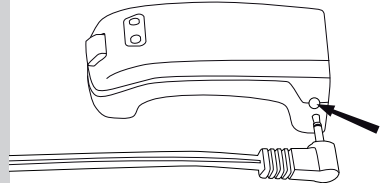

Step 4: Charging Vega

Vega's built-in battery can only be recharged using the battery pack. Before charging the Vega, the battery pack itself must be fully charged.

To attach the battery pack onto the Vega, first insert the hooked-end side into the cavity provided on the Vega, and then flip it down to rest on the Vega. Next, press the latch mechanism forward onto the end of the battery pack. This mechanism secures the battery pack to the latches on Vega.

If the mechanism is inserted correctly, the battery pack's blue LED turns on to show that Vega is charging. The battery pack's LED turns off when it is discharged. Charging the VEGA gps bracelet can take up to three hours.

It should be noted that both the Vega base and the battery pack can be charged using the AC/DC adapters provided with the VEGA gps bracelet at the time of delivery or subscription.

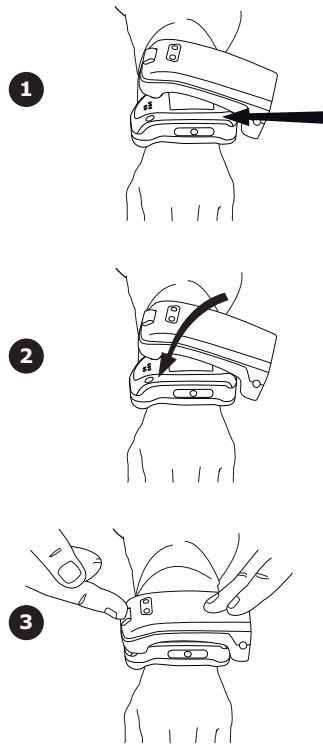

When you charge the Vega for the first time or when the battery charge level is very low, it is best to perform the charging process twice for an optimal charge or to connect the battery pack to the power outlet while secured on Vega.

At all times, the battery icon displayed on the Vega indicates the battery charge level.

A red empty battery icon sends a warning that Vega's battery charge level is low. Automatically, Vega generates an optional email alert.

To remove the battery pack from the Vega, release the latch by inserting the key into the two holes on the battery pack. You will hear a click when the mechanism has been released. Always put the key and the battery pack back on the base after using it so that it doesn't get lost.

DO NOT FORCE THE MECANISM, IT MAY CAUSE DAMAGE.

C) Vega Operating Modes

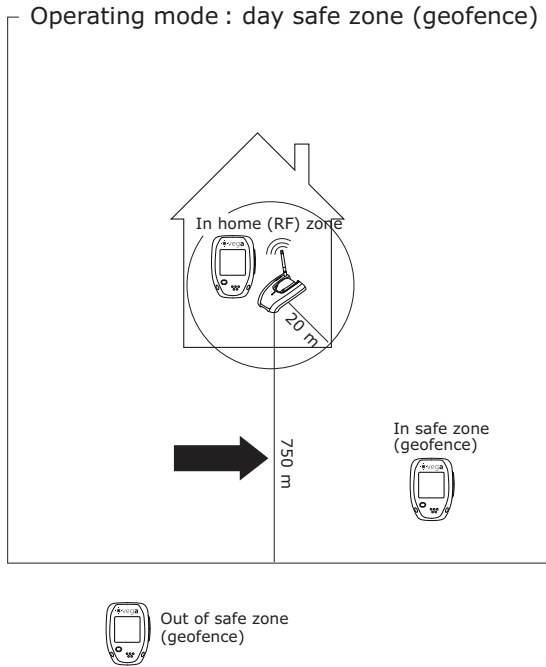

1. Inside the home zone (Sleep mode)

The Vega Base emits radiofrequency (RF) waves similar to those of a home cordless telephone. The waves have a maximum range of 50 m but that range will vary depending on the Vega Base's surroundings (e.g., thickness of the walls and what they are made of).

When Vega is inside the home (RF) zone, some of its features (including its GPS) go into sleep mode, because the Vega communicates with its base by using very little battery power. It places itself in an economy state: the sleep mode.

Vega displays the home icon when inside the home zone.



The emergency button still works and can be used in the event of a malaise or other serious problems.

Warning! If you move your Vega Base with the battery pack clipped on it (e.g., during a trip), the Vega Base will continue to emit RF signals giving the false impression that Vega is still in its usual home zone and safe zone. Therefore, the application will read that the wearer is within its home zone. However, should the battery charge reach a low level point, the watch will transmit its position to the response center.

2. Outside the home zone (Regular mode AND INSIDE SAFE ZONE)

When Vega is outside the home zone, all Vega features are in function and the home icon is no longer displayed. Vega regularly searches for and records in memory its geographic location using its assisted GPS (A GPS) module. It regularly compares its location to the preloaded map of the safety zone. The icons on the Vega display show the operations it is performing.

The magnifying glass indicates that the GPS is working, and trying to determine its position.



The push-pin indicates that the A-GPS was able to determine its position with accuracy.



The emergency button works at all times, regardless of the wearer's location and can be used in the event of a malaise or other serious problems.

Warning!

Keep in mind that this feature only works in areas covered by the GPS and GSM/GPRS systems.



■■■■ This icon indicates that no GSM/GPRS signals are available; therefore the Vega will not be able to transmit information to the response center such as its position, and no alert can be sent.

■ ■ ■ ■ The Vega MUST indicate at least a "one-bar icon" to transmit information.

GEOLOCALISATION

Vega regularly searches for and records in memory its geographic location using its assisted GPS (A GPS) module when outside of its home (RF) zone. When Vega is in its home zone, the address associated with the home zone is transmitted to the response center.

3. Exiting the safe zone

When Vega detects that it is outside the safe zone (geofence), it automatically generates an out-of-safe-zone alert to notify the response centre of this situation. The alert is handled by the response centre following the procedure set down with the subscriber (e.g., the wearer's emergency contacts are notified so that they can take action to correct the situation).

Note: During an alert, it is possible that the operator at the response centre or a family member talk to the wearer.

The emergency button works at all times, regardless of the wearer's location and can be used in the event of a malaise or other serious problems.

Keep in mind that this feature only works in areas covered by the GPS and GSM/GPRS systems.

4. Vocal communication

OPERATION

Vega has a built-in hands-free telephone. Vega was not designed for the wearer to dial a phone number and initiate a call. Vega can only receive calls from the response centre or emergency contacts.

For incoming calls, communication is automatically established between the caller and wearer: the latter has nothing to do to accept the call.

To optimize sound quality, the wearer should put Vega in front of his or her face and speak in a normal voice.

To end a call, press the display button for 2 seconds.

CONTACTING THE VEGA WEARER

In an emergency situation or when help is needed, authorized emergency contacts may talk to the Vega wearer by calling the response centre using the hands-free telephone feature.

D) In case of an emergency: press the red button

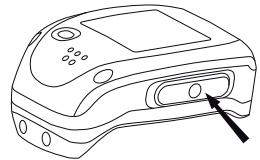

The emergency button must be pushed down for at least two seconds to work. This is done to avoid false alarms by inadvertently pressing on the button.

The Vega displays an exclamation mark that shows that the alert has been sent. The emergency button must only be used in emergency situations, in the event of a malaise or other serious problems.



Vega then transmits its position and an alert to the response centre. The alert is handled by the centre following the procedure set down with the subscriber (e.g., the centre may try to establish vocal contact with the Vega™ wearer in order to assess the situation, or it may call the emergency contacts, inform them of the situation and request that they take action).

Please, keep in mind that the wearer should not move since his or her geographic location was sent immediately to the response centre so help can be quickly dispatched if the procedure so specifies.

Obviously, this feature only works in areas covered by the GPS and GSM/GPRS systems (minimum of one bar shown on the display screen).

Note: it is possible to disable the alert button by contacting the customer service.

E) Automatic Low battery alert

Vega automatically transmits an alert when its battery level reaches a low level or has been recharging for more than 24 hours. The low battery level alert is transmitted only once a day.

The alert is handled following the procedure set down with the subscriber (e.g., an e mail is sent to emergency contacts).

F) Locating Vega

Authorized emergency contacts may request that Vega be located by calling the response centre and by identifying themselves.

The location provided will be the latest position transmitted by Vega.

G) Environmental Conditions and Restrictions

1. *General instructions*

Follow applicable rules in all locations. Vega must not be used where portable telephones are prohibited or where it could create interference or a hazard (e.g., in places where chemicals or inflammable substances are found or stored and in vehicles using petrol or inflammable liquid gas).

Do not use Vega in dusty or dirty places. It may cause damage to certain components.

Only use approved Vega accessories after having read the user's manual. Otherwise, you could permanently damage your system. Also avoid short-circuits, which may damage the batteries or electronic components.

Though designed to be rugged, your Vega system does contain delicate electronic circuitry. Avoid dropping or shaking it.

Your Vega and its battery pack contain lithium polymer batteries and should be kept near room temperature. They should never be exposed to temperatures below -20°C (-4°F) or above $+50^{\circ}\text{C}$ (140°F). Store your system in a dry place at room temperature so its sensitive electronic components are not damaged.

Do not try to open your Vega system to avoid potentially serious injuries or burns, or damage to the system.

Do not paint or put stickers on your Vega system, since this could prevent it from working properly.

2. Water

While Vega is designed to be water-resistant, the battery pack and Vega Base are not. Keep them in a dry location. Rain, humidity and liquids of any sort may lead to corrosion of the circuitry.

3. Special restrictions

PACEMAKERS

Based on independent research and recommendations by Wireless Technology Research, we recommend that people wearing a pacemaker i) always keep Vega more than 20 cm away from their pacemaker; ii) wear Vega on their right wrist; and iii) remove the bracelet immediately if they think interference may occur.

HEARING AIDS

Vega may interfere with some hearing aids, so please consult the manufacturer.

MEDICAL APPARATUS

Any device emitting radio waves, be it a cell phone or your Vega, may interfere with the functioning of insufficiently protected medical apparatus. If in doubt, consult a physician or the medical apparatus manufacturer. Do not use Vega in hospitals or health-care centres where it goes against regulations.

AIRCRAFT

It is prohibited to use Vega during flights. You should plan on discharging your Vega prior to flight time. Using Vega aboard an aircraft could prevent onboard apparatus from working properly.

MAGNETISM

Vega contains some magnetic components. Do not place credit cards or other magnetic recording media near Vega, since the information they contain may be erased.

4. Customer Service

Everon provides information online at www.everon.net.

You may also contact your Customer Service. The phone number can either be found on the website, or in your Vega kit along with the documents it contains.

5. Recycling Vega and Components



To recycle your Vega, or its components, please refer to the regulations in effect in your area.

H) Specifications

1. *Technical specifications*

GSM/GPRS	850/900/1800/1900 MHz
RF	868 MHz (Europe) or 921.4 MHz (North America) 10dBm(max output)
GPS	-159 dBm (Maximum sensitivity)
Electrical supply	220 V 50 Hz 350 mA (Europe) or 120V 60 Hz 350 mA (North America)

2. *Battery autonomy*

Though Vega runs in energy-saving mode inside the home (RF) zone, we recommend that you recharge it daily.

3. *Network services*

Vega is certified for use on GSM/GPRS networks using the 850*/900/1800/1900 MHz bands. It is designed to be used only in those bands. Vega service depends on network coverage at the frequencies above. It is important to check coverage in your area before activating Vega.

Like any mobile telephone, Vega uses radio signals from mobile or wire line networks that may not always guarantee the connection under all conditions. It is thus important that you do not depend entirely upon Vega for your essential emergency and assistance communications.

Everon cannot be held liable for interruptions to GSM/GPRS network services.

4. Specific Absorption Rate

Your Vega is a radio transmitter and receiver. It is designed and manufactured not to exceed limits for exposure to radio frequency (RF) energy. These limits are part of comprehensive guidelines and establish permitted levels of RF energy for the general population. The guidelines are based on standards that were developed by independent scientific organizations through periodic and thorough evaluation of scientific studies. The guidelines include a substantial safety margin designed to ensure the safety of all persons, regardless of age and health.

The exposure standard for mobile phones employs a unit of measurement known as the Specific Absorption Rate, or SAR. The SAR limit set is 2 W/Kg* in European Union and 1.6W/Kg** in North America. Tests for SAR are conducted using standard operating positions with the phone transmitting at its highest certified power level in all tested frequency bands. Although the SAR is determined at the highest certified power level, the actual SAR of the phone, while operating, can be well below the maximum value. This because the phone is designed to operate at multiple power levels, therefore using only the power required to reach the network. In general, the closer you are to a base station, the lower the power output of the phone. The highest SAR value for this model phone is lower than the limit in the 850/900/1800/1900 MHz bands. While there may be differences between the SAR levels of various phones and at various positions, they all meet the government requirement for RF exposure.

Before a new model is available for sale to the public, compliance with the regulations must be shown.

*The SAR limit recommended by international authorities (CIPRNI) for mobile phones used by the public is 2 watts/kilogram (W/Kg) averaged over ten grams of body tissue. The standard incorporates a substantial margin of safety to give additional protection for the public and to account for any variations in measurements.

**In the United States and Canada, the SAR limit for mobile phones used by the public is 1.6 watts/kilogram (W/kg) averaged over one gram of body tissue

I) Legal Advice

In addition to this User Guide, you must read the General Conditions and Vega service Subscription Form, provided by your local operator. These documents contain important information and legal notices that you must be aware of, and accept before activating Vega.

1. Intellectual property

PATENTS AND COPYRIGHTS

The technologies and methods used in Vega are protected by patents pending worldwide and are the property of Everon Oy or its subsidiaries.

All softwares contained in the Vega system are protected by patents or copyright. Copying, modifying or reverse engineering is strictly prohibited and may lead to prosecution.

TRADEMARKS

Everon and Vega are registered trademarks of Everon Oy, or its subsidiaries. Other logos or products of Everon Oy or its subsidiaries, whether protected or not, are the property of Everon Oy, or its subsidiaries. You agree not to display or use in whatsoever manner said trademarks without the prior written consent of Everon Oy. Other products and company names mentioned in this User's Manual or on the websites belonging to Everon are either trademarks pending or registered trademarks that are the property of their respective holders.

2. Statement of compliance

CE MARKING

Everon hereby attest that the Vega product complies with standards ETSI EN 301-357-1, ETSI EN 300-220-1, ETSI EN 301-489-3, EN 60950-1, EN 50392:2004, EN 60950-1, EN 301 511, 3GPP 51.010 1, in accordance with the provisions of directives EMC 89/336/EEC, 73/23/EEC and R&TTE 1999/5/EC. For more details, please contact us.



FCC STATEMENT

This device complies with Part 15 of the FCC Rules. Operation is subject to the following two conditions: (1) this device may not cause harmful interference, and (2) this device must accept any interference received, including interference that may cause undesired operation. Any changes or modifications not expressly approved by Medical Intelligence Canada could void the user's authority to operate the equipment.



NOTE: This equipment has been tested and found to comply with the limits for a Class B digital device, pursuant to part 15 of the FCC Rules. These limits are designed to provide reasonable protection against harmful interference in a residential installation. This equipment generates, uses and can radiate radio frequency energy and, if not installed and used in accordance with the instructions, may cause harmful interference to radio communications. However, there is no guarantee that interference will not occur in a particular installation. If this equipment does cause harmful interference to radio or television reception, which can be determined by turning the equipment off and on, the user is encouraged to try to correct the interference by one or more of the following measures:

- Reorient or relocate the receiving antenna.
- Increase the separation between the equipment and receiver.
- Connect the equipment into an outlet on a circuit different from that to which the receiver is connected.
- Consult the dealer or an experienced radio/ TV technician for help

Vega	Vega Base
FCC ID: YLO201001	FCC ID: YLO201002
IC: 9150A-201001	IC: 9150A-201002
Model: URG-BRA-002	Model: URG-BAS-002

Reminder

SIM NUMBER: _____

SERIAL NUMBER: _____

PASSWORD: _____

CONTACTS: _____

everon™

Everon Oy

Vakiotie 9

FIN-21420 Lieto

tel. +358 207 920 702

E-mail support@everon.net

Internet www.everon.net