



Multicom 1550nm Optical Transmitter

MUL-1550TX-1000-XX



User Manual v.8

www.multicominc.com | 800-423-2594 | 407-331-7779

1076 Florida Central Parkway, Longwood, FL 32750



Multicom 1550nm Optical Transmitter

MUL-1550TX-1000-XX

SAFETY NOTIFICATION



The Multicom 1550nm Optical Transmitter is classified as Class 1M per IEC/EN 60825-1/A2:2001. This product complies with FDA/CDRH, 21 CFR 1040.10 and 1040.11 except for deviations pursuant to Laser Notice No. 50 dated 26 July, 2001.

Viewing the laser output with certain optical instruments (for example, eye loupes, magnifiers and microscopes) within a distance of 100 mm may pose an eye hazard.

Laser power up to 12 mW at 1550 nm could be accessible if optical connector is open or fiber is broken. Lasers are Powered ON whenever the unit is powered.

- ⚠ **CAUTION: Use of controls, adjustments, and procedures other than those specified herein may result in hazardous laser radiation exposure.**

IMPORTANT SAFEGUARDS

Multicom strongly advises you to read the following safety instructions prior to installing and operating this equipment.

- **Read These Instructions First** – All safety and operating instructions should be read before installing or operating this equipment.
 - **Retain This Instruction Manual** – Safety and operating instructions must be retained for future reference.
 - **Ventilation** – Do not block or cover openings in this equipment. These are provided for ventilation and protection from overheating. **Maximum operating ambient temperature is 122°F (50°C).**
 - **Power Sources** – The Multicom MUL-1550TX-1000-XX Optical Transmitter must have a grounding resistance of <4 ohms. All power must be provided via a three wire, grounded power supply and cord. The mains circuit should be a dedicated, unswitched supply. Keeps the unit away from high voltage or other interference creating devices such as motors, compressors, etc.
 - **Grounding or Polarization** – This equipment is equipped with a polarized AC line plug. This plug will fit into the power outlet only one way. This is a safety feature. Do not defeat the safety purpose of a polarized plug. This equipment must installed and grounded per NEC regulations.
- ⚠ **CAUTION: For continued protection against risk of fire, replace circuit breakers/fuses (if necessary) with one of only the same type and rating.**
- ⚠ **Optical Output Safety: The Optical Transmitter units may emit harmful invisible laser radiation if powered on and the case is opened or the beam path is exposed.**



Multicom 1550nm Optical Transmitter

MUL-1550TX-1000-XX

Table of Contents

1.0 PRODUCT DESCRIPTION

2.0 PRODUCT FEATURES

3.0 1310nm OPTICAL TRANSMITTER LAYOUT

3.1 Front of Unit

3.2 Rear of Unit

4.0 CONTROLS, INDICATORS, AND ALARMS

4.1 Front Panel Operations

4.2 Start-up Main Menu

4.3 Unit Configuration Instructions

5.0 OPERATION NOTICE

6.0 WARRANTY AND REPAIR

7.0 PRODUCT SPECIFICATIONS



Multicom 1550nm Optical Transmitter

MUL-1550TX-1000-XX

1.0 PRODUCT DESCRIPTION

Multicom's MUL-1550TX-1000-XX Direct Modulated Transmitter delivers high performance signal transmission of NTSC, PAL, ATC, QAM, and related digital information for CATV and/or telephony applications. It is based upon custom high-linearity optically isolated DFB (Distributed Feedback) lasers, specifically designed for multi-channel AM video applications. The built-in control circuits provide an exceptionally low noise and inter-modulation characteristics. Automatic output power control, coupled with temperature stabilization provided by a thermoelectric cooler ensures maximum performance and longer laser life.

The units are packaged in slim 1.75-inch high (1RU), 19-inch aluminum rack-mounted enclosures. Each unit is fitted with redundant self-contained power supplies with 90-265VAC inputs.

All internal laser parameters and monitoring functions are under microprocessor control: the front panel displays status information related to laser operation, temperatures, and RF input.

2.0 PRODUCT FEATURES

- Transmits NTSC, PAL, ATC, and related digital information for CATV and/or telephony applications
- Available in a variety of output levels
- High linearity, optically isolated, distributed AM feedback DFB laser.
- 54-1000MHz RF input bandwidth
- Front panel laser diode and rear panel RF input test points (-20dB)
- Operation wavelength: 1550nm(ITUT option)
- Low RF drive levels enabled due to built-in RF amplifier and Automatic Gain Control
- Microprocessor-controlled diagnostics, front panel LCD display and controls
- Integrated SNMP network interface, *functional on units with optional S/W loading*
- Power supplies optional in VDC



Multicom 1550nm Optical Transmitter

MUL-1550TX-1000-XX

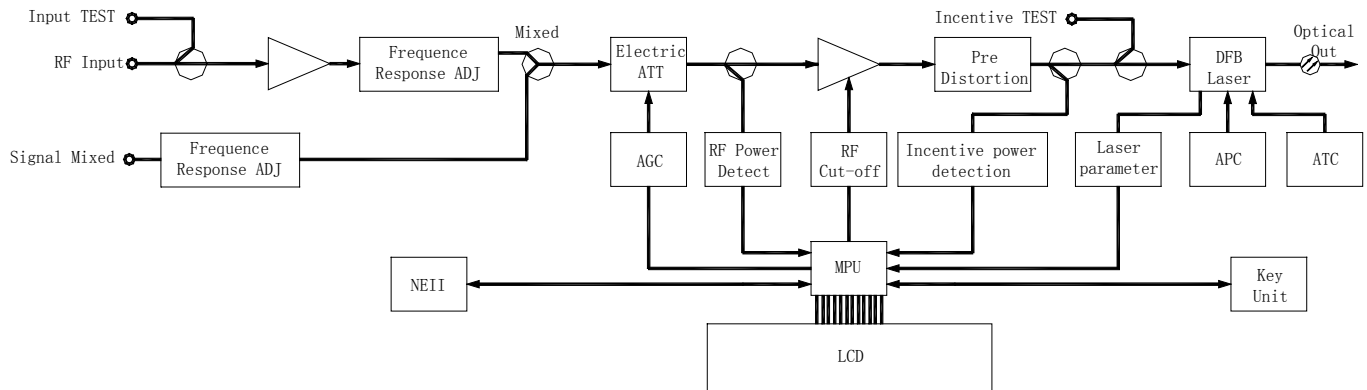

Figure 1 – Design Concept

3.0 1550nm OPTICAL TRANSMITTER LAYOUT

3.1 Front Panel Layout



Figure 2 – Front Panel

1. Laser On/Off switch
2. Status Alarm – green: okay, red: alert
3. LCD screen (see 4.3 for menu operation)
4. LCD menu ESC button
5. LCD menu LEFT button
6. LCD menu RIGHT button
7. LCD menu SET button
8. F-Connector test point – 20dB below “laser diode” level



Multicom 1550nm Optical Transmitter

MUL-1550TX-1000-XX

3.2 Rear Panel Layout

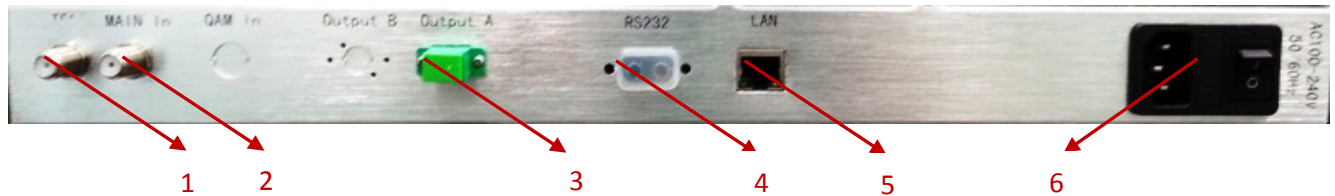

Figure 3 - Rear Panel

1. RF Test Input Port – 20dB below “main-port input” level
2. RF Main Input Port, *for 1GHz broadcast signals*
3. Fiber Optic SC/APC Connection
4. RS232 Port, *only functional on units with optional factory installed SNMP software*
5. LAN Port/SNMP Network Interface, *only functional on units with optional factory installed SNMP software*
6. Power Receptacle with ON/OFF flip switch

4.0 CONTROLS, INDICATORS, AND ALARMS

This section of the manual gives an overview of the available menus in the MUL-1550TX-1000-XX series Optical Transmitter. All instructions in section 4 refer to the image of the front panel (Fig 1). The user scrolls through the menus using the push buttons found on the front panel, these are located just to the right of the LCD screen.

4.1 Front Panel Operations

When the status LED indicator showing green, the unit is working properly; red LED indicates that the specific function is not working properly or set to off.

- A. With the power source turned on (power switches are located at the rear of the unit) and the unit working properly, the digital panel will display MULTICOM, INC. and the model number on the second line. The Laser LED alarm (2) will be red.
- B. In order to protect the laser, there is a time-delay function. After turning the laser on with the front panel “Laser On” switch, the laser will start to operate after about 2 seconds. The laser LED will turn from red to green and the LCD display will become brighter.



Multicom 1550nm Optical Transmitter

MUL-1550TX-1000-XX

4.2 Start-up Main Menu

Press **LEFT/RIGHT** button to scroll through the menu sequence below.

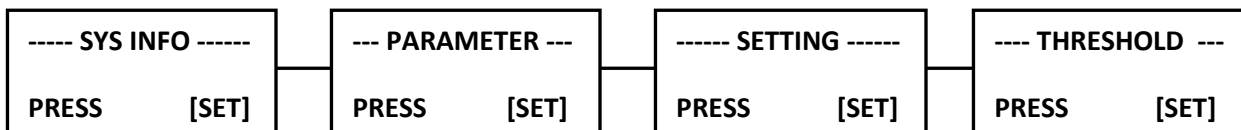

4.3 Unit Configuration Instructions

Menu # 1 – SYS INFO

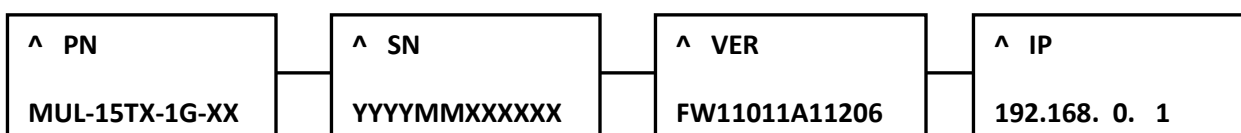

Displays part number, serial number, software version and IP address. Read for information only.

IP address is set by Telnet under username: sysadmin and password: admin.

Press ESC to go up one menu layer.

Menu # 2 – PARAMTER

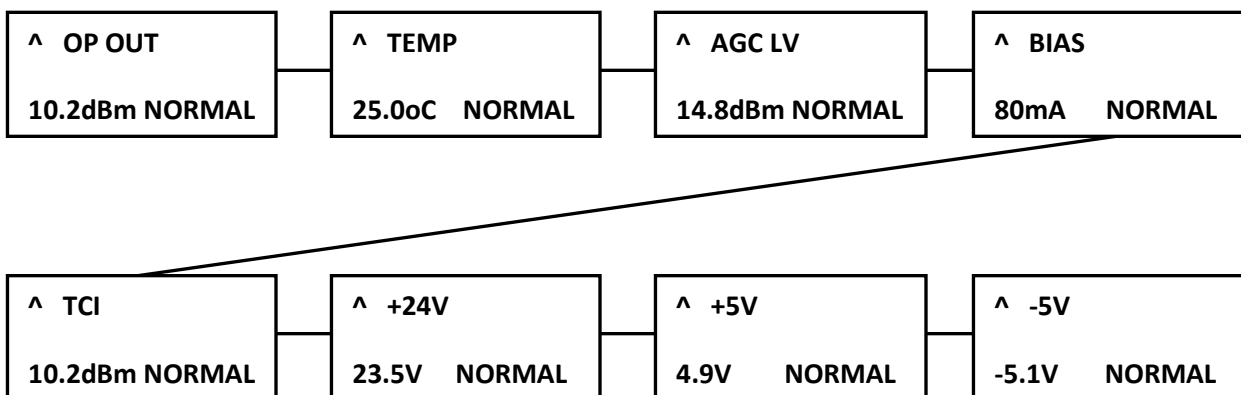

Displays optical output power, unit temperature, AGC (automatic gain control) level, bias current, TCI, and +24V, +5V and -5V power levels. Read for information only. If any parameter is outside NORMAL range, the display will show HIGH or LOW.

Press ESC to go up one menu layer.



Multicom 1550nm Optical Transmitter

MUL-1550TX-1000-XX

Menu # 3 – SETTING

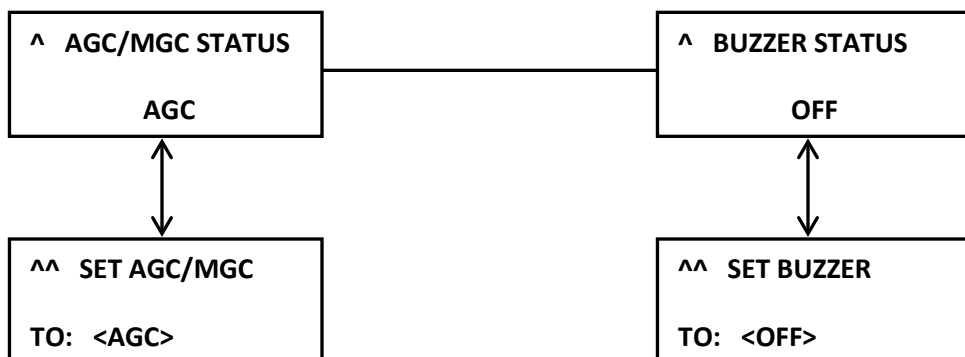

AGC is set as default mode. Only select the MGC mode if:

- Your application has a desired variation of the input level to be passed onto the receive end of your link
- Your application has an input that is too high a level or too low a level to allow AGC to control it
- In MGC mode, the attention level is adjustable between -6.0dB to +10.0dB in incremental of 0.2dB steps, by pressing LEFT or RIGHT buttons

Buzzer is set OFF in default mode. Set it ON or OFF when there is an alarm

Menu # 4 – THRESHOLD

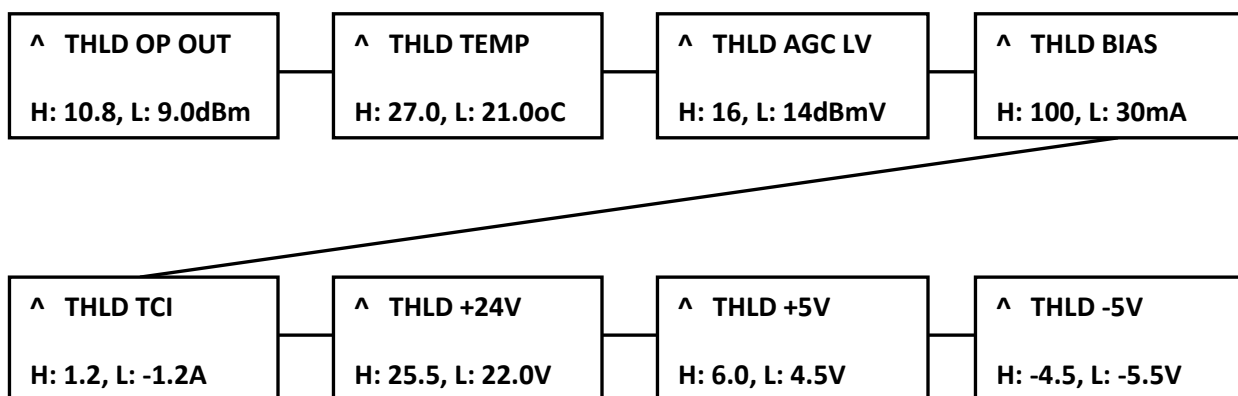

Displays status of factory default high/low threshold levels of monitoring parameters – optical output power, unit temperature, AGC (automatic gain control) level, bias current, TCI, and +24V, +5V and -5V power levels. Read for information only.

Press ESC to go up one menu layer.



Multicom 1550nm Optical Transmitter

MUL-1550TX-1000-XX

5.0 OPERATION NOTICE

- Changes to IP and RF Mode settings will be retained on power down/up.
- Use only Single Mode Fiber (SMF) optic cable (9/125 μ M). Multi-Mode Fiber (MMF) is incompatible with the equipment and will result in unacceptable performance and possible damage to the equipment.
- All fiber splices should be fusion-type splices. Avoid mechanical or compression type connections.
- For optimum performance, fiber runs should be made directly from the transmitter to the receiver. Minimize the use of adapters, patch panels, and additional points of failure and signal loss.
- In order to ensure return loss is maximum, use only SC/APC connectors. Clean and inspect connectors and fiber endfaces prior to installation, and every plug in/out cycle.
- Use only industry approved methods, materials, and solutions for cleaning.
- Do not turn on the transmitter alone or without a protector cover at the unit connector end, otherwise the laser can do harm, especially to eyes. This is especially critical because the laser is invisible.
- Always turn off the laser prior to making connections to the transmitter. Failure to do so may cause irreparable damage to the laser and transmitter.

6.0 WARRANTY AND REPAIR

The Multicom MUL-1550TX-1000-XX Optical Transmitter has a one year warranty and is subject to Multicom's standard warranty terms. There are no user serviceable components inside the unit. The warranty is void if the unit is opened or is damaged due to misuse.



Multicom 1550nm Optical Transmitter

MUL-1550TX-1000-XX

7.0 PRODUCT SPECIFICATIONS

	Specifications	Values	Notes
General	Operating temp. (°C)	0 – 50	32 – 122 °F
	Storage temp. (°C)	-40 – 85	
	Operating relative humidity (%)	5 – 95	Non-condensing
	Power supply (Volt AC)	100 – 240	
	Power consumption (W)	25	
	Size (WxDxH in inches)	19x14.25x1.75	
	Interface port	RJ45, RS232	
Optical	Wavelength (nm)	1530 – 1563	
	Output power (dBm)	6 and 10	Depending on model
	Optical connector	SC/APC	
RF	RF bandwidth (MHz)	45 – 1000	
	Input level (dBmV)	15 – 25	AGC
	Flatness (dB)	-0.75 – +0.75	
	Return loss (dB)	16	75Ω impedance
	RF connector (main input)	F type	
	CSO (dB)	-57	79 channel load, back to back at 0dBm receive power
	CTB (dB)	-63	

Product Series

Part#	Output Power	CNR
MUL-1310TX-1000-6	6 dB	≥50 dB
MUL-1310TX-1000-10	10 dB	≥50 dB