

Fluid Measurement



Technologies, Inc.

Precision Dilution System

User Manual



Precision Dilution System: User Manual

P/N 1976138

Copyright © Fluid Measurement Technologies, Inc. 2010. All rights reserved.

Address: Fluid Measurement Technologies, Inc.
4106 Hoffman Road
White Bear Lake, MN 55110-3708
USA

Phone Number: 651-762-7762
Fax Number: 651-762-7763
URL: www.fmtdevelop.com

The following is a history of the Precision Dilution System User Manual (part number 1976138).

Document Revision	Date and Changes
Version 1.0	Manual first release. March 2010
Version 1.1	Updated procedures and photos (reflect changes in PSL bottle size). December 2010.
Version 1.2	Added Appendices B and C and minor edits.
Version 1.3	Updated Appendices and minor edits.
Version 1.4	Name change and extensive revision. December 2014.

All trademarks appearing in this manual are the property of their respective owners

Fluid Measurement Technologies, Inc. may have patents or pending patent applications, trademarks, copyrights, or other intellectual property rights covering subject matter in this document. Providing you with this document does not give license to these patents, trademarks, copyrights or the intellectual property except as expressly provided in a written agreement from Fluid Measurement Technologies, Inc.

Limitation of Warranty and Liability

Fluid Measurement Technologies (FMT), Inc. offers a full 12-month repair or replacement warranty on all products sold. Warranty covers defects resulting from design or manufacturing. If any such product proves defective during this warranty period, FMT Inc., at its option, either will repair the defective product without charge for parts and labor, or will provide a replacement in exchange for the defective product. This warranty is offered on a return to factory basis, with return shipping expense expressly at the cost of the customer. FMT Inc. will pay the return shipping on any materials repaired or replaced. Any repaired or replaced item assumes the remainder of the initial warranty period. FMT Inc. warrants only to the extent of replacement or repair of our products, and does not assume any responsibility for consequential damages. No warranty is offered on accounts with past due balances. In order to obtain service under this warranty, Customer must notify FMT Inc., of the defect before the expiration of the warranty period and make suitable arrangements for the performance of service. The Customer shall be responsible for packaging and shipping the defective product to the service center designated by FMT Inc., with shipping charges prepaid.

This warranty shall not apply to any defect, failure or damage caused by improper use or improper or inadequate maintenance and care. FMT Inc. shall not be obligated to furnish service under this warranty a) to repair damage resulting from attempts by personnel other than FMT Inc. representatives to install, repair or service the product; b) to repair damage resulting from improper use or connection to incompatible equipment; or c) to service a product that has been modified or integrated with other products when the effect of such modification or integration increases the time or difficulty of servicing the product.

THIS WARRANTY IS GIVEN BY FMT INC. WITH RESPECT TO THE LISTED PRODUCTS IN LIEU OF ANY OTHER WARRANTIES, EXPRESS OR IMPLIED. FMT AND ITS VENDORS DISCLAIM ANY IMPLIED WARRANTIES OF MERCHANTABILITY OR FITNESS FOR A PARTICULAR PURPOSE. FMT RESPONSIBILITY TO REPAIR OR REPLACE DEFECTIVE PRODUCTS IS THE SOLE AND EXCLUSIVE REMEDY PROVIDED TO THE CUSTOMER FOR BREACH OF THIS WARRANTY. FMT AND ITS VENDORS WILL NOT BE LIABLE FOR ANY INDIRECT, SPECIAL, INCIDENTAL, OR CONSEQUENTIAL DAMAGES IRRESPECTIVE OF WHETHER FMT LLC OR THE VENDOR HAS ADVANCE NOTICE OF THE POSSIBILITY OF SUCH DAMAGES.

Service Policy

Knowing that inoperative or defective instruments are a detriment to our customers' satisfaction, our service policy is to give prompt attention to any known problems. If you discover any malfunction of the Precision Dilution System, contact FMT Inc. at 651-762-7762 (USA). If you are outside of the USA, please call your authorized distributor.

Table of Contents

Table of Contents	3
About This Manual	4
Intended Audience	4
Scope of User Manual	4
Definitions	4
Safety and Handling Procedures	5
Safety Signals	5
Warnings	5
Installing the Precision Dilution System	6
Equipment Needed	6
Procedures.....	6
Approximate Time.....	6
Precision Dilution System Schematic	7
Unpacking and Setting Up the Precision Dilution System	7
Unpack the Precision Dilution System.....	7
Attach the Peristaltic Pump	8
Connect the Drain Fitting.....	12
Connect to UPW	13
Turn on UPW, Flush the System, Power On, and Tension the Tubing	14
Connect a Particle Counter.	17
Operating the Precision Dilution System	19
Performing Dilutions.....	19
Dilution Calculations.....	21
Shutting Down the Precision Dilution System	23
Troubleshooting	24
Selecting the Correct Pump Tubing Size	24
Appendix A: Specifications	25
Appendix B: Peristaltic Pump Calibration	26
Appendix C: Calibration Verification for a PMS UDI50 In-situ Optical Particle Counter	29
Procedure	29
Results.....	29
Appendix D: Calibration Certificate Example	32

About This Manual

Intended Audience

The Precision Dilution System User Manual is intended to be used by qualified, trained, certified personnel including technicians and engineers.

Scope of User Manual

This User Manual contains detailed instructions for the set up of the Precision Dilution System.

Definitions

- PSL: Polystyrene Latex
- UPW: Ultrapure Water
- psi: pounds per square inch
- mL/min: milliliters per minute

Safety and Handling Procedures

When working with the Precision Dilution System:

- **Do not** remove any parts from the instrument unless this manual tells you to do so.

Safety Signals

The following warning symbols and labels are used in the documentation. Follow the procedures described in this manual to use the instrument safely.



Warning

Warnings are used to indicate that unsafe use of the instrument could result in irrevocable damage to the instrument.

Note

Notes are used to indicate important information about the Precision Dilution System.

Warnings



Please familiarize yourself with the following warnings before operating the Precision Dilution System:

- The Precision Dilution System must be used following the manufacturer's specifications or safety cannot be guaranteed.
- All service work must be performed by trained, qualified technicians. Only qualified service technicians should remove the Precision Dilution System cover.
- Follow the instructions for all inlet and outlet connections - incorrect connections will cause the Precision Dilution System to malfunction.
- Any air or nitrogen supplied to the Precision Dilution System must be filtered (particle-free), dried, oil-free and regulated at 138 kPa (20 psi).
- When not in use for dilutions, leave the Precision Dilution System running, with water flowing through it at the lowest flow rate (78.6µ), to prevent potential contamination. **If standing water is allowed to stay stagnant in the system, you risk bacterial contamination.**
- The Precision Dilution System must be drained before it is shipped. Do not ship an undrained Precision Dilution System - doing so will invalidate the warranty.
- Do not subject an undrained Precision Dilution System to freezing temperatures. Doing so will damage the instrument and invalidate the warranty.

Installing the Precision Dilution System

Follow the instructions in this section of the manual to install the Precision Dilution System

Equipment Needed

- ¼ inch PFA tubing
- ¼ inch flaring tool
- ½ inch plastic drain tubing
- Flaretek nuts
- ¼ inch wrench
- Philips driver #2
- Stopwatch
- Scale with readability to 0.01 grams
- Glass or plastic beaker
- 125mL plastic bottle

Procedures

Refer to the flow diagram on page 7 as you install and operate the Precision Dilution System.

Following is an overview of the steps required to get your Dilution System up and running:

1. Attach the peristaltic pump.
2. Connect the Drain fitting.
3. Connect to UPW water.
4. Turn on the UPW, flush the system, power on, and tension the injection tube.
5. Connect to a particle counter.

Please read the detailed instructions for each step, beginning on page 7, before you set up the Dilution System.

Approximate Time

Completing all the assembly procedures will take approximately 30 minutes.
Note: The Dilution System must be flushed for 30 minutes before use to remove any contamination.

Precision Dilution System Schematic

Figure 1: Precision Dilution System Flow Schematic

Precision Dilution and Injection System

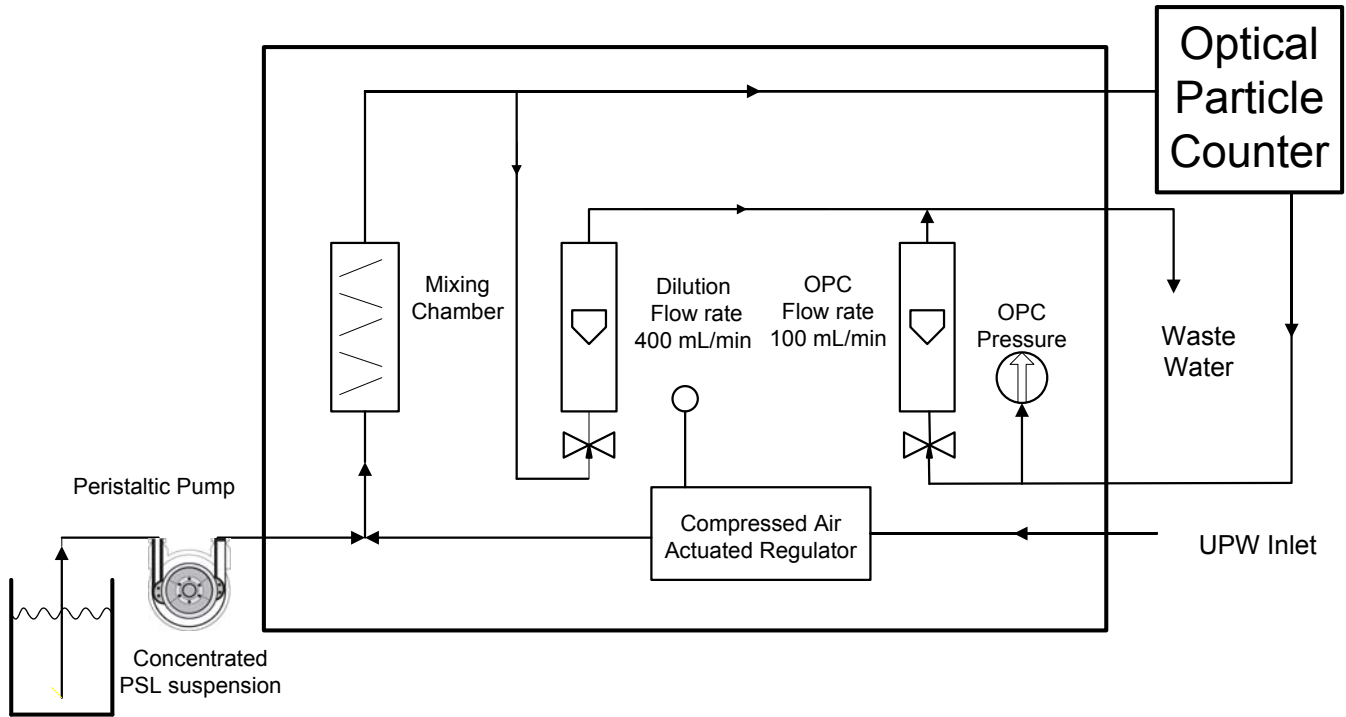

Unpacking and Setting Up the Precision Dilution System

Unpack the Precision Dilution System

To unpack the Precision Dilution System, follow these instructions:

1. Carefully remove the Precision Dilution System and all its components from the packing case. Save the original packing materials for use when returning the Dilution System to FMT Inc.
2. Check that all the items listed in Table 1 were included. If any of the items are missing, or damaged, please call Fluid Measurement Technologies, Inc. at 651-762-7762

Table 1: Precision Dilution System Packing List

Part Number	Description	Quantity
1026138	Precision Dilution System Main Body and Mounting Bracket	1
1021000	Ismatec Precision Metering Peristaltic Pump, Cassette Cartridge, Cassette Cartridge with Pressure Lever, and Instruction Manual	1
1330001	Power Supply Cable (USA only)	1
1021050	0.64 Tygon Tubing	1
1022490	OPC Bypass Tubing	1
1022495	CDA/N ₂ Adapter Fitting	1
2002020	125mL Wash Bottle	1
2002000	8 mm bottle cap with hole	1

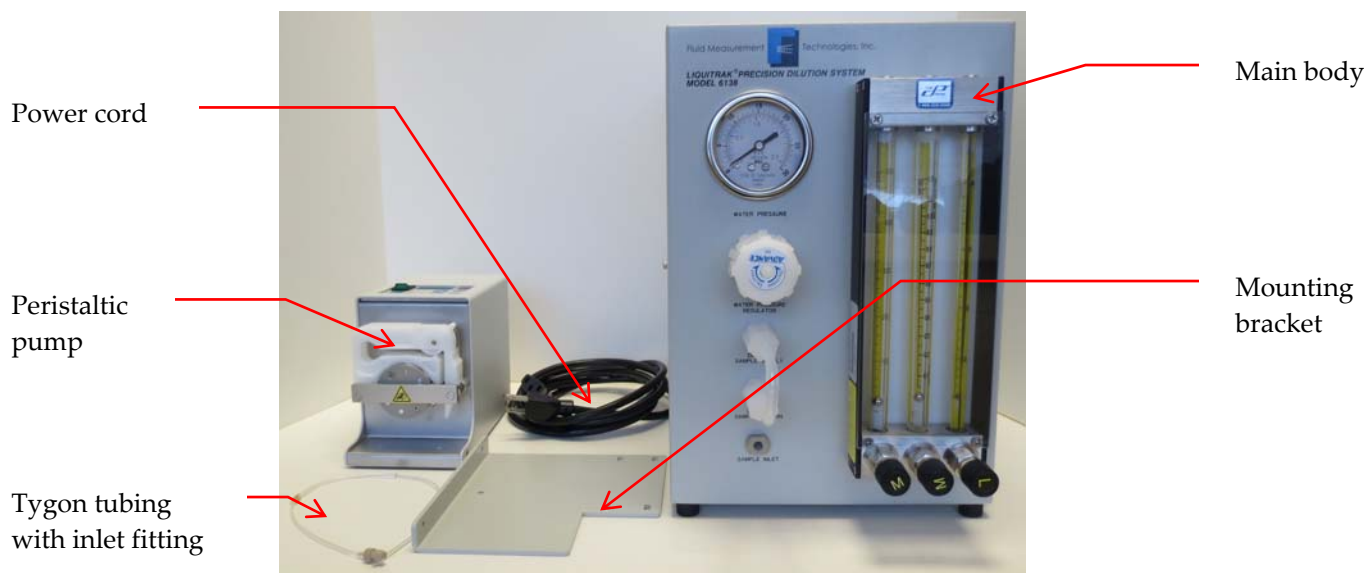

Attach the Peristaltic Pump

The peristaltic injection pump supplied with the Dilution System is preset to a flow rate of 0.100 mL/min (to within $\pm 2\%$) and should not require re-calibration upon initial installation. Check the pump calibration once a year (after the initial installation) following the procedures described in Appendix B.

To attach the pump, follow these instructions:

1. Remove the plug from the **SAMPLE INLET**.
2. Attach the inlet fitting on the supplied Tygon tubing to the **SAMPLE INLET** and finger tighten. The fitting should be snug.

Precision Dilution System: Installation

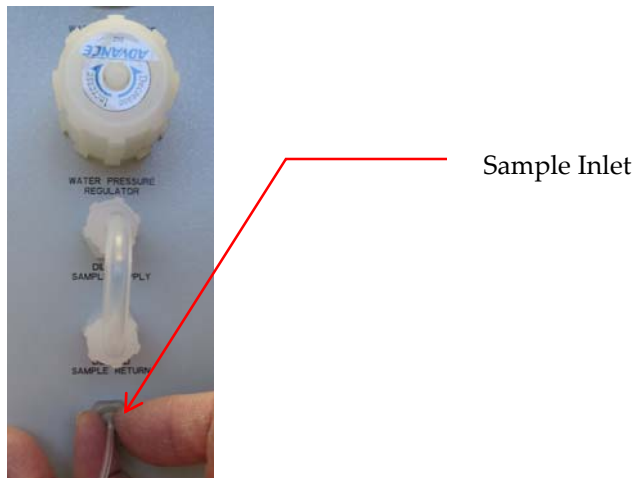

3. Lay the main body on its side on the workbench. Using a Philips screwdriver, unscrew the four screws used for the mounting bracket.

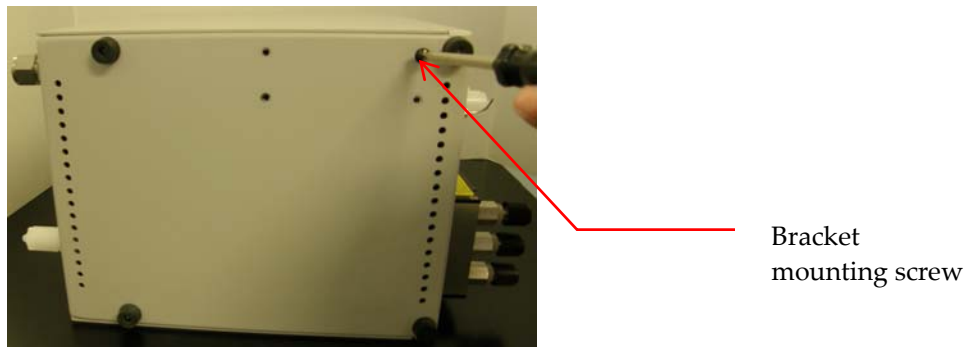

4. Screw the mounting bracket in place using the screws you removed and return the main body to a vertical position.



5. Remove the two screws from the left-hand side of the peristaltic pump and reserve for use in step 7.

Precision Dilution System: Installation

6. Place the pump on the mounting bracket.



7. Insert the screws you removed in step 5 onto the side of the bracket to hold the pump securely in place.

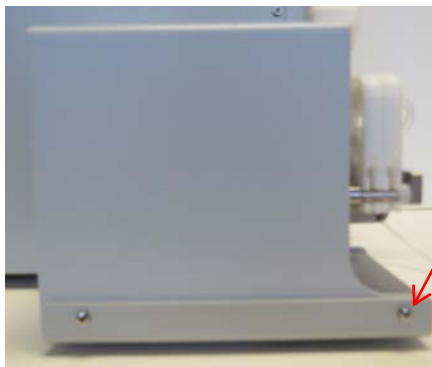

Pump mounting
screw

8. Remove the front tube holder (with adjustable pressure lever) from the pump by pushing in the tab (to the left) and lifting the holder up.



Front tube
holder

Tab

Precision Dilution System: Installation



9. Take the supplied Tygon tubing and slot it into the tube holder. Place the orange tube positioner on the far right of the tubing against the tube holder.



Orange tube positioner

10. Stretch the tubing and put the white positioner into the far-left slot.

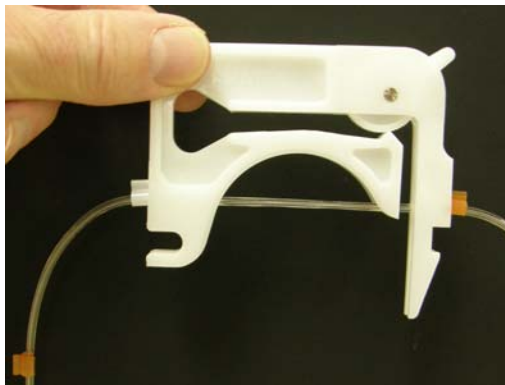

Precision Dilution System: Installation

11. Hook the tube holder onto the pump and snap down into place.



Connect the Drain Fitting

Note: FMT Inc. does not supply the tubing for connecting the Dilution system to the water supply.

1. Remove the red drain cap from the **Drain** fitting and discard.



2. Unscrew the ½ inch Swagelok nut and remove the stainless steel ferrules.
 3. Push the ½ inch plastic tubing (not provided) into the Swagelok nut.
 4. Slide the smallest ferrule onto the tubing, followed by the largest ferrule.
- Warning:** The ferrules must be fitted in the correct order and orientation (shown in the photo below).

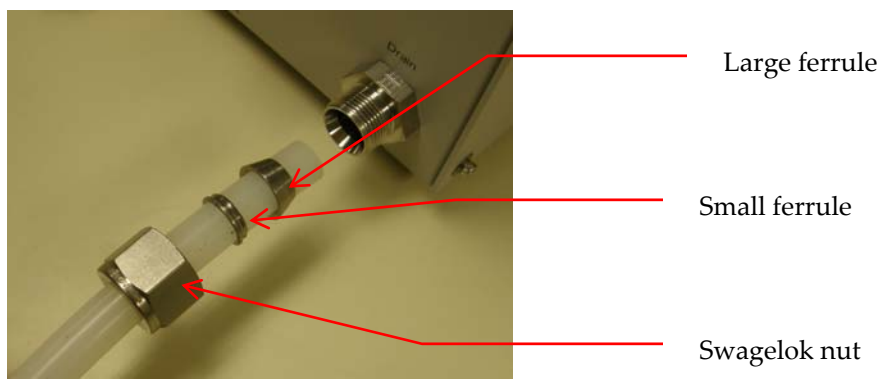

Precision Dilution System: Installation

5. Push the end of the tube as far into the **Drain** fitting as you can.
6. Slide the nut onto the ferrules, engaging the threads. Hand-tighten until you feel resistance.
7. Using a wrench, tighten the nut up to 1/2 turn.
Warning: Do not turn more than half a turn. Too much torque will spin the bulkhead.



Connect to UPW

1. Remove the Flaretek nut from the **Water Inlet** and push out the cap.

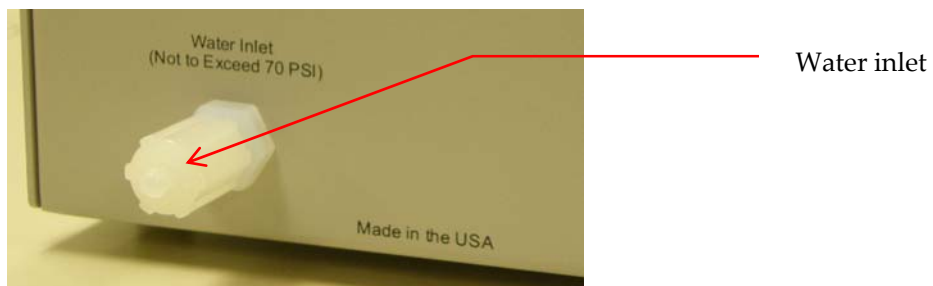

2. Take a length of 1/4 inch PFA tubing (not provided) and flare one end.
3. Push the nut you removed from the **Water Inlet** onto the other end of the tubing.
4. Push the flared end of the tube onto the Water Inlet fitting.

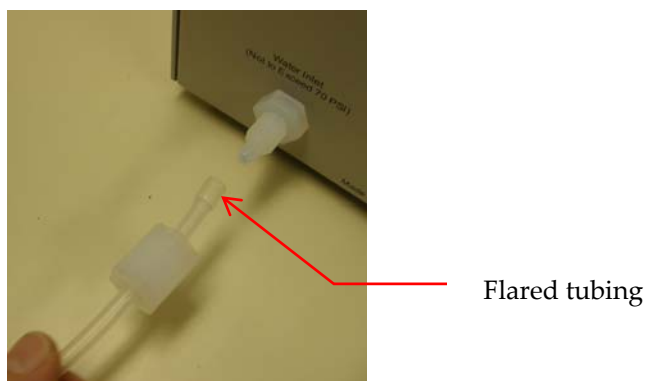

Precision Dilution System: Installation

5. Hand-tighten the PFA nut over the **Water Inlet**.



Turn on UPW, Flush the System, Power On, and Tension the Tubing

1. Remove the Flaretek nuts from the **DILUTED SAMPLE SUPPLY** and **DILUTED SAMPLE RETURN** ports.
2. Take the provided OPC Bypass tubing and attach to **DILUTED SAMPLE SUPPLY** and **DILUTED SAMPLE RETURN** ports. Note: Instead of the provided OPC Bypass tubing, use any preferred PFA tubing that your procedures for OPC calibration require.

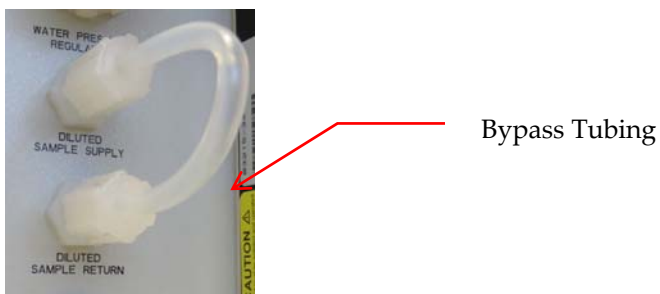

3. Check that the positioning lever on the injection pump tube holder is rotated clockwise to the down position. Then place the end of the Tygon tubing into an empty beaker.
4. Turn the **WATER PRESSURE REGULATOR** counter-clockwise to close the regulator.

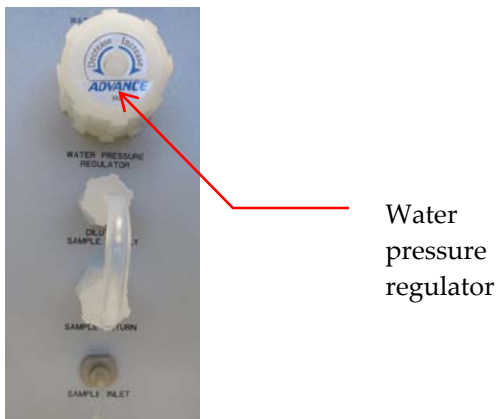

Precision Dilution System: Installation

5. Turn on the water.
6. Partially open the needle valve beneath the Dilution flow meter. Two turns in a counter-clockwise direction should be sufficient.



Dilution
flow meter
needle valve

7. Turn the Water Pressure Regulator in a clockwise direction. At the same time, turn the dilution valve to maintain a flow of 100 mL/min. Slowly increase the water pressure to read 15 psi. Water should now flow through the Precision Dilution System. Water will flow from the **Drain** port on the back panel. It will also flow from the **SAMPLE INLET** port through the Tygon tubing and into the beaker. Check the Dilution System for leaks (there should not be any). If there are leaks, check inside the instrument for loose fittings. (Note: There is no potential for electric shock.)
8. Plug the supplied power cable into the power socket on the back of the pump.
9. Press the Power button on the pump. You should see the green power light and pump flow rate diode. The display reads 0.100 mL/min.



Display

Flow Rate Diode

Power Button

Precision Dilution System: Installation

10. Press the **Settings ▲** arrow to increase the flow rate on the pump to between 3 and 4 mL/min. Allow the water to flow into the beaker for one minute to clean out the tubing.
11. Press the **Settings ▼** arrow to reset the flow to 0.100 mL/min.
12. Confirm that the water pressure is still at 15 psi and the Dilution flow meter is still at 100 mL/min. Pull the positioning lever on the injection pump tube holder up until the flow through the Tygon tubing just ceases and then continue to lift it for two more clicks. There should now be no water flowing into the beaker.

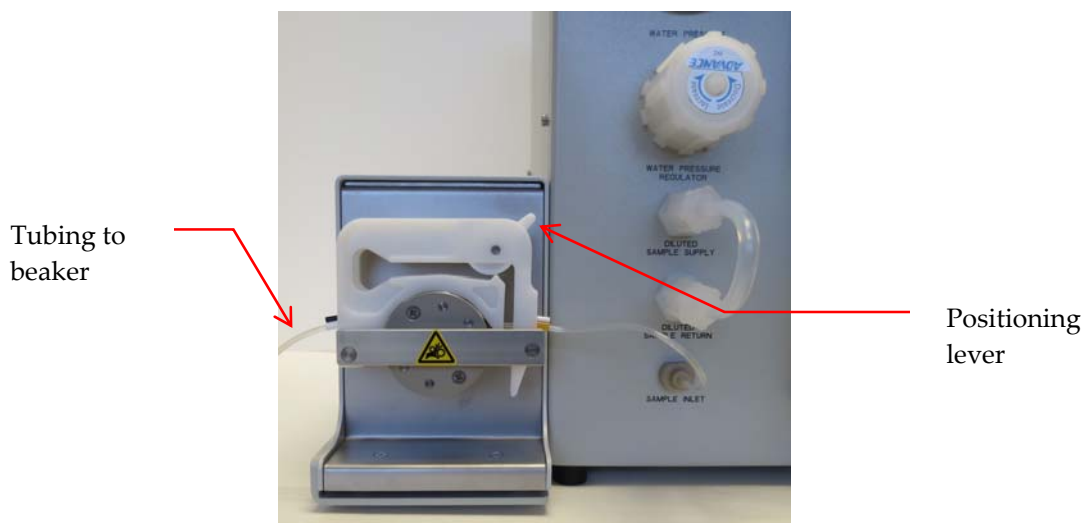

13. Fill the beaker with UPW and insert the Tygon tubing with the end of the tubing below the surface of the water.
14. Press **RESET** to set the flow out of the pump (it should now be flowing from the beaker to the pump).
15. Allow the system to rinse up for another 30 minutes to flush any contaminants out of the Dilution System. Flush at a minimum flow rate of 100 mL/min (or the particle counter manufacturer's recommendations) through the particle counter and the Dilution System. Note: It is helpful to flush through the tubing that will be used to connect the Dilution System to the particle counter and through the injection pump's Tygon tubing.
16. As necessary re-adjust the Water Pressure Regulator to 15 psi and the flow meter valves to the flow rate recommended by your particle counter's manufacturer. (See following instructions.)
17. Press **RUN/STOP** to stop the pump.

- Using the provided wash bottle, wash the end of the injection tubing with UPW water to remove any potential contaminants. Note: The tubing will eventually be inserted into the PSL standard and **MUST** be clean or it will contaminate the standard.



Connect a Particle Counter.

- Turn off the water supply.
Warning: If you do not turn off the water, you risk flooding your work area! If you do not want to repeatedly turn off the water supply to connect and disconnect a particle counter, install isolator valves over the **DILUTED SAMPLE SUPPLY** and **DILUTED SAMPLE RETURN** ports. Note: FMT Inc. does not provide isolator valves.
- Remove the Bypass tubing from the **DILUTED SAMPLE SUPPLY** and **DILUTED SAMPLE RETURN** ports on the front panel.
- Attach a particle counter following the manufacturer's instructions. To gather data, connect the particle counter to a data logging device following the manufacturer's instructions.
- Turn on the water.
- Recommended flow rates for particle counters vary. The following instructions use a PMS M50 particle counter, with a recommended flow rate of 100 mL/min, as an example.
The readings should be taken from the center of the metal balls.
You can use an external flow meter, or the flow meter built into your particle counter, to adjust the flow rate through the particle counter.

Precision Dilution System: Installation

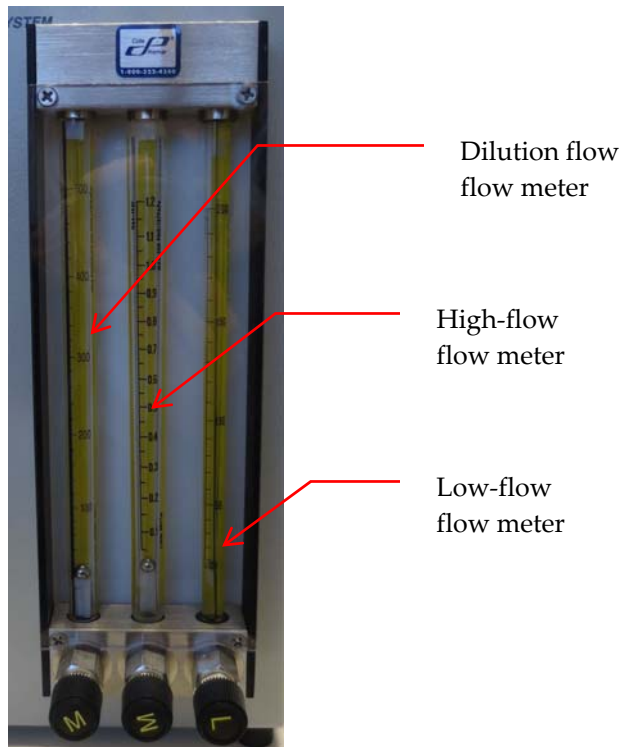

6. For a low-flow rate particle counter, such as the PMS M50, (< 100 mL/min flow rate), the total flow through the 100 mL/min flow meter and the Dilution flow meter should be 500 mL/min. The flow rate through the 100mL/min flow meter should be at the particle counter manufacturer's recommended flow rate, and the remaining flow should pass through the Dilution flow meter. Note: There should be no flow through the 1000mL flow meter. Changes in the total flow rate will affect the water pressure which you may have to adjust to 15 psi.
7. For a high-flow-rate particle counter, such as the PMS UDI50 (which has a flow rate of 1000 mL/min), increase the flow through the high-flow-rate flow meter to 900 mL/min. The flow through the low-flow-rate flow meter should be 100 mL/min for a total flow of 1000 mL/min. The Dilution flow meter should read 0 mL/min.

Operating the Precision Dilution System

Performing Dilutions

PSL verification standards are available from Fluid Measurement Technologies, Inc. in 8mL capacities.

PSL sizes are displayed on the top of the verification standards boxes. We recommend that you begin with the smallest PSL standard sizes in the box you're using and progress to the larger PSL sizes. : Each box contains 8 bottles of one size.

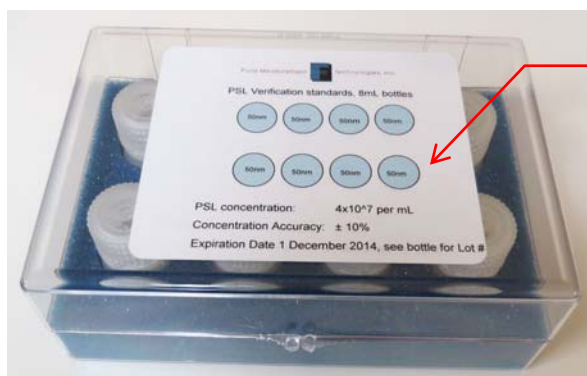

PSL Standards

Follow these steps to perform dilutions:

1. Begin with a bottle taken from the box with the smallest PSL standard size.
2. Rinse the inside of the cap (provided) that has a hole in the center with UPW from the rinse bottle.

Warning: You must flush the cap with clean water before placing it on a verification standards bottle. The verification standards bottles are filled almost to the top, therefore the cap collects PSL spheres as it is moved from bottle to bottle. Flushing with clean water ensures that PSL spheres of one size do not contaminate a bottle containing a different size.



Cap with
central hole

Precision Dilution System: Operation



3. Remove the cap from the first standard bottle you want to use and replace with the cap with a hole in the center.
4. Wash the end of the injection tubing with UPW water to remove any potential contaminants.

Warning: The tubing will be inserted into the PSL standard and **MUST** be clean or it will contaminate the standard. You should perform this procedure **every** time you use a different verification standards bottle.



5. Push the injection tube through the hole in the cap until the tube touches the bottom of the bottle.



Tube placed in standards bottle

6. Calculate the dilution rate and pump speed (see example of such a calculation in Dilution Calculations on page 21).
7. Perform a dilution with the standard. In this instance, an 8 mL verification standards bottle will allow a total of 40 minutes of calibration time. However, 15 minutes is sufficient time to obtain a stable reading on the particle counter. Therefore, one 8 mL standard bottle can be used for validating the calibration of two particle counters. Results for a UDI50 challenge are shown in Appendix C.
8. Before beginning the next challenge (with a bottle from the box of the next PSL size), rinse the Precision Dilution System for 5-10 minutes to obtain a stable background. During the rinse, run the injection pump in reverse mode (press the Reset button) so that water flows from the dilution system into a beaker. This will remove any PSL particles from the Tygon tube.
9. When the rinse is finished, press Reset on the pump.
10. Remove the cap from a bottle in the box of standards for the next size.
11. Remove the cap with a central hole from the verification standards bottle you used for the previous dilution. Rinse the cap (see step 2) and place it on the next standard bottle.
12. Wash the end of the injection tubing with UPW water to remove any potential contaminants. Push the injection tube through the hole in the verification standards bottle cap until it reaches the bottom of the bottle.
13. Repeat steps 6-11 until you have used a bottle from each of the verification standards sizes.

Dilution Calculations

Ideally, you should challenge a particle counter at 80% of the maximum concentration recommended by the manufacturer.

At an injection flow rate of 0.1 mL/min, the 4mL verification standards bottle can be used for 40 minutes. However, 15 minutes is sufficient time to obtain a stable reading on the particle counter. Therefore, one 4 mL standard bottle can be used for validating the calibration of two particle counters.

Example:

The PMS M50 will require a target concentration of 8,000 particles/mL. Therefore, a starting concentration of 4×10^7 PSL/mL, injecting at 0.1 mL/min into a total flow rate of 500 mL/min, gives a final concentration of 8,000 PSL/min.

$$\frac{0.1 \times 4 \times 10^7}{500} = 8000$$

Precision Dilution System: Operation

For a PMS UDI50, the maximum concentration recommended by the manufacturer is 10,000 particles/mL. To achieve the challenge concentration of 8,000 particles/mL, at a dilution of 1000 mL/min (the flow rate for the UDI50), the injection speed must be increased to 0.2 mL/min. In this instance, an 8 mL verification standards bottle will allow a total of 40 minutes of calibration time. Results for a UDI50 challenge are shown in Appendix C (see page 29).

Shutting Down the Precision Dilution System

Warning: Do not leave the Precision Dilution System full of water with no flow through the instrument. If you do, you run the risk of bacterial growth and serious contamination. If you will not be operating the Precision Dilution System for 24 hours or more, you have two options:

- Leave the Dilution System flushing with UPW at a total flow of 300 mL/min (allow a flow of 100 mL/min through each of the flow meters). Then run the injection pump in reverse (flow out of the dilution system) at the lowest flow rate.
- Purge the system completely with CDA or filtered N₂ until all residual water is removed (especially through the OPC ports). Release tension on the injection pump tubing and allow CDA/N₂ to purge the injection tube. Do not re-tension the tubing until you are ready to operate the system again.

To shut down the Precision Dilution System completely, follow these instructions:

1. Flush any PSL from the dilution system by running UPW water through it at a high flow rate for one minute. At the same time, run the injection pump backwards at a flow rate of 3-4 mL/min, with the beaker in place to collect the water.
2. Press the power button to turn off the peristaltic pump.
3. Turn off the water supply.
4. Turn the Water Pressure Regulator counter clockwise and open the three flow meter valves.
5. Release the tension on the injection tubing by releasing the tensioning lever on the injection pump.
6. Attach the supplied bypass tubing to the **DILUTED SAMPLE SUPPLY** and **DILUTED SAMPLE RETURN** ports.
7. Using the supplied CDA/N₂ Adapter Fitting, blow out the Dilution system with CDA or Nitrogen at 5-10 psi for 24 hours to completely dry out the instrument.
8. Disconnect all tubing and cap off all inlets/outlets.
9. If you are shipping the instrument, disassemble it by reversing the instructions in the Installation section of this manual.

Troubleshooting

Selecting the Correct Pump Tubing Size

The default size for the pump tubing is 0.13 mm. The Precision Dilution System is supplied with a pump tubing size of 0.64 mm. This size of tubing has been entered into the pump's memory at the factory. However, customers have reported that, as a result of a power outage or incorrect shut-down procedures, the Ismatec pump has reset to the default pump tubing size, resulting in the pump running much faster than usual.

Follow these instructions to check that the correct tubing size is entered into the pump's memory:

1. Switch the pump off and wait for five seconds.
2. While keeping the **settings ▼** button pressed, switch the pump on, wait a few seconds and then release the **settings ▼** button.
3. The display should read **C4CL** (the setting for Cycles).
4. Press the **settings ▲** button 7 times. The display should now read **tubE**.
5. Press **OK**. The display should read **0.64**. If this is the case, the pump has retained the correct tubing size and no adjustment is necessary. Press **escape** twice to revert to normal pump operation.
6. If the display reads the default setting of **0.13**, press the **settings ▲** button 7 times to scroll through the available tube sizes (0.13, 0.19, 0.25, 0.38, 0.44, 0.51, 0.57, 0.64). When the display reads **0.64**, press **escape** twice to revert to normal pump operation.

Appendix A: Specifications

Working fluid	Ultrapure Water for diluting PSL and Colloidal Silica concentrations Note: Other solvents may be used with the Dilution System. Please consult the factory for guidance.
Ultrapure Water inlet	1/4 inch Flaretek®
Drain port	1/2 inch Swagelok®
OPC/LPC flow rates	10 to 1000 mL/min
Maximum dilution	20,000 (dependent upon UPW flow rate)
Maximum water temperature	35°C (95°F)
Pump tubing	0.64 mm ID Teflon®
Inlet water pressure	138 to 481 kPa, 20 to 70 psi (Note: a suitable water drain is required)
Critical wetted surface materials	PFA Teflon®
Ambient Temperature Range	15-35°C, 59-95°F
Ambient Relative Humidity Range	0-85%
Dimensions (WxDxH)	220 x 279 x 320 mm (8.7 x 11 x 12.6 inches). Width with shelf attached 321 mm (12.7 inches)
Weight	8 kg (17.5 lb)
Power	100 - 230 VAC 50/60 Hz, 20VA

Flaretek® is a registered trademark of Entegris, Inc.

Swagelok® is a registered trademark of Swagelok Company.

Teflon® is a registered trademark of E.I. DuPont de Nemours and Company, Inc.

Windows® is a registered trademark of Microsoft Corporation.

Specifications subject to change without notice.

Appendix B: Peristaltic Pump Calibration

Follow these instructions to check the pump calibration:

1. Connect the peristaltic pump to a power supply.
2. Press the power button to turn the pump on - you should see the green indicator light. The preset flow rate is 0.100 mL/min, but the pump displays the previous setting. The green **PUMP Flow rate** diode confirms that the pump is configured for flow rate. If the light is not on at the Pump/Flow rate position, press **MODE** until it is. If the flow rate is not 0.100, use the **settings ▲ ▼** arrows to adjust it.

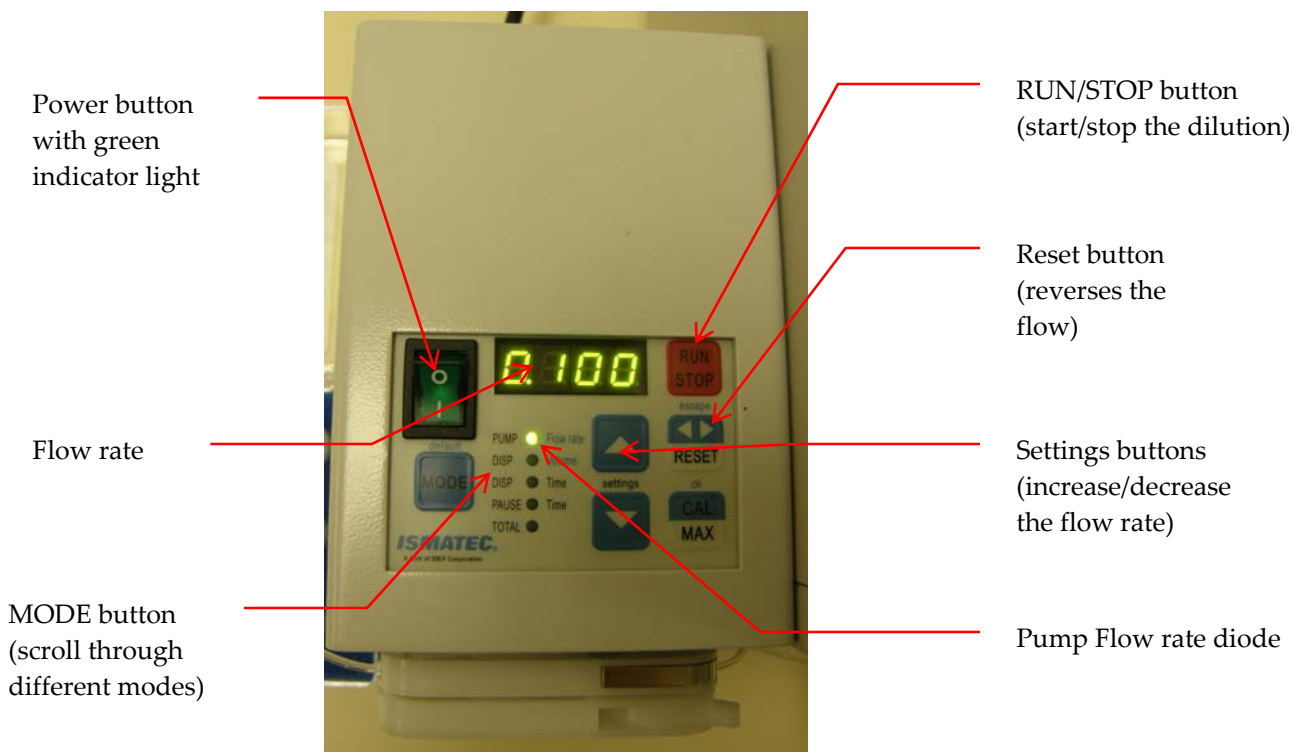

3. If the peristaltic pump is connected to the inlet fitting on the Precision Dilution System, disconnect the tubing.

4. Insert the inlet end of the injection tubing into a beaker or suitable collection vessel containing approximately 150 mL of UPW. Note: The tubing should touch the bottom of the container.



5. Note the direction of rotation of the pump; a clockwise rotation indicates flow into the dilution system and a counter-clockwise direction indicates flow exiting the pump. If necessary, press **RESET** to set the flow out of the pump (clockwise direction).
6. Weigh a plastic 60 mL bottle (not provided) and record the weight to 1/100 gram (0.0001 g).
7. Insert the outlet end of the injection tubing into the 60 mL bottle.
8. Press **RUN/STOP** to turn on the pump and start a stopwatch at the same time.
9. Run the pump for approximately 40 minutes. Press **RUN/STOP** to stop the pump and stop the stopwatch at the same time. Record the time the injection pump was operating. Note: There should be approximately 4mL of water left in the bottle.
10. Remove the bottle and place the end of the injection tubing into a beaker of clean water to prevent the tubing from becoming contaminated.
11. Weigh the 60 mL bottle and then calculate the flow rate (f):

$$f = \frac{\text{weight}(mg)}{\text{time}(min)}$$

If the pump calibration is accurate, the flow rate should be $\pm 2\%$ of 0.100 mL/min (assuming the water has a density of 1.00 g/mL). If not, use this calculated value to apply a correction to the peristaltic pump calibration as detailed in the worked example below.

- a. A worked example: The pump ran for 51 minutes and the difference in bottle weights was recorded as 4.9847g. Using the equation above the flow rate is calculated to be 0.0977mL/min (i.e. the pump is running 2.3% slow).

- b. To permanently enter a flow rate correction into the peristaltic pump, press the **CAL/MAX** button. The Display will now flash. Using the **Settings ▼** button, reduce the number displayed to 0.098. Press the **CAL/MAX** button again to enter the new calibration value. The display stops flashing and displays 0.100. Note the display will only flash for a few seconds to allow the new flow rate to be entered.
- c. To check the new flow rate calibration, repeat the steps 8 - 11.
- d. In this worked example the pump was run for 46 minutes and the weight change in the bottle was 4.5895g. Using the formula, this corresponds to a flow rate of 0.0998mL/min (i.e. the pump is running 0.2% slow, which is within the calibration requirements).

Appendix C: Calibration Verification for a PMS UDI50 In-situ Optical Particle Counter

This procedure demonstrates how a calibration verification of an optical particle counter with the Precision Dilution System Model 6138 can replace a routine factory calibration.

A Precision Dilution System Model 6138 was connected to a UDI50 with the following data logging conditions:

- Data logging began after a 30-minute rinsing period.
- All data was logged using PMS Facility Net software.
- Data collection was set for a 60 second, counting-time interval.
- All channels were logged as cumulative counts greater than their respective size channels.

Procedure

The UDI50 was challenged with four PSL verification standards at nominal sizes of 60, 70, 80, and 100 nm. Figure 4 in Appendix C shows an example of a PSL data certificate for the additional data on the actual PSL NIST-certified size from Duke Scientific. The initial concentration for each size of FMT PSL suspension is carefully adjusted to 4×10^7 PSL particles /mL. The Precision Dilution System was configured to deliver a concentration of 8,000 PSL particles/mL to the UDI50.

Each PSL challenge lasted for 15 minutes. There was a 10 minute clean-up time between each challenge.

Results

Table 4 shows the results of the calibration verification in time and counts. Figure 3 is a graph showing the results in a log of particle/mL versus time. Data for the 60, 70, and 80 nm challenges are shown as greater than the $0.05 \mu\text{m}$ channel. Data for the 100 nm challenge is shown for the $>0.10 \mu\text{m}$ channel because at 100 nm, the PSL spheres are large enough to pass through the edge of the laser defined-viewing volume and cause false counts in the $>0.05 \mu\text{m}$ channel.

Calculate the detection efficiency percentage for each challenge. Table 3 shows the detection efficiency percentages for this UDI50.

Table 3: Measured detection efficiencies for each of the 4 challenges.

PSL Challenge size (nm)	UDI50 detection efficiency (%)
60	7.9
70	33.9
80	60.4
100	100.0

These detection efficiency percentages can now be used as benchmark data for verifying the calibration of this particular PMS UDI50. If this PSL challenge procedure is repeated in 6, or 12, months, an acceptable limit on the change in detection efficiency (such as where each detection efficiency value drifts by no more than 15%) can be used to verify that the particle counter remains within calibration and does not need to be calibrated at the factory.

Figure 3: Log of particle/mL versus time.

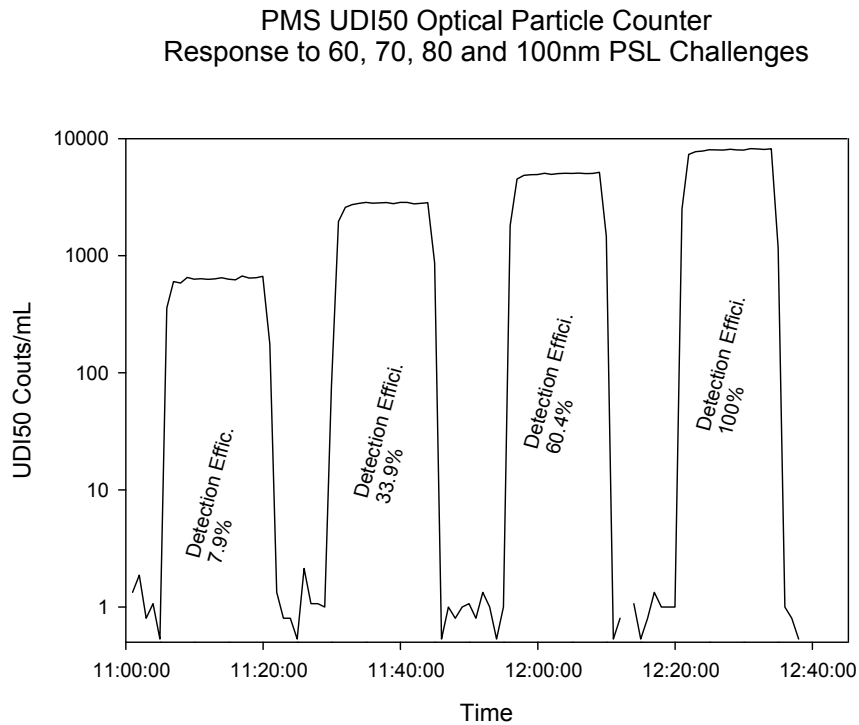

Table 4: Time and particle counts for four PSL challenges.

Time	>0.05 channel	Time	>0.05 channel	Time	>0.05 channel	Time	>0.10 channel
11:00:58	1	11:24:58	1	11:49:59	1	12:14:59	1
11:01:58	2	11:25:58	2	11:50:59	1	12:15:59	1
11:02:58	1	11:26:59	1	11:51:59	1	12:16:59	1
11:03:58	1	11:27:58	1	11:52:59	1	12:17:59	1
11:04:58	1	11:28:58	1	11:53:59	1	12:18:59	1
11:05:58	357	11:29:58	76	11:54:59	1	12:19:59	1
11:06:58	601	11:30:58	1961	11:55:59	1808	12:20:59	2502
11:07:58	583	11:31:58	2590	11:56:59	4506	12:21:59	7340
11:08:58	651	11:32:58	2724	11:57:58	4854	12:22:59	7711
11:09:58	629	11:33:58	2795	11:58:58	4914	12:23:59	7828
11:10:58	634	11:34:58	2848	11:59:58	4925	12:24:59	8037
11:11:58	627	11:35:58	2807	12:00:58	5045	12:25:59	7999
11:12:58	633	11:36:58	2830	12:01:58	4949	12:26:59	7985
11:13:58	647	11:37:58	2839	12:02:58	5026	12:28:00	8089
11:14:58	630	11:38:58	2780	12:03:58	5056	12:28:59	8008
11:15:58	622	11:39:58	2847	12:04:58	5034	12:29:59	7996
11:16:58	669	11:40:58	2851	12:05:58	5058	12:30:59	8213
11:17:58	643	11:41:58	2770	12:06:58	5015	12:31:59	8141
11:18:58	647	11:42:58	2796	12:07:59	5041	12:32:59	8073
11:19:58	666	11:43:58	2836	12:08:59	5150	12:33:59	8176
11:20:58	175	11:44:58	868	12:09:59	1461	12:34:59	1164
11:21:58	1	11:45:59	1	12:10:59	1	12:35:59	0
11:22:58	1	11:46:59	1	12:11:59	1	12:36:59	1
11:23:58	1	11:47:59	1	12:12:59	0	12:37:59	1

Appendix D: Calibration Certificate Example

An example of a Certificate of Calibration is shown below (with FMT lot numbers). A brochure for the nanoparticle standards offered by Fluid Measurement Technologies can be downloaded at:

http://www.fmtdevelop.com/uploads/3/5/4/5/3545567/nanoparticlestandards_brochure.pdf

The FMT web-site (www.fmtdevelop.com) also has a copy of a paper entitled "Verifying the Calibration of Optical Particle Counters below 100nm" Blackford, Van Schooneveld and Grant, presented at the UPW Executive Forum, Phoenix, November 2010. This paper details the procedure for making PSL suspension of known concentration

Figure 4: Example of a Certificate of Calibration for 60 nm PSL Spheres

