THE TABLE OF CONTENTS

DESCRIPTION	2
TECHNICAL CHARACTERISTICS	2
ARRANGEMENT AND OPERATION.....	3
COMPLETE SET	3
MARKING.....	4
INTENDED USE	4
INTRAOCULAR PRESSURE MEASURE PROCEDURE.....	9
SAFETY MEASURES	11
MAINTENANCE SERVICE.....	11
ROUTINE MAINTENANCE.....	12
REPLACEMENT OF POWER SUPPLY ELEMENTS.....	12
PROBABLE FAULT CONDITIONS AND MEANS OF THEIR ELEMINATION	14
CHECK OF TONOMETER OPERABILITY ON THE TESTING UNIT	15
STORAGE AND TRANSPORTATION	18
ACCEPTANCE CERTIFICATE	18
MANUFACTURER'S WARRANTY	18
REPAIR	19

DESCRIPTION



TVGD-01 Tonometer of intraocular pressure (hereinafter as Tonometer) is design to measure intraocular pressure through the eyelid in the ranges from 5 to 60 mm. Hg without the application of anesthetic for both adult and children.

The Tonometer is delivered in a case being equipped with testing unit.

The case serves for the Tonometer carriage and storage during all period of its use. The testing unit serves to make periodic check of the Tonometer fitness for operation.

-  **Contraindications:**
- the pathological conditions of an upper eyelid (inflammatory diseases, scars, eyelid deformation);
 - sclera and/or conjunctivitis apparent pathology in the field of measurement.

TECHNICAL CHARACTERISTICS

- Overall dimensions,max. - 176x26x20 mm.
 - Weight of the device without power supply elements - 80g.
 - Tonometer operation climatic conditions:
 - air temperature: from +10 °C to +35 °C;
 - air relative humidity: up to 80% at temperature +25 °C.
 - Tonometer feeding is provided from two power supply elements of AAAA 1,5 V type.
 - Tonometer operating condition is provided by power supply voltage: from «» (3,3 V) to «» (2,0 V).
 - Measurement absolute error comes to ± 2 mm Hg. at pressure measurement in ranges from 5 up to 26 mm Hg., the relative error comes to 10 % of measured value at pressure measurement from 26 up to 60 mm Hg.
 - Tonometer max. current consumption: switched-off position - 60 mA; switched on position in the measurement "Waiting" mode - 4 mA; in measurement mode - 60 mA.
 - Time of one measurement, max.: 2s.
 - Tonometer external surfaces are steady to disinfection by chemical method with any disinfection solution allowed to application in medical practice for products made of plastic and metals, against infection of dermatophytosis type.
 - Tonometer readings with the application of control unit
mm. Hg.
(should be filled at product acceptance)
- Tonometer everage service life, min. - 5 years.

ARRANGEMENT AND OPERATION.

The performance of the Tonometer is based on the method of both elastic system, consisting of eye cornea covered with eyelid, and tonometer electromagnet vibrator free motion period measurement. Period of these free motions characterizes the eyeball elastic properties which depend on the size of intraocular pressure. The vibrator provides the system excitation and transformation of mechanical fluctuation into a signal of electric fluctuations. Internal eye pressure, displayed on the tonometer screen, is defined on the basis of this signal. The influence of eyelid on the result of measurement is excluded in the process of measurement due to eyelid statistic contraction by rod

Tonometer appearance (two positions) is shown in Fig 1.

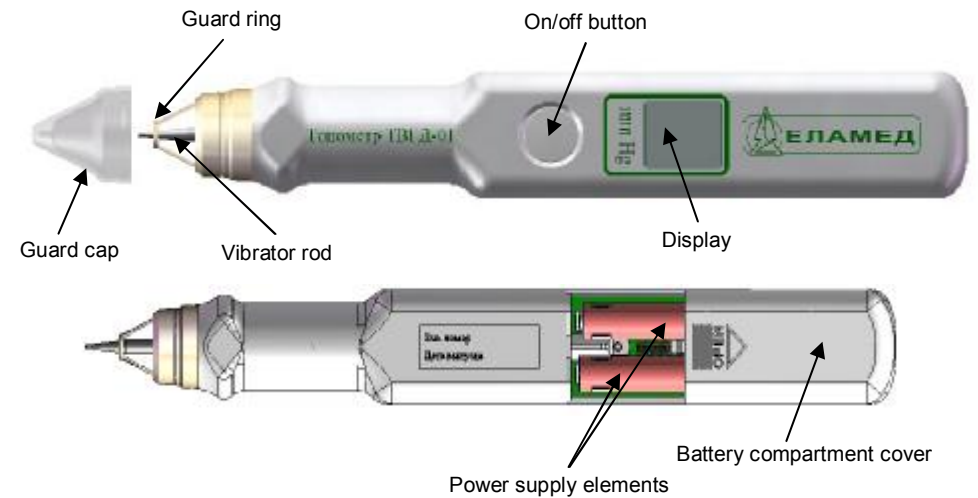

Fig 1

COMPLETE SET

Delivery set includes:

- TVGD-01 Tonometer of intraocular pressure:	- 1pc.
including:	
- cap	- 1pc.
- testing unit	- 1pc.
- case	- 1pc.
- power supply element AAAA 1,5V	- 2pcs.
- Operating manual	- 1pc.
- Educational film laser CD disk*	- 1pc.
- Consumer container	- 1pc.

* - supplied on customer request

The note - the other power supply elements with similar parameters on overall dimensions and voltage are supposed to be delivered.

MARKING

The mark denoting (according to ГOCT P 50267.0-92) necessity to consult the operational documents, according to IEC 60601-1:2005 it is the mark used in the operational documents as warning relating to product operation safety and efficiency;



“The working part of B type
The mark pointing out that the device electric shock safety is made of according to B type ГOCT P 50267.0-92(IEC 601-1-88).

INTENDED USE**Preparation of the Tonometer for use**

After the long storage and transportation at the temperature below +10 °C the Tonometer is to be kept in the premise at temperature from 10 to 35 °C at least for four hours.

Disinfection of the Tonometer plastic outer surfaces (if required) is to be carried out with its twice wiping by the calico napkin moistened in solution with 10-15 minute interval between wiping (the napkin should be wrung out in order to prevent disinfection solution from penetration inside a device).

Tonometer metal surfaces being in direct contact to patient eyelid (vibrator rod and guard ring) should be disinfected by calico napkin moistened in solution right before measurement

Operation order

Before taking measurement, first take the Tonometer out of case, then, turning it with rod upward, take the guard cap off. Press “on /off ” button momentarily to switch the Tonometer on.

The activation of the Tonometer is followed with sound signal and visual signal in the form of moving arrow in the display informing of the fact that the device is ready to start the procedure of measurement (Fig. 2).



Fig. 2

Right before measurement procedure of intraocular pressure (with the device switched on state) it is necessary to place the tip of measuring rod **through the upper eyelid** on the eye in area of sclera or cornea in the recommended or any point of an eye (an initial stage of measurement).

Then body of the device is necessary to be smoothly lowered 2-3 mm. downward. And at the same time you can feel the slight vibration as a result of activation

of dynamic force exposure. (the working stage of measurement. At measurement the Tonometer guard ring should not touch the eyes and should be placed 2-3 mm. over the eyelid.

Fig. 3 and 4 show both the initial and working stages of measurement process.



Fig. 3



Fig. 4

In a second after its lowering the Tonometer starts to generate sound signal indicating measurement readiness and displays measured value of intraocular pressure. The measurement, however, will be going on till you take the device up. To complete measurement you should smoothly take the device up. Measured value will be stored in the display till the device be switched off or up to the next measurement. To switch the device off you should momentarily press the on/off button.

a) readiness for operation
(when the device is switched on)

b) measurement mode



c) measurement termination

Fig. 5

The Tonometer display state at the device different operating mode are shown in the fig. 5

The property of the device to make intraocular pressure measurement continuously facilitates an effective training According to statistic you can obtain measurement practice in 10-20 minutes using for training such material as elastic dough or your finger-cushion. According to statistic data you can obtain measure-

ment procedure practice in 10-20 minutes using for training elastic dough or your finger-cushion.

Tonometer is able to carry out measurement at any accessible point of eye sclera or cornea through the eyelid. But there are recommended points to take measurement which are convenient both for doctors and patients (fig. 6 and 7).



Fig. 6



Fig. 7

The main conditions defining the measurement accuracy:

- perpendicular position of the Tonometer's rod to the eye surface;
 - tonometer body vertical position;
 - softness and exactness of action movements (with a speed about 2 sm. a second) when IOP measurement being conducted
- The requirement of softness and exactness of action motions is easily provided by the hand, with tonometer in it, leaned against forehead of a patient (fig. 6 and 7).

Perpendicular position of the Tonometer's rod to the eye surface is an important condition. To reach perpendicularity of Tonometer setting it is necessary to combine Tonometer rod axis with the geometrical center of an eyeball (fig. 8)

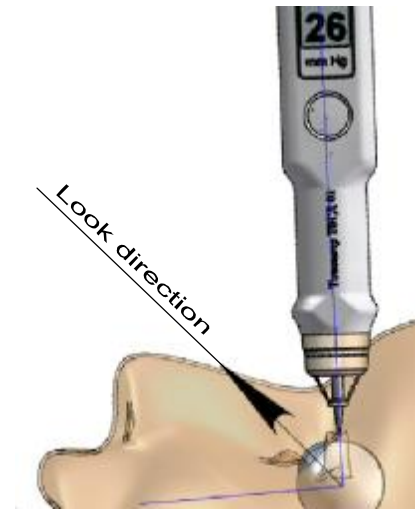

Fig. 8

Vertical setting of the device body is an important condition too. Especially during the period of training and at the initial stage of the device application. While taking IOP measurement it is necessary to know that the vertical deviation angle is to be not more than 15 degree. (fig. 9), keeping the condition of the device perpendicular setting. But with the experience it is possible to take IOP measurement accuracy with 30 degree angle vertical deviation without reducing of measurement accuracy.



Fig. 9

During the IOP measurement procedure the patient should be in lying or sitting position. The mandatory requirement here is position of the patient head, it should be as much as possible horizontal (see fig.10, 11).



Fig. 10



Fig. 11

IOP MEASUREMENT PROCEDURE

- Take the Tonometer out of the case.
- Turn the Tonometer in the position with its rod upward and remove the guard cap.
- Press "on/off" button momentarily to switch the Tonometer on. Be sure of the the device operationability according to the movements of the arrow on the display (fig. 5a).
- Check the Tonometer operationability by testing unit.
- Make both vibrator rod and guard ring disinfection wiping them by calico napkin moistened in solution.
- Hold the Tonometer body with an inscription «Tonometer TVGD-01» on it with fingers of your hand. Place the Tonometer with measuring rod downward, so that you can see the Tonometer display.
- Stand a bit aside, behind towards the patient. See fig.10.
- Focus and fix the patient eyesight with the help of test-object (take for example patent`s arm) so that the patent`s eyesight line is to be at the angle of 45°-50°. See fig.12.
- Rest the edge of the hand with the Tonometer in it on the patient`s forehead to make the measurement easy. The smoothness and accuracy of movements at measurement is reached owing to the hand support on the patient forehead (fig. 12).



Fig. 12

- With the finger of the other hand pull the upper eyelid toward the eyebrow without pressing the eyeball so that the border of the upper eyelid coincides with the eyeball limb (fig.13). Hold the eyelid in this position. Don't let the eyelid shift on the cornea at moment of taking IOP measurement! Don't press the eyeball.



Fig. 13

- The zone of the Tonometer rod exposure should fall on sclera area, corresponding to corona ciliaris in the meridian of 12 hours.
- **Smoothly** place the rod of the device on the eyelid 2-3mm. from the eyelid edge over the iris upper border (behind the ciliary wall). Recommended points are shown in the fig.14



Fig. 14

- Holding the Tonometer in vertical position smoothly lower the device body 2-3 mm. down. You'll feel the light vibration as a result of the activation of the dynamic impact. Carrying the IOP measurement out you should avoid the touch of the eyelid with guard ring. The last should be placed 2-3 mm. above the eyelid **If the body is moved down an inadmissible low, the disturbing sound signal is formed by the Tonometer, which is switched off automatically with the body raise to the working height**
- Smoothly move the Tonometer down, 1-2 seconds later you can hear a sound signal of measurement termination. Smoothly move the Tonometer up to complete the procedure of measurement. The moment of measurement completion is followed with sound signal and the appearance of IOP measurement value on the display.

- If there is no sound signal or it was generated with more than 3 second delay - the measurement is to be taken again.
- Press momentarily the “on/off” button to switch the Tonometer off.
- When the Tonometer is switched off, put the guard cap on turning the Tonometer with rod upward and put it back into case.



SAFETY MEASURES

- Be sure that the Tonometer body and rod have no mechanical damages. It is **FORBIDDEN** to use the defective Tonometer.
- Protect the Tonometer from shock or impact. For carrying put the tonometer into case lodgement with the cap put on its working part.
- Avoid the moisture penetration inside the Tonometer. If there is liquid inside the tonometer, before its use keep it at room temperature for at least 4 hours and then check its state of operability with a help of testing unit.
- Avoid temperature excess.
- Avoid drastic temperature differences that can affect the work of the Tonometer.

ATTENTION! Remember that the rod excessive impact on the eyeball may do harm to the patient.

MAINTENANCE

The order of Tonometer maintenance is given in the table below.

Maintenance procedure	Periodicity
1 Tonometer preventive maintenance inspection	Not less than once a day
2 Dusting and cleaning	When necessary
3 Working capacity test	Before each use
4 Inspection and replacing the power supply source	With the appearance of sign «  » on the display

When carrying preventive inspection pay special attention to the integrity of the Tonometer body and vibrator's rod mechanical damages.

The check of the Tonometer state of operation is to be carried out according to the procedure stated in the clause “The check of the Tonometer state of operation with the help of testing unit”.

ROUTINE MAINTENANCE

General instruction

Tonometer operating repair is carried out under the Agreement between medical institution and the manufacturing plant or its agency after the nature and degree of its malfunction technical survey by representatives of the manufacturer.

The signs of the Tonometer malfunction are:

- tonometer body and (or) vibrator's rod mechanical damages;
- tonometer readings with the use of testing unit differ from those stated in the clause "technical characteristics" more than ± 2 mm Hg;
- no indication of the Tonometer readings on the display with the occurrence of rod vibration sound;
- no indication of power supply voltage level signs.

Malfunctions during routine maintenance are eliminated by elements and details replacement or restoration, adjustment of a Tonometer in conformity with the data of the present manual.

After the termination of the repair the Tonometer is delivered to the user with the setting of warranty period which begins from the date of its delivery.

Security measures

There are no need in special security measures for the execution of repair works.

REPLACEMENT OF THE POWER SUPPLY ELEMENTS

Power supply elements replacement is to be done when the battery voltage is lower than 2V. Power supply voltage indicator at top left corner of the tonometer display shows the state of power supply elements. (see fig.15). The sign of the indicator when battery voltage is more than 3,2V is shown in the fig. 15a. The sign of indicator with the power voltage more than 2,8 V is shown in the fig.15b. With the battery voltage lower than 2V see fig 15c.

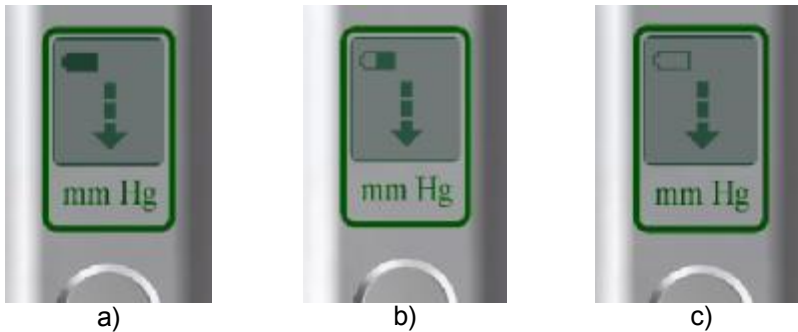

Fig. 15

Replacement of power supply elements is made when the Tonometer is switched - off.

To make power supply elements replacement it is necessary to remove the cover of battery compartment.(see fig.16a). Move the cover in the direction of arrow "OPEN", shown on the cover, to open it. The right arrangement of power supply ele-

ments is shown in fig. 16a и 16b. On the printed-circuit board under the power supply elements there is marking for batteries right position.

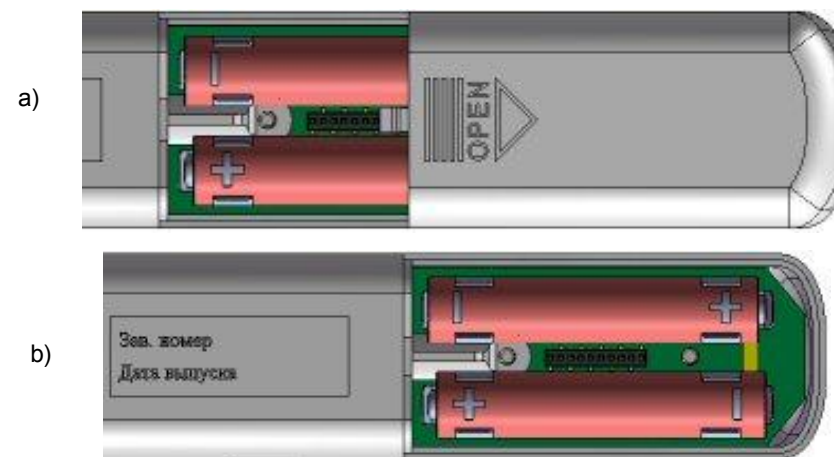

Fig. 16

It is convenient to take power supply elements out of battery holder by means of a plastic or wooden ruler, or a cover of battery compartment (see fig. 17).

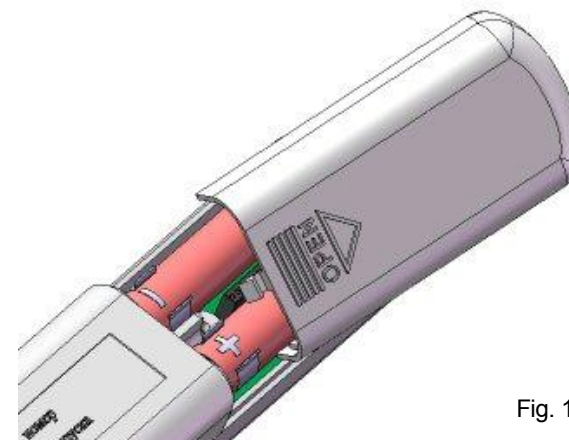

Fig. 17

For battery installation in holders it is necessary to place a battery atop of elastic clips of battery holders with the right battery connection polarity, and, then install a battery easy pressing battery down up to its lock in holders

ATTENTION: Right away after power supply elements installations it is necessary to switch the Tonometer on and off pressing momentarily "on/off" button. This way you can check the right order of power supply elements installation and the Tonometer is transformed in the mode of current microconsumption.

PROBABLE MALFUNCTIONS AND METHODS OF THEIR ELIMINATION

Malfunction	Malfunction probable cause	Method of malfunction elimination
The tonometer doesn't switch on	Power supply elements (batteries) are discharged.	Power supply elements are to be replaced.
	Batteries improper installation.	Power supply elements are to be switched on properly.
	No reliable connection of power supply batteries	Replacement of power supply batteries. Battery holders contacts clearing.
	Fault switch on button	Repair is carried out in the condition of after-sales service establishment.
	Fault tonometer.	Repair is carried out in the condition of after-sales service establishment.
Testing unit tonometer readings are differ from those stated in the passport more than two units	Improper check of tonometer state of operability with the help of testing unit	To gain working practices with testing unit "The check of tonometer state of operability with a help of testing unit"
	Tonometer is non adjusted.	Adjustment is carried out in the condition of after-sales service establishment.
	Failed tonometer.	Repair is carried out in the condition of after-sales service establishment.
After measurement (at raising tonometer up) vibrating action does not stop or stops with a delay (more than second).	Rod motion sensor is non adjusted.	Adjustment is carried out in the condition of after-sales service establishment.
Upon switching tonometer on there is both no indication on the display and generation of the alarm signal	Failed tonometer display.	Repair is carried out in the condition of after-sales service establishment.
Power supply battery are quickly discharged	Excess power consumption	Repair is carried out in the condition of after-sales service establishment.

CHECK OF TONOMETER OPERABILITY ON THE TESTING UNIT

The check of the tonometer operability on the testing unit is to be carried out not less than once a week, as well as after a long work break, device falling down and when you are not sure that the Tonometer is in good order.

The work with a testing unit is good to obtain practical skill in taking measurement by TVGD-01 tonometer.

The work on the testing unit is carried out under the following procedure:

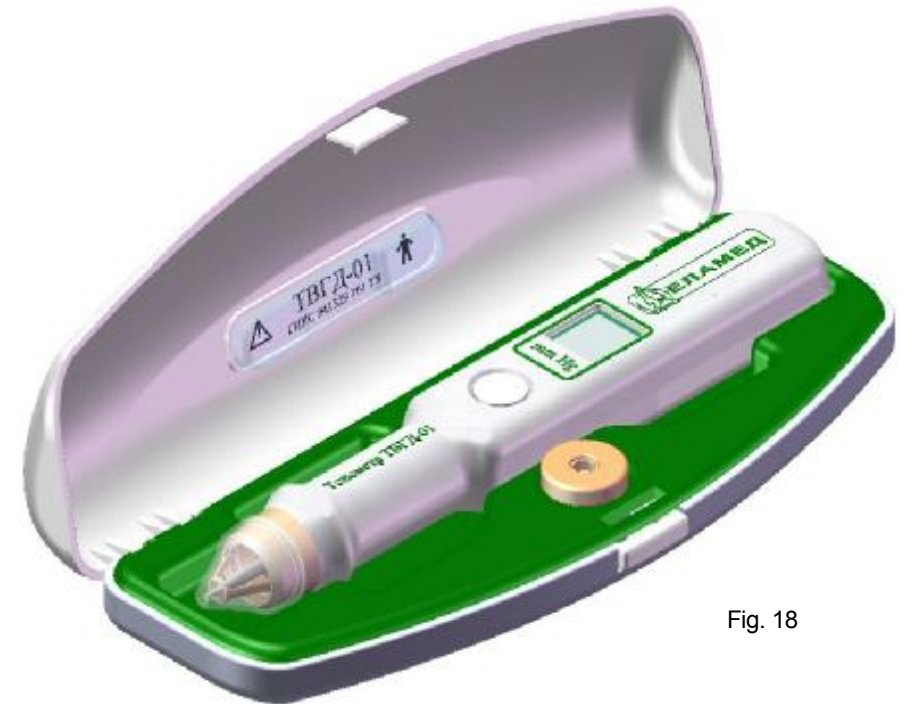

Fig. 18

1. Open the tonometer case (Fig. 18).
2. Take the Tonometer in your hand and arrange the open case with testing unit in it on the table (fig. 19).
3. Turn the Tonometer with rod upward and remove the guard cap.
4. Press the "ON/OFF" button momentarily to switch the Tonometer on.
5. Be sure of the Tonometer readiness to work according to arrow movements on the display (fig. 5a).
6. Hold Tonometer with the fingers of your hand by body cylindrical part with inscription "TVGD-01 Tonometer" on it. Hold Tonometer with the fingers of your hand by body cylindrical part with inscription "TVGD-01 Tonometer" on it.
7. Place Tonometer with measuring rod down and arrange the Tonometer body so that you can see the Tonometer display.

8. Place the Tonometer in vertical position with rod over the testing unit. The edge of the hand with the Tonometer in it should be leaned on the table surface Rest the edge of the hand with the Tonometer in it on the table surface (fig. 19).



Fig. 19

Attention! Tonometer is always to be in the vertical position when you take measurement

9. Easily move tonometer down (not taking the edge of the hand from the table surface) with the rod to the center of the testing unit (fig.20, 21) inserting the tonometer guard ring up to the stop into the ring slot of the testing unit. The lower plate of the tonometer guard ring should be closely coincide with slot ring plate. (fig. 22, 23).We can feel the activated measuring mode as slight hand vibration. Measuring mode is also followed with pressure indication on the Tonometer display

10. Holding a tonometer in this position, observe of the digital value of pressure displayed on the display of a tonometer. The mode of measurement will go on till raising tonometer up above the testing unit. Indication of digital value on the display should not differ from that stated in the clause "Technical characteristics" more than by two figures.

11. Smoothly raise the Tonometer up over the testing unit. Measuring mode is stopped and on the Tonometer display there is appeared the measured value.

12. Measuring mode can be repeated several times following items 9, 10 and 11 of this clause.

13. Press momentarily the "on/off" button to switch the Tonometer off.

14. Put the guard cap on turning tonometer with rod upward and put it back into the case.



Fig. 20



Fig.21



Fig. 22



Fig. 23

STORAGE AND TRANSPORTATION

Tonometer in manufacture`s package can be kept in the closed premise at the temperature between -50°C - + 40 °C , relative humidity up to 98% at + 25 °C.

Tonometer in manufacture`s package can be transported by any covered transportation facilities in microclimatic areas with both moderate and cold climate and ambient temperature between - 50 °C - +50 °C.

CERTIFICATE OF ACCEPTANCE

TVGD-01 Tonometer of intraocular pressure works serial No. _____, is manufactured and accepted in conformity with ГИКС.941329.101 ТУ and is recognized as ready for operation.

Date of output _____ Seal

(signature of the person responsible for acceptance)

TVGD-01 Tonometer of intraocular pressure is packed in accordance with the requirements of technical specifications.

Package date _____

The package is done by _____ Seal

MANUFACTURER`S WARRANTY

The manufacturer guarantees that the Tonometer quality is in compliance with the requirements of the Clause "Technical characteristics" of this operating manual.

Operation warranty period - 12 months from the date of sale.

The present operating manual is the document to claim on the Seller in case it duly documented. If in the operating manual there is no manufacturer`s original seal the claims are not accepted. Within the guarantee period manufacturer at his expense eliminates the defects or replaces the Tonometer provided its proper handling in accordance with the requirements of this operating manua. The replacement is done at the place of the Tomometer buying. The guaranty does not cover the Tonometer having mechanical damages.

For repair you should send the failed tonometer together with operating manual and the explanatory note at the address:

25 Yanina st., 391351, Yelatma, Kasimov district, Ryazan region, JSC «ЕПЗ».

Additional information you can get by tel. +7 (49131) 2-09-60, www.elamed.com

REPAIR

Brief records about the made repair.

TVGD-01 Tonometer of intraocular pressure works serial No. _____

The cause of repair _____

Information on repair made _____

TGVD-01 tonometer of intraocular pressure works serial No. _____ is accepted according to obligatory requirements of state standards and the working engineering specifications and recognized as ready to operation.

The executor of the repair guarantees the device conformity to requirements of the working engineering specifications provided observance requirements of the present document by the consumer.

Warranty period of the device operation - 12 months from the date of its acceptance by consumer.

Controller Technical control dep. _____
(Signature) (First, last name)

Seal

(Date, month, year)

FOR NOTES