

# STANLEY®

## HGL61 / 80 / 81 HYDRAULIC HORIZONTAL GRINDER



HGL61



HGL80 / 81

### USER MANUAL Safety, Operation and Maintenance



© 2015 Stanley Black & Decker, Inc.  
New Britain, CT 06053  
U.S.A.  
74809 10/2015 Ver. 1



# TABLE OF CONTENTS

SAFETY SYMBOLS .....	4
SAFETY PRECAUTIONS.....	5
TOOL STICKERS & TAGS .....	7
HOSE TYPES.....	8
HOSE RECOMMENDATIONS .....	9
FIGURE 1. TYPICAL HOSE CONNECTIONS .....	9
HTMA REQUIREMENTS.....	10
OPERATION.....	11
TOOL PROTECTION & CARE .....	12
TROUBLESHOOTING .....	13
SPECIFICATIONS.....	14
ACCESSORIES.....	15
HGL61 PARTS ILLUSTRATION .....	16
HGL61 PARTS LIST .....	17
HGL80 PARTS ILLUSTRATION .....	18
HGL80 PARTS LIST .....	19
MOTOR PARTS LIST AND ILLUSTRATION .....	20
BEARING NOSE PARTS LIST AND ILLUSTRATION .....	21

## IMPORTANT

To fill out a Product Warranty Validation form, and for information on your warranty, visit [Stanleyhydraulics.com](http://Stanleyhydraulics.com) and select the Company tab, Warranty.  
(NOTE: The warranty Validation record must be submitted to validate the warranty).

**SERVICING:** This manual contains safety, operation, and routine maintenance instructions. Stanley Hydraulic Tools recommends that servicing of hydraulic tools, other than routine maintenance, must be performed by an authorized and certified dealer. Please read the following warning.

## ⚠ WARNING

**SERIOUS INJURY OR DEATH COULD RESULT FROM THE IMPROPER REPAIR OR SERVICE OF THIS TOOL.**

**REPAIRS AND / OR SERVICE TO THIS TOOL MUST ONLY BE DONE BY AN AUTHORIZED AND CERTIFIED DEALER.**

For the nearest authorized and certified dealer, call Stanley Hydraulic Tools at the number listed on the back of this manual and ask for a Customer Service Representative.

# SAFETY SYMBOLS

Safety symbols and signal words, as shown below, are used to emphasize all operator, maintenance and repair actions which, if not strictly followed, could result in a life-threatening situation, bodily injury or damage to equipment.



This is the safety alert symbol. It is used to alert you to potential personal injury hazards. Obey all safety messages that follow this symbol to avoid possible injury or death.



This safety alert and signal word indicate an imminently hazardous situation which, if not avoided, will result in death or serious injury.



This safety alert and signal word indicate a potentially hazardous situation which, if not avoided, could result in death or serious injury.



This safety alert and signal word indicate a potentially hazardous situation which, if not avoided, could result in death or serious injury.



This signal word indicates a potentially hazardous situation which, if not avoided, may result in property damage.



This signal word indicates a situation which, if not avoided, will result in damage to the equipment.

This signal word indicates a situation which, if not avoided, may result in damage to the equipment.

Always observe safety symbols. They are included for your safety and for the protection of the tool.

## LOCAL SAFETY REGULATIONS

Enter any local safety regulations here. Keep these instructions in an area accessible to the operator and maintenance personnel.

---

---

---

---

---

---

---

---

---

---

---

---

---

---

---

---

---

# SAFETY PRECAUTIONS

Tool operators and maintenance personnel must always comply with the safety precautions given in this manual and on the stickers and tags attached to the tool and hose.

These safety precautions are given for your safety. Review them carefully before operating the tool and before performing general maintenance or repairs.

Supervising personnel should develop additional precautions relating to the specific work area and local safety regulations. If so, place the added precautions in the space provided in this manual.

The HGL Hydraulic Grinder will provide safe and dependable service if operated in accordance with the instructions given in this manual. Read and understand this manual and any stickers and tags attached to the grinder and hose before operation. Failure to do so could result in personal injury or equipment damage.



- Do not operate the tool with the wheel guard removed.
  - Do not operate a damaged, improperly adjusted, or incompletely assembled grinder.
  - Never wear loose clothing that can get entangled in the working parts of the tool.
  - Keep all parts of your body away from the rotating wheel. Long hair or loose clothing can become drawn into rotating components.
  - Keep the wheel off all surfaces when starting the grinder.
  - Do not use a wheel that is cracked, chipped or otherwise damaged. Always inspect wheels for possible damage before installation or use.
  - Always use wheels that conform to the specifications given in the OPERATION section of this manual.
  - Do not reverse grinding wheel rotation direction by changing fluid flow direction.
  - Do not move the tool until the wheel has stopped rotating. Release the trigger if the power supply has been interrupted.
  - To avoid personal injury or equipment damage, all tool repair, maintenance and service must only be performed by authorized and properly trained personnel.
  - If the material being ground creates an emission of dust and fumes, use personal protective devices.
  - Never cock, jam or wedge the grinding wheel during operation.
  - Never cause sparks in the vicinity of flammable materials.
  - Eye injury, and cutting or severing of body parts is possible if proper procedures are not followed.
  - **Warning:** Use of this tool on certain materials during demolition could generate dust potentially containing a variety of hazardous substances such as asbestos, silica or lead. Inhalation of dust containing these or other hazardous substances could result in serious injury, cancer or death. Protect yourself and those around you. Research and understand the materials you are cutting. Follow correct safety procedures and comply with all applicable national, state or provisional health and safety regulations relating to them, including, if appropriate arranging for the safe disposal of the materials by a qualified person.
- The operator must start in a work area without bystanders. Flying debris can cause serious injury.
  - Do not operate the tool unless thoroughly trained or under the supervision of an instructor. Establish a training program for all operators to ensure safe operation.
  - Always wear the appropriate safety equipment for the job such as goggles, ear protection, breathing mask, safety shoes and head protection at all times when operating the tool. Use gloves and aprons when necessary.
  - The operator must be familiar with all prohibited work areas such as excessive slopes and dangerous terrain conditions.
  - Do not inspect, clean or replace the grinding wheel while the hydraulic power source is connected. Do not inspect or clean the tool while the hydraulic power source is connected. Accidental engagement of the tool can cause serious injury.
  - Always connect hoses to the tool hose couplers before energizing the hydraulic power source. Be sure all hose connections are tight and are in good condition.
  - Do not operate the tool at oil temperatures above 140 °F/60 °C. Operation at higher temperatures can cause higher than normal temperatures at the tool which can result in operator discomfort.

# SAFETY PRECAUTIONS

## GRINDING WHEEL SAFETY

- Ensure that the grinding wheel is correctly mounted and tightened before use.
- Operate the grinder at “no load” for 30 seconds in a safe position and ensure there is no vibration or other defects detected. If considerable vibration or other defects are detected, stop operation of the tool immediately and determine the cause. Do not use the tool until the defect is corrected.
- If the grinder is dropped with an abrasive wheel installed, the abrasive wheel should be examined thoroughly before use.
- Only use abrasive wheels that comply with ANSI B7.1/ISO 525, 603.
- Check that the maximum rpm operating speed of the abrasive wheel is equal to or greater than the rated shaft speed of the grinder.
- Ensure that the grinding wheel dimensions are compatible with the grinder and that the grinding wheel fits the shaft.
- Ensure that the thread type and size of the grinding wheel exactly matches the thread type and size of the shaft.
- Do not operate this tool in a potentially explosive environment. Do not grind on vessels containing combustible substances.

# TOOL STICKERS & TAGS



74838  
COMPOSITE STICKER



74829  
Stanley Logo Decal

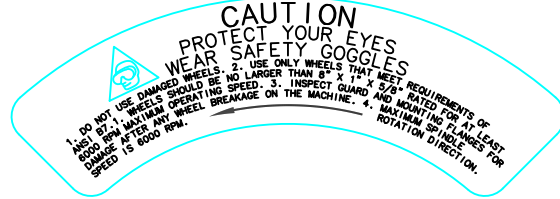

25414  
HGL80 / 81 CAUTION DECAL CCW ROTATION

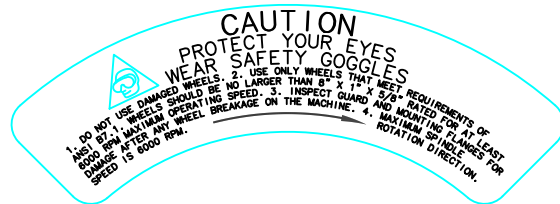

25556  
HGL 80 / 81 CAUTION DECAL CW ROTATION

## NOTE:

THE INFORMATION LISTED ON THE STICKERS SHOWN, MUST BE LEGIBLE AT ALL TIMES.

REPLACE DECALS IF THEY BECOME WORN OR DAMAGED. REPLACEMENTS ARE AVAILABLE FROM YOUR LOCAL STANLEY DISTRIBUTOR.

The safety tag (P/N 15875) at right is attached to the tool when shipped from the factory. Read and understand the safety instructions listed on this tag before removal. We suggest you retain this tag and attach it to the tool when not in use.

## DANGER

1. FAILURE TO USE HYDRAULIC HOSE LABELED AND CERTIFIED AS NON-CONDUCTIVE WHEN USING HYDRAULIC TOOLS ON OR NEAR ELECTRICAL LINES MAY RESULT IN DEATH OR SERIOUS INJURY.  
BEFORE USING HOSE LABELED AND CERTIFIED AS NON-CONDUCTIVE ON OR NEAR ELECTRICAL LINES BE SURE THE HOSE IS MAINTAINED AS NON-CONDUCTIVE. THE HOSE SHOULD BE REGULARLY TESTED FOR ELECTRIC CURRENT LEAKAGE IN ACCORDANCE WITH YOUR SAFETY DEPARTMENT INSTRUCTIONS.
2. A HYDRAULIC LEAK OR BURST MAY CAUSE OIL INJECTION INTO THE BODY OR CAUSE OTHER SEVERE PERSONAL INJURY.
  - A. **DO NOT** EXCEED SPECIFIED FLOW AND PRESSURE FOR THIS TOOL. EXCESS FLOW OR PRESSURE MAY CAUSE A LEAK OR BURST.
  - B. **DO NOT** EXCEED RATED WORKING PRESSURE OF HYDRAULIC HOSE USED WITH THIS TOOL. EXCESS PRESSURE MAY CAUSE A LEAK OR BURST.
  - C. CHECK TOOL HOSE COUPLERS AND CONNECTORS DAILY FOR LEAKS. **DO NOT** FEEL FOR LEAKS WITH YOUR HANDS. CONTACT WITH A LEAK MAY RESULT IN SEVERE PERSONAL INJURY.

## IMPORTANT

READ OPERATION MANUAL AND SAFETY INSTRUCTIONS FOR THIS TOOL BEFORE USING IT.

USE ONLY PARTS AND REPAIR PROCEDURES APPROVED BY STANLEY AND DESCRIBED IN THE OPERATION MANUAL.

TAG TO BE REMOVED ONLY BY TOOL OPERATOR.

SEE OTHER SIDE

## DANGER

- D. DO NOT LIFT OR CARRY TOOL BY THE HOSES. DO NOT ABUSE HOSE. DO NOT USE KINKED, TORN OR DAMAGED HOSE.
3. MAKE SURE HYDRAULIC HOSES ARE PROPERLY CONNECTED TO THE TOOL BEFORE PRESSURING SYSTEM. SYSTEM PRESSURE HOSE MUST ALWAYS BE CONNECTED TO TOOL "IN" PORT. SYSTEM RETURN HOSE MUST ALWAYS BE CONNECTED TO TOOL "OUT" PORT. REVERSING CONNECTIONS MAY CAUSE REVERSE TOOL OPERATION WHICH CAN RESULT IN SEVERE PERSONAL INJURY.
4. DO NOT CONNECT OPEN-CENTER TOOLS TO CLOSED-CENTER HYDRAULIC SYSTEMS. THIS MAY RESULT IN LOSS OF OTHER HYDRAULIC FUNCTIONS POWERED BY THE SAME SYSTEM AND/OR SEVERE PERSONAL INJURY.
5. BYSTANDERS MAY BE INJURED IN YOUR WORK AREA. KEEP BYSTANDERS CLEAR OF YOUR WORK AREA.
6. WEAR HEARING, EYE, FOOT, HAND AND HEAD PROTECTION.
7. TO AVOID PERSONAL INJURY OR EQUIPMENT DAMAGE, ALL TOOL REPAIR MAINTENANCE AND SERVICE MUST ONLY BE PERFORMED BY AUTHORIZED AND PROPERLY TRAINED PERSONNEL.

## IMPORTANT

READ OPERATION MANUAL AND SAFETY INSTRUCTIONS FOR THIS TOOL BEFORE USING IT.

USE ONLY PARTS AND REPAIR PROCEDURES APPROVED BY STANLEY AND DESCRIBED IN THE OPERATION MANUAL.

TAG TO BE REMOVED ONLY BY TOOL OPERATOR.

SEE OTHER SIDE

SAFETY TAG P/N 15875 (Shown smaller than actual size)

# HOSE TYPES

The rated working pressure of the hydraulic hose must be equal to or higher than the relief valve setting on the hydraulic system. There are three types of hydraulic hose that meet this requirement and are authorized for use with Stanley Hydraulic Tools. They are:

**Certified non-conductive** — constructed of thermoplastic or synthetic rubber inner tube, synthetic fiber braid reinforcement, and weather resistant thermoplastic or synthetic rubber cover. *Hose labeled **certified non-conductive** is the only hose authorized for use near electrical conductors.*

**Wire-braided** (conductive) — constructed of synthetic rubber inner tube, single or double wire braid reinforcement, and weather resistant synthetic rubber cover. *This hose is **conductive** and must never be used near electrical conductors.*

**Fabric-braided** (not certified or labeled non-conductive) — constructed of thermoplastic or synthetic rubber inner tube, synthetic fiber braid reinforcement, and weather resistant thermoplastic or synthetic rubber cover. *This hose is **not certified non-conductive** and must never be used near electrical conductors.*

## HOSE SAFETY TAGS

To help ensure your safety, the following DANGER tags are attached to all hose purchased from Stanley Hydraulic Tools. **DO NOT REMOVE THESE TAGS.**

If the information on a tag is illegible because of wear or damage, replace the tag immediately. A new tag may be obtained from your Stanley Distributor.

### THE TAG SHOWN BELOW IS ATTACHED TO “CERTIFIED NON-CONDUCTIVE” HOSE

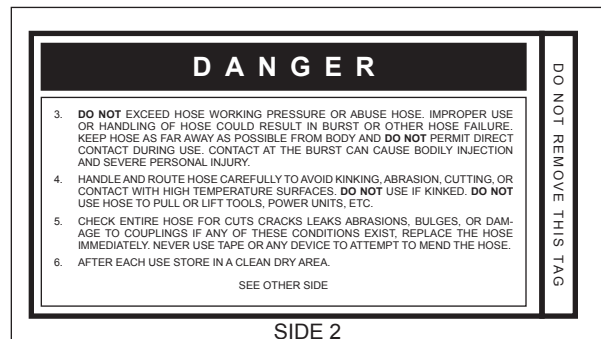
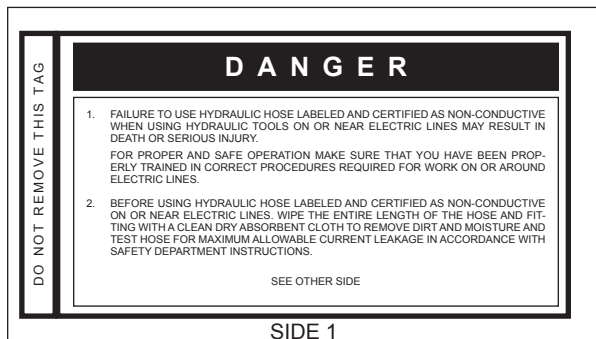

(Shown smaller than actual size)

### THE TAG SHOWN BELOW IS ATTACHED TO “CONDUCTIVE” HOSE.

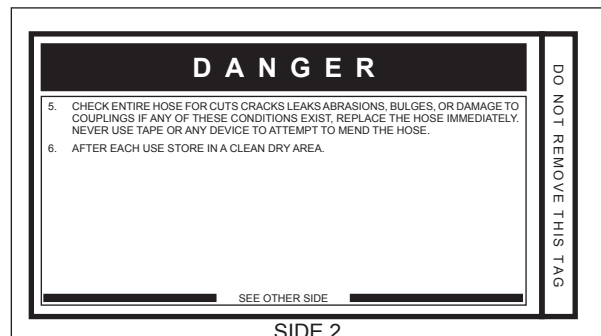
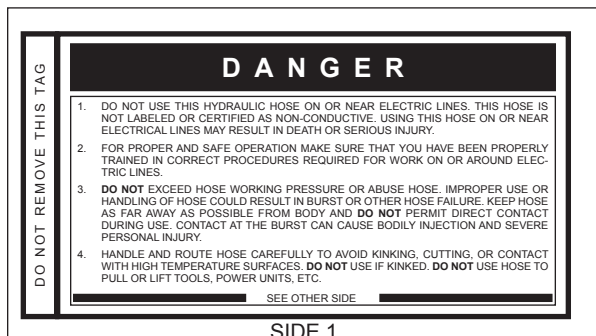

(Shown smaller than actual size)



# HOSE RECOMMENDATIONS

## Tool to Hydraulic Circuit Hose Recommendations

The chart to the right shows recommended minimum hose diameters for various hose lengths based on gallons per minute (gpm)/liters per minute (lpm). These recommendations are intended to keep return line pressure (back pressure) to a minimum acceptable level to ensure maximum tool performance.

This chart is intended to be used for hydraulic tool applications only based on Stanley Hydraulic Tools tool operating requirements and should not be used for any other applications.

All hydraulic hose must have at least a rated minimum working pressure equal to the maximum hydraulic system relief valve setting.

**All hydraulic hose must meet or exceed specifications as set forth by SAE J517.**

Oil Flow		Hose Lengths		Inside Diameter		USE (Press/Return)	Min. Working Pressure	
GPM	LPM	FEET	METERS	INCH	MM		PSI	BAR
<b>Certified Non-Conductive Hose - Fiber Braid - for Utility Bucket Trucks</b>								
4-9	15-34	up to 10	up to 3	3/8	10	Both	2250	155
<b>Conductive Hose - Wire Braid or Fiber Braid -DO NOT USE NEAR ELECTRICAL CONDUCTORS</b>								
4-6	15-23	up to 25	up to 7.5	3/8	10	Both	2500	175
4-6	15-23	26-100	7.5-30	1/2	13	Both	2500	175
5-10.5	19-40	up to 50	up to 15	1/2	13	Both	2500	175
5-10.5	19-40	51-100	15-30	5/8	16	Both	2500	175
5-10.5	19-40	100-300	30-90	5/8	16	Pressure	2500	175
10-13	38-49	up to 50	up to 15	3/4	19	Return	2500	175
10-13	38-49	51-100	15-30	5/8	16	Both	2500	175
10-13	38-49	100-200	30-60	3/4	19	Pressure	2500	175
13-16	49-60	up to 25	up to 8	5/8	16	Return	2500	175
13-16	49-60	26-100	8-30	3/4	19	Pressure	2500	175
				1	25.4	Return	2500	175
				5/8	16	Pressure	2500	175
				3/4	19	Return	2500	175
				3/4	19	Pressure	2500	175
				1	25.4	Return	2500	175

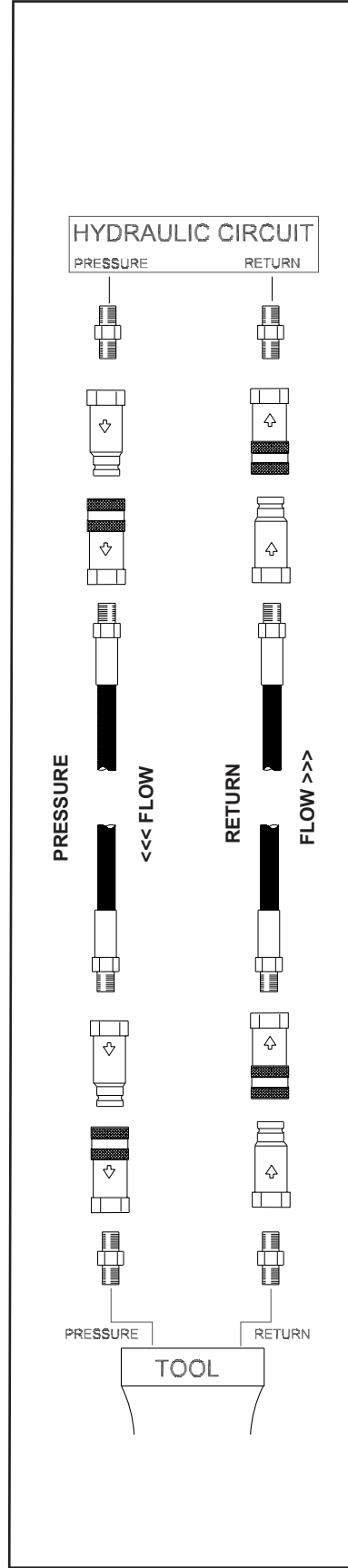

Figure 1. Typical Hose Connections

# HTMA / EHTMA REQUIREMENTS

## HTMA / EHTMA REQUIREMENTS

### HTMA





#### HYDRAULIC SYSTEM REQUIREMENTS

### TOOL TYPE

	TYPE I	TYPE II	TYPE RR	TYPE III
Flow Range	4-6 gpm (15-23 lpm)	7-9 gpm (26-34 lpm)	9-10.5 gpm (34-40 lpm)	11-13 gpm (42-49 lpm)
Nominal Operating Pressure (at the power supply outlet)	1500 psi (103 bar)	1500 psi (103 bar)	1500 psi (103 bar)	1500 psi (103 bar)
System relief valve setting (at the power supply outlet)	2100-2250 psi (145-155 bar)	2100-2250 psi (145-155 bar)	2200-2300 psi (152-159 bar)	2100-2250 psi (145-155 bar)
Maximum back pressure (at tool end of the return hose)	250 psi (17 bar)	250 psi (17 bar)	250 psi (17 bar)	250 psi (17 bar)
Measured at a max. fluid viscosity of: (at min. operating temperature)	400 ssu* (82 centistokes)	400 ssu* (82 centistokes)	400 ssu* (82 centistokes)	400 ssu* (82 centistokes)
Temperature: Sufficient heat rejection capacity to limit max. fluid temperature to: (at max. expected ambient temperature)	140° F (60° C)	140° F (60° C)	140° F (60° C)	140° F (60° C)
Min. cooling capacity at a temperature difference of between ambient and fluid temps <b>NOTE:</b> Do not operate the tool at oil temperatures above 140° F (60° C). Operation at higher temperatures can cause operator discomfort at the tool.	3 hp (2.24 kW) 40° F (22° C)	5 hp (3.73 kW) 40° F (22° C)	6 hp (5.22 kW) 40° F (22° C)	7 hp (4.47 kW) 40° F (22° C)
Filter Min. full-flow filtration Sized for flow of at least: (For cold temp. startup and max. dirt-holding capacity)	25 microns 30 gpm (114 lpm)	25 microns 30 gpm (114 lpm)	25 microns 30 gpm (114 lpm)	25 microns 30 gpm (114 lpm)
Hydraulic fluid Petroleum based (premium grade, anti-wear, non-conductive) Viscosity (at min. and max. operating temps)	100-400 ssu*	100-400 ssu* (20-82 centistokes)	100-400 ssu*	100-400 ssu*
<b>NOTE:</b> When choosing hydraulic fluid, the expected oil temperature extremes that will be experienced in service determine the most suitable temperature viscosity characteristics. Hydraulic fluids with a viscosity index over 140 will meet the requirements over a wide range of operating temperatures.				
*SSU = Saybolt Seconds Universal				

### EHTMA HYDRAULIC SYSTEM REQUIREMENTS

### CLASSIFICATION

					
Flow Range	3.5-4.3 gpm (13.5-16.5 lpm)	4.7-5.8 gpm (18-22 lpm)	7.1-8.7 gpm (27-33 lpm)	9.5-11.6 gpm (36-44 lpm)	11.8-14.5 gpm (45-55 lpm)
Nominal Operating Pressure (at the power supply outlet)	1870 psi (129 bar)	1500 psi (103 bar)	1500 psi (103 bar)	1500 psi (103 bar)	1500 psi (103 bar)
System relief valve setting (at the power supply outlet)	2495 psi (172 bar)	2000 psi (138 bar)	2000 psi (138 bar)	2000 psi (138 bar)	2000 psi (138 bar)

**NOTE:** These are general hydraulic system requirements. See tool specification page for tool specific requirements

# OPERATION

## PRE-OPERATION PROCEDURES

### CHECK HYDRAULIC POWER SOURCE

1. Using a calibrated flowmeter and pressure gauge, check that the hydraulic power source develops a flow of 7–10 gpm/26–38 lpm at 1500–2000 psi/105–140 bar.
2. Make certain the hydraulic power source is equipped with a relief valve set to open at 2100–2250 psi/145–155 bar minimum.
3. Check that the hydraulic circuit matches the tool for open-center (OC) or closed-center (CC) operation.

### CHECK TOOL

1. Make sure all tool accessories are correctly installed. Failure to install tool accessories properly can result in damage to the tool or personal injury.
2. There should be no signs of leaks.
3. The tool should be clean, with all fittings and fasteners tight.

### CHECK TRIGGER MECHANISM

1. Check that the trigger operates smoothly and is free to travel between the **ON** and **OFF** positions.

### CHECK GUARD ASSEMBLY

1. Inspect the wheel guard assembly (if equipped) for cracks and other structural damage. Do not operate if damaged.

## INSTALLING AND REMOVING GRINDING WHEELS

**READ AND BECOME FAMILIAR WITH THE SECTIONS IN THIS MANUAL ON SAFETY PRECAUTIONS, TOOL STICKERS AND TAGS, HYDRAULIC HOSE REQUIREMENTS, HYDRAULIC REQUIREMENTS, AND PRE-OPERATION PROCEDURES BEFORE USING THIS PRODUCT.**

### NOTE:

**On HGL80/81 use 8 inch by 1 inch thick (Type 1) grinding wheels with a 5/8 arbor hole. Only use grinding wheels which comply with ANSI B7.1/ISO 525, 603.**

1. Loosen 3 capscrews (item 1, page 18) and remove the guard front plate (item 20, page 18) and set aside.
2. Depress the push lock (item 12, page 21) to lock the spindle. Unscrew the jam nut (item 4, page 18). Remove the outside flange (item 8, page 18).

3. Make sure blotters or labels remain on the grinding wheel. Install the grinding wheel onto the spindle (item 15, page 21) and reinstall the outside flange and jam nut.
4. Depress the push lock and tighten the jam nut. Only tighten sufficiently to prevent slippage of the wheel between the flanges.
5. Reinstall the guard front plate and capscrews.

### CONNECT HOSES

1. Wipe all hose couplers with a clean lint-free cloth before making connections.
2. Connect the hoses from the hydraulic power source to the hose couplers on the grinder. It is a good practice to connect the return hose first and disconnect it last to minimize or avoid trapped pressure within the grinder motor.
3. Observe flow indicators stamped on hose couplers to be sure that oil will flow in the proper direction. The female coupler is the inlet coupler.

### NOTE:

**The pressure increase in uncoupled hoses left in the sun may result in making them difficult to connect. When possible, connect the free ends of operating hoses together.**

## OPERATING PROCEDURES

1. Observe all safety precautions.
2. Always start the grinder with the grinding wheel or cone away from the work surface and have both hands on the grinder at all times.
3. Move the hydraulic circuit control valve to the **ON** position.
4. Squeeze the trigger momentarily. If the grinder does not operate, the hoses might be reversed. Verify correct connection of the hoses before continuing.
5. Start the grinder and move the grinding wheel or cone to the work surface.
6. Grind a small amount of material at a time.

## COLD WEATHER OPERATION

If the grinder is to be used during cold weather, preheat the hydraulic fluid at low engine speed. When using the normally recommended fluids, fluid temperature should be at or above 50 °F/10 °C (400 ssu/82 centistokes) before use.

# TOOL PROTECTION & CARE

## NOTICE

In addition to the Safety Precautions found in this manual, observe the following for equipment protection and care.

- Make sure all couplers are wiped clean before connection.
- The hydraulic circuit control valve must be in the **OFF** position when coupling or uncoupling hydraulic tools. Failure to do so may result in damage to the quick couplers and cause overheating of the hydraulic system.
- Always store the tool in a clean dry space, safe from damage or pilferage.
- Make sure the circuit **PRESSURE** hose (with male quick disconnect) is connected to the **IN** port. The circuit **RETURN** hose (with female quick disconnect) is connected to the opposite port. Do not reverse circuit flow. This can cause damage to internal seals.
- Always replace hoses, couplings and other parts with replacement parts recommended by Stanley Hydraulic Tools. Supply hoses must have a minimum working pressure rating of 2500 psi/172 bar.
- Do not exceed the rated flow and pressure. See Specifications in this manual for correct flow rate and pressure rating. Rapid failure of the internal seals may result.
- Always keep critical tool markings, such as warning stickers and tags legible.
- Tool repair should be performed by experienced personnel only.
- Make certain that the recommended relief valves are installed in the pressure side of the system.
- Do not use the tool for applications for which it was not intended.

# TROUBLESHOOTING

If symptoms of poor performance develop, the following chart can be used as a guide to correct the problem.

When diagnosing faults in operation of the grinder, always check that the hydraulic power source is supplying the correct hydraulic flow and pressure to the grinder as listed in the table. Use a flowmeter known to be accurate. Check the flow with the hydraulic oil temperature at least 80 °F/27 °C.

Problem	Cause	Solution
Grinder does not run.	Hydraulic power source not functioning.	Check power source for proper flow and pressure (7–10 gpm/26–38 lpm @ 1500–2000 psi/105–140 bar.
	Couplers or hoses blocked.	Locate and remove restriction.
	Hydraulic motor failure.	Inspect and repair.
	Hydraulic lines not connected.	Connect lines.
	Shaft lock is engaged	Check that the shaft lock is not engaged.
Grinder operates too slow.	Hydraulic motor speed too slow.	Check power unit for proper flow (7–10 gpm/26–38 lpm).
	High back-pressure.	Check hydraulic system for excessive back-pressure (over 250 psi/17 bar).
	Couplers or hoses blocked.	Locate and remove restriction.
	Oil too hot (above 140 °F/60 °C) or too cold (below 60 °F/16 °C).	Check hydraulic power source for proper oil temperature. Bypass cooler to warm oil or provide cooler to maintain proper temperature.
	Relief valve set too low.	Adjust relief valve to 2100–2250psi/145–155 bar.
	Hydraulic motor worn.	Inspect, repair or replace.
	Flow control malfunctioning.	Have flow control serviced at an authorized Stanley service center.
Grinder operates too fast.	Flow control malfunctioning.	Have flow control and valve body serviced at an authorized Stanley service center.
Excessive vibration	Grinding wheel or cone missing wheel segments.	Check grinding wheel or cone for any large missing segments of the wheel that could cause an out of balance condition.
	Bent motor shaft.	Check motor shaft for any bent condition, replace if necessary.

# SPECIFICATIONS

Wheel Capacity	
HGL61 CCW Rotation (5500 rpm).....	Bullnose
HGL80 CCW or CW Rotation, 8" Wheel (5500 rpm).....	8 in. dia. × 1 in. thk × 5/8 arbor (type 1)
Pressure Range.....	2000–2500 psi/138–172 bar
Maximum Back Pressure.....	250 psi/17 bar
Flow Range .....	7–10 gpm/26–38 lpm
Optimum Flow .....	10 gpm/38 lpm
Porting .....	–8 SAE O-ring
Couplers .....	HTMA/EHTMA Flush Face Type Male & Female
Hose Whips .....	Yes
Weight HGL61 / 61-N (with hose whips & couplers and without bullnose stone).....	9.6 lbs / 4.3 kg
Overall Length HGL61 / 61-N.....	19 in. / 48.2 cm
Overall Width HGL61 / 61-N.....	10 in. / 25.4 cm
Weight HGL80 / 81 (with hose whips & couplers and without grinding wheel).....	13.6 lbs / 6.1 kg
Overall Length HGL80 / 80-N / 80-L / 80-LN .....	23.35 in. / 59.3 cm
Overall Length HGL81 / 81-N / 81-L / 81-LN .....	19 in. / 48.2 cm
Overall Width HGL80 / 80-N / 80-L / 80-LN.....	12 in. / 30.4 cm
Overall Width HGL81 / 81-N / 81-L / 81-LN.....	12 in. / 30.4 cm
RPM.....	5500 Max
Maximum Fluid Temperature .....	140 °F/60 °C

## ACCESSORIES

Grinding Wheel – Norton Norzon IV (8 inch dia. × 1 inch wide × 5/8 arbor) (HGL80/81).....28598



Grinding Wheel Cone – Bullnose (HGL61).....30872



Threads on wheel  
cone are 5/8-11

# HGL61 PARTS ILLUSTRATION

NOTE: BOTH THE HGL61 AND HGL61N ARE CCW ROTATION TOOLS. THE ONLY DIFFERENCE BETWEEN THE TWO MODELS ARE THE TYPE OF COUPLERS.

NOTE: ITEM # 8 INCLUDES BEARING NOSE AND GRINDER MOTOR, SEE PAGES 20 & 21 FOR PARTS.

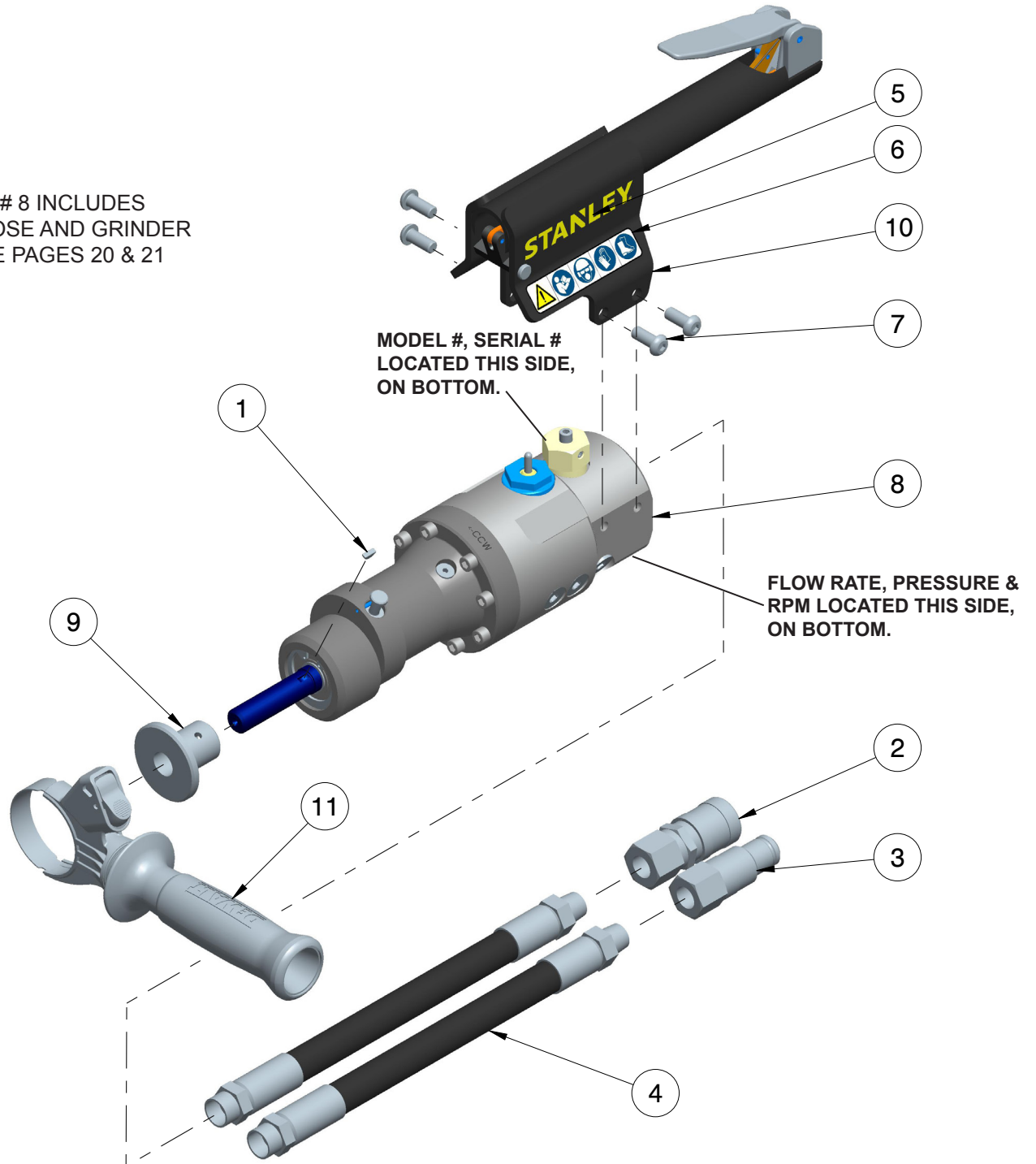



# HGL61 PARTS LIST

ITEM #	P/N	QTY	DESCRIPTION
1	02447	1	KEY 1/8"x3/8" WOODRUFF
2	03972	1	COUPLER,3/8FEM. 3/8NPT, MODEL HGL61
	47436	1	COUPLER,3/8FEM. 3/8NPT AERO-QUIP, MODEL HGL61N
3	03973	1	COUPLER,3/8MALE 3/8NPT, MODEL HGL61
	47437	1	COUPLER,3/8MALE 3/8NPT AERO-QUIP, MODEL HGL61N
4	58630	2	HOSE ASSY, PARKER MODEL HGL61
	66728	2	HOSE ASSY, AEROQUIP MODEL HGL61N
5	74829	2	DECAL - STANLEY LOGO
6	74838	1	COMPOSITE STICKER
7	207845	4	CAPSCREW 5/16UNCx3/4
8			GRINDER MOTOR WITH ATTACHED BEARING NOSE, SEE PAGES 20 & 21 FOR PARTS.
9	211148	1	DRIVE FLANGE
10	74888	1	SHORT HANDLE ASSEMBLY (INCLUDES DECALS)
11	211577	1	FRONT AUX HANDLE ASM

**NOTE: BOTH THE HGL61 AND HGL61N ARE CCW ROTATION TOOLS. THE ONLY DIFFERENCE BETWEEN THE TWO MODELS ARE THE TYPE OF COUPLERS.**

## SEAL KIT P/N - 74868

COUPLER SET P/N-03971 (ONE EACH OF ITEM # 2 & 3)  
USED ON MODEL HGL61

COUPLER SET P/N-47438 (ONE EACH OF ITEM # 2 & 3)  
USED ON MODEL HGL61N

# HGL80 / 81 PARTS ILLUSTRATION

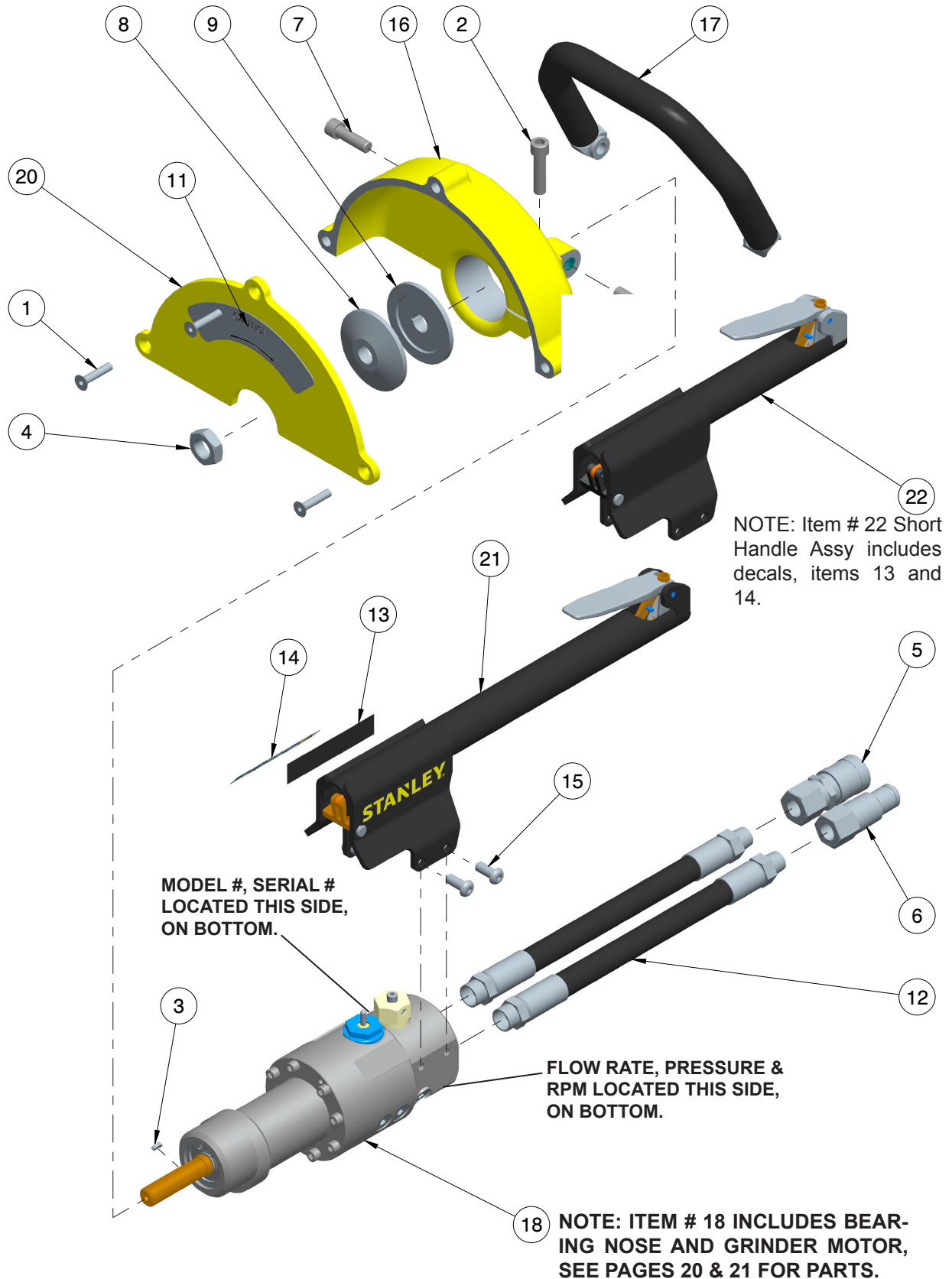

# HGL80 / 81 PARTS LIST

ITEM #	P/N	QTY	DESCRIPTION
1	00787	3	CAPSCREW 1/4-20 X 1-1/4
2	01458	1	HSHCS 3/8-16 X 1-1/2
3	02447	1	KEY 1/8"x3/8" #213 WOODRUFF
4	03012	1	HEAVY HEX JAM NUT 5/8-11UNC LEFT HAND, MODELS - HGL80, HGL80N, HGL81, HGL81N.
	01714	1	HEAVY HEX JAM NUT 5/8-11UNC RIGHT HAND, MODELS - HGL80L, HGL80LN, HGL81L, HGL81LN
5	03972	1	COUPLER,3/8FEM. 3/8NPT FL.FACE SET 03971, MODELS HGL80, HGL80L, HGL81, HGL81L
	47436	1	COUPLER,3/8FEM. 3/8NPT FL.FACE SET 47438, MODELS - HGL80LN, HGL80N, HGL81LN, HGL81N
6	03973	1	COUPLER,3/8MALE 3/8NPT FL.FACE SET 03971 MODELS HGL80, HGL80L, HGL81, HGL81L
	47437	1	COUPLER,3/8MALE 3/8NPT FL.FACE SET 47438, MODELS - HGL80LN, HGL80N, HGL81LN, HGL81N
7	10793	2	HSHCS 3/8-16 X 1-1/4
8	25354	1	OUTSIDE FLANGE
9	25355	1	DRIVE FLANGE
11	25414	1	CAUTION STICKER <b>CCW</b> ROTATION
	25556	1	CAUTION STICKER <b>CW</b> ROTATION
12	58630	2	HOSE ASSY PARKER, MODELS HGL80, HGL80L, HGL81, HGL81L
	66728	2	HOSE ASSY AEROQUIP, MODELS - HGL80LN, HGL80N, HGL81LN, HGL81N
13	74829	2	DECAL - STANLEY LOGO 3.75"
14	74838	1	COMPOSITE STICKER
15	207845	4	CAPSCREW 5/16UNCx3/4 HSBH
16	210882	1	INNER GUARD ASSEMBLY
17	211077	1	AUX HANDLE WELDMENT
18			GRINDER MOTOR WITH ATTACHED BEARING NOSE, SEE PAGES 20 & 21 FOR PARTS
20	211154	1	GUARD FRONT PLATE
21	74887	1	STANDARD HANDLE ASSEMBLY (INCLUDES DECALS)
22	74888	1	SHORT HANDLE ASSEMBLY (INCLUDES DECALS)

**NOTE: THE FOLLOWING MODELS ARE CW ROTATION:**  
HGL80  
HGL80-N  
HGL81  
HGL81-N

**NOTE: THE FOLLOWING MODELS ARE CCW ROTATION:**  
HGL80-L  
HGL80-LN  
HGL81-L  
HGL81-LN

**SEAL KIT P/N - 74868**

# MOTOR PARTS LIST & ILLUSTRATION

ITEM #	P/N	QTY	DESCRIPTION
1	00026	1	O-RING
2	00289	2	DOWEL PIN 3/16 X 3/4 LG.
3	01608	1	STEEL BALL 3/16
5	03227	2	DOWEL PIN
6	06316	2	BUSHING, GARLOCK 07DU08
7	06891	1	O-RING
8	08104	6	HOLLOW HEX PLUG - 6 SAE
9	22064	1	ROD WIPER
10	25635	1	FLOW REGLTR.CRTRDG.
11	25666	2	DRIVE GEAR

ITEM #	P/N	QTY	DESCRIPTION
12	73021	1	SAE ORB PLUG MODIFIED
13	74866	1	MOTOR VALVE, GRINDER ASSEMBLY, INCLUDES ITEM # 6
14	207835	1	CHECK VALVE ASM
15	207839	1	TRIGGER CAP
16	74865	1	SPOOL ASSEMBLY OC
18	211510	1	SPRING COMPRESSION
19	211511	1	SPRING COMPRESSION
20	211512	1	ORFICE PLUG
21	211519	1	SPRING SEAT
22	350016	1	HOLLOW HEX PLUG -2 SAE

**ALL HGL MODELS  
USE THE SAME  
MOTOR PARTS**

**SEAL KIT P/N-74868**

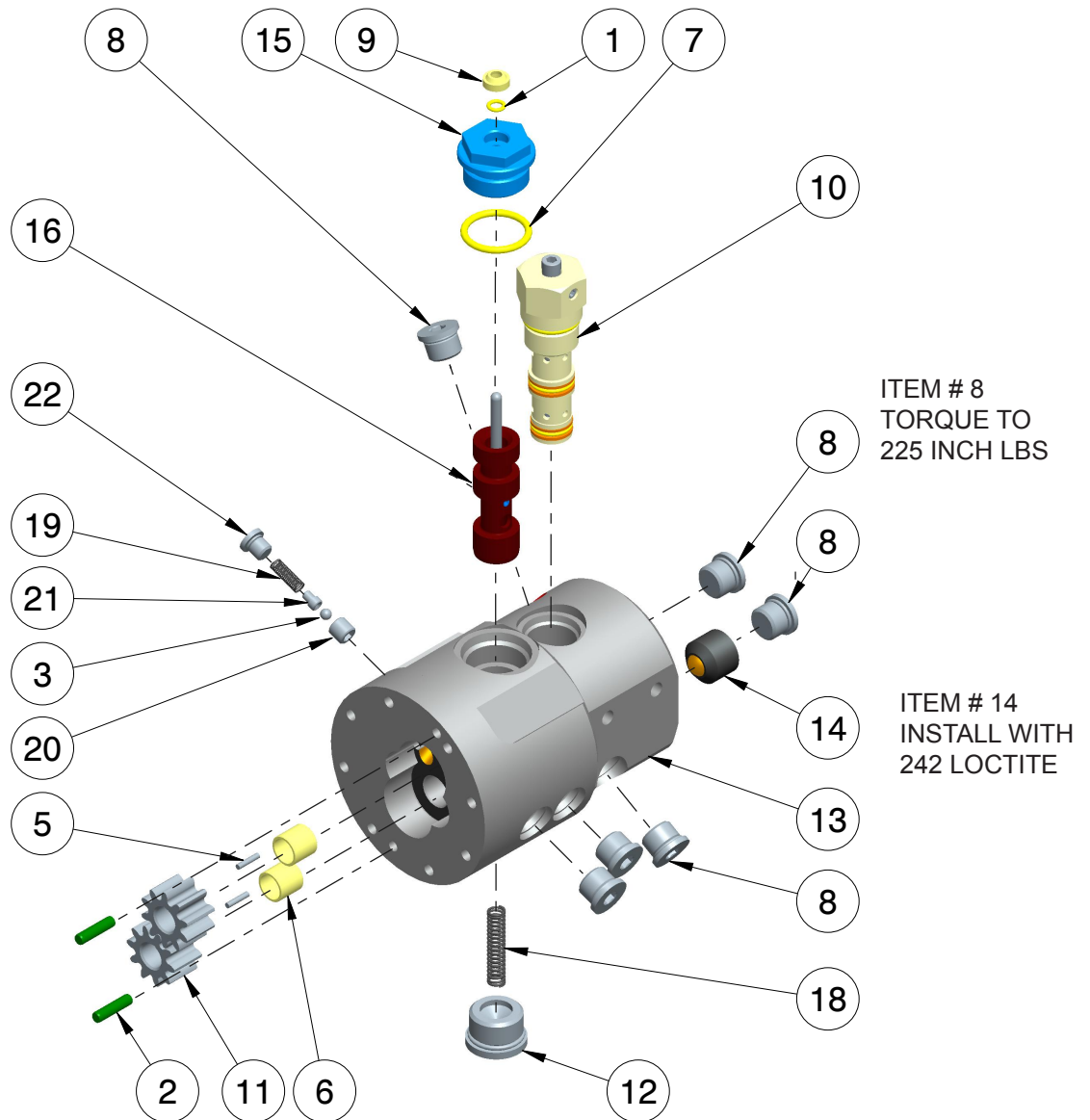

# BEARING NOSE PARTS LIST & ILLUSTRATION

ITEM #	P/N	QTY	DESCRIPTION
1	00106	1	O-RING
2	00171	1	O-RING
3	00214	1	QUAD RING
4	00708	1	RETAINING RING
5	01205	1	O-RING
6	01521	8	HSHCS 1/4-20 X 1.000
7	04856	1	RETAINING RING
8	06316	2	BUSHING, GARLOCK
9	16638	1	RETAINING RING
10	73308	1	IDLER SHAFT KEYED
11	207823	2	BEARING
12	207828	1	SHAFT LOCK
13	207843	1	SPRING

ITEM #	P/N	QTY	DESCRIPTION
14	74867	1	BEARING HOUSING, CW ROTATION, USED WITH P/N- 211071 SEE ITEM 15 INCLUDES ITEM # 8.
	74869		BEARING HOUSING, CCW ROTATION, USED WITH P/N- 210880 SEE ITEM 15 INCLUDES ITEM # 8.
15	211071	1	MOTOR SHAFT, GRINDER CW ROTATION
	210880		MOTOR SHAFT, GRINDER CCW ROTATION
16	211072	1	SEAL CARRIER
17	350016	1	HOLLOW HEX PLUG -2 SAE
18	372043	1	ROLL PIN

## SEAL KIT P/N-74868

**NOTE: THE FOLLOWING MODELS ARE CW ROTATION:**  
HGL80  
HGL80-N  
HGL81  
HGL81-N

**NOTE: THE FOLLOWING MODELS ARE CCW ROTATION:**  
HGL61  
HGL61N  
HGL80-L  
HGL80-LN  
HGL81-L  
HGL81-LN

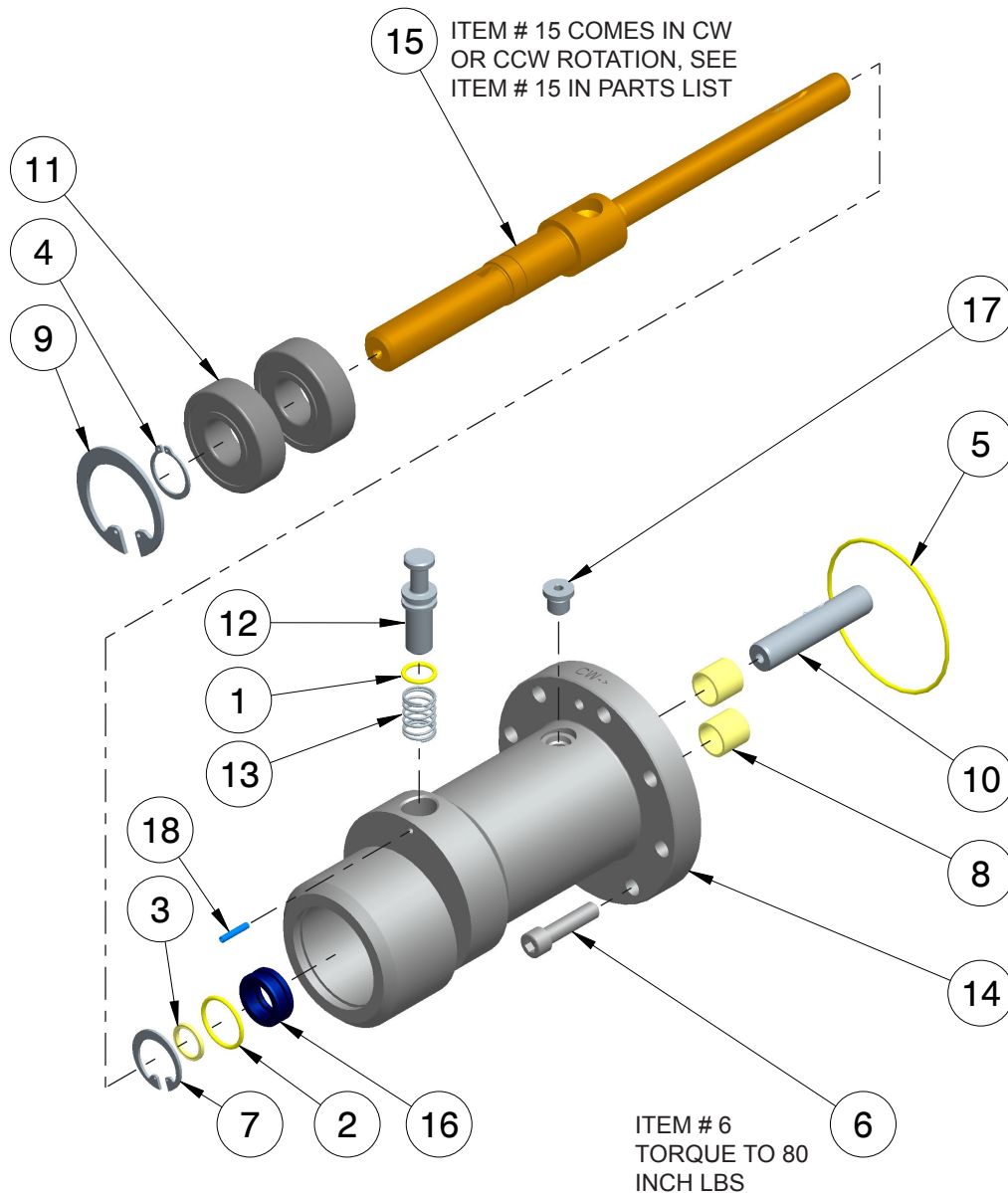

# **STANLEY®**

Stanley Hydraulic Tools  
3810 SE Naef Road  
Milwaukie, Oregon 97267-5698 USA  
(503) 659-5660 / Fax (503) 652-1780  
[www.stanleyhydraulics.com](http://www.stanleyhydraulics.com)