

## INSTALLATION AND USER INSTRUCTIONS FOR THE FREE STANDING RANGE FOR THE HOME

THIS APPLIANCE WAS DESIGNED FOR EASE OF INSTALLATION AND OPERATION. HOWEVER, WE RECOMMEND THAT YOU READ ALL SECTIONS OF THIS MANUAL BEFORE YOU BEGIN INSTALLATION. INSTALLATION IS TO BE PERFORMED BY AN APPROVED GAS INSTALLATION OR GAS SERVICE TECHNICIAN. **IN THE COMMONWEALTH OF MASSACHUSETTS A LICENSED PLUMBER OR GAS FITTER** CAPABLE OF REVIEWING AND PERFORMING THE MANUFACTURER'S INSTALLATION CHECKLIST SHOULD INSTALL THIS APPLIANCE. THE INSTALLATION CHECKLIST IS INCLUDED AT THE REAR OF THIS BOOKLET.

DO NOT REMOVE PERMANENTLY AFFIXED LABELS, WARNINGS OR DATA PLATES FROM YOUR APPLIANCE. THIS MAY VOID THE MANUFACTURER'S WARRANTY AND/OR HINDER EFFECTIVE SERVICING AND MAINTENANCE.

THESE INSTRUCTIONS ARE TO REMAIN WITH THE APPLIANCE AND THE CONSUMER IS TO RETAIN THEM FOR FUTURE REFERENCE.

**WARNING:** If the information in this manual is not followed exactly, a fire or explosion may result causing property damage, personal injury or death.

Do not store or use gasoline or other flammable vapors and liquids in the vicinity of this or any other appliance.

### WHAT TO DO IF YOU SMELL GAS

- Do not try to light any appliance
- Do not touch or activate any electrical switch
- Do not use any phone in your building
- Immediately call your gas supplier from a neighbor's house
- Follow the gas supplier's instructions
- If you cannot reach your gas supplier, call the fire department

**GAS-FIRED**



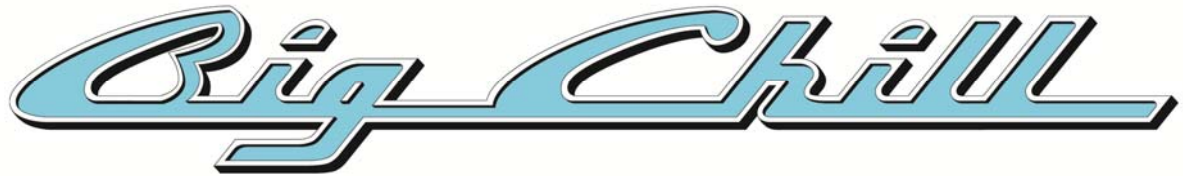

We believe that our success can only be measured by the continuing success of our customers. We achieve customer satisfaction by ensuring that each of our employees understands, meets and exceeds customer expectations. We establish and maintain an environment that encourages all employees to pursue continuous improvement in quality and productivity.

Our quality policy is monitored by the highest levels of management.

We hope you enjoy your new appliance and we THANK YOU again for believing in our product as much as we do.

*The staff and team at Big Chill!*

## WELCOME

...to the exciting world of Big Chill cooking! You have purchased one of the finest appliances available for home use, which shows that you take cooking seriously. As the owner of a new Big Chill appliance you can look forward to years of cooking enjoyment. You will prepare meals with the speed and accuracy of a professional chef right in your own kitchen! All equipment is designed and manufactured to the highest quality standards in the industry specifically to meet the needs of the world's most demanding chefs: you. From simmering to sautéing, baking and broiling these versatile appliances provide the flexibility you need in any cooking application. What's more, this high quality, high-performance appliance is backed by our professional service network from coast to coast to provide you with quick, competent technical service should the need arise. Please take a few moments now to fill in the information below for your future reference. In the event you require parts or service, this information will be needed to ensure you receive the highest quality service we can provide.

DATE OF PURCHASE

DATE OF INSTALLATION

INSTALLER'S NAME

INSTALLER'S ADDRESS

MODEL NUMBER

SERIAL NUMBER

NOTE: WARRANTY SERVICE MUST BE PERFORMED BY AN AUTHORIZED SERVICE AGENT. YOU MAY REQUEST WARRANTY SERVICE BY CALLING 877-842-3269.

**In the Commonwealth of Massachusetts, gas connections must be performed by a licensed plumber or licensed gas fitter.**

# TABLE OF CONTENTS

Introduction .....	2
Welcome.....	3
Table of Contents .....	4
Safety Instructions.....	5
Site Preparation .....	6
Installation .....	7
Unpacking .....	7
Backguard .....	8
Gas Connections.....	9
Electrical Connections.....	10
Ventilation.....	10
Operation.....	11
Before You Turn It On .....	11
Burners .....	11
Oven .....	11
Broiler .....	12
Full Extension Rack .....	12
Cleaning .....	14
Body .....	14
Burners .....	14
Oven .....	14
Helpful Hints .....	15
Care and Maintenance .....	17
Troubleshooting .....	19
Warranty.....	20
Performance Checklist .....	22

## SAFETY INSTRUCTIONS

To avoid personal injury or property damage, please read and follow these important safety precautions.

1. Before any maintenance or repairs are performed, disconnect the appliance from the electric supply.
2. Your appliance should be installed by a qualified gas installation technician. Have the technician show you the exact location of the gas shutoff valve on the incoming gas line so you know how to turn off the gas if necessary.
3. In the event of a power failure, do not attempt to operate the appliance or light any of the burners. This is a gas fired appliance that employs electrical components such as the ignition and safety devices.
4. Do not attempt to repair or replace any part of this appliance unless specifically instructed to do so by this manual. In-warranty service must be performed by an authorized service agency.
5. Do not store flammable materials on or near the appliance. Keep the appliance area clean and free of combustible materials, gasoline and other flammable vapors and liquids. A check before each use to determine that no hazardous materials are in the area is recommended.
6. The push-to-turn control knobs on this appliance are designed to be child-safe, however, not a guarantee of operation. Children should not be left alone or unattended in the kitchen while the appliance is in use.
7. This appliance should not be operated without a properly sized and operational ventilation hood.
8. The ventilation and flue ways of this appliance must remain unobstructed at all times.
9. Additional care should be exercised if your appliance is equipped with a high-shelf. During heavy or continued use this shelf may become hot. Do not place combustible materials or plastics on this shelf.
10. Do not store items of interest to children above the appliance. Children, as well as adults, should never be allowed to sit, stand, or climb on any part of the appliance. Serious injury may occur.
11. Never leave the appliance unattended during use. Boil-overs may occur, causing spills which may ignite.
12. Do not use water on grease fires. Never pick up a flaming pan. It is recommended you purchase a multi-purpose dry chemical or foam-type fire extinguisher for your home. Store it in close proximity to your appliance.
13. If you are flaming liquor or other spirits, and you're appliance is installed under a vent hood, **TURN THE FAN OFF**. The draft created could cause the flames to spread out of control.
14. For your safety, never use your appliance or any other cooking appliance as a space heater to warm or heat the room.
15. Use only dry potholders. Moist or damp potholders on hot surfaces may result in steam burns. Do not allow potholders to touch hot burner areas. Do not use a towel or other bulky material as a potholder.
16. To reduce the risk of burns, ignition of flammable materials, and spillage, the handle of any pot or pan should be positioned so that it does not extend over adjacent burners or the front of the appliance.

### WARNING

**Operation of this product could expose you to carbon monoxide if not adjusted properly. Inhalation of carbon monoxide is known to the state of California to cause birth defects or other reproductive harm.**

## SITE PREPARATION

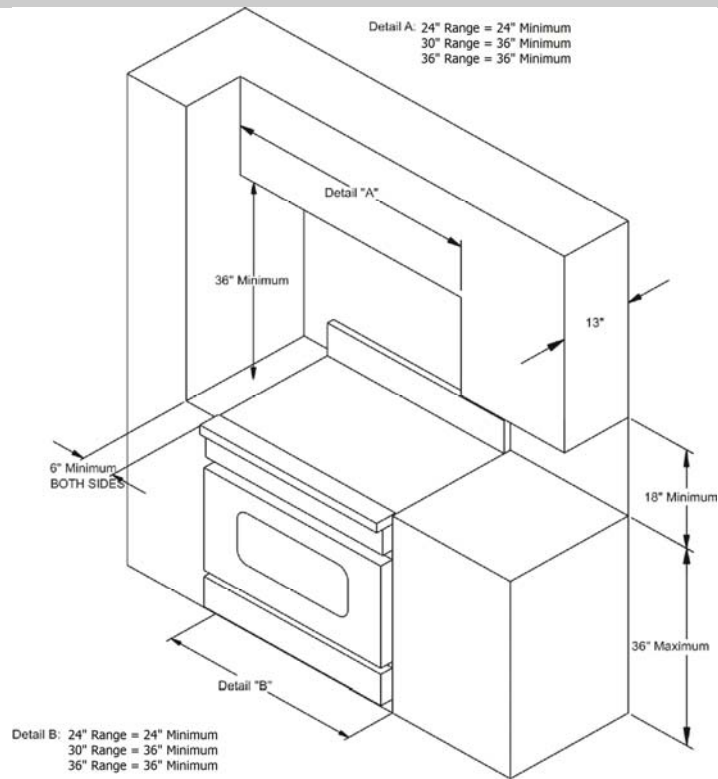

- This appliance has been designed to be installed directly against rear walls and side base cabinets. It cannot be installed directly against tall side cabinets, side walls, tall appliances or base cabinets extending beyond 24 inches [610 mm].
- Side trims must be at least 11/16 inch [17.5 mm] above the adjoining counter top surfaces.
- Any openings in the back wall or the floor of the installation site must be sealed.
- Each gas appliance shall be located with respect to building construction and other equipment to permit access to the appliance. Such access and clearance is necessary for cleaning and servicing.
- Due to its size and weight, a rolling lift jack, air sled or pallet jack should be used to move the appliance into position.
- Do not push against the edges or sides of any appliance in an attempt to slide it into position. Although all metal parts are deburred during the manufacturing process, serious injury could occur if the appliance were to move suddenly while being positioned. We recommend you use gloves during the installation process.
- Do not use the kick panel or oven door handle to push or pull the appliance into position.
- For optimum performance the appliance should be leveled during installation. A carpenter type level should be placed on the unit three ways: side to side; front to back; diagonally.
- Appliances on bullet legs may be leveled by screwing the various leg assemblies in or out. If the appliance is installed in an island or cabinet cut-out the edges should be shimmed with small metal coupons.

## INSTALLATION

### UNPACKING

1. Check the package for damage. If any damage is visible you should mark the bill of lading you sign that there may be concealed damage.
2. Ensure the container is upright. If the container is not upright major damage can occur to your appliance. If damage is discovered, do not refuse delivery. File appropriate freight claims with the shipping carrier. Save all packaging material. Do not contact the manufacturer. Shipping damage claims are to be resolved between the customer and shipping carrier. The manufacturer may assist in resolving any such claims, but such assistance does not relieve you of your responsibility.
3. Move the container as close to its installation location as possible. This will reduce moving and handling your appliance once it is out of its shipping container.
4. Cut the straps holding the carton to the palette. Lift the box directly up and off the appliance. Do not use a hammer. Do not cut the carton with a razor, utility or box cutting knife.
5. Thoroughly inspect your appliance for damage. If damage is discovered, do not refuse delivery. File appropriate freight claims with the shipping carrier. Save all packaging material. Do not contact the manufacturer. Shipping damage claims are to be resolved between the customer and shipping carrier. The manufacturer may assist in resolving any such claims, but such assistance does not relieve you of your responsibility.
6. Remove and unpack any accessories shipped with your appliance. Make sure no hardware or accessories are left to be disposed of unintentionally.
7. Remove shipping bracket from the rear bottom left corner (when facing front of unit) and replacing screws in base of range holding gas connection cut-out in place, see picture left.



Replace Screws

Shipping Bracket

## INSTALLATION

### **BACKGUARD**

All ranges require a backguard. Standard is a 6" with an optional island trim available.

If you are using an island trim, a six inch clearance between the back of the range and a combustible surface is required. If an island trim is to be used without this six inch clearance, the back wall must be non-combustible *and* heat resistant material that extends below the top surface of the range a minimum of six inches.



## INSTALLATION

### GAS CONNECTIONS

1. The installation of this appliance must conform with all applicable local codes. In the absence of local codes, the installation must conform to the latest level of the National Fuel Gas Code, ANSI Z223.1/NFPA 54. In Canada, the installation must be in accordance with the current CAN/CGA B149.1 and B149.2.
2. This appliance can be configured to work with either natural gas or LP gas. Verify that the appliance and the incoming gas supply are compatible. Check the rating plate.
3. The gas supply line must be the same size or larger than the gas inlet of the appliance. Your appliance has either a ½" NPT or ¾" NPT gas inlet connection. We recommend the supply line be ¼" NPT larger than the gas inlet of the appliance.
4. Sealant used on pipe joints must be resistant to LP gas.
5. An installer provided manual shut-off valve must be installed in the gas supply line ahead of the appliance. This shut-off must be easily accessible in case of emergency.
6. All gas cooking equipment must have a pressure regulator on the incoming service line for safe and efficient operation. This appliance is equipped with such a gas pressure regulator. Incoming gas pressure should be checked with a manometer. The correct manifold pressure for natural gas is 5.0" wc. For LP gas the correct manifold pressure is 10" wc.
7. Incoming line pressure upstream of the appliance should be 1.0" wc greater than the operating manifold pressure. Service pressure may fluctuate for a variety of reasons. Under no circumstances should the factory installed regulator be removed or by-passed.
8. The factory installed pressure regulator will withstand an input pressure of ½ PSI (12" wc). If the incoming pressure exceeds the maximum rating, a customer supplied step-down regulator is required.
9. The appliance and its individual shut-off valve must be disconnected from the gas supply line during any pressure testing in excess of ½ PSI [3.5 kPa].
10. The appliance must be disconnected from the gas supply by closing its individual shut-off during any pressure testing less than ½ PSI [3.5 kPa].
11. Check to see that all installer supplied pipes and fittings are clear of debris, threading chips or other foreign particles before connecting the appliance to the supply line. Such particles will clog orifices and/or valves when pressure is applied. **Service to clean such clogs is not covered by your warranty.**
12. The incoming gas supply is brought from the inlet pipe. This is the only connection required via the installer-supplied shut-off valve.
13. If the appliance is to be installed with flexible couplings and/or a "quick disconnect" the installer must use a commercially approved AGA Design certified flexible connector at least ½" NPT that complies with ANSI Z21.41. In Canada, the connector must comply with CAN 16.10-88 and the "quick disconnect" device must comply with CAN 16.19M-79 and installed with a strain relief device.
14. Before putting the appliance into service test all gas connections for leaks. Use a soapy solution. **DO NOT USE AN OPEN FLAME TO CHECK FOR LEAKS.** Such a procedure is dangerous, and it may not detect all the small leaks that a soapy solution will.
15. Air shutter adjustments are preset at the

## INSTALLATION

factory. These adjustments may need to be redone and/or fine tuned by the installer. These adjustments are normal. They are the responsibility of the qualified installer and are not covered by your warranty.

16. A gas conversion performed in the field may void your warranty. Contact your Big Chill service department for information regarding the conversion from one type of gas supply to another.

### ELECTRICAL CONNECTIONS

1. The installation of this appliance must conform with all applicable local codes. In the absence of local codes, the installation must conform to the latest level of the National Electric Code, ANSI/NFPA 70.
2. This appliance is equipped with a standard three prong polarized, NEMA 5-15P line cord to be plugged into a 120Volt 15 Amp outlet.
3. Removing the grounding prong from the plug will void the manufacturer's warranty.
4. The cord exits the appliance at the lower rear toward the right (viewed from front) side.
5. If the electrical supply is not turned on or is interrupted the appliance will not operate.
6. The applicable wiring diagram for this appliance is affixed to the appliance.
7. The circuit where you plug your appliance must be grounded and polarized.
8. We recommend the circuit for your appliance be a non-GCFI dedicated line.
9. It is recommended that your circuit never include a microwave oven.

### WARNING

**This appliance is equipped with a three-pronged grounding plug for your protection against shock hazard and should be plugged directly into a properly grounded receptacle. Do NOT cut or remove the grounding prong from this plug. If the appliance is not grounded or its polarity is reversed, severe shock hazards can exist.**

### VENTILATION

Proper ventilation is highly important for good operation. This appliance must be installed under a properly designed canopy hood.

A strong exhaust fan can create a vacuum in the room. For proper air balance, work with a HVAC professional and/or contactor to properly size your hood and its exhaust fan. It is recommended that your exhaust hood be powerful enough to move a minimum of 300 cfm.

### IMPORTANT

**ALL GAS BURNERS NEED SUFFICIENT AIR TO OPERATE AND LARGE OBJECTS SHOULD NOT BE PLACED IN FRONT OF THIS APPLIANCE WHICH WOULD OBSTRUCT THE AIR FLOW THROUGH THE FRONT. OBJECTS SHOULD NOT BE PLACED ON THE REAR BACKGUARD WHILE IN USE. THIS COULD OBSTRUCT THE VENTING SYSTEM OF THE OVEN'S FLUE PRODUCTS.**

## OPERATION

### BEFORE YOU TURN IT ON....

- As part of the installation, protective plastic wrappers on stainless steel surfaces should be removed. These wrappers must be removed before operation.
- New appliances are wiped clean with various cleaners and solvents to remove visible signs of dirt, oil and grease before leaving the factory. After installation, performance checks and adjustments, the appliance should be allowed to heat to burn off any such oils from internal parts. The presence of such coatings is normal as part of the manufacturing process. Follow the Oven Burn-Off Procedure in the Care and Maintenance section of this booklet. The ventilation hood should be turned on and the area well ventilated to allow fumes to escape safely.
- Removable parts should be washed with hot soapy water, well rinsed and wiped dry.
- Complete and mail your Performance Checklist to validate your warranty.

### BURNERS

- Remove the top grates and thoroughly wash them with hot soapy water, rinse and wipe dry. Extended exposure to moisture may cause these cast parts to rust.
- To light a burner, turn the corresponding control knob to HIGH.
- This knob is a gas control valve and an electric switch. Turning to the High position begins the ignition sequence.
- The ignitors begin to “click”. As gas flows through the piping to the burner, the sparking ignites it. After the flame lights, the ignitor senses its heat, and the “clicking” automatically stops.
- ALL burners light at the HIGH setting.
- Burners are equipped with a re-ignite feature in case the flame is extinguished for

any reason.

- At the High setting, flames should be sharp with blue tips. Some yellow may appear depending on the type of gas being burned.
- Turn the flame lower so it does not wrap around the bottom edge of the pan.
- Burners may be operated at any knob position between LOW and HIGH.
- Never operate the burner with the knob between the HIGH and OFF position. If the flame goes out it will not re-ignite, and gas leaks could occur.
- When you turn the valve off, the flame may linger several seconds until all the gas in the feeder tube is burned up.

**NEVER use this appliance as a space heater to heat or warm the room. Doing so may result in carbon monoxide poisoning and overheating of the oven.**

### OVEN

- Before turning on your oven for the first time perform the Oven Burn-Off Procedure in the Care and Maintenance section of this booklet. Remove the oven racks, and rack guides and wash them with hot soapy water. Thoroughly rinse and dry items and replace them. To light the oven push in and turn the oven knob counter clockwise to the temperature setting you wish to cook at - 150°F to 500°F. The oven ignitor will glow brightly. The gas valve will open allowing the flow of gas into the burner. The oven ignitor will light the gas coming out of the ports on the burner.
- During the first few minutes of operation, a mild condensation may appear on the internal side of your oven door or the door windows. This is normal and will disappear as the oven warms.

## OPERATION

- Allow the oven to pre-heat at least 10 minutes before turning on the convection fan.
  - Allow the oven to pre-heat 20 - 30 minutes to be fully to temperature for baking.
  - Never place any pan or food for baking directly on the bottom of the oven. Always use a rack in at least the lowest position.
  - Center pans on the rack for best hot air circulation around the food. If using multiple pans and the convection fan leave at least one inch of space between them.
  - Never let food come in contact with internal oven surfaces.
  - Your oven is not a storage compartment. Do not place food or articles in the oven when you are not using it.
- to a blanket of blue flame . After a few minutes the ceramic blocks will begin to glow brightly and radiate infrared heat.
  - Once the broiler reaches proper temperature it will cycle on and off.
  - It is not necessary to pre-heat the broiler prior to use.
  - The oven burner and broiler will not operate at the same time.
  - Do NOT use the convection fan while broiling.

### WARNING

Never cover any slots, holes or passages in the oven bottom or cover an entire rack with any material, such as aluminum foil. Doing so blocks airflow through the oven and may cause carbon monoxide poisoning. Aluminum foil linings may also trap heat creating a fire hazard.

### OVEN BROILER

- Remove everything from the oven racks. Properly position the rack and the food you will broil to the correct distance from the broiler. Remove the food for lighting.
  - Push in and turn the oven thermostat knob counter clockwise to the broil “BR” position.
  - The broiler ignitor will begin to glow brightly, the gas valve will open to allow gas flow and the ceramic burners will light.
  - The infrared oven broiler may have an initial bellowing flame that will even out
- This model comes equipped with one full extension rack. This allows you to pull out the rack 100% from the oven cavity for easier loading and unloading of large items.
  - This rack is originally located on the bottom position of the rack guides.
  - This rack can be moved to the other positions of the rack guides at your convenience.

To move to another rack position:

- This should only be performed when the oven is cool and the rack is empty.
- Push the rack fully into the oven.
- Grasp the slides on each side of the rack and lift the front up slightly.
- Pull the rack towards you evenly. There is a tab at the rear of each slide positioned over and under the rack guide wire.
- Once removed the extension rack can be placed at another rack position by revers-

### FULL EXTENSION RACK

#### WARNING

Do not put your face near the infrared broiler when lighting. Keep the door closed during lighting and broiling. Open the door only to insert or remove food.

## OPERATION

- ing the process.
- Grasp the slides on each side of the rack. The slides should be fully closed during this procedure. If extended, they can be closed by standing the back end of the rack on the floor.
  - With the rack angled upwards, insert the top tab over the rack guide position you wish to use. Tilt down slightly so the bottom tab can be under the wire.
  - Push back evenly. If you do not push evenly the slide may bind until you straighten it out.
  - When the rack is pushed all the way back, there is a hook at the front of each slide that must go over the front edge of the rack guide wire to lock everything into position.

## CLEANING

### BODY

- All stainless steel, chrome and painted parts should be cleaned regularly with hot soapy water.
- Commercially available stainless steel cleaners may be used on stainless steel. Be sure to follow manufacturer's instruction for use.
- Do NOT use steel wool or metal pads or other abrasive cleaners. These surfaces are painted or polished and using these products will scratch and damage your finish.
- In extreme conditions use a cloth soaked in hot water to sit on the soiled area to soften the residue and allow it to be safely cleaned off. LIGHT scraping with a rubber or nylon spatula may be used to finish lifting residue off.
- Do NOT use a metal knife, spatula or similar or any metal tool to scrape these surfaces.
- Do NOT permit citrus or tomato juices to sit and dry on these surfaces. Wipe such spills immediately. Citric acid will discolor stainless steel.

### BURNERS

- The top grates of your appliance may be effectively cleaned with hot soapy water.
- In the event of heavy soiling, a commercially available oven cleaner may be safely used on these parts. Be sure to follow the manufacturer's instructions for use. Ensure the cleaning chemical does not contact any painted surfaces on your appliance.
- To insure proper fit and safe use replace the top grates to their proper position.

### OVEN

- The oven interior is coated with porcelain enamel. It may be cleaned by using commercially available oven cleaners.
- Be sure to follow manufacturer's instructions for use.
- Ensure the cleaning chemical does not come in contact with any painted surfaces on your appliance.
- You may want to line your floor with several layers of newspaper to catch any drips or run-off of cleaning chemicals.
- NEVER use ammonia to clean a warm or hot oven. Be sure to well ventilate the area.
- Baked on spills may be loosened with a nylon pad or household cleaner.
- DO NOT use steel wool or metal pads to clean the interior oven surface. They may damage or scratch off the enamel coating.
- The door window may be safely cleaned with the same methods.
- Do not rub or scrub on the door gasket material. Damage to the material or the door seal may occur.
- Oven racks and side wall rack guides may be removed for cleaning. If they fit they are safe to run through your dishwasher.
- The convection oven fan must be cleaned periodically of any food or foil particles. Grease build-up may be cleaned with commercial cleaners. Use caution not to cut yourself on the edges of the fan blades.
- Do not try to clean the infrared broiler surface.

## HELPFUL HINTS

### TOP BURNERS

- Ensure the top grates are properly positioned so your cooking pan will sit flat and level.

### OVEN

- Pre-heat the oven thoroughly before use (20-30 minutes).
- Never use foil to line the oven bottom or oven racks. This will block the heat flow and can create a hazard.
- Never place anything directly on the bottom of the oven cavity. This obstructs the airflow and will cause uneven results.
- Place items on oven racks evenly and centered for even baking.
- When loading the oven, work as quickly as possible to prevent loss of heat.
- When practical, start cooking the lowest temperature product first and gradually work up to the higher temperatures.
- Leave a minimum of one inch between pans on the same rack for even baking.
- Roast meat with the fat side facing up for self-basting and minimal shrinkage.

### CONVECTION OVEN

- As a general rule, the temperature should be reduced 25°F to 50°F from that used in a standard/conventional oven. Cooking time may also be shorter. We suggest closely monitoring the first batch of each product prepared.
- Cooking times and temperatures will vary depending upon such factors as size of the load, temperature, mixture of products (particularly moisture) and density of products.
- Keep a record of the times, temperature and load sizes you establish for various products. Once you have determined these, they will be similar for succeeding

loads.

- Center pans on racks and load each shelf evenly to allow for proper air circulation within the cavity.
- When baking, weigh or measure the product in each pan to assure even cooking.
- Muffin pans should be placed in the oven back to front or with the short side of the pans facing the front. This results in the most evenly baked product.
- When re-thermalizing frozen casseroles, preheat the oven 100° over the suggested temperature. Return the cooking temperature to the normal setting once the oven is loaded. This will help compensate for the introduction of a large frozen mass into the cavity.

### THERMAL vs. CONVECTION BAKING

Thermal baking refers to the use of traditional heat circulation by means of natural air flow - fan not turned on. In thermal baking, heat is emitted by a burner below the oven cavity. The heat rises through the oven cavity and is transferred to the food and oven interior. The continuous supply of heat from the burner causes the heated air to circulate within the oven.

A convection oven is equipped with a motor-driven fan, usually located at the rear of the oven cavity. This fan circulates heated air

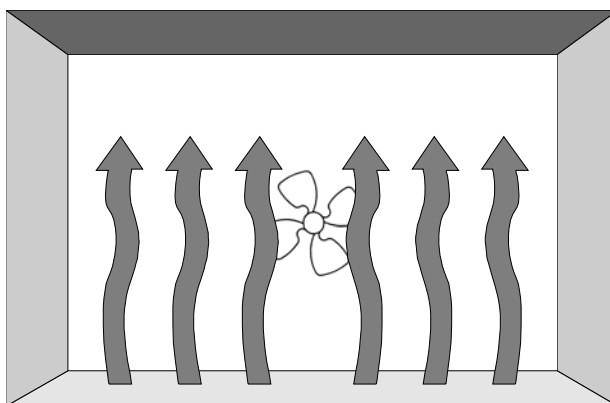

## HELPFUL HINTS

within the oven resulting in even heat distribution, and a consistent temperature throughout the cavity.

Convection ovens can handle larger loads than standard ovens with a high degree of



consistency. In a convection oven, cool air is replaced by hot air quickly and consistently, providing better browning of baked goods and poultry. Meats are seared and self-basted, resulting in more flavor and less shrinkage as well as quicker cooking times.

### Problems/Solutions

- If cakes are dark on the sides and not done in the center - *Lower oven temperature*
- If cakes edges are too brown - *Reduce number of pans or lower oven temperature*
- If cakes have light outer color - *Raise oven temperature*
- If cake settles slightly in the center - *Bake longer or raise oven temperature slightly. Do not open the doors too often or for long periods of time*
- If cake ripples - *Overloading pans or batter is too thin*
- If cakes are too coarse - *Lower oven temperature*

- If pies have uneven color - *Reduce number of pies per rack or eliminate use of bake pans*
- If cupcakes crack on top - *Lower oven temperature*
- If meats are browned and not done in the center - *Lower oven temperature and roast longer*
- If meats are well done and browned - *Reduce cooking time*
- If meats develop a hard crust - *Lower oven temperature*
- If rolls have uneven color - *Reduce the number or size of pans*



## CARE AND MAINTENANCE

### OVEN BURN-OFF PROCEDURE

- As part of installation protective plastic wrappers on stainless steel surfaces should be removed. These wrappers must be removed before operation.
- New appliances are wiped clean with various cleaners and solvents to remove visible signs of dirt, oil and grease before leaving the factory.
- Before turning on your oven for the first time, remove the oven racks, and rack-guides and wash them with hot soapy water. Thoroughly rinse and dry items and replace them.
- During initial start-up, after all performance checks and adjustments, the oven should be allowed to heat to burn off any oils or solvents from internal parts. The presence of such coatings is normal as part of the manufacturing process.
- The ventilation hood should be turned on and the area well ventilated to allow fumes to escape safely.
- Follow the user instructions to light the oven. Once lit set the temperature adjustment to 300°.
- Allow the oven to pre-heat at least 10 minutes before turning on the convection fan.
- After approximately 30 minutes increase the temperature setting to 450° and allow to heat for another hour.
- During this process a strong odor and/or some smoke may be observed as any oils and solvents on internal parts are burned off. This is the primary reason for the burn-off process. Make sure your ventilation fan is operating during this procedure.

### AIR & GAS MIXTURE ADJUSTMENTS

Air and gas mixtures are preset at the factory. These adjustments may need to be redone and/or fine tuned by the installer. These adjustments are normal. They are the responsibility of the qualified installer and are not covered by your warranty.

## CARE AND MAINTENANCE

### TOP BURNER LOW FLAME ADJUSTMENT

1. Ensure gas pressure regulator is set properly. This setting is typically checked and adjusted by a service agent using a manometer.
2. Turn the burner on low.
3. Remove the burner knob from the valve stem by pulling straight toward you.
4. Insert a small slotted screwdriver blade into the “D” shaped valve stem inserting it into the adjusting screw.
5. Turn the adjusting screw 1/8 of a turn at a time - clockwise to lower the flame, counter-clockwise to raise the flame.
6. Replace knob by aligning the “D” shaped cut-out and pressing straight onto the valve stem

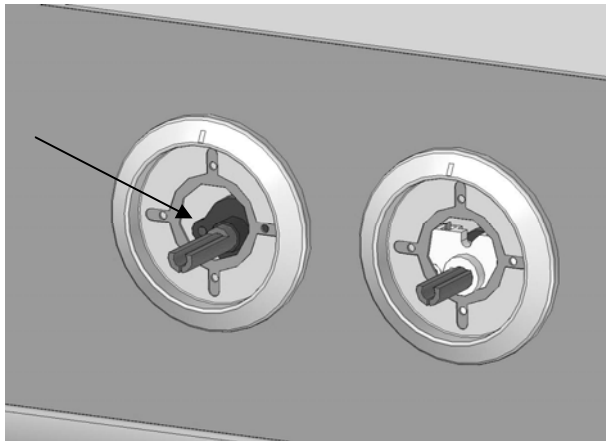

### OVEN BURNER AIR SHUTTER ADJUSTMENT

Before attempting to adjust the oven burner air shutter, Ensure the following has been checked and is correct:

- Proper gas type - match serial plate
- Proper regulator setting
- Orifice aligned - parallel with the venturi to the burner

After verifying the gas, regulator and orifices adjust the air shutter by:

1. Remove bottom panel from inside oven

cavity.

2. Remove lower kick panel held in place by two sheet metal screws.
3. Pre-heat oven for 10-15 minutes. DO NOT turn on convection oven fan during adjustment procedure.
4. Use a screwdriver to loosen the air shutter tightening screw.
5. Turn the air shutter as required to adjust the flame - open gap for “lazy” flame, close gap for “lifting” flame.
6. Test burner.
7. If necessary, turn off burner and readjust.
8. Turn off burner, tighten shutter screw and replace kick panel and oven bottom.

### REPLACING OVEN LAMPS

Your oven comes with one. When changing a burned out lamp is necessary, first ensure the oven is cool. Grasp the clear globe lens and

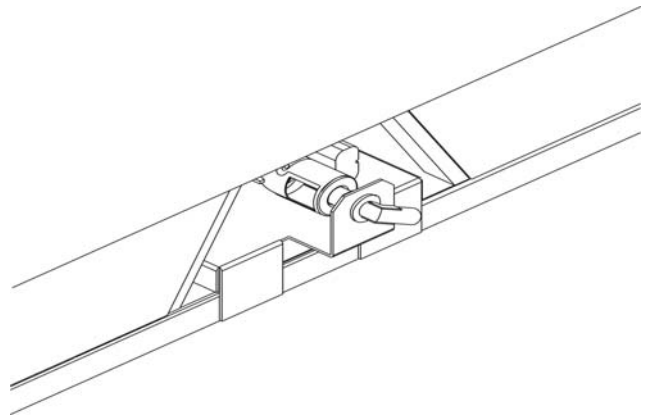

turn counter clock-wise to loosen. Replace the burned out lamp with a 40 watt Appliance style bulb only. Do not use normal lamp bulbs - they are not suited to the higher temperatures of your oven. Replace the clear globe.

## TROUBLESHOOTING

PROBLEM	SOLUTION
Burner won't light—no “clicking” from ignitor	Ensure appliance is plugged in. Ensure circuit is not tripped or fuse blown.
Burner won't light—”clicking”, no flame	Ensure gas is turned on. Ensure burner ports are clean. Try a second burner for same or different result. Ensure electrode is plugged in. Ensure electrode is properly lined up. Ensure electrode is not cracked—spark not in correct place.
Burner lights, “clicking” won't stop	Ensure electrode wires are properly connected after cleaning. Call for service.
Consistent lazy (yellow tipping) or lifting flame	Call for service to adjust air and gas mixture. (Some yellow tipping is acceptable with LP and may not require an adjustment)
Oven won't light	Ensure range is plugged in. ensure gas is turned on - test top burner. Check hot surface ignitor for red glow, call for service.
Broiler won't light	Ensure range is plugged in. ensure gas is turned on - test top burner. Check hot surface ignitor for red glow, call for service
Oven light not on	Ensure range is plugged in. Change light bulb - 40 watt Appliance only.
Convection fan doesn't turn	Ensure range is plugged in. Call for service.

# WARRANTY

## **WHAT IS COVERED?**

Big Chill provides the following limited warranties to the original retail purchasers of Products sold and installed in the continental United States and Canada on or after February 22, 2002:

**Initial Seven (7) Day Limited Warranty.** Big Chill warrants that all cosmetic components of its Products will, under normal use and service, be free from defects in materials and workmanship for a period of seven (7) calendar days from the date of delivery (the "Warranty Period") to the original retail purchaser. For purposes of this Limited Warranty, cosmetic components include top grates, ring grates, plate rail, kick panel, body sides, glass, control panel, door panel, back guards, oven seals, light bulbs, and enameled parts. All warranty claims for cosmetic items must be reported immediately within seven calendar days of delivery or such claims will not be honored. Please refer to your installation checklist to activate your limited warranty.

**One (1) Year Limited Warranty.** Big Chill warrants that all functional components (except cast iron burner tops) of its Products will, under normal use and service, be free from defects in materials and workmanship for a period of one (1) year from the date of delivery (the "Warranty Period") to the original retail purchaser. For purposes of this Limited Warranty, functional components include all components of the Product other than the cosmetic components covered by the initial seven day limited warranty and the cast iron burner tops covered by the 10 year limited warranty. Floor models are not covered under the One (1) Year Limited Warranty but are covered by a Ninety (90) Day Labor and One (1) Year Limited Parts Warranty with proof of date of install and a completed Installation Checklist. Demonstration units are not covered under the One (1) Year Limited Warranty. Please refer to your installation checklist to activate your limited warranty. **Failure to send a complete and accurate copy of the installation checklist within 15 days of installation will invalidate your limited warranty.**

**Ten (10) Year Limited Warranty.** Big Chill warrants that all functional components of its cast iron burner tops will, under normal use and service, be free from defects in materials and workmanship for a period of ten (10) years from the date of delivery (the "Warranty Period") to the original retail purchaser. Please refer to your installation checklist to activate your limited warranty. **Failure to send a complete and accurate copy of the installation checklist within 15 days of installation will invalidate your limited warranty.**

If any Product fails to comply with the foregoing Limited Warranties during the applicable Warranty Period, Big Chill will, at its option, either (i) pay the reasonable labor and material costs to have the Product repaired by a factory authorized service agent; (ii) replace the Product or defective component of the Product; or (iii) if in Big Chill's sole judgment circumstances are such as to preclude the remedying of any breach of warranty by repair or replacement, then Big Chill will refund the purchase price paid by the original purchaser. All repairs or replacement service must be performed by a factory authorized service agent. Additionally, all Products must be accessible for service in the home and must be accessible via public highways within 100 miles roundtrip of a factory authorized service agent. The purchaser will be responsible for the cost of additional mileage, non-standard service and special equipment to remove the Product for service so that there is accessibility on all sides of the Product.

The repair or replacement of the Product or the return of the purchase price will be the purchaser's sole and exclusive remedy for any breach of this Limited Warranty or any other claim with respect to the Product, including those claims based on contract, warranty, or tort. In no event will Big Chill's liability for any defective Product exceed the purchase price thereof. This exclusive remedy will not be deemed to have failed of its essential purpose so long as Big Chill is willing and able to repair and/or replace defective Products in the manner prescribed herein or to provide a refund if, in Big Chill's sole judgment, repair or replacement is not feasible or appropriate under the circumstances.

# WARRANTY

## **WHAT IS NOT COVERED?**

This Limited Warranty is the sole and exclusive warranty provided for the Product and extends only to original retail purchasers in the continental United States and Canada. This Limited Warranty is not transferable to any subsequent purchasers or users. If any implied warranties arise under any applicable law (including, but not limited to, implied warranties of merchantability and fitness for particular purpose), then the duration of those implied warranties will last only as long as the express warranties stated above.

**Big Chill will not under any circumstances be liable for any special, indirect, incidental or consequential damages of any kind, including but not limited to loss of business or profits, loss of use, or installation or removal costs.** Nor will Big Chill be responsible for any shipping costs related to the repair or replacement of any Product under this Limited Warranty. Some States do not allow the exclusion or limitation of incidental or consequential damages or limitations on how long implied warranties last, so the above limitations may not apply to you.

This Limited Warranty does not apply to commercial usage or to any Products installed in any non-residential settings such as day cares, bed and breakfasts, hotels, nursing homes, churches, etc. This Limited Warranty also does not cover, and specifically excludes, chipping porcelain, calibrations and normal adjustments after installation and setup, burner adjustments, normal care and maintenance, cleaning of parts, shipping damage, discoloration of the griddle, rust, gasket materials, ceramic materials, and fuses. Additionally, there is no warranty coverage for any Products that fail or have been damaged due to alterations or modifications; abuse; misuse; neglect; improper installation, instruction, handling, operation, maintenance or storage; accidental or intentional damage; normal wear and tear; unauthorized service or repairs, including unauthorized adjustments or calibrations performed on the Product; damage from natural disasters, fires, floods, earthquakes or other acts of God; loss of electrical power to the Product for any reason; alteration for outdoor use; damage due to the use of harsh chemicals (e.g., cleaning products improperly applied); or any other circumstances beyond Big Chill's control. This Limited Warranty is also invalid if the original factory installed serial number has been altered or removed from the Product.

The Purchaser is responsible for proper installation and normal care and maintenance of the Product. This warranty gives you specific legal rights, and you may also have other rights which vary from State to State.

## **OBTAINING WARRANTY SERVICE**

All warranty claims must be reported to Big Chill, P.O. Box 892, Boulder, CO 80306 prior to the expiration of the applicable Warranty Period. If a warranty claim relates to cosmetic parts, any such claim must be reported to Big Chill within seven (7) calendar days after the Product has been delivered. The purchaser must call the factory at the toll free 877-842-3269 to report a warranty claim or to obtain information about warranty service. If any warranty claim is not submitted as required by this Limited Warranty, any such claim will be invalid and will not be honored. At the time the warranty claim is made, the purchaser must provide the model number of the Product, the serial number of the Product, proof of delivery, a description of the claimed defect, and proof of purchase of the Product, including the original retail receipt or invoice to establish the Warranty Period. Big Chill must also be given an opportunity to inspect any defective Product.

All warranty repairs must be performed by a factory authorized service agent. Service will be provided during normal business hours. The purchaser will be responsible for any labor performed at overtime or premium rates. The purchaser is also responsible for making the Product accessible for service.

# PERFORMANCE CHECKLIST

This checklist has been developed to assure proper installation of your appliance  
 To validate your warranty you must mail or fax this form and a copy of your receipt to:  
 Warranty Department, Big Chill, PO Box 892, Boulder, CO 80306, Fax (720) 565-0650

Customer Information (Please Print)

Product Information (Please Print)

Name: \_\_\_\_\_ Model No: \_\_\_\_\_  
 Address: \_\_\_\_\_ Serial No: \_\_\_\_\_  
 City: \_\_\_\_\_ Purchase Date: \_\_\_\_\_  
 State: \_\_\_\_\_ Installation Date: \_\_\_\_\_  
 Zip Code: \_\_\_\_\_ Installer's Name: \_\_\_\_\_  
 E-mail: \_\_\_\_\_ Company: \_\_\_\_\_  
 Telephone: \_\_\_\_\_ Telephone: \_\_\_\_\_

CHECK ALL THAT APPLY

Appearance and Aesthetics

- Exterior
- Top section
- Oven interior

Electrical Connection

- Correct voltage
- Grounded outlet
- Polarized outlet
- No GFCI

Installation

- Proximity to cabinets
- Level
- Backguard in place
- Ventilation system
- Read User Manual
- Review safety instructions

Gas Connection

- Verify fuel—\_\_\_\_ Nat \_\_\_\_ LP
- Gas shut-off present and accessible
- Supply line properly sized
- Supply pressure checked
- Operating pressure checked
- All connections checked for leaks

Ignition

- Top Burners
- Oven Burner
- Infrared Broiler

Flame Adjustment

- Top Burners
- Oven Burner
- Infrared Broiler

Air/Gas Mixture

- Top Burners
- Oven Burner
- Infrared Broiler

Valve Operation

- Top Burners
- Oven Burner
- Infrared Broiler

Controls

- Burner knobs
- Thermostats
- Convection oven fan & switch
- Oven light switch

Oven Door

- Alignment
- Door seal
- Hinges

CUSTOMER COPY

# PERFORMANCE CHECKLIST

This checklist has been developed to assure proper installation of your appliance  
 To validate your warranty you must mail or fax this form and a copy of your receipt to:  
 Warranty Department, Big Chill, PO Box 892, Boulder, CO 80306, Fax (720) 565-0650

Customer Information (Please Print)

Product Information (Please Print)

Name: \_\_\_\_\_ Model No: \_\_\_\_\_  
 Address: \_\_\_\_\_ Serial No: \_\_\_\_\_  
 City: \_\_\_\_\_ Purchase Date: \_\_\_\_\_  
 State: \_\_\_\_\_ Installation Date: \_\_\_\_\_  
 Zip Code: \_\_\_\_\_ Installer's Name: \_\_\_\_\_  
 E-mail: \_\_\_\_\_ Company: \_\_\_\_\_  
 Telephone: \_\_\_\_\_ Telephone: \_\_\_\_\_

<b>CHECK ALL THAT APPLY</b>
-----------------------------

Appearance and Aesthetics

- Exterior
- Top section
- Oven interior

Electrical Connection

- Correct voltage
- Grounded outlet
- Polarized outlet
- No GFCI

Installation

- Proximity to cabinets
- Level
- Backguard in place
- Ventilation system
- Read User Manual
- Review safety instructions

Gas Connection

- Verify fuel—\_\_\_\_ Nat \_\_\_\_ LP
- Gas shut-off present and accessible
- Supply line properly sized
- Supply pressure checked
- Operating pressure checked
- All connections checked for leaks

Ignition

- Top Burners
- Oven Burner
- Infrared Broiler

Flame Adjustment

- Top Burners
- Oven Burner
- Infrared Broiler

Air/Gas Mixture

- Top Burners
- Oven Burner
- Infrared Broiler

Valve Operation

- Top Burners
- Oven Burner
- Infrared Broiler

Controls

- Burner knobs
- Thermostats
- Convection oven fan & switch
- Oven light switch

Oven Door

- Alignment
- Door seal
- Hinges

MAIL-IN COPY