



The Welding Accessory Experts™

Piranha 2 Medium-duty Tungsten Grinder
Operations Manual

ARC-ZONE.COM, Inc. • 2091 Las Palmas Drive Ste. C • Carlsbad, CA 92011-1551
Tel: 760.931.1500 • 800.944.2243 • Fax: 760.931.1504 • E-Mail: info@arc-zone.com
www.arc-zone.com

Copyright 2007, Arc-Zone.com®, Inc. All Rights Reserved

Thank you for purchasing the Piranha 2 Medium-duty Precision Tungsten Electrode Grinder from Arc-Zone.com. Your new grinding machine is made in the USA and comes with a one-year warranty against manufacturing defects.

Piranha 2 Medium-duty Precision Tungsten Electrode Grinder

Features:

- Solid, compact and durable construction
- Can be used in horizontal or vertical position
- Longitudinal grinding for improved arc stability
- Angle scale for quick setup and repeatability
- Consistently grind electrode sizes .040 (1.0mm), 1/16" (1.6mm) and 3/32" (2.4mm)
- Easy to use tip-flat grinding position
- Electrode notching area for simple cut-off
- Wide range of included grinding angles
- Double-sided diamond wheel provides long wheel life.





1-800-944-2243
www.arc-zone.com

Piranha 2 Operations Manual: Page 3

UNPACKING:

Arc-Zone® takes great pride in producing and delivering quality products. If your product was damaged in transit, please contact your Arc-Zone® account manager immediately.

After unpacking your new grinder, you should have these items:

- The Piranha 2 Medium-duty Tungsten Grinding Machine from Arc-Zone.com.
- One 7/64" Allen wrench used to remove precision diamond grinding wheels.
- A package with this manual, warranty card, and other materials. Please read the manual before proceeding.

Place the grinder on a flat surface with enough free space on each side for proper ventilation and to allow you to comfortably prepare electrodes. Make sure the power switch is in the off position (pointing down) plug the grinder into a "grounded" electrical outlet. Switch the power on and you are ready to begin preparing precision ground electrodes!

DESCRIPTION:

The Piranha 2 Medium-duty Precision Tungsten Grinding Machine is an affordable solution for preparing precision ground tungsten electrodes quickly and easily. Precision electrode grinding benefits:

- Long-lasting diamond wheel delivers consistent high-quality longitudinal ground finish.
- Comprehensive included grind angle (taper) adjustment up to 60°.
- Tip-flat grinding option allows for simple tip-flat preparation.
- Universal collet accommodates electrode sizes .040 (1.0mm), 1/16" (1.6mm), and 3/32" (2.4mm)
- Tungsten notching -- cutting option.

The Piranha 2 Medium-duty precision grinding machine allows operators to diamond grind electrodes consistently and accurately for improved weld quality and increased productivity. Precision ground electrodes deliver extended arctime, minimized arc wander, electrode spitting, shedding and weld inclusions.

ARC-ZONE.COM, Inc. • 2091 Las Palmas Drive Ste. C • Carlsbad, CA 92011-1551
Tel: 760.931.1500 • 800.944.2243 • Fax: 760.931.1504 • E-Mail: info@arc-zone.com
www.arc-zone.com



1-800-944-2243
www.arc-zone.com

Piranha 2 Operations Manual: Page 4

SPECIFICATIONS:

Motor: 1/10 Hp, 8000rpm, 1.5 Amps, and 115 Volts @ 60 HZ
(Optional 220Volt, 50/60 Hz motor available, specify when ordering)

Grinding Wheels: Double-sided diamond impregnated wheel, for precision grinding of tungsten electrode diameters .040 (1.0mm), 1/16" (1.6mm), and 3/32" (2.4mm)

Weight: 6.5lbs. (2.95kg)

WARRANTY:

The Piranha 2 Medium-duty Precision Tungsten Grinder comes with a one-year parts and labor warranty (excluding diamond wheel). Warranty excludes "excessive" abuse or improper handling. Note: This is a precision machine and should be treated accordingly.

SAFETY INFORMATION: Read Safety Precautions Carefully.

Note: This Precision Machine Is Designed To Grind Tungsten Electrodes Only!

- When not grinding electrodes, turn grinder off for safety purposes decreased wear on the precision electric motor.
- Wear proper safety apparel. Do not wear loose clothing, neckties, rings, bracelets, or other jewelry, which may get caught in the machine.
- Wear safety glasses and face mask.
- Never operate power tools when tired, intoxicated, or when taking medication that cause drowsiness.
- Use a grounded three-prong-plug, and plug directly into a three-prong-outlet.
- Keep visitors a safe distance from work area.
- Always unplug grinder prior to inspection.
- Read this manual thoroughly for specific adjustments and operating procedures.
- To ensure consistent electrode preparation, replace damaged parts.
- Make sure that the grinder is off before plugging it in.
- Do not apply extreme force to the tungsten while grinding. This may cause your grinder to jam or cause premature grinding wheel wear.
- Never leave the grinder unattended while running.
- Turn the grinder off first and do not leave it until it comes to a complete stop.
- Know your grinder; learn its operation, applications and limitations.

ARC-ZONE.COM, Inc. • 2091 Las Palmas Drive Ste. C • Carlsbad, CA 92011-1551
Tel: 760.931.1500 • 800.944.2243 • Fax: 760.931.1504 • E-Mail: info@arc-zone.com
www.arc-zone.com

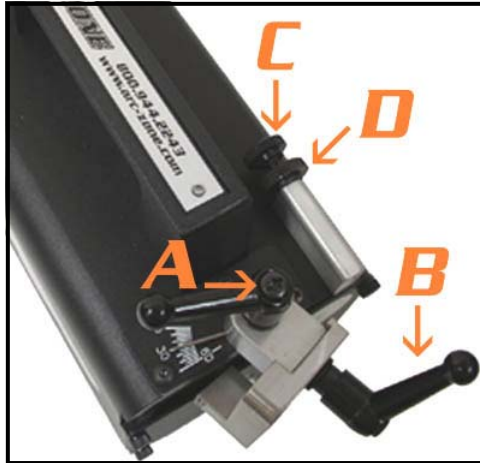

PREPARING ELECTRODES

THE SET UP PROCEDURE:

With the power turned off, select the Included Angle you would like to grind by loosening Knob "A" turn the Collet Arm on its axis until the Pointer is directed at the Grind Angle Scale, re-tightening Knob "A".

Next, insert tungsten through the appropriate Collet Hole in the Universal Collet, observing the height at which the tungsten contacts the wheel.

Use Knob "B" to adjust the Electrode Contact Point. The electrode should be as close to the top of the wheel as possible.

After continuous grinding, you will begin to wear a groove in the wheel. Adjusting knob "B" moves the contact point down to a new spot on the wheel.

NOTE: Diamond Grinding wheels are specifically designed for grinding tungsten electrodes only!

SETTING THE TIP FLAT GAUGE:

With electrode extending to the desired length, tighten the electrode wand. Loosen Nut D on the Tip Flat Gauge and insert electrode into the Tip Flat Gauge.

Rotate Knob C until the Stop makes contact with the electrode tip, then lock in place with Nut D.

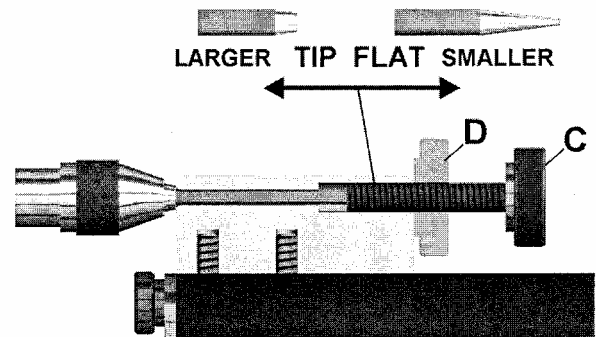

To duplicate electrode Tip Flat diameter, insert electrode into electrode wand. Extension should be beyond the desired final length.

Adjust electrode wand so there is a slight drag on the extended electrode. Insert electrode into Tip Flat Gauge and slide until the nose of the electrode wand contacts the Gauge face. Secure electrode into position by tightening the electrode wand.



1-800-944-2243
www.arc-zone.com

Piranha 2 Operations Manual: Page 6

GRINDING TECHNIQUES:

After the set up procedure, you are now ready to prepare precision ground tungsten electrodes quickly and easily.

Turn Power Switch On: Insert tungsten into the proper Collet Hole in the Universal Collet. Lightly contact the wheel with the tungsten and rotating the electrode in a steady manner until you achieve the desired Grind Angle or Tip-Flat. Be patient and Do Not gouge or force the electrode into the wheel by trying to grind the electrode too quickly. Gouging the electrode into the wheel causes excessive wheel wear and inconsistent electrode finish.

Approximate Electrode Grinding Time:

.040" (1.0mm)	5 to 10 seconds
1/16" (1.6mm)	10 to 15 seconds
3/32" (2.4mm)	20 to 30 seconds

REMOVING CONTAMINATED ELECTRODE TIPS:

Remove badly shaped or contaminated tips before regrinding. To do this, turn on the power and insert the tungsten into the proper sized hole on the Tip-Flat Block. Slowly push the tip against the wheel, rotating electrode until the point is removed. Do not force or gouge the electrode into the wheel.

If your tungsten electrode is so badly shaped that it won't fit into the proper sized hole on the Tip/Flat block, you will need to cut off the tip. Be sure to use the notching feature to avoid splintering in your electrode which could cause contamination in your weld.

ARC-ZONE.COM, Inc. • 2091 Las Palmas Drive Ste. C • Carlsbad, CA 92011-1551
Tel: 760.931.1500 • 800.944.2243 • Fax: 760.931.1504 • E-Mail: info@arc-zone.com
www.arc-zone.com

Copyright 2007, Arc-Zone.com®, Inc. All Rights Reserved

NOTCHING YOUR ELECTRODE

The notching feature is located at the right hand side of your unit. This feature is provided to notch your electrodes so they can be re-sized, or to remove the contaminated portion of a spent electrode.

Never snap your electrode without notching it first, as this will cause splintering which can result in contamination of your weld.

Insert your electrode through one of the two openings and push through so the electrode exits from the opposite opening. Hold both ends and push the electrode towards the corner of the rotating wheel.

Once you have notched enough of your electrode on one side, rotate the electrode to notch the other side.

Use the Tip/Flat Block to flatten the end of your electrode and proceed to grind as normal.



INSTALLING REPLACEMENT GRINDING WHEELS:

1. Turn power off and unplug the electrical outlet. Wait until the motor comes to a complete stop.
2. Unscrew and remove Knob "A" (see picture of adjusting knobs). Lift up and remove the Arm, taking care not to loose the washer between the Arm and the Knob. Set them aside.
3. Unscrew the Thumb Screws on the Wheel Cover. Remove the Wheel Cover to fully expose the wheel.
4. Using the supplied Allen Wrench, loosen the Wheel Mounting Screws.
5. Remove the old Wheel and mount the replacement Wheel on the Wheel Arbor.
6. Replace all of the other parts in reverse order used to remove them.



1-800-944-2243
www.arc-zone.com

Piranha 2 Operations Manual: Page 8

ORDERING REPLACEMENT WHEELS:

Replacement diamond wheels are available directly from Arc-Zone® and can be ordered online at: www.arc-zone.com, by phone: 1.800.944.2243, or fax your order to: 1.760.931.1504

Select the proper wheel using the wheel reference guide below.
Wheels are in stock for immediate delivery.

REPLACEMENT WHEEL GUIDE:

For optimum wheel life and surface finish when grinding .040" (1.0mm) through 3/32" (2.4mm) electrodes: Use a 300 Grit Diamond Wheel.

Medium-duty Replacement Wheel Price List:

Part No.	Description	Price
A-PTG-3-300 (699-001)	300-Grit Double-sided Precision Diamond Grinding Wheel: 3" (76.2mm) Diameter, for fine finish	\$146.91
A-PTG-3-150 (699-003)	150-Grit, Heavy-duty, Double-sided Diamond Grinding Wheel: 3" (76.2mm) Diameter	\$269.00

All prices are FOB Factory. Products listed above are stock items-consult factory for specialty wheels and accessories not listed.

Net-30 terms available O.A.C. for deliveries in the U.S. International orders by wire transfer.
Prices are listed are subject to change without notice.

Please see the parts diagram on the following page.

ARC-ZONE.COM, Inc. • 2091 Las Palmas Drive Ste. C • Carlsbad, CA 92011-1551
Tel: 760.931.1500 • 800.944.2243 • Fax: 760.931.1504 • E-Mail: info@arc-zone.com
www.arc-zone.com

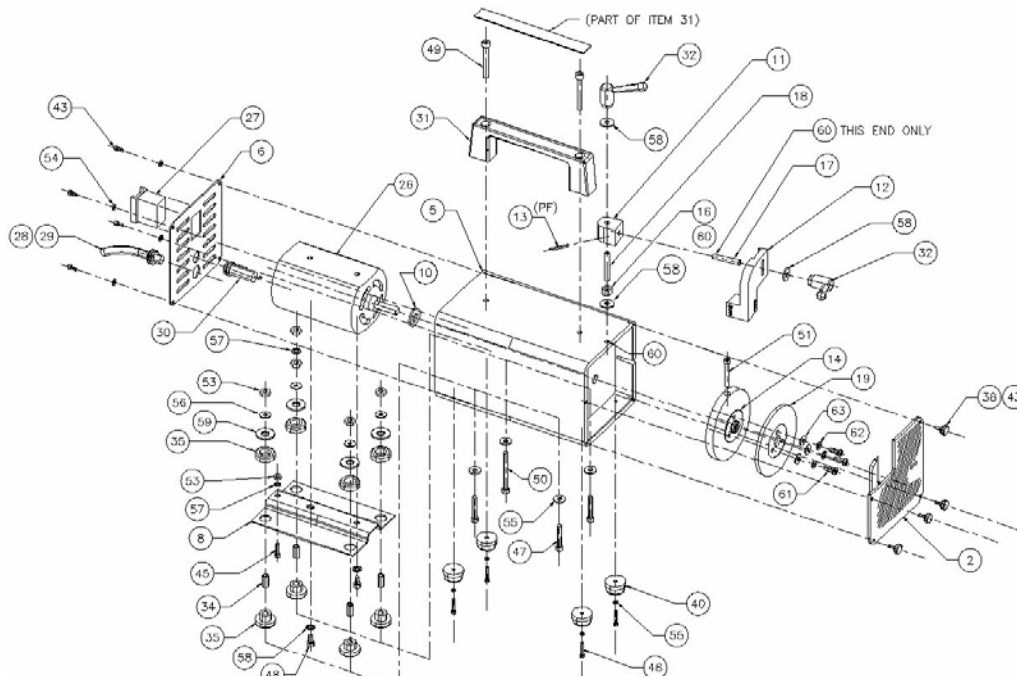

4	35	GROMMET RING
4	34	SPACER 1/4 X 1/2 X #6 ID CLEARANCE
2	32	HANDLE, ADJ., #10-32UNF (ID)
1	31	HANDLE
1	30	FUSE HOLDER, 125V / 3A FUSE
1	29	GROMMET, POWER CORD
1	28	POWER CORD WITH GROUNDED PLUG, 15A
1	27	POWER SWITCH
1	26	MOTOR
1	19	GRINDING WHEEL DISK, 3.15 OD
1	18	STUD, LONG, #10-32UNF
1	17	STUD, SHORT, #10-32UNF
1	16	COLLAR, #10-32UNF
1	14	DISK ARBOR
1	13	INDEX POINTER
1	12	ELECTRODE ARM
1	11	ARM PIVOT BLOCK
1	10	WASHER - FELT
1	8	MOTOR MOUNT CHANNEL
1	6	REAR COVER
1	5	HOUSING
1	2	WINDOW ASSY
-	1	TOP ASSEMBLY, PIRANHA II
QTY	ITEM	PART NAME

3	63	FLAT WASHER, #8
3	62	SPLIT LOCK WASHER, #8
3	61	BHCS, #8-32UNC X 1/2 LG
A/R	60	LOCTITE 420
4	59	FLAT WASHER, 5/16 ID X 1.00 OD X .05 THK
5	58	FLAT WASHER, #10
2	57	WASHER, TOOTHED LOCK, #6
4	56	FLAT WASHER, LARGE PATTERN, #6
4	55	FLAT WASHER, #6
4	55	FLAT WASHER, SMALL PATTERN, #6
4	54	FLAT WASHER, SMALL PATTERN, #4
6	53	HEX NUT, #6-32UNC
2	51	SHCS - ARBOR SET
1	50	SHCS, #6-32UNC X 1-1/4 LG
2	49	SHCS, #10-32UNF X 1-1/2 LG
2	48	SHCS, #10-32UNF X 1/4 LG
3	47	SHCS, #6-32UNC X 1.0 LG
4	46	SHCS, #6-32UNC X 1/2 LG
1	45	SHCS, #6-32UNC X 1/4 LG
8	43	SHCS, #4-40UNC X 5/16 LG
4	40	RUBBER FOOT
4	38	SHEAR-LOK THUMB SCREW KNOB, #4, BLACK
4	36	RIBBED BUSHING
QTY	ITEM	PART NAME



1-800-944-2243
www.arc-zone.com

Piranha 2 Operations Manual: Page 10

Arc-Zone® INTRODUCES:

State-the-Art Alloys in a New Non-Radioactive Tungsten!



All-Purpose Electrodes™

ArcTime™ All-Purpose™ Tungsten Electrodes

- State-of-the-art oxides scientifically formulated for balanced migration and evaporation rates guaranteed to extend electrode arctime.
- Increased number of arc starts before re-sharpening and fewer misfires.
- Increased productivity saving you money and time.
- Lower work function requires less energy to start than 2% Thoriated, runs cooler and lasts longer.
- Proprietary non-radioactive formulation.
- *FREE* Sample available upon request to qualified customers.
- *FREE* Guide to Selecting Tungsten.



ARC-ZONE.COM, Inc. • 2091 Las Palmas Drive Ste. C • Carlsbad, CA 92011-1551
Tel: 760.931.1500 • 800.944.2243 • Fax: 760.931.1504 • E-Mail: info@arc-zone.com
www.arc-zone.com

Copyright 2007, Arc-Zone.com®, Inc. All Rights Reserved