

Safety, Operations & Maint. Manual

Cleanfix® Scrubby



This unit is intended for commercial use

This manual is furnished with each new **Scrubby**. It provides necessary operation and maintenance instructions.

READ AND FOLLOW ALL INSTRUCTIONS, WARNINGS AND CAUTIONS BEFORE AND WHEN USING THIS SCRUBBER. THE MACHINE MAY ONLY BE USED BY PERSONS WHO HAVE BEEN INSTRUCTED IN ITS HANDLING AND EXPRESSLY ENTRUSTED WITH THE OPERATION THEREOF.

All information and specifications printed in this manual are current at the time of printing. However, because of Cleanfix's policy of continual product improvement, we reserve the right to make changes at any time without notice.

WHEN THE MACHINE IS DELIVERED

Congratulations on your excellent choice. The **Cleanfix Scrubby** is a light and easy to handle battery-powered machine for many different kinds of routine daily cleaning activities. The machine is useful for cleaning staircases, walls and other difficult to reach places.

This scrubber will afford you many years of trouble-free operating satisfaction, provided it is given proper care. All parts are passed rigid quality control standards prior to their being assembled to the finished product. Prior to packaging, your scrubber was again inspected for assurance of flawless assembly.

This scrubber is protectively packed to prevent damage in shipment. When the machine is delivered carefully check the carton for signs of damage.

Unpack the machine from the carton and inspect it for any possible damage.

Only a visual examination will reveal damage that may have occurred in transit. If damaged is discovered, immediately notify the transportation company that delivered your scrubber and request an inspection. As a shipper we are unable to report any claim for damage. You must origin any claim within 5 days of delivery. Be sure to keep the carton, packing inserts, packing list and carrier's receipt until the inspector has verified your claim. **CLEANFIX'S LIABILITY CEASES WHEN THE SHIPMENT IS PICKED UP BY THE CARRIER.** Cleanfix will furnish any information needed to expedite the claim process.

GENERAL PRECAUTIONS

FAILURE TO FOLLOW PRECAUTIONS AND WARNINGS MAY CAUSE SERIOUS INJURY TO THE OPERATOR AND CAUSE DAMAGE TO MACHINE, WHICH CAN VOID WARRANTY. TO REDUCE RISK OF FIRE, ELECTRIC SHOCK OR INJURY: READ ALL INSTRUCTIONS BEFORE AND WHEN USING THIS SCRUBBER.

WARNING

To Avoid Electric Shock, Do Not Expose to Rain. Store Indoors.

- This is **NOT** a toy. Close attention is necessary when used around or near children.
- Use only as described in this safety/operations manual. Use only manufacturer's recommended attachments and accessories.
- **Do not** use this scrubber with damaged cable. If the scrubber is not working as it should, because it has been dropped, damaged, left outdoors or dropped into water, contact authorized service center or factory.
- **Do not** handle the plug of the scrubber with wet hands.
- Store scrubber indoors in a dry area. **Do not** expose to freezing temperatures.
- **Do not** put any objects into openings. **Do not** use with any opening blocked; keep free of dust, lint, hair and anything that may reduce air flow.
- Keep hair, loose clothing, fingers and all parts of body away from openings and moving parts.
- Any manner of working that represents a safety hazard must be refrained from.
- **Do not** use where anesthetics or oxygen is used.
- Replace damaged or worn parts immediately with genuine original equipment parts to maintain safety and to protect your limited warranty.
- **Do not** pressure-wash the scrubber, as it may cause a short circuit, damage to components and/or operator injury.

CLEANING CHEMICALS AND HAZARDOUS DUST/LIQUID

- Attention must be paid to the manufacturer's safety instructions when using cleaning and care chemicals. Wear safety glasses and clothing if necessary.
- The danger of using easily flammable, toxic, health-damaging, caustic or irritating substances is expressly pointed out.
- Do not use the scrubber for surfaces that can release dust and liquids that are hazardous to health.

GENERAL SAFETY INSTRUCTIONS FOR BATTERY-OPERATED MACHINES

- **Observe** the safety and accident prevention regulations pertaining to the handling and installation of batteries.
- **Observe** the operating and handling instructions of the battery manufacturer.
- Before charging, check the battery cable and the charger cable and replace them if necessary.
- Smoking is **strictly prohibited** when charging batteries.
- Avoid open flames, flying sparks and glowing objects.
- Fire prevention equipment must be easy to access.
- Drinking and eating is **prohibited** in rooms where charging takes place.
- Wash hands thoroughly immediately after working on the batteries.
- **Risk of short circuit or fire! Do not** place metal objects on the batteries.

CARE OF SCRUBBER

This scrubber is designed to be safe when used to perform cleaning functions as specified. Should damage occur to electrical parts, the unit should **NOT** be used until the damage is repaired by the manufacturer of an authorized service center. This will avoid further damage to the scrubber or injury to the user.

These instructions are for your protection and information.

PLEASE READ CAREFULLY! Failure to follow instructions or precautions could result in injury or damage to the user and/or the scrubber.

SAVE THESE INSTRUCTIONS!

PARTS & ACCESSORIES

- The disk connected to the motor and the on/off switch on the handle of the plastic molding are standard
- Reversible telescope handle, including the adjustable grip.
- Battery, NiCd 9,6 V 1900 mAh.
- Quick battery charger 120 V
- Nylon brush (several models, different degrees of coarseness, suitable for several purposes, available)
- Nylon pads (different degrees of coarseness available)
- Microfiber pad
- Solution dispenser.

BEFORE USING THE SCRUBBER

1. Check that voltage of power source is the same as battery charger. (120 V)
2. Charging of the battery is only permitted in dry areas.
3. Put the plug of the charger in the wall socket and place battery in the charger.
4. Use only battery chargers which are approved by your dealer.
5. When the green light shows, battery is charged and is ready for use.
6. Remove battery from charger and insert into the special opening of the machine head.
7. Press battery firmly down till bottom. The catches on the battery take care of bringing the battery into the right position inside the machine.
8. Place the brush with nipples up in the holes of the drive disk on the bottom of the motor.
9. If the nylon brush loses its shape it can be straightened by immersing the brush in hot water for 30 seconds. The brush will regain its original shape.
10. Working with pads, they should be placed as central as possible on the driving disk and directly attached to the Velcro.
11. The right working position, depending on the job, will be obtained by fixing the telescope handle on the correct length, using the plastic turn lock.
12. Use the screw buttons, to fix the adjustable handle in the preferred position.
13. Check that the machine is in proper condition.
14. Remove obstacles, such as furniture etc. from the area to be cleaned. Large pieces can be removed to opposite end of the room from where you start cleaning.
15. All covers, hoods and lids must be correctly attached and closed. Make sure all switches are in the OFF position.

Reversible telescopic handle

16. Place the telescopic handle in the opening of the handle at the motor part and press firmly until the fixing button on the connector comes up. Tighten the fixing bolt on the iron support slightly.
17. Before removing the handle, first loosen the fixing bolt on the iron support slightly. Push the button on the connector of the handle and pull to remove while holding the button.

DURING OPERATION

With telescopic handle, when right handed:

- Take the adjustable grip into the left hand.
- Take the top handle with on/off switch in the right hand.
- Pull the trigger switch and keep this pulled during use. After the switch is released, motor stops instantly.

As hand held unit without the telescopic handle.

- Take the motor part by the plastic grip on top in the right hand.
- The motor part of the **Cleanfix Scrubby** has a standard safety lock on top of the grip, which blocks the use of trigger switch.
- Push the safety lock with your thumb forward, before using the trigger switch. When motor is running the safety lock can be released.
- The motor starts running as soon as the trigger switch has been pulled. If the trigger switch is continuously pulled it keeps the motor running. After the switch is released, the motor stops instantly.

AFTER USING THE SCRUBBER

- Remove brush or pad from the machine and clean thoroughly.
- Brush to be stored with bristle up to avoid damage to brush shape.

INSTRUCTIONS FOR BATTERIES

When battery is low

- Remove the battery from your **Cleanfix Scrubby** by pressing on the tabs on both sides of the battery and pulling the battery out of the motor part.
- Plug the quick battery charger into the wall socket. The indicator light is green.
- Place battery into charger. The red light indicates charging.
- If you have trouble getting a red light for charging, insert battery to the charger and remove again within 15 seconds.
- This resets the safety zone on the battery.

Safety instructions for battery and machine

- **Never use charger in wet or moist environments!**
- Prevent damage to electric cables, caused by sharp edges or objects. In case the power cable is damaged, charger should be taken to an authorized repair shop by manufacturer. Changing cables require special tools and spare parts.
- Never destroy worn-out batteries by burning. They may explode!
- In case liquid from battery contacts skin, proceed as following:
 1. Wash the contacted skin with water and soap
 2. Neutralize the battery liquid with vinegar or juice of lemon (acid)
 3. If battery liquid contacts the eyes, at one rinse eyes with clean water for at least 10 minutes.
 4. Contact a doctor immediately.
- Only carry out work on batteries according to battery manufacturer's instructions.
- Wear safety glasses and clothing when working on batteries.
- Observe the accident prevention rules and regulations.
- Smoking is strictly prohibited.
- Keep battery away from open flames, glowing objects and sparks, otherwise there is a danger of explosion and fire.
- Immediately rinse any acid splashed into eyes or onto skin out or off with plenty of clean water. Then immediately consult a doctor.
- Wash out clothing contaminated with acid with water.
- Avoid short circuits! Explosion and fire hazard!

INSTRUCTIONS FOR BATTERIES (cont.)

- **WARNING!** Metal parts in the battery cells are always live. Therefore, do not put/store objects or tools on the battery.
- Electrolyte is extremely caustic. Contact with the electrolyte is not possible during normal operation.
- In the event of destruction of the casing of batteries, the bound electrolyte released is just as caustic as the liquid electrolyte.
- Batteries filled with acid must not be handled by children.
- Use only approved lifting and transport equipment.
- Lifting hooks must not cause damage to cells, connectors or connection cords/cables

Charging

WARNING!

Only use chargers approved by Cleanfix for charging.

Attention! Worn-out batteries can damage environment, should be taken to a centre for hazardous waste disposal and not mixed to normal refuse collections and disposal.

Under extreme circumstances, little liquid might extend from battery. This does not necessarily indicate failure or damage.

Care

- The battery is to be kept clean and dry at all times in order to avoid leak currents and sparking.
- For cleaning, remove batteries, wear safety glasses and protective clothing. Select the place of installation so that dirty water produced during cleaning is channeled to a suitable waste water treatment plant.
- The cell plugs must not be unscrewed.
- The plastic parts of the batteries may only be cleaned with water or cleaning cloths soaked in water without additives. After cleaning, the surface of the batteries is to be dried (compressed air, cleaning cloth).

Storage

- If batteries are taken out of service for any length of time, they are to be stored fully charged in a frost-free room.
- Due to the batteries' spontaneous discharging, recharging needs to be done at regular intervals.

Faults

If faults are found, the customer service staff must be informed promptly.

Disposal

Old batteries showing recycling symbols are re-usable commercial goods and must be channeled to the recycling process.

All other batteries are to be disposed of as hazardous waste in accordance with existing regulations.

Warranty

Failure to comply with the operating & handling instructions, carrying out repairs using non-original spare parts and attempts to carry out the repairs by the user lead to a loss of the right to make claims under the warranty.

MAINTENANCE AND REPAIR

- Only do maintenance work described in this manual.
- Always use original spare parts.
- **WARNING!** Do not make any technical alterations to scrubber. This can put your safety at risk and will cease the warranty.
- Always contact authorized service center or factory for other maintenance and repair work.

OTHER WARNINGS

WARNING

Service and repairs should only be performed by an authorized service center.

- Though the **Cleanfix Scrubby** is protected against penetration of liquid, only driving disk and not motor nor battery are allowed to get into contact with water.
- The **Cleanfix Scrubby** has a splashguard. Depending on the job however, wearing eye and face protection are recommended to protect against direct contact with cleaning agents during operation.
- Working on stairs or platforms, observe all appropriate safety regulations. Consider torque caused by machine.
- Ensure that loose clothing or other material does not become entangled in rotating parts of the **Cleanfix Scrubby**.

TECHNICAL INFORMATION

- Battery 9,6 V NiCd 1900 mAh
- Quick battery charger 120 V – charging time 60 minutes
- Operational time with single battery, aprox. 1,5 hr
- Drive disk / brush speed 350 rpm
- Brush body and bristle made of nylon
- Drive disk fits 6 to 6.5 inches pads.
- **Cleanfix Scrubby**, including battery, weights 6 lbs. only
- Battery, quick battery charger and **Cleanfix Scrubby** have CE approval.

New Machine Warranty



1. Limited Warranty. These terms and conditions of the New Machine Warranty are a material part of the agreement between Buyer and Cleanfix Cleaning Systems Inc., a New Jersey-based corporation (hereinafter "Cleanfix"), and supersede warranty terms and conditions in documentation submitted by Buyer to Cleanfix. Cleanfix warrants new machines of its manufacture against defects in material and workmanship under normal use and service to the original end-user purchaser. No person, agent, representative or distributor is authorized to give any warranties on behalf of Cleanfix, or to assume any other liability for Cleanfix in connection with any Cleanfix machine. Cleanfix reserves the right to make changes to its equipment without notice. The warranty coverage is subject to the conditions below.

2. Registration of Warranty. The warranty commences on the date of purchase by the original end-user from an authorized Cleanfix distributor or agent, subject to proof of purchase. The warranty commences latest, however, after six (6) months of the purchase date by the authorized distributor or agent of Cleanfix. Any new Cleanfix machine must be registered immediately with Cleanfix by the original end-user customer by fully completing and returning the warranty registration form to Cleanfix. If proof of purchase cannot be identified through a completed and returned warranty registration form, the warranty commences from the date of sale to the authorized Cleanfix distributor.

3. Warranty Coverage. Subject to conditions outlined below, Cleanfix warrants rotationally molded PE housings and tanks on all of its machines to be free from defects in material and workmanship, under normal use and service for ten (10) years to the original end-user.

Subject to conditions outlined below, Cleanfix warrants fiberglass housings and tanks on all of its machines to be free from defects in material and workmanship, under normal use and service for three (3) years to the original end-user.

Under this warranty Cleanfix warrants the performance of non-polyethylene and non-fiberglass components to be free from defects and workmanship for up to one (1) year to the original end-user. Parts replaced or repaired under this warranty are warranted for the remainder of the original warranty period. (See table below)

Rotationally molded PE housings and tanks	10 years
Fiberglass housings and tanks	3 years
Vacuum motors, brush motors, pump motors, boards and electronics	1 year
Battery and battery charger*	1 year

* The 1 year period warranty commences with the purchase date by the authorized distributor or agent of Cleanfix.

Service labor charges are covered for up to one (1) year from the date of purchase through an authorized Cleanfix service provider. A total maximum of one (1) hour travel time - equal to one (1) hour labor rate - is covered for large machines, namely Falcon, Raven, Eagle and larger for 90 days. No coverage is extended for diagnosis time.

4. Product Exceptions and Exclusions. ALL vacuum cleaners and air movers are warranted for one (1) year. No warranty is extended for wear items, accessories and attachments including, but not limited to, belts, brushes, pad holders, capacitors, carbon brushes, wheels, casters, glides, clutches, cords, filters, filter bags, gaskets, hoses, rectifiers, switches, float switches, valves, squeegees, bearings, pulleys, relays, actuating cables, wheels, tires, vacuum cleaner attachments.

The purchaser is assured that meticulous care has been exercised in the selection, assembling and testing of these parts and components before shipping. No warranty is extended for machine finish, labels and other cosmetic parts or features.

5. Stated Warranties. Stated warranties are in lieu of all other warranties, expressed or implied. Any statutory implied warranties, including any warranty of merchantability or fitness for a particular purpose, are expressly limited to the duration of the written warranty. Cleanfix will not be liable for any other damages, including but not limited to incidental, indirect or special consequential damages arising out of or in connection with the furnishing, performance, use or inability to use the machine, including damages to persons or property. This remedy shall be the exclusive remedy of the buyer. The warranty is limited to the warranty.

6. Warranty is null and void for the following.

- Damage, defects, malfunction or other failures caused by not using the electric current indicated on the spec plate, including the use of improper extension cords.
- Damage or defect caused by accident, misuse, neglect, abuse, fire etc., including use of incompatible or corrosive chemicals or overloading of capacity.
- Failure caused by lack of proper maintenance and care, including proper machine clean-up after use, proper charging procedures for batteries.
- Failure caused by loss, damage or removal of protective components, including, but not limited to, filters and filter screens, tank covers and lids, skirts and bumpers, float shut-off assemblies.
- Freezing of any water or chemical related components (this will void all warranties on water or chemical related components, internal or external, of the product).
- Deposits and buildup in any water or chemical related systems due to hardness in water (this will void all warranties on affected systems).
- Any design alterations, adjustments and/or repairs performed on the equipment by an organization not authorized or specified by Cleanfix.
- Use of any parts not approved by Cleanfix, including, but not limited to, batteries, battery charger, filter bags, belts, electric components, motors.
- Use of machine for a purpose other than which it was designed and intended, and use of machine in excess of design duration.
- Damage in transit.

7. Warranty Claim Procedure. If a difficulty develops during the specified warranty period, contact the authorized Cleanfix distributor/partner from whom the machine was originally purchased. Do not return any products to Cleanfix unless explicitly authorized by Cleanfix. Cleanfix may elect to require the return of the machine or component(s) to validate the claim. Any defective machine or component to be returned must be shipped freight pre-paid to an authorized Cleanfix distributor/service center.

Cleanfix will provide and charge for replacement parts, including shipping and handling, to the original purchaser through an authorized service center. If the part is returned within 30 days and is found defective, the purchaser will be credited for the cost of the replacement part including shipping and handling.

8. Term. This warranty is valid for all products sold after January 1, 2006. A product sold before that date will be covered by the limited warranty in effect at the date of sale to the original purchaser.

Parts List

Cleanfix® Scrubby

This unit is intended for commercial use

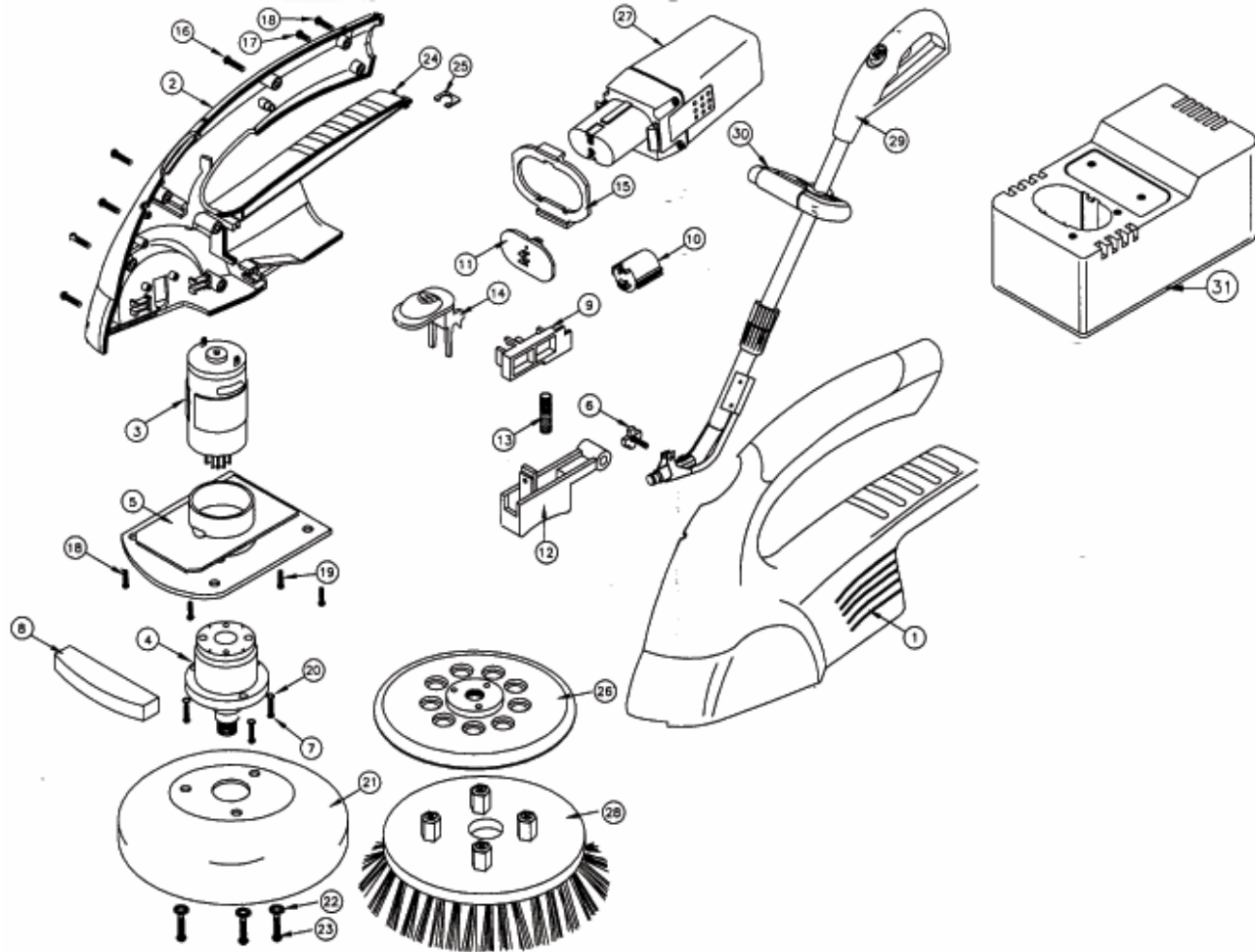

Item#	Part#	Description
1	185.001	Support housing
2	185.002	Cover housing
3	185.003	Johnson DC motor HG583-LG-63738
4	185.004	Gear box assy.
5	185.005	Gear box bracket
6	185.006	Cross screw knob
7	185.007	M/C screw
8	185.008	Foam rubber
9	185.009	On/Off slide switch
10	185.010	Contact plate holder (for handle)
11	185.011	Contact plate holder (battery)
12	185.012	On/Off switch knob
13	185.013	Spring (for on/off switch)
14	185.014	Safety switch knob
15	185.015	Power pack guiding plate

Item#	Part#	Description
16	185.016	S/T screw 3.5x18
17	185.017	S/T screw 3.5x10
18	185.018	S/T screw 3.5x12
19	185.019	Screw
20	185.020	Spring washer M3.0
21	185.021	Brush cover
22	185.022	Overlapping toothed lock washer
23	185.023	MC screw 5x10
24	185.024	S/T screw 2.0x10
25	185.025	U-shape clip
26	185.026	Rubber backing pad assy.
27	B-2AHNI	Standard Battery, 1,9 AhNi-Cd
28	185.059	#Scrub brush standard, nylon, 6"
29	185.029	Handle bar assy.
30	185.030	Additional handle assy.
31	BCH-1SCR	Battery quick charger for Scrubby

Version March 2007

All information and specifications printed in this parts list are current at the time of printing. However, because of Cleanfix's policy of continual product improvement, we reserve the right to make changes at any time without notice.

Copyright ©2007 by Cleanfix Cleaning Systems, Inc., 465 West Main St., Wyckoff, NJ 07481.
All rights reserved. Content is subject to change.