

Welcome to warmup

4iE Smart WiFi Thermostat operating guide
See reverse for installation guide



Introduction

The 4iE default screen is the home screen. Pressing the temperature figure in the centre of the screen allows you to override it. Pressing the menu button allows you to start programming and setting up the 4iE. You'll often find a help button on pages with several options to give more information.

If you do not press any button for 1 minute, the 4iE screen will dim and revert to the home screen. To wake the 4iE just tap the screen or press **Wake**.

The icons at the bottom of the screen are your WarmApps. These can be set up on MyWarmup to show traffic and journey alerts, along with your energy saving advice

To turn the thermostat on or off, press the power button on the bottom of the device for 3 seconds.

MyWarmup

You can also program and set-up your 4iE with your tablet or computer by visiting my.warmup.com.

If you use a smartphone to access MyWarmup, you will be shown a mobile version which gives quick access to important features like **Smart Overrides**. If you want to set up your 4iE using a smartphone you will have to ensure you access the desktop version of the website. This can be changed in the browser settings of your phone or by clicking the link at the bottom of the mobile page.





Getting Started

On initial power up the 4iE will ask you to connect to a WiFi network. Once connected you will be asked to create a **MyWarmup** account. If you skip the WiFi connection stage, you will be guided through an offline setup procedure (with the options shown below) and can set up a MyWarmup account at a later date.

- Language
- Internet Settings
- Time
- Date
- Daylight Savings
- Heating type
- Temperature Display
- Theme
- Brightness
- Audio Feedback
- Floor type
- Heating control type
- Heating Program Schedule
- Energy Monitor settings

Important!

Ensure you choose the correct **System Type**: Electric (underfloor), Hydronic (underfloor) or Conventional (central heating with radiators).



Connecting to MyWarmup

Once your 4iE is powered up, you need to create your MyWarmup account. Navigate your web browser to my.warmup.com

Enter your email address and create a password for your account. You will be sent a confirmation email when your account is set up. Make sure you check your spam folder as well as your inbox.

When you've received your account activation email, you can connect your 4iE to the account. Ensure your 4iE is connected to the internet. If you see an error icon on the homescreen (see below), then your thermostat is not connected to the internet.

If you cannot connect to the internet, you may skip this stage and connect at a later date.



If you see these icons, call Warmup for 24/7/365 assistance on **0845 345 2288**

When your 4iE is connected to the internet, just enter the unique codes displayed on the connection screen into **MyWarmup**. Your 4iE will then be connected.



Set your heating program

With your 4iE, you can choose to set a custom heating schedule, fixed temperature or a preset program designed for different rooms.

To adjust the program, you must highlight the days that you want to program by pressing them, then press **Program**. You can select multiple days in any combination, such as weekdays only, to program separate weekday and weekend temperatures. To do this, program all the weekdays at once and then program the weekend when you're finished.

The programming works by setting Comfort Periods of warm temperatures, shown with a green line. Any time not covered by a Comfort Period will use a lower Setback temperature to save energy. The default setback temperature is 16°C and you can change this once you've set up your program if needed.

You can add up to 5 Comfort Periods per day and when you've set what you want, just press **Done**. You'll see the summary of your program which you can edit by repeating the steps above, or just press **Accept** to set your program.

Remember: The 4iE can also learn your schedule and program itself. To activate this, set it into Learning Mode on MyWarmup

Preset Programs

You can select a preset program schedule to get you started. You can edit the program whenever you like by following the steps in [Set Your Heating Program](#)

Below is a summary of the Preset Programs

	Bathroom		Kitchen		Bedroom		Living Room	
	Time	Temp	Time	Temp	Time	Temp	Time	Temp
Mon-Fri	06:00	25	06:00	23	06:00	25		
	08:00	10	08:00	10	08:00	10		
	19:00	20	18:00	23	20:00	20	18:00	23
	23:00	15	22:00	10	23:00	10	21:30	10
Sat-Sun	07:00	25	07:00	23	06:00	25		
	11:00	18	11:00	18	08:00	10	08:00	23
	18:00	20	18:00	23	20:00	20	18:00	20
	23:00	15	22:00	10	23:00	10	20:00	10

Holiday Mode

Holiday Mode allows you to override your schedule with a fixed temperature over a number of days. This helps you save energy when you know you'll be away for a while by setting a lower temperature. **Holiday Mode** can be found in the **Program** menu

Just set the start and end times of your holiday, or leave the end time as **Unspecified**, if you want **Holiday Mode** to run indefinitely. Then set the temperature you want when you're away.

Gradual Start

Gradual Start allows you to bring your floor up to temperature slowly, which is required for some floor finishes such as solid wood, and can also be found in the **Program** menu.

Enter the maximum temperature and the time required to reach that temperature to set **Gradual Start**. Different floors have different requirements so please contact your floor installer or supplier for advice on how to set **Gradual Start** correctly.

Frost Protect

Select **Frost Protect** mode to set your heating to 5°C. This will help protect your home from frost and will run continuously until you raise the temperature again.



Energy Monitor

The **4iE** learns how you use your system and how your house reacts to the heating and weather. It can give you an estimate of your energy usage and the running cost of your system.

You will need to enter the power of your system, and in some cases, the efficiency. If you do not know these, speak to your installer or go to www.warmup.co.uk and use our online **Heat Requirement Calculator**.

You will also need to enter the cost of your energy, in order to calculate the running cost of your system. Press **Energy Settings**, and select if you have a single rate tariff or a standard/low energy tariff (where you have a discounted cost during part of the day). Enter your cost per KWH and relevant currency and, if required, the time the low energy tariff starts and stops and the discounted cost during that time.

When you've set up the **Energy Monitor** you can view the estimated usage or cost over a selected time period. If you have a standard/low energy tariff, the amount and cost of energy used during the standard period will be displayed in dark green and the amount used in the low period will be displayed in light green

Settings

The 4iE can be configured in different ways to suit you. The functions that can be accessed in the Settings menu include:

Time

- Set time manually set time (only available without WiFi connection)
- Set date manually set date (only available without WiFi connection)
- Daylight savings set daylight savings (only available without WiFi connection)

Heating preferences

- Temperature format choose celsius or fahrenheit
- Control air/floor use air or floor sensor as main measurement
- Adaptive learning starts heating early so it's up to temperature at the right time

Display/Audio

- Background change the screen background (upload your own on MyWarmup)
- Home screen style choose a theme for the main screen
- Display brightness change the screen brightness for normal use and standby
- Lock set a lock code and limits for when the lock is active
- Audio Feedback turn the 'click' sound on or off

Network

- Choose a WiFi network and enter the password if required

Advanced settings

These options can affect the performance of your thermostat and should only be modified by an experienced professional or under the instruction of Warmup Technical Support

Heater settings

Heater limits Set the temperature limits for your floor type. **User Defined** lets you set custom limits

Regulator

Regulator mode controls the heating in 10 minute cycles. The number you enter is the number of minutes in every 10 minute cycle that the heating will be on. This mode will not use the floor or air sensors for measurement

Fil Pilote

This is a feature specifically for France. You must also connect Fil Pilote to terminal 1

Master/Relay

This allows one thermostat to control another

1. Choose which thermostat is Master and which is Relay
2. Use low voltage cable to connect terminal 6 of both thermostats
3. Use low voltage cable to connect terminal 7 of both thermostats (in addition to floor sensor cables on the Master thermostat)
4. Set Relay thermostat to Relay mode first, then set the Master thermostat to Master mode
5. Program the Master thermostat. The Relay thermostat will no longer use its sensors, it will follow the Master thermostat

Gradual Start

Set the maximum temperature and time required to reach that temperature
Set the specification of the probes. You can also choose to hide the error message if you do not want to connect a probe

Probes

Probe application

Choose if the floor probe is being used as a Floor or Amb (ambient) sensor

Offset

Set the offset of the sensors to improve accuracy

Reset

This will restore all the factory default settings. You can also hold the button on the rear of the front module for 10 seconds to perform a system reset

Electric Underfloor Installation

see numbering on diagram below

2. Connect to Power Supply (Live – MAX 240V)
3. Connect to Power Supply (Neutral – MAX 240V)
4. Connect to Warmup heater(s) (Neutral – MAX 3600W/ 16 Amps)
5. Connect to Warmup heater(s) (Live – MAX 3600W/ 16 Amps)
7. Connect to 1st wire of floor sensor (colour not important)
8. Connect to 2nd wire of floor sensor (colour not important)

Hydronic Underfloor Installation

see numbering on diagram below

2. Connect to Power Supply (Live – MAX 240V)
3. Connect to Power Supply (Neutral – MAX 240V)
4. Connect to wiring centre (Neutral if present – MAX 3600W/ 16 Amps)
5. Connect to wiring centre (Switch Live – MAX 3600W/ 16 Amps)
7. Connect to 1st wire of floor sensor (colour not important)
8. Connect to 2nd wire of floor sensor (colour not important)

Central heating Installation

see numbering on diagram below

2. Connect to Power Supply (Live – MAX 240V)
3. Connect to Power Supply (Neutral – MAX 240V)
4. Connect to Boiler circuit (Neutral if present – MAX 3600W/ 16 Amps)
5. Connect to Boiler circuit (240V Switch Live – MAX 3600W/ 16 Amps)

For extra low voltage or volt-free systems a contactor must be used. Contact Warmup for more details.

Connecting the 4iE directly to extra low voltage or volt-free boilers may cause damage to the boiler circuit.

Special Installation

see numbering on diagram below

- Second sensor installation: (2nd floor probe or exterior probe)**
6. Connect to 1st wire of external sensor/ 2nd floor sensor
 7. Connect to 2nd wire of external sensor/ 2nd floor sensor

Master/Relay installation: (connecting 2 stats together)

6. Connect to terminal 6 on other thermostat
7. Connect to terminal 7 on other thermostat

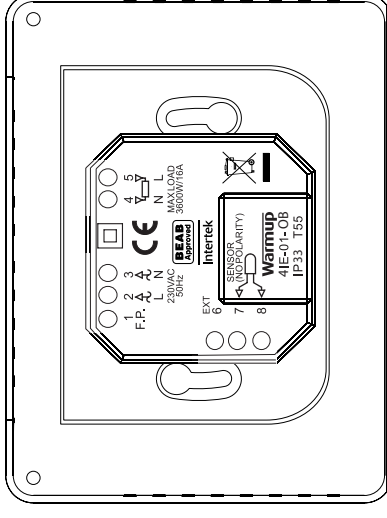

Mounting Thermostat

1. Push excess wire back through the wall box and insert thermostat back module into wall box.
2. Put fixing screws through mounting holes and tighten.
3. Ensure that thermostat is straight before tightening completely.
4. Replace thermostat front housing:
 - i) align and sit front housing on to hinges,
 - ii) push lower half of front housing until a 'click' is heard.
5. Ensure front housing is securely fixed.
6. **IMPORTANT:** Tighten both retaining screws

Powering Up

You can now power up the thermostat and begin the programming process. An easy to follow menu will guide you through the rest. If you want to turn on / off the thermostat and heating system then hold down the recessed button on the bottom of the stat for 3 seconds

Error Messages

Your thermostat can give you two error indications:

1. "er1": This will occur if no floor sensor is detected
2. "er2": This will occur if the floor sensor has a short circuit

Introduction

The 4IE thermostat is designed to aid in the comfort of your home by providing timed regulation of your heating system. The thermostat is designed to receive temperature input signals from the following sensors:

1. Air sensor located inside thermostat
2. Floor sensor installed in floor if using underfloor heating (see Warmup heater instructions for details)
3. Optional 2nd sensor

The thermostat is not a safety device. In order to avoid damaging your system the correct system and floor type should be selected during the thermostat programming process.

Electrical Specification:

- Supply voltage: 230V +/-15% at 50Hz
- Thermostat is not designed for use with intermittent power supply.
- Maximum Switch Load: 16A resistive
- Insulation Class : II
- Housing : IP33
- Standards: EN60730-1 & EN60730-2-9 standards

WARNING – Important safety note

This product uses mains voltage electricity and work should only be carried out by a qualified electrician. You should always isolate the power supply before attempting to install or repair the 4IE thermostat. The thermostat should not be put into operation unless you are certain that the entire heating installation complies with current general safety requirements for electrical installations. Electrical installation to be in accordance with latest IEE Wiring Regulations and appropriate Statutory Regulations.

Location

The thermostat should be installed inside a single gang electrical wall box that is at least 30mm deep. For optimal performance the thermostat should be located in an area with good ventilation. It should not be beside a drafty window/ door, in direct sunlight or above another heat generating device (e.g. radiator or TV).

The thermostat is designed for operation between 0°C and 55°C with relative humidity less than 80%.

Installation

Separate the front housing of thermostat from wall module.

1. Unscrew both closing screws (bottom of stat) until they will not turn any further.
2. Release front housing by gripping lower half of outer frame and pulling outwards then upwards
3. Place front housing somewhere safe
4. Run all wires to the wall box. Check to ensure that you have included the following:
 - Power (Live and Neutral)
 - Heater (Live and Neutral or Switch Live only)
 - Floor sensor
 - Fill pilot (if necessary)
 - External / 2nd floor sensor (if necessary)
5. Pull wires through wall box and complete terminal wiring.

IMPORTANT: Ensure that multi-stranded wires are fully inserted into the terminals and secured tightly. Any loose strands should be trimmed as they could cause a short-circuit.

If connecting more than two heaters, an electrical junction box will be required.

NOTE: Always ensure that the sensor cable is installed in a separate conduit to the power cables supplying the thermostat and heating system.

Warmup

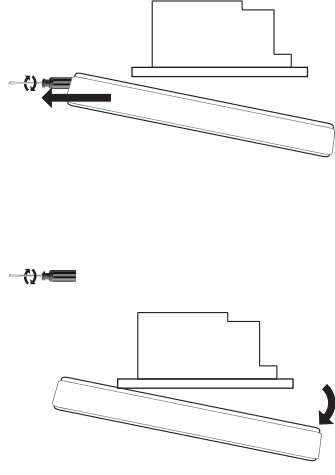
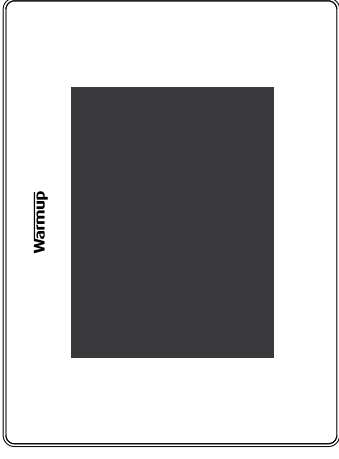

Contact Us

UK

0845 345 2288

702 & 704 Tudor Estate
Abbey Road
Park Royal
London
NW10 7UW

Warranty

Warmup plc warrants this product, to be free from defects in the workmanship or materials, under normal use and service, for a period of three (3) years from the date of purchase by the consumer. If at any time during the warranty period the product is determined to be defective, Warmup shall repair or replace it, at Warmup's option, if the product is defective, please either:

(i) return it, with a bill of sale or other dated proof of purchase, to the place from which you purchased it, or

(ii) contact Warmup. Warmup will determine whether the product should be returned, or replaced.

This warranty does not cover removal or reinstallation costs, and shall not apply if it is shown by Warmup that the defect or malfunction was caused by failure to follow the instruction manuals, incorrect installation or damage which occurred while the product was in the possession of a consumer.

Warmup's sole responsibility shall be to repair or replace the product within the terms stated above.

WARMUP SHALL NOT BE LIABLE FOR ANY LOSS OR DAMAGE OF ANY KIND, INCLUDING ANY INCIDENTAL OR CONSEQUENTIAL DAMAGES RESULTING, DIRECTLY OR INDIRECTLY, FROM ANY BREACH OF ANY WARRANTY, EXPRESS OR IMPLIED, OR ANY OTHER FAILURE OF THIS PRODUCT. THIS WARRANTY IS THE ONLY EXPRESS WARRANTY WARMUP MAKES ON THIS PRODUCT. THE DURATION OF ANY IMPLIED WARRANTIES, INCLUDING THE WARRANTIES OF MERCHANTABILITY AND FITNESS FOR A PARTICULAR PURPOSE, IS HEREBY LIMITED TO THE THREE-YEAR DURATION OF THIS WARRANTY.

This Warranty does not affect your statutory rights.

Lifetime warranty also available. Contact Warmup or visit www.warmup.co.uk for details