

CXX Series

User Manual

Teleste Corporation



CXE880
Fibre node

Contents

Introduction	3
Installation	3
Housing.....	3
Powering.....	3
Status monitoring card (optional).....	4
Interfaces.....	5
Fibre installation.....	5
Front panel.....	7
Features	8
Forward path / Optical receiver.....	8
Return path / Optical transmitters.....	11
Legal declarations	12

Introduction

The CXE880 is a fibre deep optical node with high performance characteristics. It is designed for cases where high performance and cost effectiveness are a demand. Requirements of future networks, like 1 GHz frequency band and 85/108 MHz return split are taken in account. The node is based on fixed receiver and transmitter.

The use of an integrated optical receiver and transmitter eliminates time-consuming mounting of connectors and fibre splicing inside the housing. The optical receiver supports light wavelengths from 1290 nm to 1600 nm.

Alignment of this product is made easy and no external plugs are needed. Fibre connectors are situated at the housing wall, enabling quick installation. The OLC (Optical Level Control) as well as gain and slope adjustments use electrical controls that improve the reliability of the node.

Optional status monitoring card is factory installed and transmits status information using 10.7 MHz data link to e.g. HDO203 data receiver. Data link works with up to 32 combined CXE880 return path signals.

Installation

Housing

The fibre optic receiver can be installed either into a street cabinet or to a sheltered outdoor environment. **Note:** Fibre adapter is not waterproof. The amplifier should be installed in a vertical position so that the external cable connectors are underneath. At least 100 mm of free space should be left above the amplifier to ensure sufficient cooling air circulation.

The cover of the housing is closed by a single bolt. Tighten the bolt with a 4 mm Allen key. Final tightening torque should be 2.5...3.5 Nm. Before closing the lid ensure that:

- nothing is trapped between the lid and the case
- all case gaskets are in their correct positions
- lid seats evenly on the rubber gasket

The class of enclosure is IP43 when correctly installed and tightened. To ground the amplifier housing connect at least 4 mm² grounding wire (Cu) from a proper earth to the grounding point

Powering

The supply voltage of the remote powered amplifier (26...65 V AC or \pm 30...90 V DC) can be fed through the RF output port (Figure 4 pos. 9). Make sure the remote powering jumper (Figure 4 pos. 12) is in correct position for remote powering. Refer to Figure 4. External power can also be fed through the amplifier into the network by moving remote powering jumper to "ON" position. Maximum feed-through current is 2 A.

The power intake of the remote powered amplifier may also be done externally via the cable feed-through that is located on the upper right corner of the amplifier (see Figure 1). The protective fuse is located on the left hand side of the power supply board.

8907016

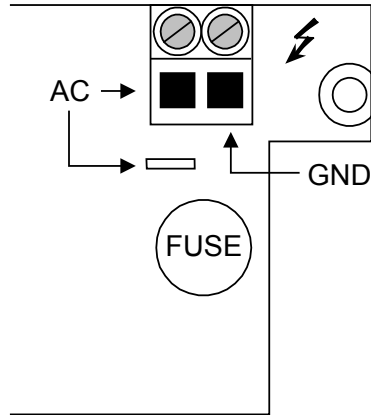

Figure 1. Remote cable connector

The locally powered CXE880 fibre node is connected to the main voltage of 165...255 V AC via its own power cord. The power supply is double shielded and does not require separate grounding. However, the amplifier housing has to be grounded from the grounding point. The supply voltage fuse (T3.15 A / 250 V) is located on the upper right corner of the amplifier, underneath the remote cable connector (Figure 1).

Status monitoring card (optional)

When equipped with an optional status monitoring card the node continuously monitors internal temperature, local and remote supply voltages, optical input power, laser current, lid status and statistics of power failures. Measurement results and status information is transmitted using 10.7 MHz FSK data link to e.g. HDO203 data receiver. The two first mentioned parameter statuses are also indicated with the LED indicator (Figure 4 pos. 17). The following table further describes behaviour of the LED. During the power-up sequence the LED will display yellow light for a short period of time to indicate that the LED is functional. The LED blinking indicates that packets are sent on the FSK link.

Status monitoring LED on CXE880	Description
Green	No alarms
Yellow	Internal temperature exceeds 75 °C or local supply voltage is not between 11...13 V.
Red	Internal error in status monitoring card. Does not affect node operation.

For more information on data sent on FSK link and its representation, see HDO230 user manual.

Interfaces

Underneath the CXE880 fibre receiver are two optical fibre ports with fibre adapters and one RF output port with F-female connector. The coaxial output has a standard PG11 thread and they accept any KDC type adapter or connector. The length of centre conductor is illustrated in Figure 3.

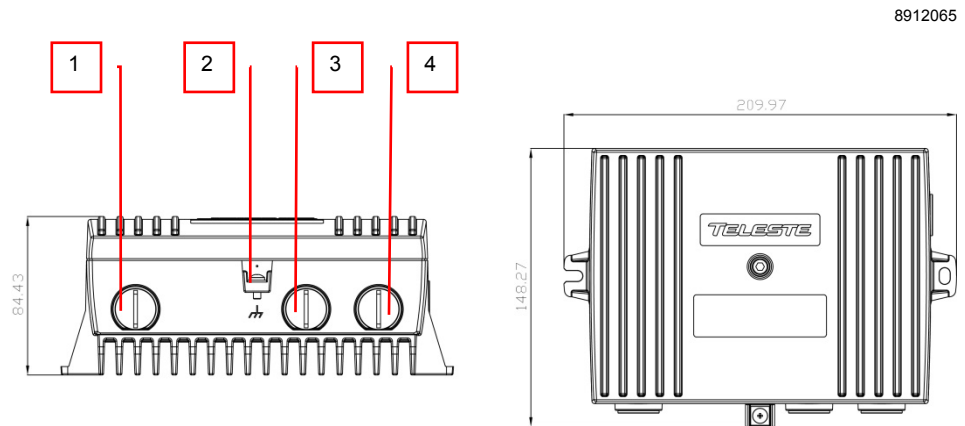

8912065

Figure 2. CXE880 Fibre Optic Receiver, 1) Optical fibre input port, 2) Ground, 3) Optical fibre output port, 4) RF output port

8905010

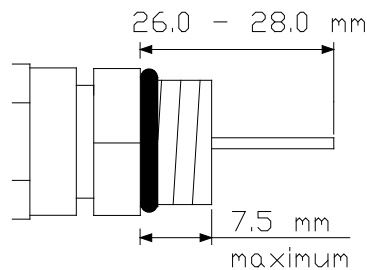

Figure 3. Centre conductor length

Fibre installation

The CXE880 fibre optic receiver and transmitter come as standard with a bulkhead mounted SC/APC adapter. Fibre installation is a critical procedure and it should be done carefully. Incorrect handling of the fibre can result in damage and degraded performance.

The node contains an internal fibre organiser. The fibre organiser provides termination, splicing and storage functions for fibre cables. The shielding cover of the node provides a protective enclosure for optical fibres and components.

Warning: The SC/APC adapter is connected to the integrated fibre receiver through a short length of fibre on the rear side of the bulkhead. To avoid

damage to the fibre, take care not to rotate the adapter when installing or removing the fibre connector.

Cleaning fibre connectors

- For correct optical operation ensure that all optical connectors are cleaned immediately before mating using a suitable optical connector cleaning kit.
 - If a cleaning kit is not available, wipe the end of the connector using pure isopropyl alcohol (99%) and a lint-free wipe. Dry it with filtered compressed air. Wait until dry to insert connector into the adapter.
 - When fibre optic connectors are unmated, the optical fibre end faces must be protected from contamination using suitable dust caps. Contamination of fibre end faces will reduce the performance of the optical fibre and could ultimately cause failure of the system. Contamination could also damage the fibre end faces when the connectors are mated.
-

Front panel

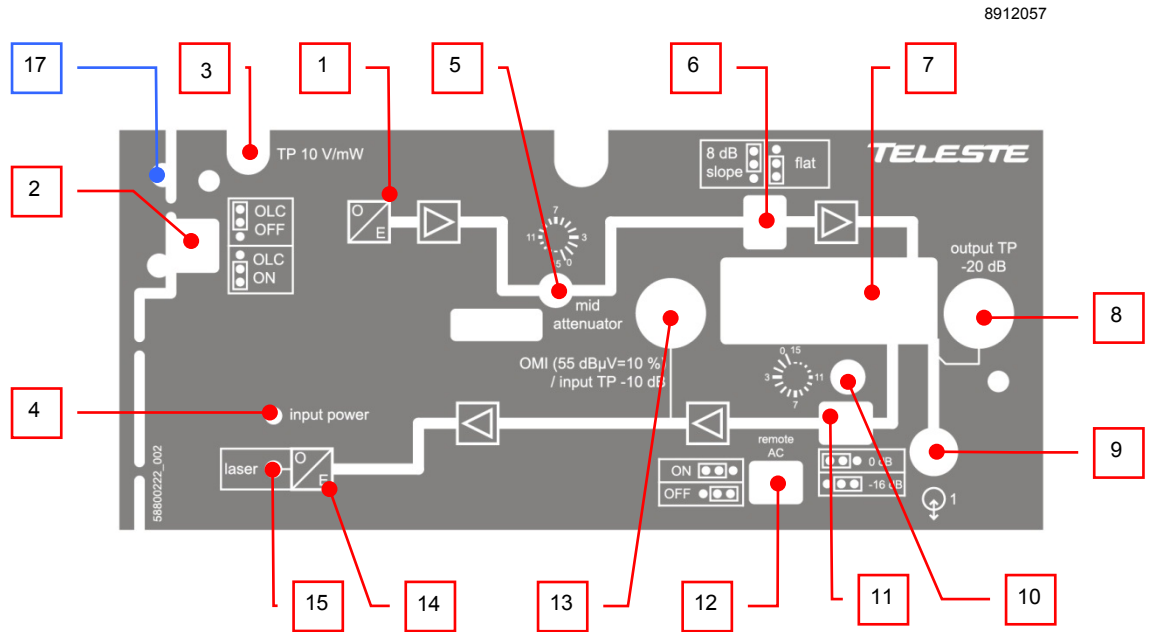

Figure 4. CXE880 front panel

- | | |
|---|---|
| <ul style="list-style-type: none"> 1) Integrated optical receiver 2) OLC mode jumper 3) Optical power DC voltage test point 4) LED indicator for optical input power 5) Midstage attenuator 6) Slope selection jumper 7) Output diplex filter 8) Output test point, -20 dB directional coupler 9) RF output port 10) Return path attenuator | <ul style="list-style-type: none"> 11) Return path attenuation mode jumper 12) Remote powering jumper for output 13) OMI test point 14) Integrated optical transmitter 15) LED indicator for optical output power 16) Ambient light sensor for lid status (optional status monitoring board) 17) LED indicator for alarm status (optional status monitoring board) |
|---|---|

OLC mode jumper (Fig. 3 pos. 2)	
Off	
On	

Return path attenuation mode jumper (Fig. 4 pos. 11)	
0 dB	
-16 dB	

Slope selection jumper (Fig 3. pos. 6)	
Sloped 8 dB	
Flat	

Remote powering jumper (Fig. 4 pos. 12)	
On	
Off	

Figure 5. Jumper configurations.

Features

Forward path / Optical receiver

The optical receiver is integrated within the CXE880 and will accept both 1310 and 1550 nm wavelength optical inputs. The optical receiver provides both LED indicator and DC voltage test point for received optical power to quickly determine status of the unit.

The output stage uses a GaAs MESFET output amplifier to improve RF performance over the entire 85 to 1006 MHz passband.

Optical input power

Optical input power can be measured from the optical power DC voltage test point (Figure 4 pos. 3). The test point DC voltage is directly proportional to optical input power in mW e.g. 10 V corresponds to 1.0 mW average optical power for 1310 nm. Table below shows the correct measurements at the test point using a 1310 nm or 1550 nm transmitter.

Operating wavelength 1310 nm		Operating wavelength 1550 nm	
TP / V DC	Input / dBm	TP / V DC	Input / dBm
10.0	0	11.2	0
7.9	-1	8.9	-1
6.3	-2	7.1	-2
5.0	-3	5.6	-3
4.0	-4	4.5	-4
3.2	-5	3.5	-5
2.5	-6	2.8	-6
2.0	-7	2.2	-7

Table 1. CXE880 optical receiver, expected levels.

Do not connect any voltage to the test point or short circuit it to ground. Use a voltage meter with an input resistance higher than 100 kΩ.

The mainboard provides also a LED indicator (Figure 4 pos. 4) which gives a visual indication of the optical input power.

Optical power LED	Condition
Yellow	Optical input power is below -7 dBm
Green	Optical input power is within the nominal range (-7...0 dBm)
Red	Optical input power exceeds 0 dBm

Table 2. LED indicator for optical input power on CXE880.

Forward path adjustment

The following are instructions to be used for a normal adjustment procedure.

1. Do not connect fibres or apply power before all the adjustments described below have been made.
2. Test the optical input power present on the fibre service cable using an optical power meter. The CXE880 integrated optical input power range is from -7 dBm to 0 dBm.
3. Optical Level Control (OLC) circuitry provides gain control that compensates for changes in input level caused by external variations. The available gain reserve is factory-set for optimum operation. If needed the output level can be adjusted with the midstage attenuator. You can however, set an internal jumper (Figure 4 pos. 2) to disable the OLC. This enables you to operate the CXE880 optical receiver at full gain for applications that do not require gain stabilization.
4. Use the midstage attenuator to get wanted output level. The network plan should specify exact signal levels. Refer to the Table 3 or Table 4.

Output level without OLC (dBµV)	Midstage attenuator (dB)
118	0
117	1
116	2
115	3
114	4
113	5
...	...

Table 3. Midstage attenuator selection when input power is -3 dBm at 4% OMI.

Output level with OLC (dB μ V)	Midstage attenuator (dB)
114	0
113	1
112	2
111	3
110	4
109	5
...	...

Table 4. Midstage attenuator selection when input power is between 0...-7 dBm at 4% OMI.

5. Use the response mode jumper (Figure 4 pos. 6) to select the midstage slope. Available options are "flat" or "8 dB sloped".
 6. Apply the power.
 7. Connect the fibre connector to the bulkhead adapter.
-

Return path / Optical transmitters

A diplex filter (Figure 4 pos. 7) is selected during configuration according to the preferred frequency split.

The CXE880 platform can be equipped either with a 1310 nm Fabry-Perot transmitter or with a CWDM transmitter. The CWDM lasers deploy eight wavelengths in range of 1470...1610 nm.

Return path adjustments

The return transmitter is aligned in production eliminating the need for any user adjustments. The level of return signal can be measured from the optical transmitter's OMI test point (Figure 4 pos. 13). In shielding cover of the CXE880 is described the fixed RF driving level at the OMI test point that gives 10% OMI. The return signal level should be adjusted to match this level. Table below shows the RF drive levels for different OMIs. The signal level is adjusted with the return path attenuator (Figure 4 pos. 10). The adjustment range is 15 dB. The attenuation can be approximately doubled with the return path attenuation mode jumper (Figure 4 pos. 11). Thus, it is possible to achieve higher attenuation with a maximum amount of 31 dB.

OMI (%)	RF – drive level (dBµV) from OMI test point
12	56.6
10 (default value)	55.0
8	53.1
6	50.6
4	47.0

For other OMI values, the needed adjustment setting can be calculated from the formula: Drive level = 55 dBµV + 20 x log (OMI_wanted / 10 %)

Depending on the nature of the return signal, the input level can be measured as follows:

- When using a reference or test signal the level of the carrier signal is measured from the test point and it is adjusted to a value shown in the unit's label or calculated from it.
- When using a digital noise like signal the spectrum analyser's noise marker is adjusted to the same bandwidth as the digital signal has and the level is adjusted to the value shown in the unit's label or calculated from it.

The mainboard provides also a LED indicator (Figure 4 pos. 15) which gives a visual indication of the laser bias current.

LED on CXE880	Condition
Yellow	Laser bias current is below the nominal range.
Green	The laser diode bias current is OK.
Red	Laser bias current exceeds the nominal range.

Table 5. LED indicator for optical output power on CXE880.

Legal declarations

Copyright © 2010 - 2012 Teleste Corporation. All rights reserved.

TELESTE is a registered trademark of Teleste Corporation. Other product and service marks are property of their respective owners.

This document is protected by copyright laws. Unauthorized distribution or reproduction of this document is strictly prohibited.

Teleste reserves the right to make changes to any of the products described in this document without notice and all specifications are subject to change without notice. Current product specifications are stated in the latest versions of detailed product specifications.

To the maximum extent permitted by applicable law, under no circumstances shall Teleste be responsible for any loss of data or income or any special, incidental, consequential or indirect damages howsoever caused.

The contents of this document are provided "as is". Except as required by applicable law, no warranties of any kind, either express or implied, including, but not limited to, the implied warranties of merchantability and fitness for a particular purpose, are made in relation to the accuracy, reliability or contents of this document.

Teleste reserves the right to revise this document or withdraw it at any time without notice.



Teleste Corporation
P.O. Box 323
FI-20101 Turku
FINLAND

www.teleste.com