

FORCE USA

OWNER'S MANUAL F-SQUAT

Squat Stands - Adjustable

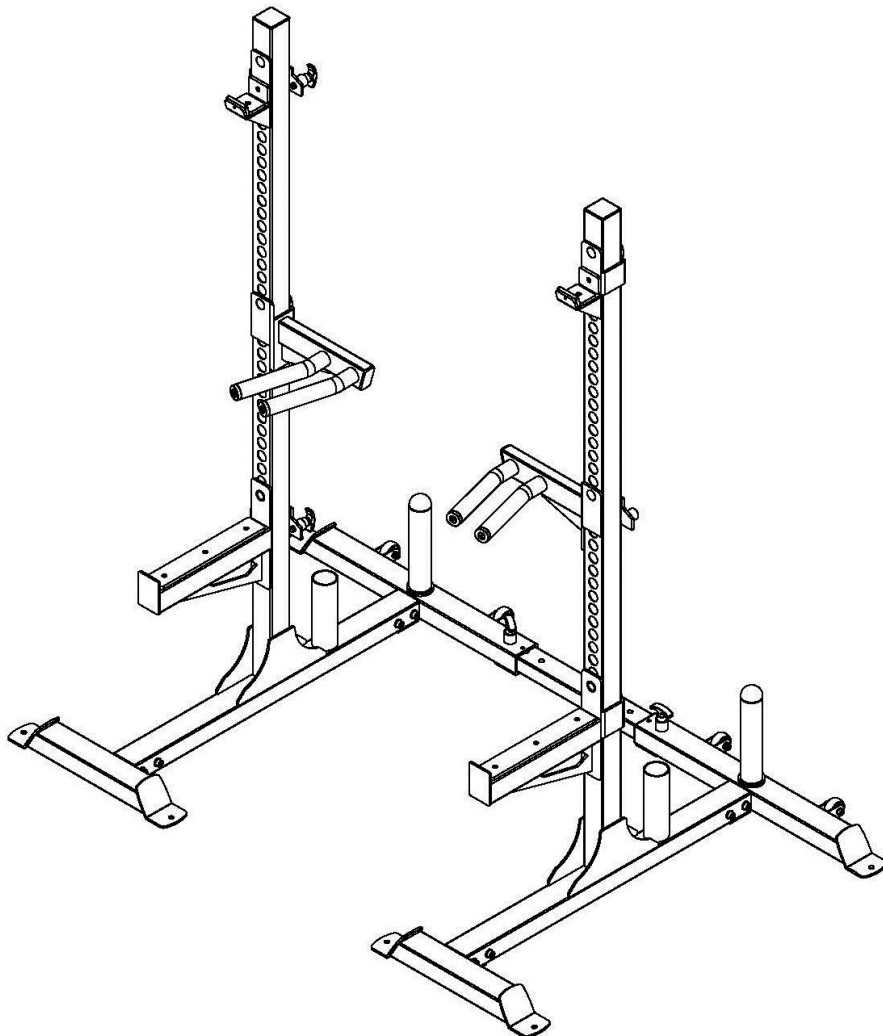

CAUTION!

Read all precautions and instructions in this manual before using this equipment.

ASSEMBLY MANUAL

FORCE USA SQUAT STANDS - ADJUSTABLE

BEFORE YOU START

Remove all parts from the packaging and separate and count each various component to ensure everything has been correctly provided.

Follow the instructions and consult both the individual assembly pages and the overall expanded views of the equipment.

Certain parts may arrive pre-assembled from the factory.

It is the owner's responsibility to ensure that all users of this unit have read the owner's manual and are familiar with the safety precautions.

SAFETY PRECAUTIONS

- Highly recommended for two or more people to assemble the equipment to avoid injury.
- Assemble the equipment on a flat level surface.
- Consider placing a mat under the equipment to protect your floor.
- Wear appropriate footwear and clothing during assembly and use.
- Only tighten nuts and bolts by hand until the whole equipment is assembled
- Ensure you correctly orientate each piece before attaching
- Do not allow children and pets to be unsupervised around the assembly or usage of this equipment.
- Ensure all parts are in full working order before use.
- Only one person should use the machine at any one time.
- Do not use the equipment outdoors or around water.
- Keep hair, fingers or clothing away from moving parts.
- Only use attachments recommended by the manufacturer.
- Never operate if any parts are not functioning correctly.
- Always correctly stretch and warm up before using the equipment.
- **Stop immediately** if you experience any pain, dizziness or nausea. See a doctor at once.

PLEASE NOTE: Descriptions of pieces as LEFT and RIGHT are from the point of view of standing behind the equipment facing towards the front.

BEFORE STARTING ANY EXERCISE PROGRAM, CONSULT YOUR DOCTOR. ESPECIALLY IF YOU ARE OVER THE AGE OF 35 OR HAVE PRE-EXISTING HEALTH PROBLEMS.

READ ALL INSTRUCTIONS BEFORE ASSEMBLING OR USING ANY FITNESS EQUIPMENT.

FORCE USA FITNESS EQUIPMENT ASSUMES NO RESPONSIBILITY FOR PERSONAL INJURY OR PROPERTY DAMAGE SUSTAINED BY OR THROUGH THE USE OF THIS PRODUCT.

SAVE THESE INSTRUCTIONS.

EXPLODED DIAGRAM

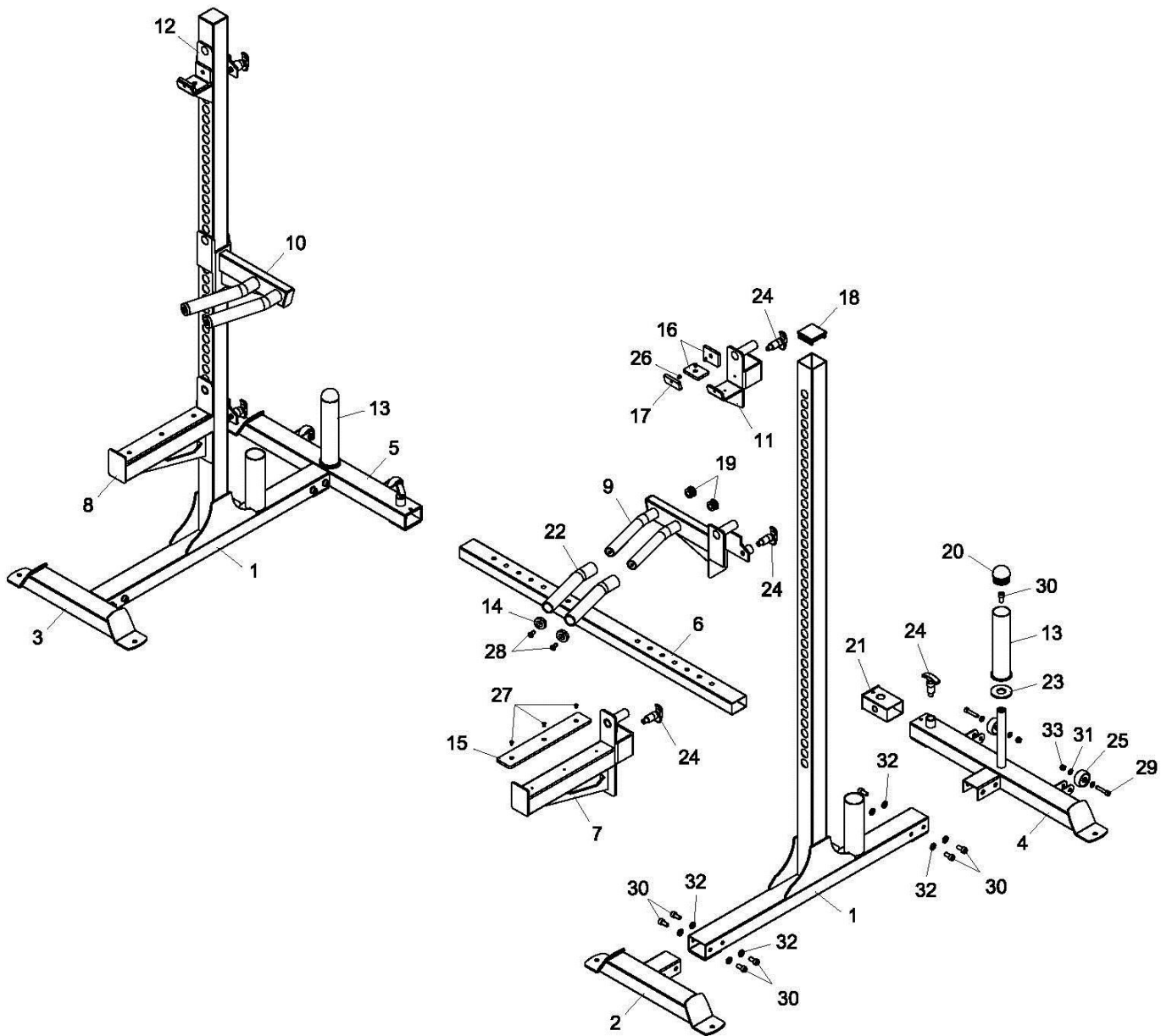

PART LIST

NUMBER	DESCRIPTION	Q'TY
1	UPRIGHT SUPPORT	2
2	RIGTH SHORT BASE	1
3	LEFT SHORT BASE	1
4	RIGHT LONG BASE	1
5	LEFT LONG BASE	1
6	JOINT TUBE	1
7	RIGHT HOLD SUPPORT	1
8	LEFT HOLD SUPPORT	1
9	RIGHT SUPPORT	1
10	LEFT SUPPORT	1
11	RIGHT BARBELL SUPPORT	1
12	LEFT BARBELL SUPPORT	1
13	PLATE ADAPTER	2
14	SHEATHING	4
15	LARGE RUBBER PLATE	2
16	RUBBER PLATE	4
17	SMALL RUBBER PLATE	2
18	SQUARE PLUG	2
19	ROUND PLUG	4
20	BALL HEAD ROUND PLUG	2
21	SQUARE BUSHING	2
22	FOAM ROLLER	4
23	RUBBER RING	2
24	FAST PIN	8
25	WHEEL	4
26	M5*10 SOCKET SCREW	6
27	M5*16 SOCKET SCREW	6
28	M8*25 SOCKET SCREW	4
29	M8*45 SOCKET CAP SCREW	4
30	M10*25 SOCKET CAP SCREW	18
31	WASHER 8MM	8
32	WASHER 10MM	16
33	LOCK NUT M8	4

STEP 01

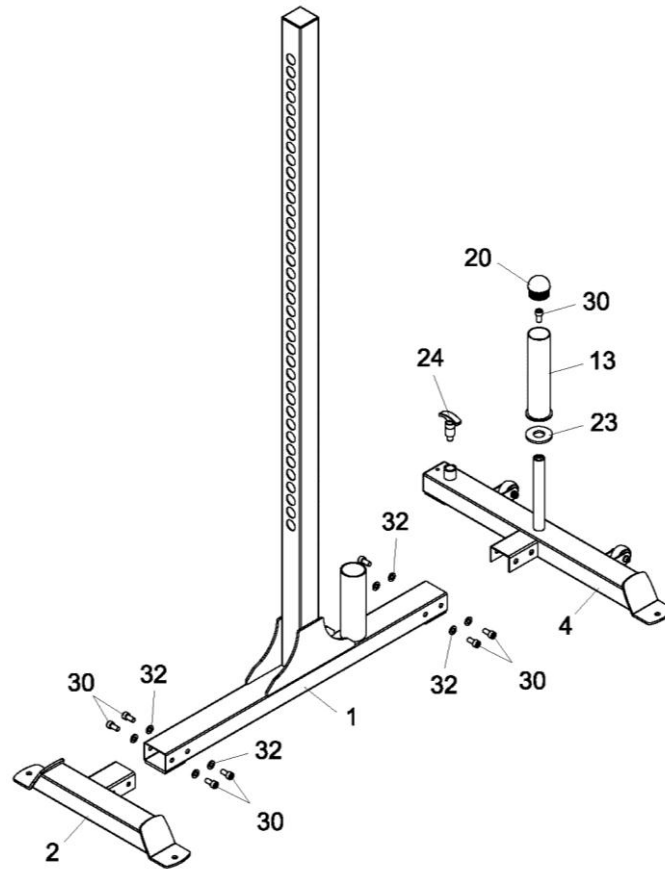

1. Slide RUBBER RING (23) and PLATE ADAPTER (13) onto RIGHT LONG BASE (4). Secure with SCREW M10*25 (30). Attach BALL HEAD ROUND PLUG (20) to PLATE ADAPTER (13).
2. Attach FAST PIN (24) to RIGHT LONG BASE (4).
3. Attach RIGHT LONG BASE (4) to UPRIGHT SUPPORT (1) using four SCREWS M10*25 (30) and four WASHERS 10MM (32).
4. Attach RIGHT SHORT BASE (2) to UPRIGHT SUPPORT (1) using four SCREWS M10*25 (30) and four WASHERS 10MM (32).
5. The assembly step of left side is the same as the right one.

STEP 02

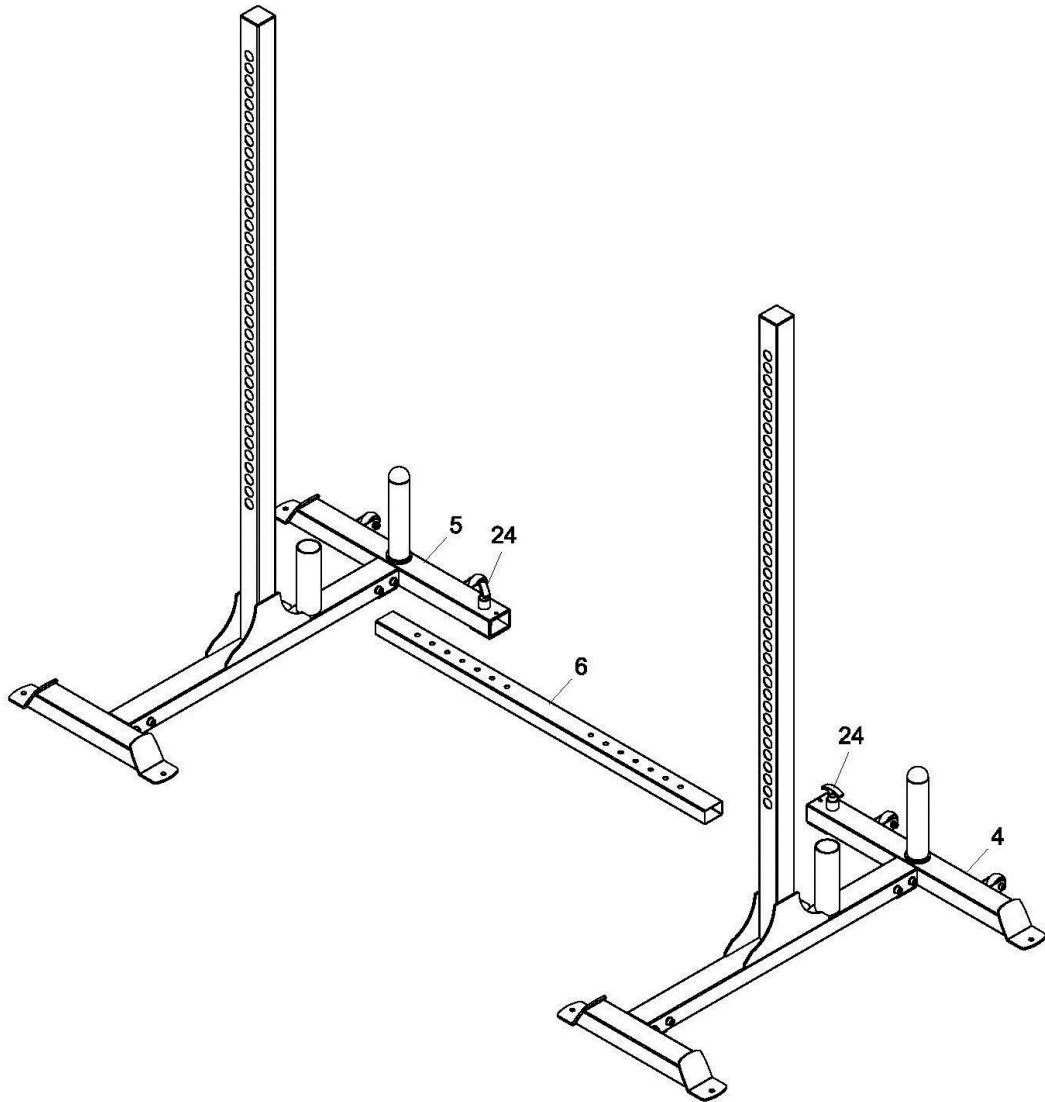

1. Insert JOINT TUBE (6) into port of RIGHT LONG BASE (4) and pull the FAST PIN (24) on RIGHT LONG BASE (4), select proper location and release the FAST PIN (24).
2. Insert JOINT TUBE (6) into port of LEFT LONG BASE (5) and pull the FAST PIN (24) on LEFT LONG BASE (5), select proper location and release the FAST PIN (24).

STEP 03

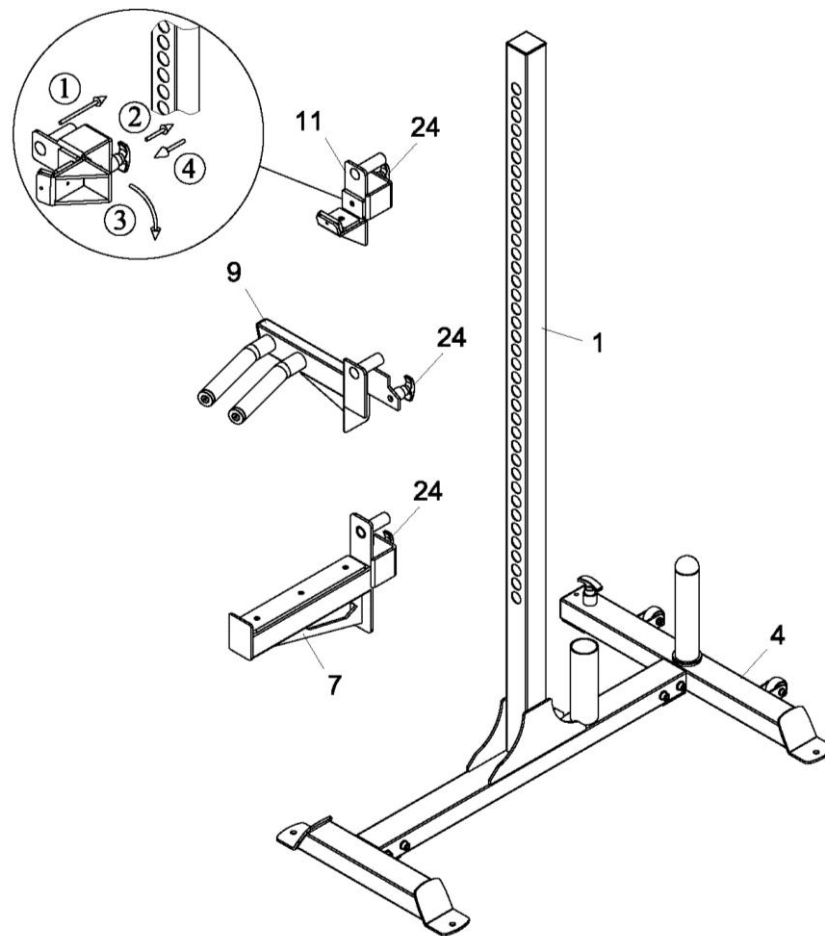

1. Attach the RIGHT BARBELL SUPPORT (11) to UPRIGHT SUPPORT (1).
 - ① Insert the axis on RIGHT BARBELL SUPPORT (11) into hole on UPRIGHT SUPPORT (1)
 - ② Pull the FAST PIN (24) on RIGHT BARBELL SUPPORT (11)
 - ③ Keep pull the FAST PIN (24) and rotating the RIGHT BARBELL SUPPORT (11)
 - ④ When the RIGHT BARBELL SUPPORT (11) is in the correct location, release the FAST PIN (24).
2. The RIGHT SUPPORT (9) and RIGHT HOLD SUPPORT (7) are the same assembly steps as the RIGHT BARBELL SUPPORT (11).\
3. The assembly step of left side is the same as the right one.



#26 M5 × 10 Socket Screw (Qty 6)

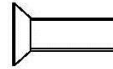

#27 M5 × 16 Socket Screw (Qty 6)

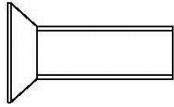

#28 M8 × 25 Socket Screw (Qty 4)

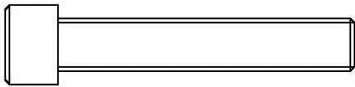

#29 M8 × 45 Socket Cap Screw (Qty 4)

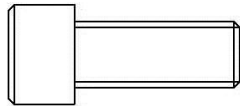

#30 M10 × 25 Socket Cap Screw (Qty 18)

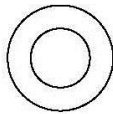

#31 Washer 8 (Qty 8)

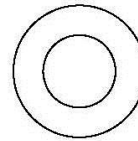



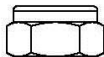



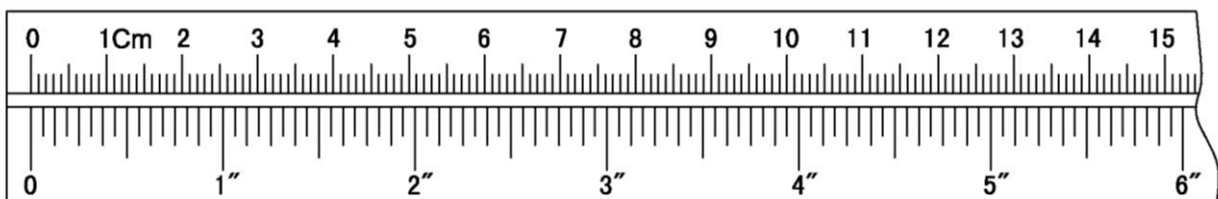





#32 Washer 10 (Qty 16)

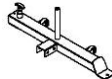
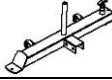
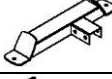
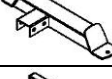

#33 M8 Lock Nut (Qty 4)



PACKING DETAILS

CARTON NO.	PART DESCRIPTION	PART NO.	VIEW	QUANTITY
CARTON 1	UPRIGHT SUPPORT	#1		2
	JOINT TUBE	#6		1
	BLISTER PACKAGE OF SCREWS			1
	MANUAL			1
	SMALL PARTS BAG			1
	TOOL BAG			1
CARTON 2	RIGHT LONG BASE	#4		1
	LEFT LONG BASE	#5		1
	RIGHT SHORT BASE	#2		1
	LEFT SHORT BASE	#3		1
	RIGHT SUPPORT	#9		1
	LEFT SUPPORT	#10		1
	RIGHT HOLD SUPPORT	#7		1
	LEFT HOLD SUPPORT	#8		1
	RIGHT BARBELL SUPPORT	#11		1
	LEFT BARBELL SUPPORT	#12		1
	PLATE ADAPTER	#13		2



LIFETIME WARRANTY ON FRAME

2 YEAR WARRANTY ON MOVING PARTS (Such as cables and pulleys)

Force USA, the Trusted Name in Strength Equipment™ was designed to be the best value strength equipment for home use and proudly set the benchmark for our home use equipment around the world. Offering one of the best warranties on the market for your peace of mind, each piece of Force USA strength equipment is hand crafted for quality and we use state-of-the-art production methods for our entire range. The Force USA range of strength equipment carries a Lifetime Structural Warranty along with 2 years cover on all cables and pulleys. This warranty applies to first owners and does not cover second hand equipment or re-sold equipment. This Force USA warranty covers only failures due to defects in structural, cables and pulleys and workmanship that occur during normal home use. It will not cover damage that occurs in transport/delivery or failure due to misuse, abuse, neglect, mis-application, alteration or improper assembly of the product. This warranty does not cover the use or failure of equipment in studio commercial applications. The replacement or repair provided for under the Force USA warranty is the responsibility of the user and the customer will be responsible for any freight charges applicable. Force USA will not be liable for any consequential damages or for breach of any implied warranty on the range of Force USA strength equipment. Force USA reserves the right to provide reconditioned parts and/or to request a return and repair existing defective parts on the Force USA product.

VorTex by Force USA is a commercial grade upholstery used for all Force USA equipment. We use a high grade commercial vinyl with rip-stop mesh backing which helps prevent rips and tears. Force USA, the Trusted Name in Strength Equipment™ was designed to be the best value strength equipment for home use and proudly set the benchmark for our home use equipment around the world.