



Variable Area Flow Meters

Inline Pneumatic Flow Meter



CONTENTS

Introduction	3
Operating Principle	4
Installation	5
Compressibility of Gases	5
Installation Recommendations	6
Installing the Flow Meter	6
Installing the Test Kit Flow Meter	8
Operation	9
Multi-Pressure Flow Scales	9
Single Pressure Flow Scales	9
Application Information	10
Maintenance	11
Removal of Dust Guard	11
Quick Recoupling	11
Test Kit Maintenance	11
Fluid Selection Chart	12
Flow vs. Pressure Drop	13
Air/Compressed Gases	13
Air/Compressed Test Kits	14
Air/Caustic and Corrosive Gases	14
Specifications	15
Materials of Construction	15
Dimensions	16
Standard Meters	16
Test Kits	17

INTRODUCTION

The Inline Pneumatic Flow Meter is a rugged industrial class flow rate indicator and is offered in aluminum, brass, T303 and T316 stainless steel models to monitor pressurized air lines and a wide range of other compressed gases. Available in seven port sizes from 0.25...3 inch for flow ranges from 0.5...5 scfm (0.2...2.2 l/sec) through 200...2200 scfm (75...1130 l/sec), meters are calibrated at 1.0 specific gravity. In addition to the basic model, the aluminum, brass and T303 stainless steel models are offered in three configurations: an extended inlet cap fitted with a pressure gauge, an extended inlet cap with a 0.25 inch NPTF plugged gauge port, and a test kit with an extended inlet cap fitted with a 160 psi pressure gauge and control valve on the outlet.

The Flow Meter is equipped with a 360° rotatable guard/scale which allows the meter to be installed in any orientation without regard to scale direction. Once the meter is permanently installed, the guard/scale can be rotated 360° to optimize readability.

The unique spring loaded design of this variable area flow meter allows it to be installed in any position, including inverted, without affecting accuracy. An optional inverted scale is available for these applications.

Aluminum models are offered as a rugged, low cost flow meter for monitoring noncorrosive pneumatic systems under operating pressures up to 1000 psi (69 bar), 250 psi (17 bar) for 3" models, and 600 psi (41 bar) for test kits.

Brass meters are recommended for applications with operating pressures up to 1000 psi (69 bar) without corrosion inhibitors.

Stainless Steel is available for monitoring systems operating at pressures up to 1500 psi (103 bar). The T316 stainless steel models are recommended for monitoring caustic or corrosive gases, such as hydrogen chloride or sulfur dioxide. The T303 stainless steel test kit is rated to 600 psi (41 bar); pressure rating is limited by the valve. For further construction material information, see *"Materials of Construction"* on page 15.

OPERATING PRINCIPLE

The Flow Meter is a variable area instrument. A sharp-edged orifice^①, located within the piston assembly^②, forms an annular opening with the contoured metering cone^③. The piston assembly carries a cylindrical PPS/ceramic magnet^④ that is magnetically coupled to an external indicating magnet^⑤ which moves precisely in direct response to movement of the piston. A calibrated spring^⑥ opposes flow in the forward direction.

The Hedland variable area flow meters are the most readable products in their class. Brightly colored indicators move over the graduated, linear flow scale^⑦ which contains bold, easy-to-read numeral and gauge marks. The enhanced resolution virtually eliminates parallax problems associated with competitive direct reading flow meters.

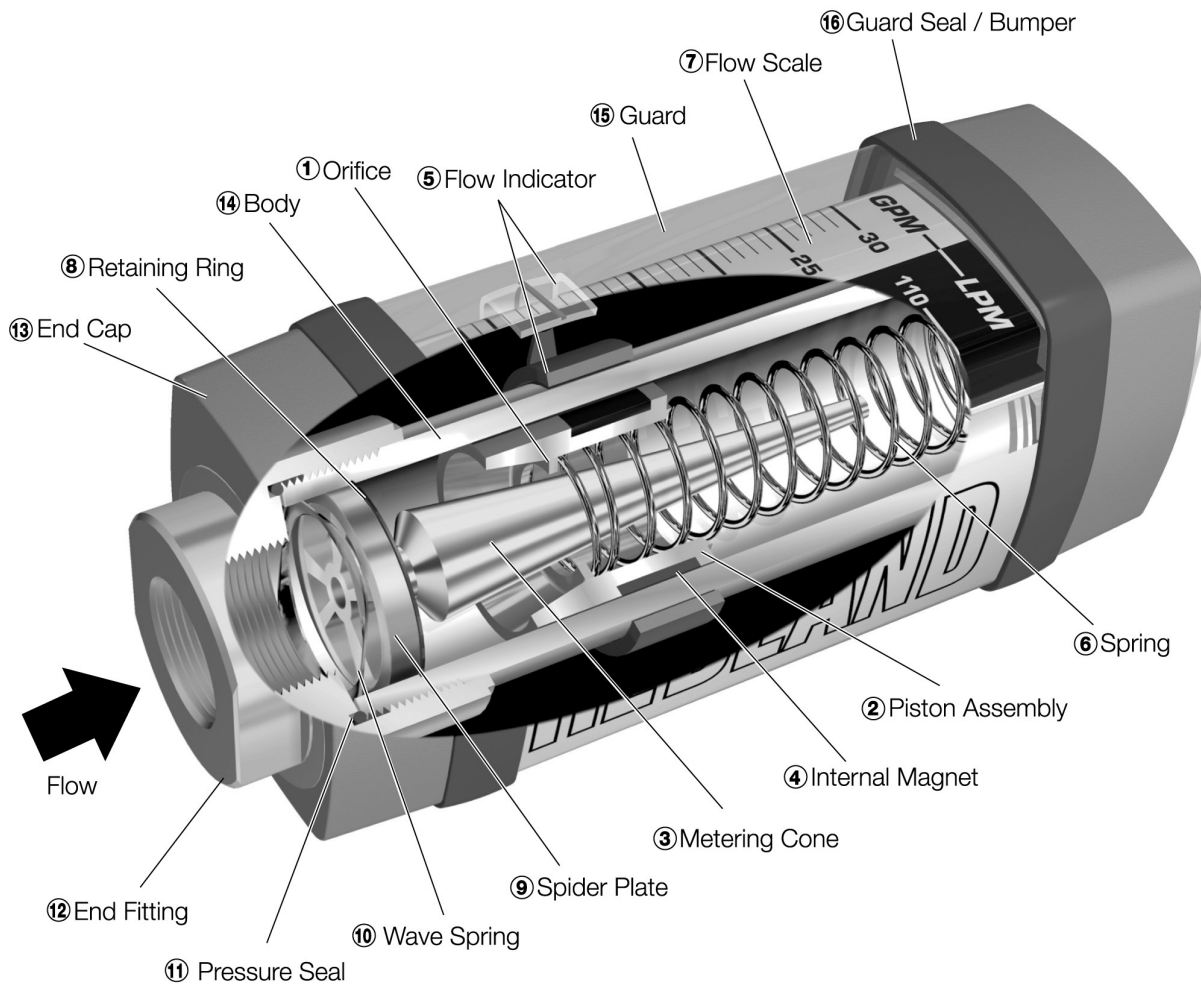

Figure 1: Inline pneumatic flow meter

INSTALLATION

⚠ CAUTION

THIS PRODUCT SHOULD BE INSTALLED AND SERVICED BY A TECHNICALLY QUALIFIED PERSONNEL TRAINED IN MAINTAINING INDUSTRIAL CLASS FLOW INSTRUMENTATION AND PROCESSING EQUIPMENT.

⚠ CAUTION

READ INSTRUCTIONS THOROUGHLY BEFORE INSTALLING THE UNIT. IF YOU HAVE ANY QUESTIONS REGARDING PRODUCT INSTALLATION OR MAINTENANCE, CALL YOUR LOCAL SUPPLIER FOR MORE INFORMATION.

⚠ CAUTION

THIS METER MAY CONTAIN RESIDUAL AMOUNTS OF TEST FLUID AT THE TIME OF SHIPMENT. THIS FLUID SHOULD BE REMOVED PRIOR TO INSTALLATION AS THE FLUID MAY BE INCOMPATIBLE OR HAZARDOUS WITH SOME LIQUIDS OR GASES. FAILURE TO FOLLOW THESE INSTRUCTIONS COULD RESULT IN DAMAGE TO THE EQUIPMENT.

⚠ CAUTION

THIS STANDARD METER IS UNIDIRECTIONAL. ATTEMPTS TO FLOW FLUIDS IN THE OPPOSITE DIRECTION OF THE FLOW ARROW WILL RESULT IN THE METER ACTING AS A CHECK VALVE, CREATING A DEADHEADING SITUATION. IF THE DIFFERENTIAL PRESSURE MAGNITUDE IS GREAT ENOUGH, DAMAGE TO THE INTERNAL PARTS OF THE METER WILL RESULT.

⚠ CAUTION

A LINE SNUBBER IS RECOMMENDED FOR APPLICATIONS IN WHICH RAPID VALVE ACTUATION OR PULSATION IS ANTICIPATED. THIS NOT ONLY REDUCES THE RISK OF DECOUPLING THE FLOW METER'S MAGNETIC PISTON, IT ALSO REDUCES EXCESSIVE WEAR ON OTHER COMPONENTS IN THE SYSTEM.

Compressibility of Gases

Gases are significantly compressible so the density of any compressed gas will vary according to changes in operating pressure levels. In other words, volumetric flow rates will vary significantly with changes in line pressure. Therefore, pneumatic flow meters should be installed with a pressure gauge located as close as possible to the inlet port. The psig range capacity of this pressure gauge should be at least 125% of the anticipated pressure in the system, or be suitable for the maximum expected line pressure (if higher). For example, if the anticipated operating pressure is 100 psig, a pressure gauge with a capacity of at least 125 psig should be installed as close as possible to the inlet port.

Installation Recommendations

The inline flow meter is a simple device to install. However, the following measures are recommended for reliable, trouble-free operation:

1. Piping should be accurately aligned and of correct length. The high pressure body of the flow meter can withstand shock and flow/pressure pulsation. However, the piping should be firmly supported by external mounting brackets, both upstream and downstream of the meter, to avoid any pipe flexing actions that could reduce meter life.
2. If the flow meter inlet or outlet are to be rigidly mounted, and the opposing port is to be connected to a flexible hose, the end connected with the flexible hose must be rigidly mounted.
3. Use Teflon® tape for sealing NPT fitting.
4. Install a union near the inlet or outlet of the meter for quick, easy meter removal and inspection during periodic maintenance procedures.
5. Mount the meter either horizontally or vertically (flow arrow pointing to either side or straight up). If the meter must be mounted inverted, special inverted scales are available.
6. Ensure the fluid is traveling in the direction of the flow arrow (*see Figure 2*).
7. Systems that do not have filtration should be equipped with at least a 200 mesh (74 micron) filter. Most systems already have much finer filtration. The meter will allow particulate to pass that would jam most valves and flow controls. Dirt, ferrous metal or sealing agents, such as Teflon® tape may lodge and cause malfunction. If the meter is jammed at a fixed position, see "Removal of Dust Guard" on page 11.
8. Do not use thread locking compounds as thread sealant.
9. Do not install the flow meter near turbulence producing fittings such as elbows, reducers and close coupled valves for maximum reliability. The inline flow meter does not require flow straighteners or special lengths of straight inlet/outlet piping to stabilize turbulent flow patterns.
10. Do not install the meter near fast-acting valves. Fast-acting valves have the potential to create high magnitude hydraulic pressure spikes. These spikes can damage the internal components of the meter, resulting in inaccuracies or malfunction.
11. Do not allow unidirectional meters to be operated against the direction of the flow arrow. The standard flow meter is an unidirectional flow meter. The piston acts as a check valve to block flow in the reverse direction. This causes an excessive pressure differential, which can result in damage to internal meter components.

Installing the Flow Meter

1. Mount the meter so fluid is traveling in the direction of the flow arrow. See *Figure 1 on page 4*.

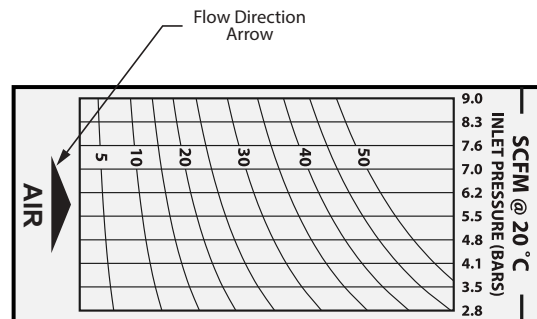
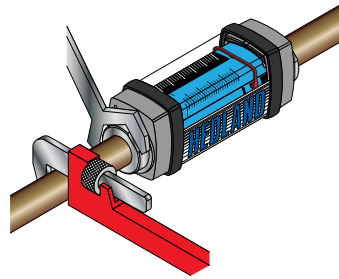
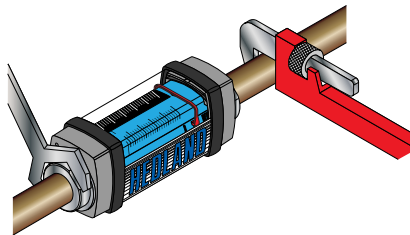

Figure 2: Flow direction arrow

2. Select a mounting location that is suitable for viewing and product service. To connect the flow meter into the piping system, place an open-ended wrench onto the flow meter wrench flats adjacent to the pipe connection being installed. DO NOT wrench on the opposite end of the flow meter or leakage may result. See *Figure 3 on page 7*.



Place wrench on meter flats on the same side plumbing is being tightened



Never place wrench on meter flats opposite plumbing being tightened

Figure 3: Installing meter

3. After installation, rotate the meter by hand to the view flow scale. See Figure 4.

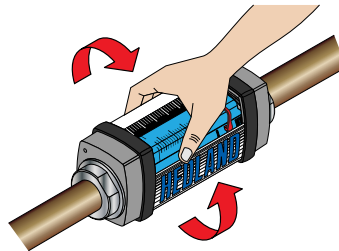

Rotate meter by hand to view flow scale

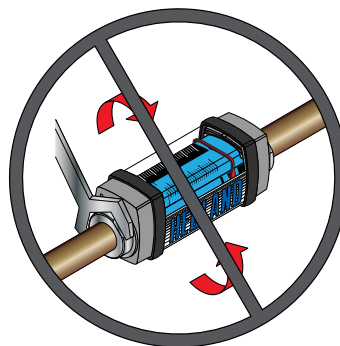

Never use wrench to rotate meter body when viewing flow scale

Figure 4: Rotating meter

Installing the Test Kit Flow Meter

1. Mount the VA High Pressure Test Kit Flow Meter so fluid is traveling in the direction of the flow arrow. See *Figure 2 on page 6*.
2. Install the test kit at any location in the pneumatic circuit that is suitable for viewing. To connect the test kit into the piping system, place an open-ended wrench onto the test kit extended cap on the inlet side or on the test kit wrench flat on the outlet side adjacent to the pipe connection being installed. Do not wrench on the opposite end of the test kit or leakage may result. See *Figure 5*.

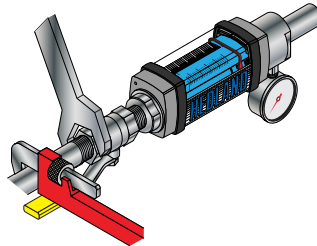

Place wrench on valve body
on the same side plumbing is being tightened

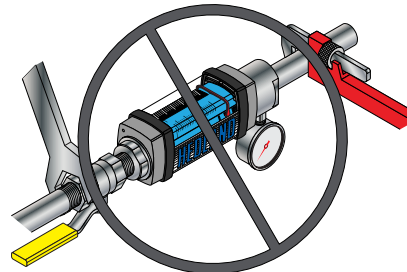

Never place wrench on valve body
opposite plumbing being tightened

Figure 5: Installing test kit

Or, use quick disconnect couplings for easy connections and to keep the test kit sealed and clean when not in use.

3. After installation, rotate the meter by hand to the view flow scale. See *Figure 6*.

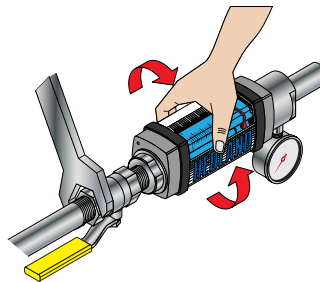

Rotate meter by hand to view flow scale

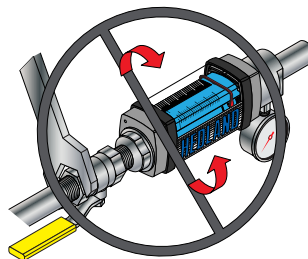

Never use wrench to rotate meter
body when viewing flow scale

Figure 6: Rotating test kit

OPERATION

Multi-Pressure Flow Scales

The inline pneumatic flow meter is offered with a multi-pressure flow scale to visually indicate air flow rates in standard cubic feet per minute (scfm) at 1.0 s.g. (70° F at 100 psi) or liters per second (l/sec) at 1.0 s.g. (21° C at 6.9 bar). The multi-pressure scale design allows for use at line pressures from 40...130 psi in 10 psi increments (3.0...9.0 bar in 1 bar increments). This configuration requires that a pressure gauge be installed at the meter inlet.

Read the inlet gauge pressure then select the appropriate vertical line or interpolated value closest to the gauge reading and follow the line until it intersects the brightly colored horizontal indicator bar. The flow rate is read by taking the intersection points, following the slope of the closest diagonal line to a scale value and interpolating the scfm (l/sec) flow rate. No further calculations are required. See *Figure 7*.

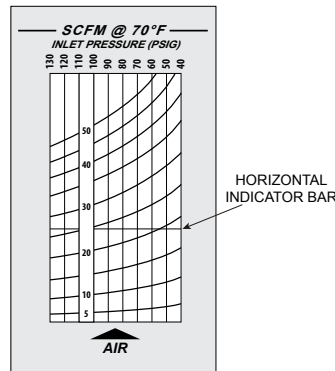

Figure 7: Multi-pressure flow scale

Single Pressure Flow Scales

An optional single pressure flow scale is available in U.S. or metric units. This graduated scale is calibrated for air in standard cubic feet per minute (scfm) at 1.0 s.g. (70° F at 100 psi), or liters per second (l/sec) at 1.0 s.g. (21° C at 6.9 bar). See *Figure 7*. A standard cubic foot of air is defined as a cubic foot of air at 70° F at atmospheric pressure 14.7 psia at sea level. Since it is impossible to flow air at “standard” conditions, the scale is calibrated for an inlet condition of 100 psi (6.9 bar) at 70° F (21° C). A correction factor must be calculated to determine the actual air volume. Each meter is supplied with the Conversion Chart, see “Conversion Chart” on page 10.

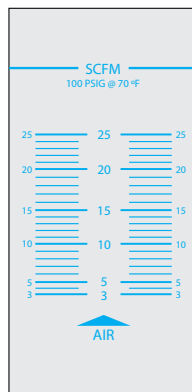

Figure 8: Single pressure flow scale

Application Information

Compressibility of Gases

Gases are significantly compressible so their density varies with pressure and temperature. Use *Table 1* to convert indicated scfm flow rates to actual scfm flow rates for your application.

Effects of Specific Gravity

Standard scales are calibrated for air with a specific gravity of 1.0. Use *Table 3* of the conversion chart to calculate “actual” scfm flow rates of gases with a specific gravity other than 1.0.

Conversion Chart

The conversion chart provides a series of simplified mathematical formulas to adjust the graduated scale for changes in pressure (see *Table 1*), temperature (see *Table 2*), or specific gravity (see *Table 3*). Special scales can be made to accommodate other pressures, temperatures and specific gravity.

The conversion chart can also be used to adjust the multi-pressure flow scale to indicate flow rates in applications beyond the parameters stated on the scale.

To adjust for pressures beyond (above or below) scale limits:

1. Locate point at which the brightly colored indicator line intersects the vertical 100 psig pressure line.
2. Divide this reading by the pressure correction factor (f_1) indicated in the conversion chart.

To adjust for changes in temperature:

1. Divide the 100 psig flow rate reading by temperature correction factor (f_2).

To adjust for changes in specific gravity:

1. Establish the square root of the new specific gravity.
2. Divide the 100 psig flow rate reading by the specific gravity correction factor (f_3).

psig	25	50	75	100	125	150	175	200	225	250
bar	1.7	3.5	5.2	6.9	8.6	10.4	12.1	13.8	15.5	17.2
kPa	172	345	517	689	862	1034	1207	1379	1551	1724
f_1	1.700	1.331	1.131	1.000	0.902	0.835	0.778	0.731	0.692	0.658
$f_1 = \sqrt{\frac{114.7}{14.7 + psig}}$				$f_1 = \sqrt{\frac{7.914}{1.014 + BAR}}$			$f_1 = \sqrt{\frac{790.857}{101.357 + kPa}}$			

Table 1: Pressure correction factor

°F	+10	+30	+50	+70	+90	+110	+130	+150	+170	+190
°C	-12.2	-1.1	+9.09	+21.0	+32.1	+43	+54	+65	+76	+88
f_2	0.942	0.962	0.981	1.000	1.018	1.037	1.055	1.072	1.090	1.107
$f_2 = \sqrt{\frac{460 + °F}{530}}$					$f_2 = \sqrt{\frac{273 + °C}{293}}$					

Table 2: Temperature correction factor

$f_3 = \sqrt{Sp. Gr.}$										
------------------------	--	--	--	--	--	--	--	--	--	--

Table 3: Specific gravity correction factor

MAINTENANCE

⚠ WARNING

BEFORE ATTEMPTING TO REMOVE THE FLOW METER FROM THE LINE, CHECK THE SYSTEM TO CONFIRM THAT LINE PRESSURE HAS BEEN REDUCED TO ZERO PSI. FAILURE TO FOLLOW THESE INSTRUCTIONS COULD RESULT IN SERIOUS PERSONAL INJURY OR DEATH AND/OR DAMAGE TO THE EQUIPMENT.

1. Remove the flow meter from the line. Remove excess piping from meter.

NOTE: It is not necessary to remove the transparent dust guard from the meter to remove the meter from the line. If you choose to remove the dust guard assembly, see "Removal of Dust Guard" on page 11.

2. Thoroughly wipe off the entire flow meter surface using mild detergent or isopropyl alcohol.

⚠ CAUTION

DO NOT USE AROMATIC HYDROCARBONS, HALOGENATED HYDROCARBONS, KETONES OR ESTER BASED FLUIDS ON POLYCARBONATE LENS. FAILURE TO FOLLOW THESE INSTRUCTIONS COULD RESULT IN DAMAGE TO THE METER.

3. Remove the inlet cap from the flow meter, noting the sequence of disassembly for later reference.
4. The internal parts are secured with a retaining ring. Remove the retaining ring and the internal wetted parts from the flow meter.

NOTE: If internal parts do not slide freely from flow meter, use a wooden dowel inserted into the outlet port of the meter to push parts out.

5. Place all parts on a clean work surface. Clean and inspect all parts. Replace any that appear worn or damaged.
6. Check inlet port O-ring for damage and replace if required.
7. Reassemble the spring, the piston/magnet assembly and the retaining ring into the flow meter.
8. Install the metering cone/spider plate assembly and the retaining spring. Secure with inlet cap.
9. Reinstall the meter to the line.

Removal of Dust Guard

To remove the dust guard for cleaning or replacement, simply loosen the end fitting located at the bottom of the meter and slide the end cap, dust bumper, and the dust guard off the bottom of the meter, taking care to avoid damaging the O-ring seal between the end cap and the dust gland.

Quick Recoupling

This piston type variable area flow meter is inherently less sensitive to shock and vibration than other variable area designs. The unique magnetic coupling also eliminates the need for mechanical linkages that can wear or loosen over the functional life of the meter.

However, on occasion, a pressure spike or extreme flow surge can cause the piston to move at such rapid speed that it disconnects the piston magnet and the external indicator ring. If this occurs, use one of these procedures to re-couple the magnet and the external indicator ring:

- If the system permits, simply change flow rate from "no flow" to "full flow" allowing the moving piston to magnetically re-couple to the indicator ring.
- For rigorous cyclical applications where decoupling may occur frequently, consult the technical services.

Test Kit Maintenance

Load Valve

If the valve fails to load the system, remove the valve body and check for foreign material, worn parts or seals.

Flow

The absence of any flow reading may indicate a seized piston assembly. Remove any material that may be preventing the piston to slide. If the Test Kit still fails to indicate flow, return the Test Kit to the factory.

FLUID SELECTION CHART

Fluid	Specific Gravity	Correction Factor of Standard Scale	Internal Body Material				External Pressure Seals		Dust Guards		
			Aluminum	Brass	T316SS	T303SS	Viton®	EPR	Polycarbonate	Nylon	Pyrex
Air	1.00	1.000	R	R	R	R	R	R	R	R	R
Argon (A)	1.38	1.175	R	R	R	R	R	R	R	R	R
Carbon Dioxide (CO ₂)	1.53	1.237	R	R	R	R	R	R	R	R	R
Freon 11 (CCI ₃ F)	4.92	2.218	R	R	R	R	R	R	R	R	R
Freon 12 (CCI ₂ F)	4.26	1.060	R	R	R	R	R	R	R	R	R
Helium (HE)	0.14	0.374	R	R	R	R	R	R	R	R	R
Hydrogen (H ₂)	0.07	0.265	R	R	R	R	R	R	R	R	R
Natural Gas	0.60	0.775	C	C	R	C	R	N	C	R	R
Nitrogen (N ₂)	0.97	0.985	C	C	R	R	R	R	R	R	R
Oxygen (O ₂)	1.10	1,049	R	R	R	R	R	R	R	R	R
Propane (C ₃ H ₈)	1.57	1.253	R	R	R	R	R	R	N	R	R

R = Recommended
 N = Not Recommended
 C = Consult Factory

Table 4: Fluid selection chart

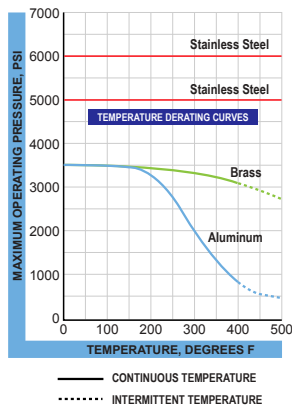

Figure 9: Pressure vs. temperature chart

FLOW VS. PRESSURE DROP

Air/Compressed Gases

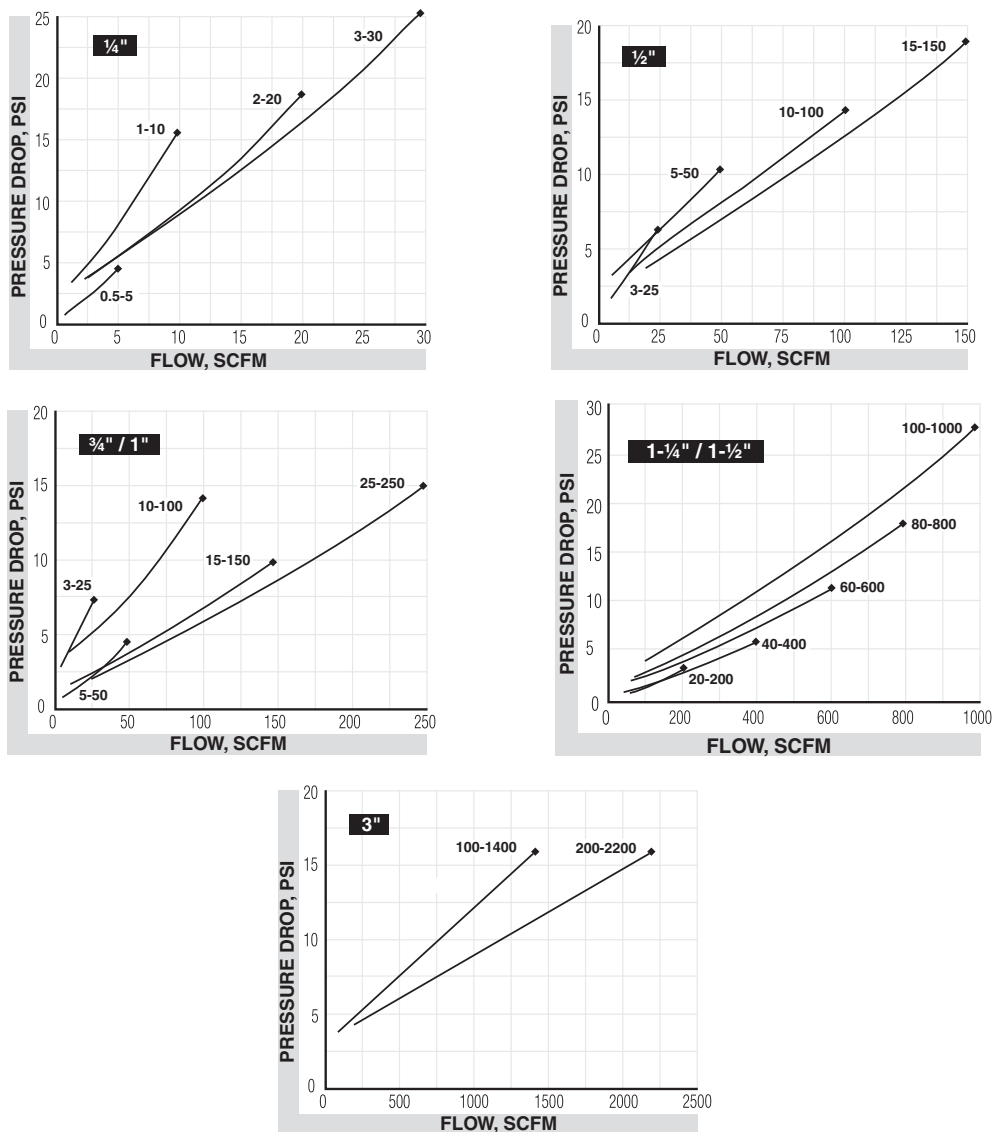

Figure 10: Air and compressed gases flow vs pressure change

1. The pressure drop curves are valid for fluids with density and viscosity similar to factory test fluids. Fluids, especially with higher viscosity than these test fluids, will yield a higher pressure drop through the flow meter and piping system per a given flow volume.
2. A system must have adequate fluidic horsepower available to move the system fluid at a prescribed rate at a pressure adequate to overcome all pressure reducing devices, including the flow meter.

Air/Compressed Test Kits

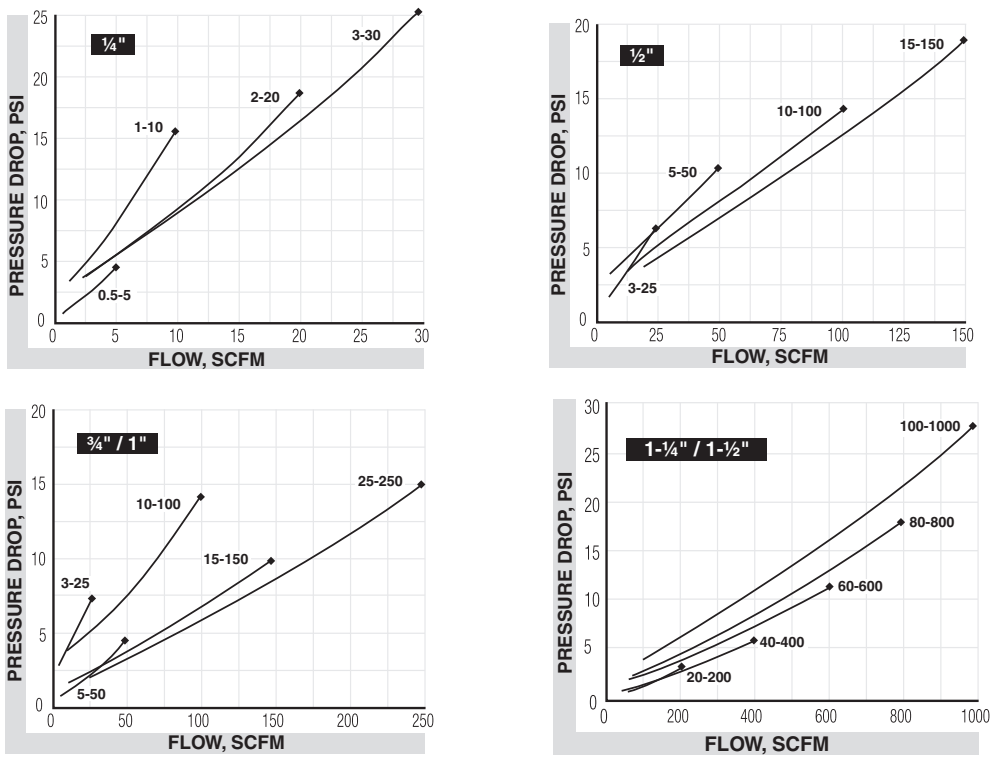

Figure 11: Air and compressed gases flow vs pressure drop test kits

Air/Caustic and Corrosive Gases

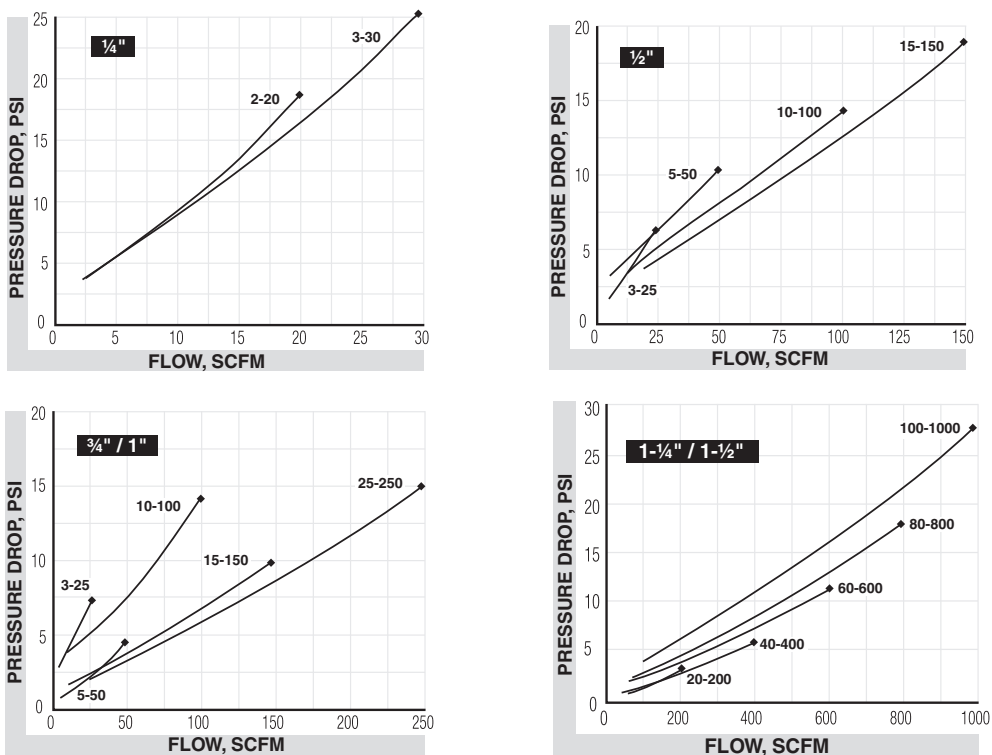

Figure 12: Caustic air and corrosive gas flow vs pressure drop

SPECIFICATIONS

Temperature Range	Standard	-20...240° F (-29...116° C)
	Hostile environment:	-20...400° F (-29...205° C) Continuous 400...500° F (205...260° C) Intermittent
	See "Pressure vs. temperature chart" on page 12 for more information.	
Pressure Rating (10:1 safety factor)	Aluminum/brass models	1000 psi (69 bar) maximum 3" Sizes; 250 psi (17 bar) maximum
	Stainless steel models	1500 psi (103 bar) maximum
	Test kit models (Aluminum/brass/SS)	600 psi (41 bar) maximum
Pressure Drop	See "Flow vs. Pressure Drop" on page 13 for specific meter information	
Accuracy	±2% of full scale	
Repeatability	±1%	
Threads	SAE J1926/1, NPTF ANSI B2.2, BSPP ISO1179, BSPT (BS21)	
Test Kit Pressure Gauge (Glycerin Dampened)	0...160 psi (0...10 bar)	
Test Kit Load Valve	Ball valve with chrome plated brass ball and Teflon® seals	

Materials of Construction

Basic Flow Meters and Test Kits

Body	Piston	Cone	Spider Plate	Spring	Fasteners	Pressure Seals	Guard	Retaining Ring	Retaining Spring	Indicator & Internal Magnet	Guard Seal/Bumper	Scale Support	End Caps
2024 T351 Anodized Aluminum			T316SS	T302SS	T303SS	Viton®	Poly-carbonate	T316SS	T316SS	PPS/Ceramic	Buna N	6063-T6 Aluminum	Nylon ST
C30 Brass ¹													
T303SS ²	2024-T351 Anodized Aluminum												

¹ 3" Models have Celcon piston/piston ring

² 3" Models not available in T303SS^o

Table 5: Basic flow meters and test kits

Caustic and Corrosive Air and Gases (Standard Model)

Body	Piston	Cone	Spider Plate	Spring	Fasteners	Pressure Seals	Guard	Retaining Ring	Retaining Spring	Indicator & Internal Magnet	Guard Seal/Bumper	Scale Support	End Caps
T316SS			T316SS	T316SS	T316SS	Viton	Poly-carbonate	T316SS	T316SS	PPS/Ceramic	Buna N	6063-T6 Aluminum	Nylon ST

Table 6: Caustic and corrosive air and gases (standard)

Caustic and Corrosive Air and Gases (Hostile Environment Model)

Body	Piston	Cone	Spider Plate	Spring	Fasteners	Pressure Seals	Guard	Retaining Ring	Retaining Spring	Indicator & Internal Magnet	Bumper	Scale Support	End Caps
T316SS			T316SS	T316SS	T316SS	Viton	Cylindrical Pyrex Glass®	T316SS	T316SS	Indicator: T416SS Magnet: Teflon® Coated Alnico 8	T316SS	T316SS	T316SS

Table 7: Caustic and corrosive air and gases (hostile)

DIMENSIONS

Standard Meters

A Nominal Port Size	B Length in. (mm)	B ₁ Length in. (mm)	C Width in. (mm)	D Depth in. (mm)	E Offset in. (mm)	F Flats in. (mm)	G Height in. (mm)
1/4 (SAE 6)	4.80 (122)	6.12 (155)	1.68 (43)	1.90 (48)	0.82 (21)	0.88 (22)	5.00 (127)
1/2 (SAE 10)	6.60 (168)	8.00 (203)	2.07 (53)	2.40 (61)	1.04 (32)	1.25 (32)	5.40 (137)
3/4 (SAE 12)	7.20 (183)	8.90 (226)	2.48 (63)	2.85 (72)	1.24 (32)	1.50 (38)	5.90 (150)
1 (SAE 16)	7.20 (183)	8.90 (226)	2.48 (63)	2.85 (72)	1.24 (32)	1.75 (44)	5.90 (150)
1-1/4 (SAE 20)	12.20 (310)	13.80 (351)	4.12 (105)	4.72 (120)	2.06 (52)	2.75 (70)	7.20 (183)
1-1/2 (SAE 24)	12.20 (310)	13.80 (351)	4.12 (105)	4.72 (120)	2.06 (52)	2.75 (70)	7.20 (183)

Table 8: Standard meters

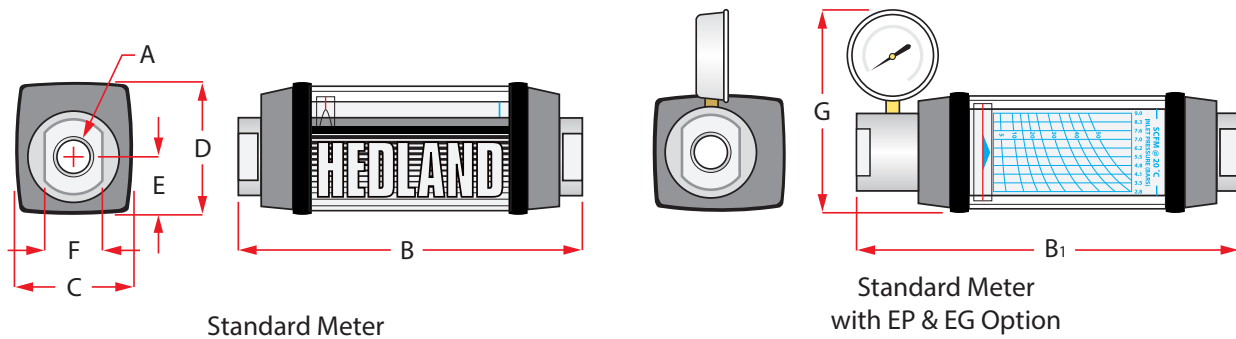

Figure 13: 1/4 to 1-1/2 inch models

3 inch; SAE, NPTF, BSPT models—inches (mm)

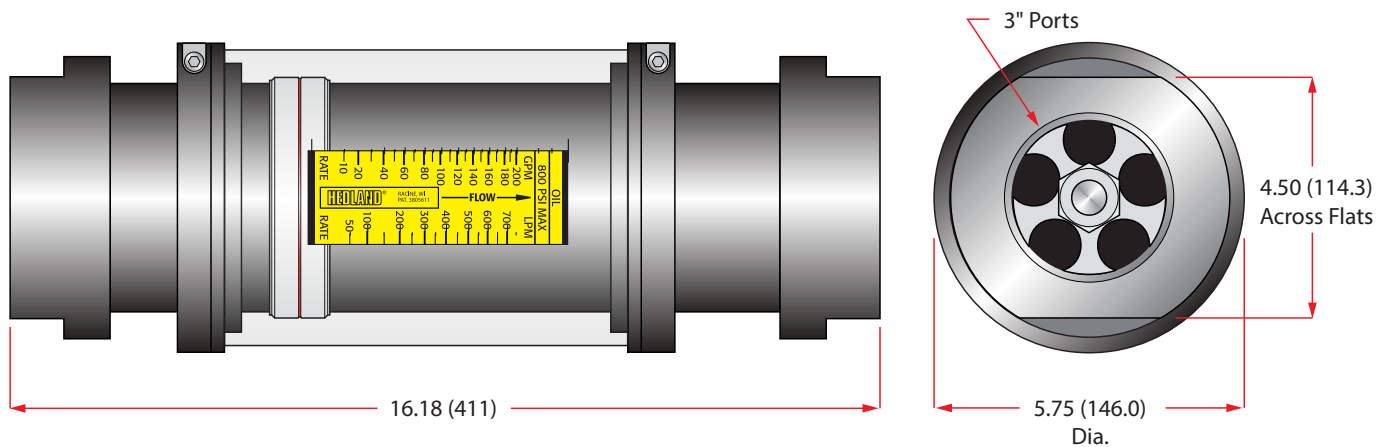

Figure 14: Three inch SAE, NPTF, BSPT models (measurements in inches [mm])

Test Kits

A Nominal Port Size	B Length in. (mm)	B₁ Length in. (mm)	C Width in. (mm)	D Depth in. (mm)	E Offset in. (mm)	F Flats in. (mm)	G Height in. (mm)
1/4 (SAE 6)	4.80 (122)	6.12 (155)	1.68 (43)	1.90 (48)	0.82 (21)	0.88 (22)	5.00 (127)
1/2 (SAE 10)	6.60 (168)	8.00 (203)	2.07 (53)	2.40 (61)	1.04 (32)	1.25 (32)	5.40 (137)
3/4 (SAE 12)	7.20 (183)	8.90 (226)	2.48 (63)	2.85 (72)	1.24 (32)	1.50 (38)	5.90 (150)
1 (SAE 16)	7.20 (183)	8.90 (226)	2.48 (63)	2.85 (72)	1.24 (32)	1.75 (44)	5.90 (150)
1-1/4 (SAE 20)	12.20 (310)	13.80 (351)	4.12 (105)	4.72 (120)	2.06 (52)	2.75 (70)	7.20 (183)
1-1/2 (SAE 24)	12.20 (310)	13.80 (351)	4.12 (105)	4.72 (120)	2.06 (52)	2.75 (70)	7.20 (183)

Table 9: Test kit dimensions

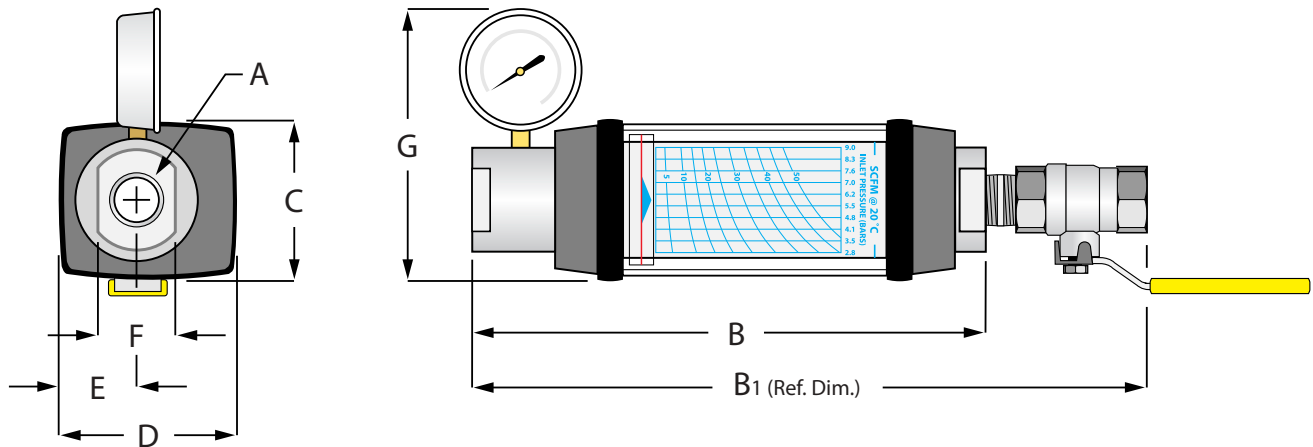

Figure 15: Test kit dimensions

INTENTIONAL BLANK PAGE

INTENTIONAL BLANK PAGE

Control. Manage. Optimize.

HEDLAND is a registered trademark of Badger Meter, Inc. Other trademarks appearing in this document are the property of their respective entities. Due to continuous research, product improvements and enhancements, Badger Meter reserves the right to change product or system specifications without notice, except to the extent an outstanding contractual obligation exists. © 2014 Badger Meter, Inc. All rights reserved.

www.badgermeter.com

The Americas | Badger Meter | 4545 West Brown Deer Rd | PO Box 245036 | Milwaukee, WI 53224-9536 | 800-876-3837 | 414-355-0400
México | Badger Meter de las Americas, S.A. de C.V. | Pedro Luis Ogazón N°32 | Esq. Angelina N°24 | Colonia Guadalupe Inn | CP 01050 | México, DF | México | +52-55-5662-0882
Europe, Middle East and Africa | Badger Meter Europa GmbH | Nurtinger Str 76 | 72639 Neuffen | Germany | +49-7025-9208-0
Europe, Middle East Branch Office | Badger Meter Europe | PO Box 341442 | Dubai Silicon Oasis, Head Quarter Building, Wing C, Office #C209 | Dubai / UAE | +971-4-371 2503
Czech Republic | Badger Meter Czech Republic s.r.o. | Mařikova 2082/26 | 621 00 Brno, Czech Republic | +420-5-41420411
Slovakia | Badger Meter Slovakia s.r.o. | Racianska 109/B | 831 02 Bratislava, Slovakia | +421-2-44 63 83 01
Asia Pacific | Badger Meter | 80 Marine Parade Rd | 21-06 Parkway Parade | Singapore 449269 | +65-63464836
China | Badger Meter | 7-1202 | 99 Hangzhong Road | Minhang District | Shanghai | China 201101 | +86-21-5763 5412