User Manual

Read and save these instructions.

HEAT RECOVERY VENTILATORS

MODELS:

1000 HE

HE 1.3

2000 HE

HE 1.8

3000 HE

HE 2.6

3055 Compact

5585 Compact



VB0021



7 72371 05969 6

VVI, 550 Lemire Blvd., Drummondville, Qc, Canada
J2C 7W9

09/2004

#02053

Congratulations!

You have made an excellent choice! The operating principle of your Heat Recovery Ventilator will protect your house and give you personal comfort you have never known before.

We have prepared this Operating Guide especially for you. Please read it carefully to ensure you obtain full benefit from your Heat Recovery Ventilator unit. Over the coming months, you will increasingly appreciate the feeling of living in a more comfortable house.

Please take note that this manual uses the following symbols to emphasize particular information:

WARNING

Identifies an instruction which, if not followed, might cause serious personal injuries including possibility of death.

CAUTION

Denotes an instruction which, if not followed, may severely damage the unit and/or its components.

NOTE: Indicates supplementary information needed to fully complete an instruction.

We welcome any suggestions you may have concerning this manual and/or the unit, and we would appreciate hearing your comments on ways to better serve you. Please forward all correspondence to us at the address indicated on the product registration card included with this manual.

CAUTION

Make sure at all times that the outside hoods are free from any snow during the winter season. It is important to check your unit during a big snow storm, so it doesn't draw in any snow. If this is the case, please operate the unit in the circulation mode, or OFF mode, for a few hours.

Do not use your HRV during construction or renovation of your house or when sanding drywall. This type of dust may damage your system.

Since the electronic control system of the unit is incorporated with a microprocessor, it may not operate correctly because of external noise or very short power failure. If this happens, unplug the unit and wait approximately 10 seconds. Then, plug the unit in again.

Table of contents

1.0	Functions of your HRV	1
1.1	Air Exchange	1
1.2	Heat Recovery	1
1.3	Circulation	2
2.0	Diagrams of air flows	3
3.0	Description of unit	5
4.0	Operating the Wall Control	7
4.1	Basic and Venta Controls	8
4.2	Electro and Supra Controls	9
4.3	Ultima Control	10
5.0	Maintenance	11
5.1	Regular Maintenance	11
5.2	Annual Maintenance	12
6.0	Troubleshooting	13

1.0 Functions of your HRV

Your Heat Recovery Ventilator eliminates the problems of excessive humidity by exhausting stale and humid air to the outside and by drawing in fresh air. The unit offers superior air quality and fresh air sensation, an important factor to overall comfort, by eliminating the accumulation of pollutants and humidity.

The unit also comes equipped with a heat recovery core which reduces ventilating costs in winter.

The Heat Recovery Ventilator is a Ventilation system which carries out three main operations:

1.1 Air Exchange

The unit exhausts stale and humid air from the house and replaces it with fresh air from the outside.

MODELS	RATES
1000 HE / HE 1.3 / 3055 Compact	30 to 60 l/s (65 to 130 cfm)
2000 HE/ HE 1.8	55 to 93 l/s (115 to 197 cfm)
5585 Compact	55 to 92 l/s (117 to 195 cfm)
3000 HE / HE 2.6	85 to 141 l/s (180 to 300 cfm)

1.2 Heat Recovery

During winter, the unit recovers the heat contained in the stale air before it is exhausted, and transfers it to the fresh air drawn from the outside (reverse process in summer).

Example: (in winter)

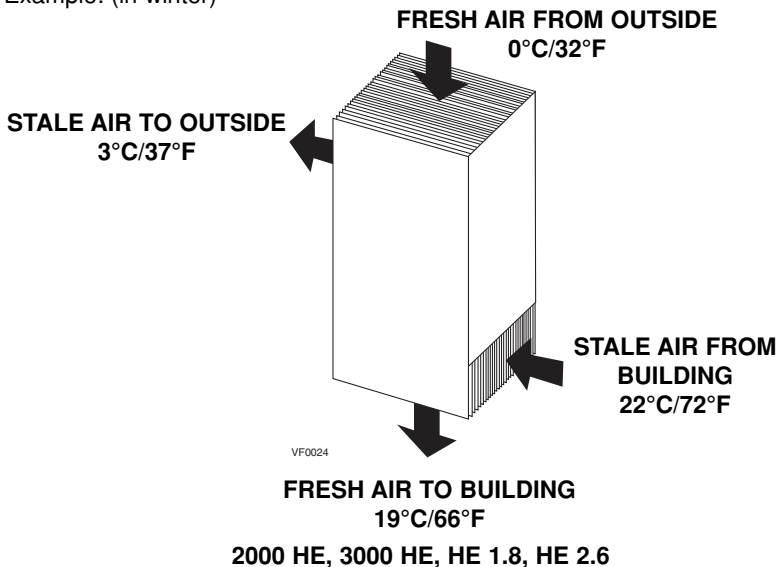

1.0 Functions of your HRV (cont'd)

1.2 Heat Recovery (cont'd)

Example: (in winter)

**STALE AIR TO
OUTSIDE
4°C/39°F**

**FRESH AIR TO
BUILDING
18°C/64°F**

**FRESH AIR
FROM OUT-
SIDE 0°C/32°F**



**STALE AIR
FROM BUILDING
22°C/72°F**

1000 HE, HE 1.3, 3055 Compact, 5585 Compact

1.3 Circulation (available with ULTIMA control only)

During the circulation mode, when the selected level of humidity is reached, the unit stops to exchange air with the exterior. Continuous circulation is thus undertaken inside the home and insures the purification of the ambient air. A mechanical filter traps the large dust particles (those visible to the eye).

2.0 Diagrams of Air Flows

The direction of the air flow is indicated in each of the following diagrams. Please note that the stale air never mixes with the fresh air.

MODELS

1000 HE, HE 1.3, 3055 Compact, 5585 Compact

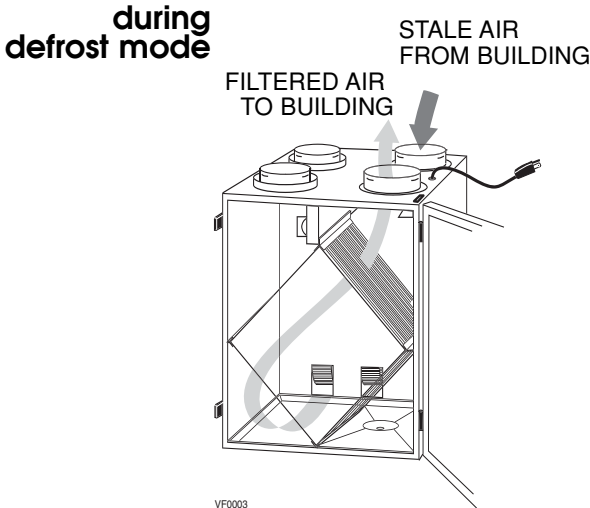
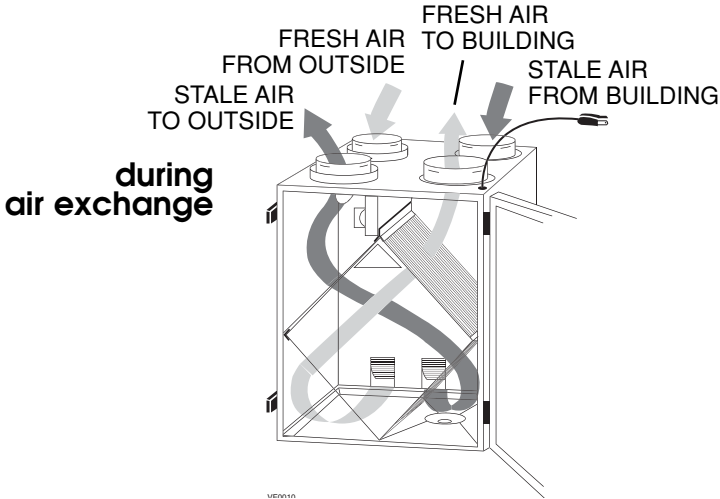

2.0 Diagrams of Air Flows (cont'd)

MODELS

2000 HE, 3000 HE, HE 1.8, HE 2.6

during
air exchange

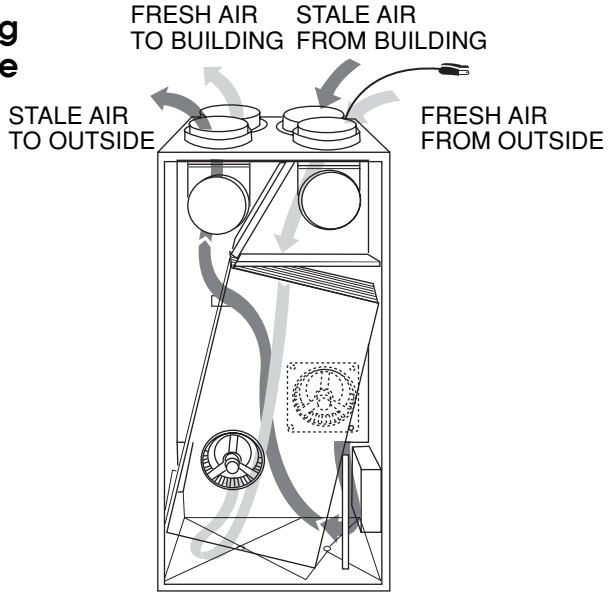

VF0025

during circulation
and defrost

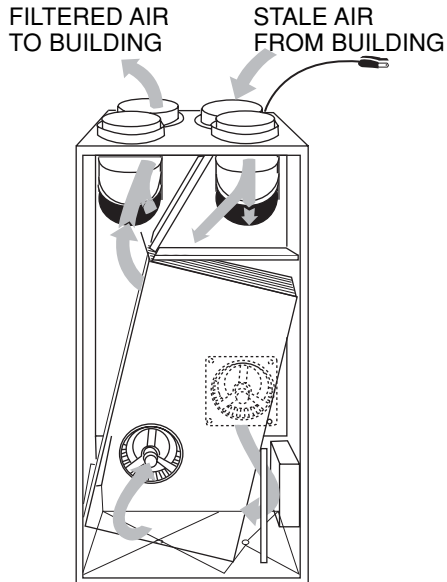

VF0002

3.0 Description of the Unit

- 1) **Stale air intake port:** is connected to the registers located in the larger rooms of the house.
- 2) **Fresh air port:** brings fresh air from the outside into the unit.
- 3) **Exhaust port:** exhausts stale air to the outside, after the air has transferred its heat inside the heat recovery core.
- 4) **Distribution port:** distributes fresh air into the house, after it has absorbed the heat of the stale air in the heat recovery core.
- 5) **Foam filter:** traps the dust contained in the air and prevents the heat recovery core from becoming obstructed.
- 6) **Heat recovery core:** is a counterflow type for 2000 HE, 3000 HE, 1.8 HE, 2.6 HE models and is a crossflow type for the other models. It transfers the heat between the two air streams.
- 7) **Blowers:** draw fresh air from the outside and exhaust stale air to the outside. The blower wheels are driven by two motors for 2000 HE, 3000 HE, 1.8 HE, 2.6 HE models. The other models have just one motor.
- 8) **Capacitor:** is indispensable to proper motor operation.
- 9) **Condensation tray:** is used to capture the water produced during heat transfer and defrost. (in cold climate)
- 10) **Drainage tube:** is connected to the condensation tray and serves to drain the water within.
- 11) **Electronic control circuit:** located inside the electrical box, insures proper operation of the unit.
- 12) **Automatic defrost unit:** consists of one damper actuator, dampers and the related controls. The defrost cycle is electronically controlled in response to the outside temperature (-5°C [23°F]) to -40°C [-40°F]) and will increase in frequency as the temperature decreases. Its duration is of 5 or 6 minutes according to models.
- 13) **Control Connector:** located inside the electrical box, allows to connect the control and override switch as a timer, a dehumidistat or a switch.
- 14) **Electrical cord:** for 120V electrical supply.

3.0 Description of the Unit (cont'd)

MODELS
1000 HE, HE 1.3,
3055 Compact,
5585 Compact

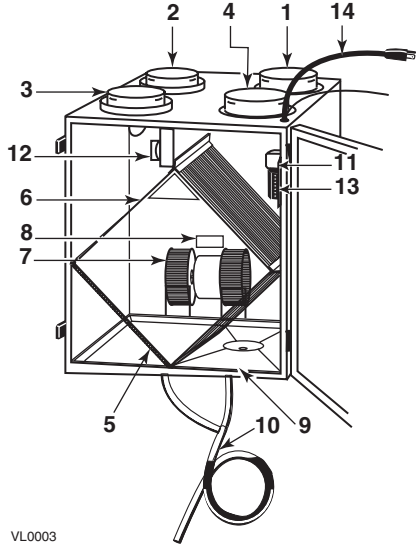

VL0003

MODELS
2000 HE, 3000 HE,
HE 1.8, HE 2.6

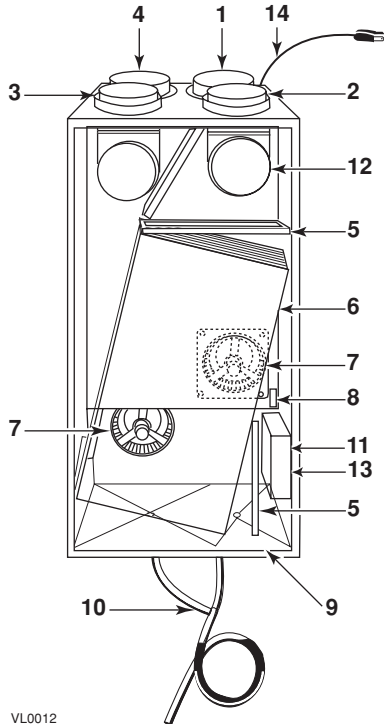

VL0012

4.0 Operating the Wall Controls

The following illustrations show the main controls. Refer to next pages for operating instructions.

1000 HE
2000 HE
3000 HE

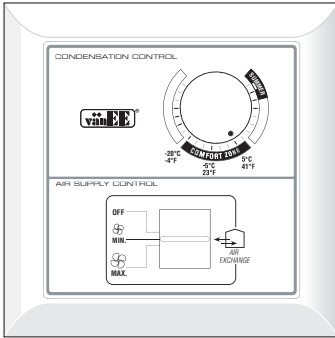

VC0035

BASIC

HE 1.3, HE 1.8, HE 2.6
3585 Compact
5585 Compact

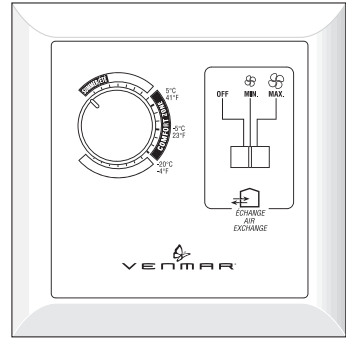

VC0010

VENTA

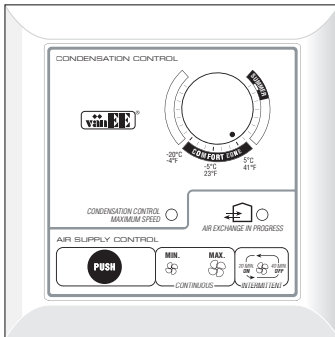

VC0036

ELECTRO

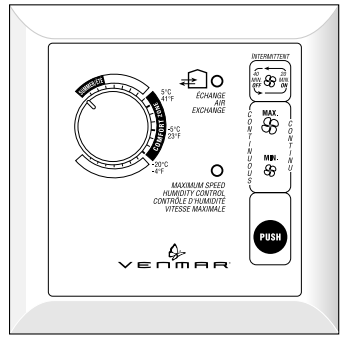

VC0011

SUPRA

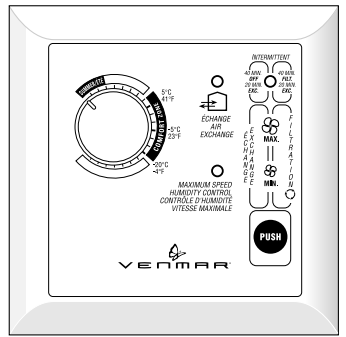

VC0013

ULTIMA

4.0 Operating the Wall Controls (cont'd)

4.1 Basic and Venta Controls

Purpose: To adjust air supply and select desired indoor humidity level.

ADJUSTING AIR SUPPLY CONTROL

- 1) **Select** speed “MIN.” or “MAX.” using slide switch.
 - When “MIN.” (minimum speed) is selected, if the knob is set above the click, the unit will exchange in low speed with the outside and if it is set below the click, the unit will exchange on high speed with the outside until the desired humidity level has been reached.
 - When “MAX.” (maximum speed) is selected, the unit will exchange on high speed with the outside either if the knob is set below or above the click.
- 2) To **turn off the unit**, slide the switch at the “OFF” position.

ADJUSTING HUMIDITY CONTROL

Setting during the summer months:

During this period, unless being afflicted with breathing problems, using the humidity control is unnecessary. Set the slide switch to “OFF”. (Do not exchange in day time; exchange at night time, if cool outside, or if it is not raining.)

Setting during the fall, winter and spring months:

(When condensation appears on windows)

- 1) Determine the humidity level in your house (bring the knob counterclockwise to its maximum position, then bring it back clockwise slowly until you hear a “click”).

CAUTION

Do not select a temperature below -20°C (-4°F). This could lead to excessive dryness in the air causing discomfort for the occupants.

- 2) Set the knob to one line under this temperature level or “click”.

It is possible (and normal) to experience condensation on your windows when drastic changes in temperature happen (for example: -5°C [23°F] to -20°C [-4°F]). In that case, we suggest waiting a few days to allow the situation to stabilize.

4.0 Operating the Wall Controls (cont'd)

4.2 Electro and Supra Controls

Purpose: To adjust air supply and select desired indoor humidity level.

ADJUSTING AIR SUPPLY CONTROL

- 1) **Select** speed “MIN.,” “MAX.” or INTERMITTENT using the push button.
 - When “MIN.” (minimum speed) is selected, if the knob is set above the click, the unit will exchange in low speed with the outside and if it is set below the click, the unit will exchange on high speed with the outside until the desired humidity level has been reached.
 - When “MAX.” (maximum speed) is selected, the unit will exchange on high speed with the outside either if the knob is set below or above the click.
 - When “INTERMITTENT” is selected, the unit will exchange with the outside on low speed (or on high speed if the knob is set below the click), during 20 minutes per hour.

NOTE: When INTERMITTENT signal is flashing, this means you have to clean your filters.

- 2) To **turn off the unit**, activate the push button once again.

ADJUSTING HUMIDITY CONTROL

Setting during the summer months:

During this period, unless being afflicted with breathing problems, using the humidity control is unnecessary; turn off the unit. (Do not exchange in day time; exchange at night time, if cool outside, or if it is not raining.)

Setting during the fall, winter and spring months:

(When condensation appears on windows)

- 1) Determine the humidity level in your house (bring the knob counterclockwise to its maximum position, then bring it back clockwise slowly until you hear a “click”).

CAUTION

Do not select a temperature below -20°C (-4°F). This could lead to excessive dryness in the air causing discomfort for the occupants.

- 2) Set the knob to one line under this temperature level or “click”.
It is possible (and normal) to experience condensation on your windows when drastic changes in temperature happen (for example: -5°C [23°F] to -20°C [-4°F]). In that case, we suggest waiting a few days to allow the situation to stabilize.

4.0 Operating the Wall Controls (cont'd)

4.4 Ultima Control

Purpose: To adjust air supply and select desired indoor humidity level.

ADJUSTING AIR SUPPLY CONTROL

- 1) **Select** speed “MIN.,” “MAX.” or INTERMITTENT using the push button.
 - When “MIN.” (minimum speed) is selected, if the knob is set above the click, the unit will exchange in low speed with the outside and if it is set below the click, the unit will exchange on high speed with the outside until the desired humidity level has been reached. (Green indicator is for exchange at low speed and red indicator is for circulation at low speed).
 - When “MAX.” (maximum speed) is selected, the unit will exchange on high speed with the outside either if the knob is set below or above the click. (Green indicator is for exchange at high speed and red indicator is for circulation at high speed)
 - When “INTERMITTENT” is selected, the unit will exchange with the outside on low speed (or on high speed if the knob is set below the click), during 20 minutes per hour. (Green indicator is for 20 min. exchange at low speed and 40 min. OFF and red indicator is for 20 min. exchange at low speed and 40 min. of circulation at high speed)

NOTE: When INTERMITTENT signal is flashing, this means you have to clean your filters.

- 2) To **turn off the unit**, activate the push button once again.

ADJUSTING HUMIDITY CONTROL

Setting during the summer months:

During this period, unless being afflicted with breathing problems, using the humidity control is unnecessary; turn off the unit. (Do not exchange in day time; exchange at night time, if cool outside, or if it is not raining.)

Setting during the fall, winter and spring months:

(When condensation appears on windows)

- 1) Determine the humidity level in your house (bring the knob counterclockwise to its maximum position, then bring it back clockwise slowly until you hear a “click”).

CAUTION

Do not select a temperature below -20°C (-4°F). This could lead to excessive dryness in the air causing discomfort for the occupants.

- 2) Set the knob to one line under this temperature level or “click”.

It is possible (and normal) to experience condensation on your windows when drastic changes in temperature happen (for example: -5°C [23°F] to -20°C [-4°F]). In that case, we suggest waiting a few days to allow the situation to stabilize.

5.0 Maintenance

WARNING

Risk of electric shock. Before performing any maintenance or servicing, always disconnect the unit from its power source.

5.1 Regular Maintenance

- 1) The motors are factory lubricated for life. Lubricating the bearings is not recommended.

CAUTION

Because the unit is suspended, two people are recommended to remove or install the heat recovery core.

Do not hold the heat recovery core using its plastic extrusions as handles.

- 2) The heat recovery core must be handled with care. We recommend that it be washed once a year, following the season of most intense use, in order to insure maximum efficiency of the plastic partitions.

Allow the heat recovery core to soak for 3 hours in a solution of warm water and mild soap. Rinse under a heavy stream of water.

CAUTION

Hot water and a strong detergent will damage the heat recovery core.

- 3) The air filters are washable. Under normal conditions, we recommend that they be washed every 3 months.
 - Use a vacuum cleaner to remove the heaviest portion of accumulated dust. Then wash in hot water.
- 4) Regularly check the screen on the exterior intake hood and clean when necessary. Also check during very cold weather because ice may grow on the screen located at the exterior intake hood.

5.0 Maintenance (cont'd)

5.2 Annual Maintenance

NOTE: Ask your installer for an annual service contract.

Annual service should include:

- 1) Cleaning filters, heat recovery core and the exterior air intake/exhaust hood.
- 2) Cleaning the wheels and the blower blades.
- 3) Cleaning the condensation tray with soapy water (make sure that the drain is not clogged).
- 4) Running the system and checking the different operating modes.
- 5) Measuring and calibrating rates of flow.

6.0 Troubleshooting

	TYPES OF PROBLEM	TRY THIS...
1	Nothing works.	<ul style="list-style-type: none">• Check if the unit is plugged in.• Check if the unit is receiving power from the house circuit breaker.
2	Condensation on windows.	<ul style="list-style-type: none">• Adjust the humidity control knob as per instructions (see Section 4).• Operate the unit at maximum speed during activities generating excess humidity (family gatherings, extra cooking, etc.).• Leave curtains half-open to allow air circulation on windows.• Store wood in a closed room with a dehumidifier or have the room well ventilated with outside air or store the wood outside.• Do not adjust the thermostat of your heating system below 18°C (64°F).
3	Air too dry.	<ul style="list-style-type: none">• Do not adjust your humidity control below -20°C (-4°F).• Operate the unit at low speed.• Temporarily stop air exchange.• Temporarily use a humidifier.
4	Air too cold at the air supply grille.	<ul style="list-style-type: none">• Make sure the stale air exhaust hood, outside the house, is not blocked.• Operate the unit at low speed.• Have the system balancing checked.• Have the unit defrosting system checked.• Install a duct heater.