



IMPRESSA S85

Instructions for use

I
M
P
R
E
S
S
A



Legend:

- **DISPLAY** DISPLAY: serves as information.
- **DISPLAY** **DISPLAY**: please follow the instructions shown.

 = Note

 = Important

 = Tip

JURA Elektroapparate AG, CH-4626 Niederbuchsiten,
Internet <http://www.jura.com>



Fig. 1



Fig. 2



Fig. 3



Fig. 4

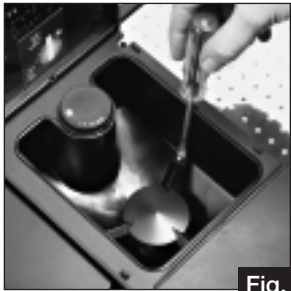

Fig. 5

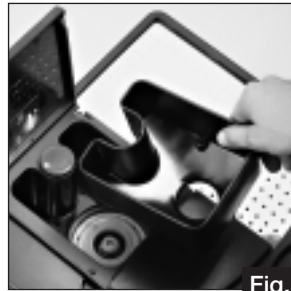

Fig. 6

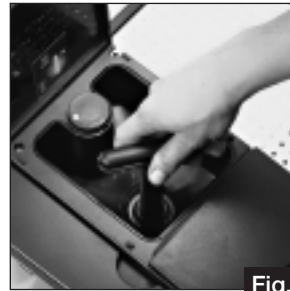

Fig. 7

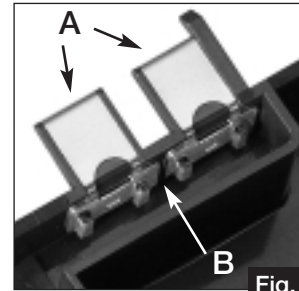

Fig. 8

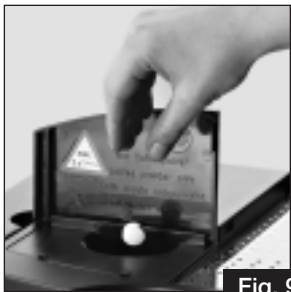

Fig. 9



Fig. 10

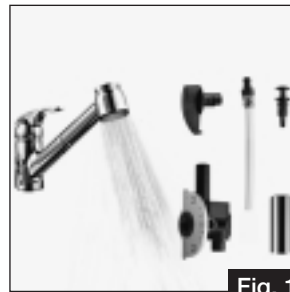
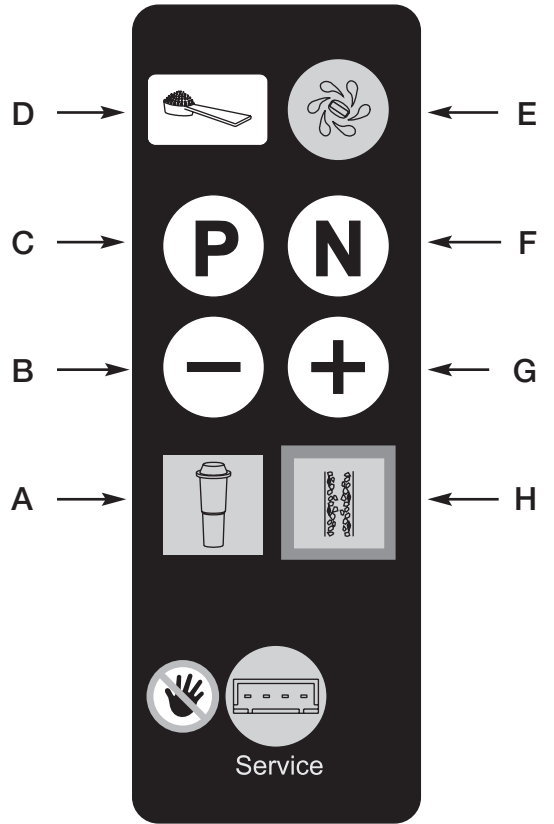
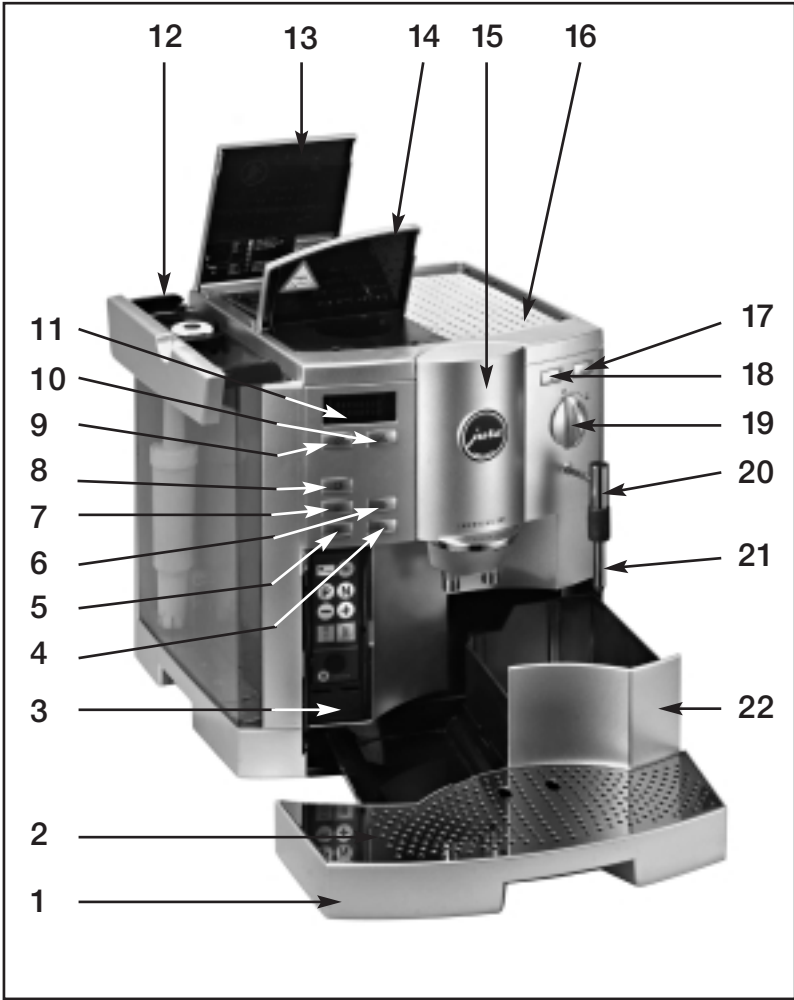

Fig. 11



Fig. 12



Operating elements JURA Impressa S85

- 1 Drip tray / residual water container
- 2 Drip tray cover
- 3 Cover for programming keys
- 4 Coffee key for 2 normal cups
- 5 Coffee key for 1 normal cup
- 6 Coffee key for 2 small cups
- 7 Coffee key for 1 small cup
- 8 Key for special coffee
- 9 ON/OFF switch
- 10 Rinsing key
- 11 Display dialogue system
- 12 Water tank with carrying handle
- 13 Cover for bean container and aroma protection lid
- 14 Cover for pre-ground coffee filler funnel
- 15 Height-adjustable coffee-spout
- 16 Cup warming tray
- 17 Selector key for steam
- 18 Selector key for hot water
- 19 Selector switch for coffee or hot water/steam
- 20 Pivoting nozzle for hot water/steam
- 21 Replceable steam/frothing nozzle
- 22 Container for coffee grounds

Programming keys

- A Change filter
- B Back-setting of criteria / changing of memory indications downwards
- C Open program
- D Selector switch for pre-ground coffee
- E Key for cleaning program
- F Correction of program / close
- G Forward-setting of criteria / changing of memory indications up-wards
- H Key for decalcifying program

Table of contents

JURA Impressa S85

1. Description	page 7	13.1 Programming POWDER QUANTITY	page 13
2. Safety instructions	page 7	13.2 Programming coffee temperature	page 13
2.1 Warnings	page 7	13.3 Programming water quantity	page 13
2.2 Safety precautions	page 7	13.4 Programming FILTER	page 14
3. Check before use	page 8	13.5 Programming WATER HARDNESS	page 14
3.1 Checking mains voltage	page 8	13.6 Programming ECONOMY MODE	page 14
3.2 Checking fuse	page 8	13.7 Programming TIMER CLOCK	page 14
3.3 Adding coffee beans	page 8	13.8 Programming automatic switch on time	page 15
3.4 Adjusting grinder	page 8	13.9 Programming automatic switch off time	page 15
4. Preparing machine	page 8	13.10 Cup counter	page 15
5. Rinsing the machine	page 9	13.11 Programming language selection	page 15
6. Adjusting for water hardness	page 9	13.12 Program key (N)	page 15
7. Use of CLARIS plus filter cartridges	page 9	14. Care and maintenance	page 15
7.1 Placing filter	page 9	14.1 Fill water	page 15
7.2 Replacing of filter	page 10	14.2 Empty grounds container	page 16
8. Drawing off coffee	page 10	14.3 Empty drip tray	page 16
8.1 Drawing off powder coffee	page 11	14.4 Fill beans	page 16
9. Drawing off hot water	page 11	14.5 Removing foreign objects	page 16
10. Using steam	page 11	14.6 Clean machine	page 16
11. Drawing off steam using the		14.7 Unit calcified	page 16
Profi-Auto-Cappuccino/Caffè Latte (option)	page 12	14.8 Cleaning metal contacts	page 16
11.1 Connecting the Profi-Auto-Cappuccino/ Caffè Latte to your IMPRESSA S85	page 12	14.9 General cleaning instructions	page 17
11.2 Drawing off cappuccino and hot milk using Profi-Auto-Cappuccino/Caffè Latte	page 12	15. Cleaning	page 17
11.3 Cleaning the Profi-Auto-Cappuccino/Caffè Latte	page 12	16. Decalcifying	page 17
12. Switching off machine	page 13	16.1 Decalcifying coffee sector	page 18
13. Programming	page 13	16.2 Decalcifying water sector	page 18
		17. Disposal	page 19
		18. Tips for a perfect coffee	page 19
		19. Messages	page 20
		20. Problems	page 22
		21. Legal information	page 23
		22. Technical specifications	page 23

Important information for the user

Thank you for choosing this JURA product.

Please study these instructions carefully before using your new machine and keep them in a safe place for easy reference in the future.

Should you require further information or should particular problems occur that are not dealt with in these operating instructions in sufficient detail for you, then please ask your local dealer for the information you require or contact JURA Elektroapparate AG directly.

1. Description

This fully-automatic espresso/coffee machine impresses because of its user-friendly operational mode and its ingenious technology. In just one brewing-process it can prepare 1 or 2 cups of excellent, professional-quality espresso/coffee with guaranteed froth. Originating from professional sectors and having been refined and further developed by JURA, the Intelligent Pre Brew Aroma System (I.P.B.A.S[®]) ensures full coffee aroma. The Impressa S85 enables you to adapt the resulting coffee to your personal taste due to the possibility of programming coffee-powder and water quantities as well as the brewing temperature.

The machine works fully-automatically at the press of a key. A decoded text-display shows messages and simplifies the operation considerably. Because of the integrated rinsing, cleaning and decalcifying programs care and maintenance is quick and easy.

2. Safety instructions

2.1 Warnings

- Children are unaware of the dangers that electrical machines represent. Therefore children should never be left unsupervised with electrical machines.
- This machine should only be used by people who have read and understood the operating instructions.
- Never use a faulty machine or one with a damaged power cable.
- Never immerse the machine in water.

2.2 Safety precautions

- Never expose the machine to the effects of rain, snow or frost and never operate it with wet hands.
- Place your machine on a solid level surface. Never leave it on a surface that is warm or hot (hob etc.). Choose a location that is inaccessible for children or pets.
- Remove plug from power socket if an absence for a longer period of time (holidays etc.) is planned.
- Always remove plug from power socket before cleaning.
- When removing plug from power socket, never tug on the cord or on the machine itself.
- Never repair or open the machine yourself. All repairs should be performed by authorised service centres only using original JURA spare parts and accessories.
- The machine is connected to the mains power socket via an electric cable. Ensure that no-one trips over this cable and pulls down the machine. Keep children and animals at a distance to the machine.
- Never put the machine or even parts of it in the dishwasher.
- To prevent overheating place the machine in an airy place.

- If using acidic decalcifying agents be sure to immediately remove any splashes and drops from delicate surfaces, especially natural stone and wooden surfaces, or take corresponding precautions.

3. Check before use

3.1 Checking mains voltage

The machine is set for the correct voltage before leaving our factory. Ensure that your mains voltage corresponds to the details quoted on the rating plate attached to the bottom of the machine.

3.2 Checking fuse

The machine is designed for a current of 10 amps. Check that an appropriate fuse is fitted.

3.3 Adding coffee beans

-  To ensure that your machine will work perfectly for a long time and to avoid damage, please note that the grinding gear of your JURA coffee machine is not suitable for coffee beans which were treated, during or after roasting, with additives (e.g. sugar). Such coffee blends may damage the grinding gear. Any repair costs resulting from the use of such blends are not covered by warranty.
- Lift up cover of the bean container (13) and remove aroma protection lid.
- Clean out any dirt or foreign object from the bean container.
- Fill the grinder container with coffee beans, replace aroma protection lid and close the cover.

3.4 Adjusting grinder



You can adjust the grinder to the roast of your coffee. We recommend the following:

for a light roast → a finer adjustment
for a dark roast → a coarser adjustment

- Open the cover of the bean container (13).
- To adjust grinding turn selector switch (Fig. 1) to the desired position.
- You have the following possibilities:
 - the smaller the dots, the finer the grinding
 - the bigger the dots, the coarser the grinding

 The grinding grade should only be adjusted while the grinder is working.

4. Preparing machine

- Switch your machine on by pressing ON/OFF key . The machine adjusts fully-automatically to the starting position.
- **DISPLAY** FILL WATER
- Remove water tank and rinse well with clear tap-water.
- Fill water tank and replace. Make sure that tank engages well. (Abb.).
- **DISPLAY** PLEASE WAIT
- **DISPLAY** RINSE UNIT
- Place a container under the coffee-spout (15) and press rinsing key .
- **DISPLAY** UNIT RINSING
- **DISPLAY** COFFEE READY

5. Rinsing the machine

■ **DISPLAY** RINSE UNIT

- Place an empty cup under the coffee-spout (15).
- Press rinsing key .



If the machine has been switched off and has already cooled down it will be necessary to carry out this rinsing function when the machine is switched on again.

After switching off the machine, the rinsing sets off automatically.

6. Adjusting for water hardness

The water is heated inside the machine. With use, this leads to calcium deposits (furring) forming on the machine. This will be automatically indicated on the display.

For this reason, it is necessary to adjust the machine to the hardness of your local water before you use it for the first time. Use the enclosed test-sticks for this purpose.



1° water hardness on the German scale represents 1.79° on the French scale.

The machine has got 5 hardness settings to choose from. While adjusting the chosen grade is shown on the display.

The symbols on the display mean:

HARDNESS

LEVEL -- water hardness function is switched off

HARDNESS German water hardness 1 – 7°

LEVEL 1 French water hardness 1.79 – 12.53°

HARDNESS German water hardness 8 – 15°

LEVEL 2 French water hardness 14.32 – 26.85°

HARDNESS German water hardness 16 – 23°

LEVEL 3 French water hardness 28.64 – 41.14°

HARDNESS	German water hardness	24 – 30°
LEVEL 4	French water hardness	42.96 – 53.7°

The machine is adjusted to hardness level 3 before it leaves the factory. You can alter this setting by following the instructions below:

- Switch the machine on by pressing ON/OFF key . The machine adjusts fully-automatically to the starting position.

■ **DISPLAY** PLEASE WAIT



- Open cover (3) and press key , until you hear an acoustic signal

■ **DISPLAY** PRESS KEY / POWDER QUANTITY

- Press key  several times until the following message appears:

■ **DISPLAY** HARDNESS LEVEL 3

- By pressing key  you can hear an acoustic signal, the set hardness level flashes

- You can alter the hardness level by pressing key  or . After setting, press key  once again to confirm. An acoustic signal can be heard.

- Press key  to return to stand-by-status.









7. Use of CLARIS plus filter cartridges



Under proper implementation of CLARIS plus filter cartridges, decalcifying of the machine becomes unnecessary. For further information, please read the brochure “Claris. Tough to calcium deposits, gentle to your coffee machine”.

7.1 Placing filter

- Pull up cartridge mounting. Pressing lightly, place the filter cartridge in the water tank (Fig. 2).
- Pull down cartridge mounting, until it engages audibly.
- Fill water tank with cold, fresh tap-water and replace it.

- Switch the machine on by pressing key  ON/OFF.
- Open front cover (3) and press key  until you hear an acoustic signal.
- **DISPLAY PRESS KEY / POWDER QUANTITY**
- Press key  several times until the following message appears:
- **DISPLAY FILTER NO**
- By pressing key  you can hear an acoustic signal.
- **DISPLAY NO** flashes
- You can alter the setting by pressing key  or .
- **DISPLAY YES** flashes
- To confirm press key . An acoustic signal can be heard.
- **DISPLAY RINSE FILTER / OPEN TAP**
- Place a sufficiently large container (approx. 1 litre) under the pivoting nozzle (20). Turn selector switch for coffee or hot water/steam (19) to position .
- **DISPLAY PLEASE WAIT / FILTER RINSING**
- **DISPLAY CLOSE TAP** (the system gives off steam)
- **DISPLAY FILTER YES**
- Press key .
- **DISPLAY COFFEE READY**



 The water might be slightly discoloured (this is not damaging to the health).

7.2 Replacing of filter

After drawing off 50 litres the filter loses its effect.



- **DISPLAY REPLACE FILTER**



If only a little water is drawn off the filter should be changed every 2 months. However no message will appear on the display. You will find a special turntable on the cartridge mounting to set the replacement date.

- Empty water tank and pull up cartridge mounting. Pressing lightly, place the filter cartridge in the water tank (Fig. 2).
- Pull down cartridge mounting, until it engages audibly.
- Fill water tank with cold, fresh tap-water and replace it.
- Switch the machine on by pressing key ON/OFF .
- Open front cover (3) and press key , until you hear an acoustic signal.
- **DISPLAY RINSE FILTER / OPEN TAP**
- Place a sufficiently large container (approx. 1 litre) under the pivoting nozzle (20). Turn selector switch for coffee or hot water/steam (19) to position .
- **DISPLAY PLEASE WAIT / FILTER RINSING**
- **DISPLAY CLOSE TAP** (the system gives off steam)
- **DISPLAY COFFEE READY**





 The water might be slightly discoloured (this is not damaging to the health).

8. Drawing off coffee



- Switch the machine on by pressing key ON/OFF .
- **DISPLAY PLEASE WAIT**
- **DISPLAY RINSE UNIT**
- Put an empty cup under the coffee-spout (15) and press rinsing key .
- **DISPLAY UNIT RINSING**
- **DISPLAY COFFEE READY**
- Put 1, respectively 2 cups under the coffee-spout and press the required key. The pre-brew system (I.P.B.A.S[®]) moistens the coffee powder, briefly interrupts the flow and then starts the real brewing process.



-  You can interrupt the flow of coffee at any time by simply pressing any of the coffee keys.
-  To obtain a perfect head of froth adjust the coffee-spout (15) to the size of your cups (Fig. 3).



8.1 Drawing off powder coffee

- Open cover (3)
- Press selector key for pre-ground powder coffee .
- **DISPLAY FILL POWDER**
- Now put 1 or 2 level measuring spoons of pre-ground coffee into the pre-ground powder funnel (14).
- Put 1, respectively 2 cups under the coffee-spout and press the required key.
-  Never use soluble instant coffee or quick coffee. Only use coffee powder from freshly ground beans or pre-ground vacuum-packed coffee. **Never fill the funnel with more than 2 portions of coffee powder at a time. The powder funnel is not intended as a storage container.**
-  If selector key  is pressed by mistake this can be corrected by pressing one of the coffee keys.

9. Drawing off hot water

-  Install the hot water nozzle (see Fig. 3) to obtain perfect water flow. Do not replace the replaceable hot water nozzle (21) directly after drawing off water, because the nozzle is hot after the draw-off operation.
-  At the start of the water draw-off operation there can be splashing. Avoid direct contact with the skin!
- Press selector key for hot water . Wait until the flashing of the lamp turns into a constant light.

- Put a cup under the pivoting nozzle and turn selector switch for coffee or hot water / steam (19) to the symbol . The machine will now deliver hot water.
- **DISPLAY WATER SUPPLIED**
- To stop this process turn selector switch for hot water / steam (19) back to the symbol . The cup should only be removed when the hot water has stopped its flow.

-  The machine has a stand-by-status for hot water. If you want to alternate between drawing off coffee and hot water, the selector switch for hot water can be left turned on . If you draw off hot water only once, then the selector switch for hot water should be turned off by pressing the selector key  anew.

-  When hot water is first drawn off, there is a possibility of spattering. The pivoting nozzle becomes hot. Avoid direct contact with the skin.

10. Using steam

-  Install the replaceable steam/frothing nozzle (Fig. 4). This is included in your Welcome Pack. Do not replace the replaceable steam/hot water nozzle (21) directly after drawing off steam, because the nozzle is hot after the draw-off operation.

Steam can be used for heating up liquids as well as for frothing up milk for cappuccinos.

To heat up liquids remember to push the frothing nozzle (21) up. For frothing up liquids push the frothing nozzle (21) down (Fig. 4).

- Press selector key for steam . Wait until the flashing of the lamp turns into a constant light.
- Put a cup under the pivoting nozzle (20).

- Immerse the frothing nozzle (21) into the milk you want to froth or into the liquid you want to heat up. Turn selector switch for coffee or hot water / steam (19) to the symbol ☞.
- To draw off steam open the steam/hot water draw-off valve (19).
- **DISPLAY** STEAM INTAKE
- To stop steam-function turn selector switch for coffee or hot water / steam (19) back to the symbol ☞.



After drawing off steam immediately draw off approx. 1dl of water and clean the outside of the nozzle with a cloth.



If you want to draw off steam several times, the selector key for steam can be left on. The drawing off of steam is on stand-by-status. If you draw off steam only once, then the selector switch for steam ☞ should be turned off by pressing the selector key anew.



When steam is first drawn off, there is a possibility of spattering. The pivoting nozzle becomes hot. Avoid direct contact with the skin.

11. Drawing off steam using the Profi-Auto-Cappuccino/Caffè Latte (option)



The Profi-Auto-Cappuccino/Caffè Latte is optionally available. Contact your authorized dealer.

11.1 Connecting the Profi-Auto-Cappuccino/Caffè Latte to your IMPRESSA S85

- Disassemble the replaceable hot water nozzle or the replaceable steam/frothing nozzle.
- Mount the Profi-Auto-Cappuccino/Caffè Latte (Fig. 10)
- Press one side of the hose into the opening behind the dial (Fig. 12)



The optionally available milk container can be used for sucking in milk.

11.2 Drawing off cappuccino and hot milk using Profi-Auto-Cappuccino/Caffè Latte

- Fill the milk container with milk or immerse the hose in the milk directly.
- Place a cup under the Profi-Auto-Cappuccino/Caffè Latte.
- Press selector key for steam ☞. Wait until the flashing of the lamp turns into a constant light.
- To draw off steam open the steam/hot water draw-off valve (19).
- **DISPLAY** STEAM INTAKE
- To stop steam-function turn selector switch for coffee or hot water / steam (19) back to the symbol ☞.
- For cappuccino turn the selector switch (1) (Fig. 12) to area (2).
- For hot milk turn the selector switch (1) (Fig. 12) to area (3).



To increase the heat turn the selector switch (1) (Fig. 12) to area + To reduce the heat, turn the selector switch to area -.

- Now place the cup with the cappuccino froth or the hot milk under the coffee spout and draw of the product of your choice.

11.3 Cleaning the Profi-Auto-Cappuccino/Caffè Latte



The Profi-Auto-Cappuccino/Caffè Latte must be cleaned after each draw-off operation.

- Fill water in a container and immerse the hose in it.
- Draw off steam until the water/steam mixture is clean.
- If necessary, disassemble the Profi-Auto-Cappuccino/Caffè Latte and thoroughly rinse the flow regulation with water (Fig. 11).



For proper cleaning, use the JURA Auto Cappuccino Cleaning Agent This is available at your authorized dealer. The instructions for use you'll find on the agent. Daily cleaning is recommended.

12. Switching off machine

When the machine is switched off, the rinsing program is automatically run again. Therefore place an empty container under the coffee-spout (15) and press ON/OFF key . When the rinsing water has run into the container, the machine powers down. Discard the water.



13. Programming

Before leaving our factory, the machine is adjusted to enable you to obtain coffee without any additional programming. In order to adapt the result to your personal taste, various settings can be programmed individually. The programming keys are located behind the front cover (3).





The following settings can be programmed:

- ▶ Powder quantity
- ▶ Brewing temperature
- ▶ Water quantity
- ▶ Filter
- ▶ Water hardness
- ▶ Economy mode
- ▶ Timer clock
- ▶ Automatic switch on time
- ▶ Automatic switch off time
- ▶ Supplies and cup counter
- ▶ Language selection





13.1 Programming POWDER QUANTITY

- Switch the machine on by pressing ON/OFF key .
- Press key  until you can hear an acoustic signal.
- **DISPLAY** POWDER QUANTITY / SELECT KEY
- Now press the key that you want to programme. Use the key for 1 cup only. The corresponding quantity for 2 cups is adjusted automatically by the machine after programming is finished.







■ **DISPLAY** POWDER
-II..... +

- The powder quantity can be selected by pressing keys  or  briefly.
- To store the new powder quantity in memory briefly press key .
- **DISPLAY** POWDER QUANTITY / SELECT KEY.
- You can go to the next setting by pressing key .

13.2 Programming coffee temperature

- **DISPLAY** TEMPERATURE COFFEE / SELECT KEY
- Now press the key that you want to programme.
- Select the required temperature (high or normal) by activating key  or .
- To store the new coffee temperature in memory briefly press key .
- **DISPLAY** TEMPERATURE COFFEE / SELECT KEY
- You can call up the next setting by pressing key .

13.3 Programming water quantity

- **DISPLAY** WATER QUANTITY / SELECT KEY
- Put a cup under the coffee-spout (15) and then press the key that you want to programme.
- **DISPLAY** The selected value is confirmed
- Now your machine prepares a coffee.
- **DISPLAY** ENOUGH COFFEE / PRESS KEY 
- **DISPLAY** OK?  -II..... +
- When the required water quantity is reached press key . You can call up the next setting by pressing key .
- There is an additional possibility to alter the water quantity anew. Press key  or  for this purpose.



- If you wish to draw another coffee to control the water quantity, press key again otherwise press key **P** briefly to store water quantity in memory.
- You can call up the next setting by pressing key **+**.

13.4 Programming FILTER

Please read chapter 7.1 “Placing filter”.

13.5 Programming WATER HARDNESS (only with setting FILTER NO)

- **DISPLAY** HARDNESS LEVEL 3
- Press key **P**
- By pressing key **+** or **-** briefly you can programme the water hardness level.
- Then press key **P** briefly to store the water hardness level in memory.
- You can call up the next setting by pressing key **+**.

 To determine the water hardness level please read chapter 6. “Adjusting for water hardness”.

13.6 Programming ECONOMY MODE

- **DISPLAY** ECONOMY MODE OFF
- Press key **P**
- **DISPLAY** ECONOMY (MODE OFF flashes)
- By briefly pressing key **+** or **-** you can programme the mode you would like.
- Then press key **P** briefly to store mode in memory
- You can call up the next setting by pressing key **+**.

 You can programme your machine to “economy mode”. In the setting ECONOMY MODE ON the steam heating-system is switched off. The heating for the cup warming tray is switched off too. If you want to draw off steam you need to press the steam key **☺**, warning lamps flash and your machine heats up.

After 10 minutes the steam heating-system switches off automatically. The warning lamps go out. By pressing the steam key anew, you return to stand-by-status for drawing off steam.

ECONOMY MODE OFF means that the stand-by-status for steam is set to 10 minutes and the heating for the cup warming tray is on. After 10 minutes the heating-system switches down to a stand-by temperature. By pressing the steam key anew, the machine returns to stand-by-status for drawing off steam.

13.7 Programming TIMER CLOCK

 A programming of the timer clock is necessary if an automatic switch on time is required.

- **DISPLAY** TIME --:--
- Press key **P**.
- By briefly pressing key **+** or **-** you can set the hours and then confirm by pressing key **P**.
- By briefly pressing key **+** or **-** you can set the minutes and then confirm by pressing key **P**.
- You can call up the next setting by pressing key **+**.

13.8 Programming automatic switch on time

 A programming of the timer clock is necessary if an automatic switch on is needed.

- **DISPLAY** UNIT ON --
- Press key **P**.
- By briefly pressing key **+** or **-** you can set the hours and then confirm by pressing key **P**.
- By briefly pressing key **+** or **-** you can set the minutes and then confirm by pressing key **P**.
- You can call up the next setting by pressing key **+**.

 To switch off the automatic timer proceed as follows:
Press key **P**
Press key **N**
DISPLAY UNIT ON —:—

13.9 Programming automatic switch off time

- **DISPLAY** OFF AFTER 5.0 HOURS
- Press key **P**
- By briefly pressing key **+** or **-** you can set the hours and then confirm by pressing key **P** (0.5 to 9.0 hours).
- You can call up the next setting by pressing key **+**.

13.10 Cup counter

- **DISPLAY** 200 SUPPLIED (TOTAL SUPPLIED)
- To obtain the information press the required key. The display will show you the number of times the function has been chosen.
- You can call up the next setting by pressing key **+**.

 It is not possible to call up hot water and steam supplies.

13.11 Programming language selection

- Press key **P**
- By briefly pressing key **+** or **-** call up the language desired and then confirm by pressing key **P**.
- By pressing key **N** you can leave the programming modus or you can call up the next setting by pressing key **+**.

13.12 Program key **N**

By using key **N** you can set back the following settings (powder quantity, coffee temperature, water quantity) to their original standard settings.

- **DISPLAY** COFFEE READY
- Press key **N** until you can hear an acoustic signal.

 If a mistake occurs while programming one of the above settings, just press key **N** and the chosen setting moves back to its original standard setting.

14. Care and maintenance

14.1 Fill water

- **DISPLAY** FILL WATER
- If this message shows on the display no more coffee can be drawn off. Top up water.

 The water tank should be rinsed and filled with fresh water daily. Only use fresh, cold water. Never top up with milk, mineral water or any other liquids. You can top up water without removing tank.

14.2 Empty grounds container

Coffee grounds are collected in the grounds container.

■ **DISPLAY** EMPTY GROUNDS

- If this message shows on the display no more coffee can be drawn off. It is necessary to empty the grounds container.
- Remove drip tray carefully as there is water in it.

 **Do not disconnect** the machine from power socket while you empty grounds.

14.3 Empty drip tray

■ **DISPLAY** EMPTY TRAY

- If this message shows on the display no more coffee can be drawn off. It is necessary to empty the drip tray.
- Remove drip tray carefully as there is water in it.

14.4 Fill beans

■ **DISPLAY** FILL BEANS

- Fill in beans as described in chapter 3.3.

 The message FILL BEANS will only disappear after drawing off a coffee. We recommend cleaning the bean container from time to time with a dry cloth before you refill beans. **Switch off** the machine for this purpose.

14.5 Removing foreign objects

- Switch off your machine by pressing ON/OFF  key.
- Remove plug from power socket.
- Open bean container (13) and remove the beans. The remaining beans can be removed with a vacuum cleaner.

- Loosen both screws in the bean container and then remove container (Fig. 5+6)
- Remove any remaining beans with a vacuum cleaner.
- Put the spanner on (Fig. 7).
- Now turn spanner anticlockwise until the foreign object loosens.
- Remove remaining powder with a vacuum cleaner.
- Replace bean container and fasten screws.

14.6 Clean machine

■ **DISPLAY** CLEAN UNIT

After coffee, etc., has been drawn off 220 times or after 180 rinsing programs have been run, the machine must be cleaned. You can continue to draw off coffee and hot water / steam. However we recommend that you clean the machine (as described in chapter 14) within the next few days.

■ **DISPLAY** CLEAN NOW

An acoustic signal indicates the need of an **immediate** cleaning.

14.7 Unit calcified

■ **DISPLAY** UNIT CALCED

The machine signals when decalcifying becomes necessary.

 Under the correct implementation of CLARIS plus filter cartridges, decalcifying of the machine becomes unnecessary. For further indications read Chapter 7 “Use of CLARIS plus filter cartridges”.

14.8 Cleaning metal contacts

■ **DISPLAY** EMPTY TRAY

To switch off this message you need to remove calcified deposits from the metal contacts. Proceed as follows:

- Rinse fastenings in groove (B) (Fig. 8) as well as the metal contacts (A) with hot water and some washing-up liquid. Then clean the fastenings in groove (B) as well as metal contacts with a brush.

14.9 General cleaning instructions

- Never use abrasive articles or corrosive chemicals to clean your machine.
- Wipe down the casing inside and out using a soft damp cloth.
- Clean the pivoting hot water / steam nozzle after every use.
- After warming milk, draw off some hot water to clean the pivoting nozzle inside.
- You can take off the pivoting nozzle for a thorough cleaning
- The water tank should be rinsed and filled with clean water daily.



 If you notice any furring in the water tank, this can be decalcified separately with a customary decalcifying agent. Remove the tank from the machine for this purpose.

 If a CLARIS plus filter cartridge is used, remove it beforehand.

15. Cleaning

The machine has an integrated cleaning program. The procedure lasts about 15 minutes. Please only use original JURA cleaning tablets: their formula is especially tailored to JURA coffee machines.

It is essential not to interrupt the process once it has been started.

- Switch on machine by pressing  key.
- Press key  until you can hear an acoustic signal.
- **DISPLAY EMPTY TRAY** (FILL WATER might show as well)



Put a sufficiently large container under the coffee-spout (15) in order to prevent cleaning liquid from running into the drip tray.

- **DISPLAY ADD TABLET (Fig. 9) / PRESS CLEANING**
- **DISPLAY UNIT CLEANING**
- **DISPLAY EMPTY TRAY**
- **DISPLAY RINSE UNIT**
- **DISPLAY COFFEE READY**



The powder funnel for pre-ground coffee should be cleaned after each cleaning process. Remove it from the machine , rinse it with hot tap water and replace it after drying.

16. Decalcifying

Your machine has an integrated decalcifying program (duration approx. 35 min.).

Please only use original JURA de-scaling tablets: their formula is especially tailored to JURA coffee machines.







Run the decalcifying program only after the machine has been switched off for at least 5 hours and has cooled down completely. The running decalcifying program must not be interrupted.



If using acidic decalcifying agents be sure to immediately remove any splashes and drops from delicate surfaces, especially natural stone and wooden surfaces, or take corresponding precautions.

In any case please wait until the filled decalcifying agent is used up and the tank is empty. Never top up the decalcifying agent.





16.1 Decalcifying coffee sector

- Remove and empty water tank.
- Replace empty water tank.
- Switch off your machine by pressing ON/OFF  key.
- Open cover (3).
- Press key  until you can hear an acoustic signal.
- **DISPLAY** EMPTY TRAY
- **DISPLAY** AGENT IN TANK
Pour 0.6 litres of water into a container and completely dissolve the contents of a blister pack (3 tablets). Then fill the mixture into the water tank.
- **DISPLAY** CHOOSE SECTOR / AGENT IN TANK / PRESS CALC
- Turn selector switch for coffee to the symbol .
- Press key .
- **DISPLAY** COFFEE SECTOR / UNIT DECALCIFYING
- Inside the machine the decalcifying agent is conducted to the drip tray.
- **DISPLAY** EMPTY TRAY
- **DISPLAY** FILL WATER
- **DISPLAY** PRESS CALC
- **DISPLAY** COFFEE SECTOR / UNIT DECALCIFYING
- Inside the machine the water is conducted to the drip tray.
- **DISPLAY** EMPTY TRAY / CLEAN CONTACTS
(please refer to chapter 14.8)
- **DISPLAY** PLEASE WAIT
- **DISPLAY** RINSE UNIT
- Place a container under the coffee-spout (15) and press rinsing key .

- **DISPLAY** UNIT RINSING
- **DISPLAY** COFFEE READY

16.2 Decalcifying water sector

This message will only appear if the unit is ready to draw off water or steam.

- Remove and empty water tank.
- Replace empty water tank.
- Switch off your machine by pressing ON / OFF  key.
- Open cover (3).
- Press key  until you can hear an acoustic signal.
- **DISPLAY** EMPTY TRAY
- **DISPLAY** AGENT IN TANK
Pour 0.6 litres of water into a container and completely dissolve the contents of a blister pack (3 tablets). Then fill the mixture into the water tank.
- **DISPLAY** AGENT IN TANK / CHOOSE SECTOR / PRESS CALC
- Place a container under the pivoting nozzle and turn selector switch for coffee or hot water/steam (19) to the symbol .
- Press key .
- **DISPLAY** UNIT DECALCIFYING / WATER SECTOR
- **DISPLAY** FILL WATER
Rinse water tank well and top it up with fresh tap water.
- **DISPLAY** PRESS CALC
- **DISPLAY** WATER SECTOR / UNIT DECALCIFYING
- **DISPLAY** CLOSE TAP
- **DISPLAY** RINSE UNIT
- **DISPLAY** UNIT RINSING
- **DISPLAY** COFFEE READY

17. Disposal

For correct disposal, you should return your coffee machine to your dealer, JURA service centre or JURA Elektroapparate AG.

18. Tips for a perfect coffee

Height adjustable coffee-spout

You can adjust the height of the coffee-spout to your cup sizes.

Grinding

Please refer to chapter 3.4 “Adjusting grinder”.

Pre-warm cups

You should warm cups in advance with hot water or steam. The smaller the quantity of coffee, the more important warming the cups is.

Sugar and cream

Warmth is lost by stirring the contents of the cup. Adding milk or cream from the refrigerator considerably lowers the temperature of the coffee.

19. Messages

DISPLAY	Cause	Action
FILL WATER	Water tank is empty Water level indicator in tank is jammed Tank is calcified, water level indicator is stuck	Top up with water Empty tank, rinse out, fill up and replace Remove tank, decalcify, rinse well, fill up with water and replace
FILL BEANS	Bean container is empty Message still displayed, although beans filled A foreign object is stuck in the grinder	Top up with beans Draw off cup of coffee. FILL BEANS message only disappears after coffee is drawn off Remove foreign object as described in chapter 14.5 “Removing foreign objects”
EMPTY GROUNDS	Coffee grounds container is full Message still displayed, although grounds container emptied. The message appears after only a few cups have been drawn off	Remove drip tray, empty grounds container, replace tray The tray was out of the machine for less than 8 sec for emptying. Take tray out again for approx. 10 sec and replace Leave the machine switched on while the grounds container is being emptied. The counter is only reset to zero if the machine is left switched on
TRAY MISSING	Tray has not been replaced correctly Grounds have fallen under tray and are preventing it from being correctly inserted	Insert tray correctly Remove tray, clean inside of machine, replace tray
EMPTY TRAY	The residual water container is full Message still displayed, although container emptied	Remove container carefully, empty, rinse out and replace Remove container, clean metal contacts (please refer to chapter 14.8)

DISPLAY	Cause	Action
CLEAN UNIT	You have drawn off coffee 220 times or run the rinsing program 180 times	Clean as described in chapter 15
	Message still displayed, although machine cleaned	Run cleaning program again; this time do not add cleaning tablet
UNIT CALCED COFFEE SECTOR WATER SECTOR	The appropriate sector needs decalcifying	Run decalcifying program as described in chapter 16
	Message still displayed, although machine decalcified	Run cleaning program again; this time using water only and without decalcifying agent
CLOSE TAP	Not ready to provide water or steam	Switch over to coffee sector, press water or steam key and then draw off the water or steam required
FAULT	Various causes	Ring the hotline

20. Problems

Problem	Cause	Action
Coffee only flows in dribs and drabs while drawing off	– Powder too fine	– Adjust grinder to a coarser grinding – Run one or two rinse programs If result is no better, clean the machine as per instruction
Coffee flow is stopped after pre-brewing	– Not enough coffee powder in the system	– Draw off one cup of coffee
Grinder is extremely noisy	– Foreign element in grinder	– Proceed as described in chapter 14.5
Not enough froth while frothing up milk	– Frothing nozzle blocked – Frothing nozzle in wrong position	– Clean frothing nozzle – Draw off steam

If the above mentioned problems and/or messages still persist, please contact your dealer or get in touch directly with JURA Elektroapparate AG.

21. Legal information

These operating instructions contain all the information necessary for the correct use, operation and maintenance of your espresso/ coffee machine.

Understanding and complying with the directions contained in these operating instructions are essential to ensure that the machine is utilised without risk and to ensure safety during operation and maintenance.



These operating instructions cannot cover all the possible ways in which this machine may be used. This machine has been designed for private use in households.

We would like to further point out that the contents of these operating instructions in no way constitute a part of, or alter, any previous or existing contract, agreement or legal relationship. All obligations on the part of JURA Elektroapparate AG result solely from the relevant sales agreement which also contains full details of the only warranty terms valid in respect of this machine. The contractual terms of this warranty are neither extended nor limited in any form by the information in these operating instructions.

These operating instructions contain information that is protected by copyright. The photocopying or translation into any other language of these instructions without prior written authorisation from JURA Elektroapparate AG is strictly prohibited.

22. Technical specifications

Impressa S85

Voltage:	230 V AC
Power consumption:	1350 W
Fuse:	10 A 
Safety measures exam:	
Energy consumption standby:	approx. 4.4
Energy consumption ready to make coffee:	approx. 31 Wh, Economy Mode on approx. 41 Wh, Economy Mode off
Pump pressure:	max. 15 bar
Water tank:	2.7 litres
Capacity, bean container:	280 gr
Capacity, grounds container:	max. 16 port.
Cable length:	approx. 1.1 m
Weight:	11.7 kg
Dimensions (BxHxD):	34.5 x 35 x 39 cm

The machine complies with the following EU directives:

73/23/EEG dated 19/02/1973 “Low Voltage Directive” including Modification Directive 93/336/EEG

89/336/EEG dated 03/05/1989 “EMC Directive” including Modification Directive 92/31/EEG