

# **NordicTrack** *9600 Upright Bike*

Model No. CEX32531

Model No. CEX35031

Serial No. \_\_\_\_\_

The serial number is found in the location shown below. Write the serial number in the space above.

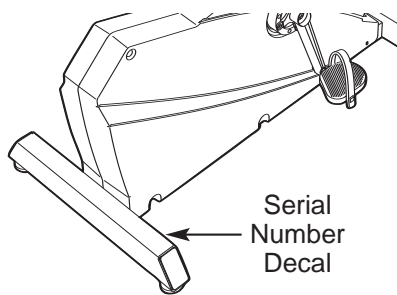

## QUESTIONS?

At FreeMotion Fitness, we're committed to providing complete customer satisfaction. For assistance, call Customer Care toll-free at:

**1-800-201-2109**

Mon.–Fri., 8 a.m.–5 p.m. MST

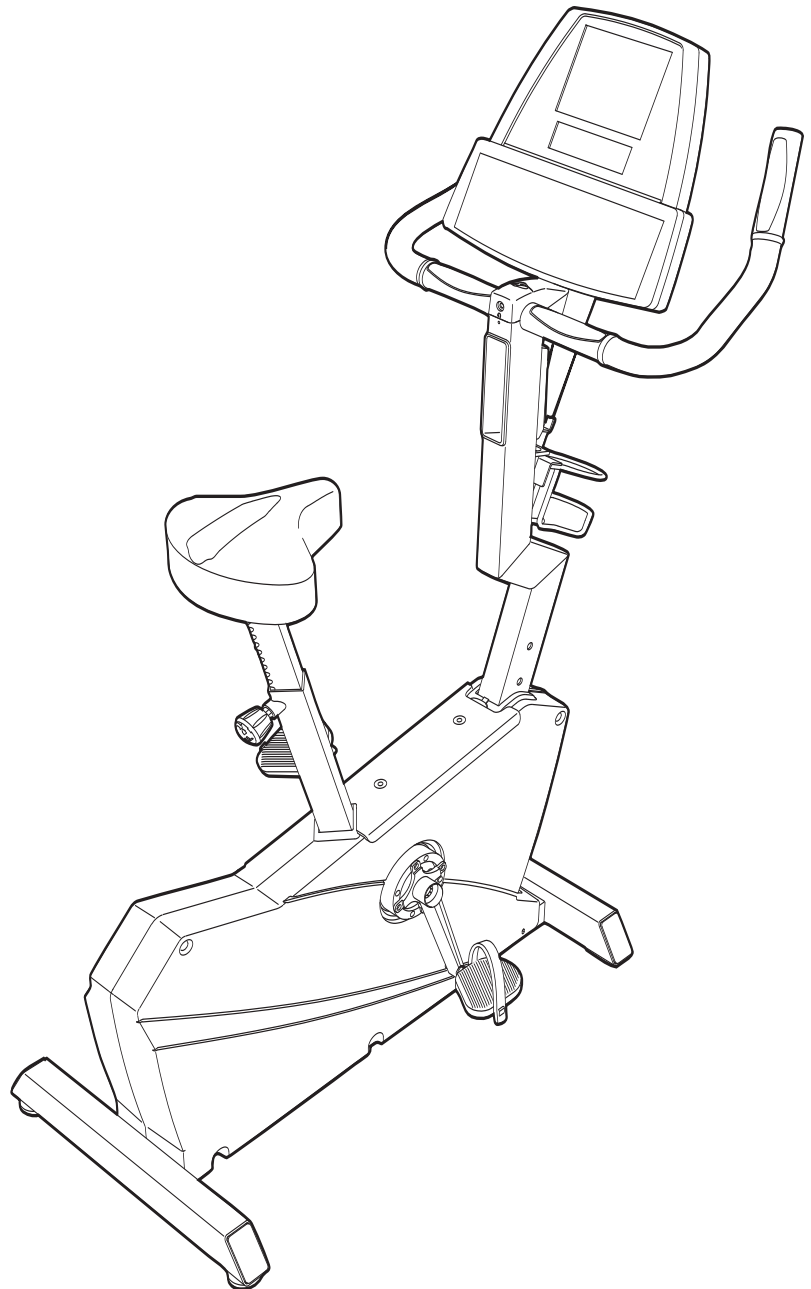

## CAUTION

Read all precautions and instructions in this manual before using this equipment. Keep this manual for future reference.

**USER'S MANUAL**





# NordicTrack

## 9600 Upright Bike

### TABLE OF CONTENTS

**SECTION 1**

- Important Precautions .....3
- Before You Begin .....4
- How to Assemble the Upright Bike .....5
- How to Set Up the Upright Bike .....6
- How to Upgrade the Console .....8

**SECTION 2**

- How to Use the Basic Console .....9
- How to Use the Workout TV Console .....23

**SECTION 3**

- Maintenance and Troubleshooting .....25

**SECTION 4**

- Exercise Guidelines .....27

**SECTION 5**

- Limited Warranty .....31
- Part List .....33
- Exploded Drawing .....34
- How to Order Replacement Parts .....36



# IMPORTANT PRECAUTIONS

**⚠ WARNING:** To reduce the risk of serious injury, read the following important precautions and information before operating the upright bike.

1. It is the responsibility of the owner to ensure that all users of the upright bike are adequately informed of all warnings and precautions.
2. Operate the upright bike only as described in this manual.
3. Do not operate the upright bike until it is properly assembled (see HOW TO ASSEMBLE THE UPRIGHT BIKE on page 5).
4. Keep the upright bike indoors, away from moisture and dust. Do not place the upright bike in a garage or covered patio or near water.
5. Place the upright bike on a level surface. To protect the floor or carpet from damage, place a mat beneath the upright bike.
6. Regularly inspect and tighten all parts of the upright bike.
7. Keep children under the age of 12 and pets away from the upright bike at all times.
8. The upright bike should not be used by persons weighing more than 350 pounds.
9. Always wear appropriate exercise clothes and athletic shoes when operating the upright bike. Do not wear loose clothes that could become caught on the upright bike.
10. Do not modify the power cord or use an adapter to connect the power cord to an improper receptical. Keep the power cord away from heated surfaces. Do not use an extension cord.
11. Keep your back straight when using the upright bike; do not arch your back.
12. If you feel pain or dizziness while exercising, stop immediately and cool down.
13. The pulse sensor is not a medical device. Various factors, including the user's movement, may affect the accuracy of heart rate readings. The pulse sensor is intended only as an exercise aid in determining heart rate trends in general.

**⚠ WARNING:** Before beginning this or any exercise program, consult your physician. This is especially important for persons over the age of 35 or persons with pre-existing health problems. Read all instructions before using. ICON assumes no responsibility for personal injury or property damage sustained by or through the use of this product.

**SAVE THESE INSTRUCTIONS**

# BEFORE YOU BEGIN

Congratulations for selecting the revolutionary NordicTrack® 9600 upright bike. The NordicTrack 9600 upright bike offers an impressive array of features to make your workouts more effective and enjoyable.

**For your benefit, read this manual carefully before using the NordicTrack 9600 upright bike.** If you have questions after reading this manual, please call Customer Care toll-free at 1-800-201-2109, Monday through Friday, 8 a.m. until 5 p.m. Mountain Time

(excluding holidays). To help us assist you, please note your product model number and serial number before calling. The model number of your upright bike is CEX32531 or CEX35031. The serial number can be found on a decal attached to the upright bike (see the front cover of this manual for the location of the decal).

Before reading further, please familiarize yourself with the parts that are labeled in the drawing below.

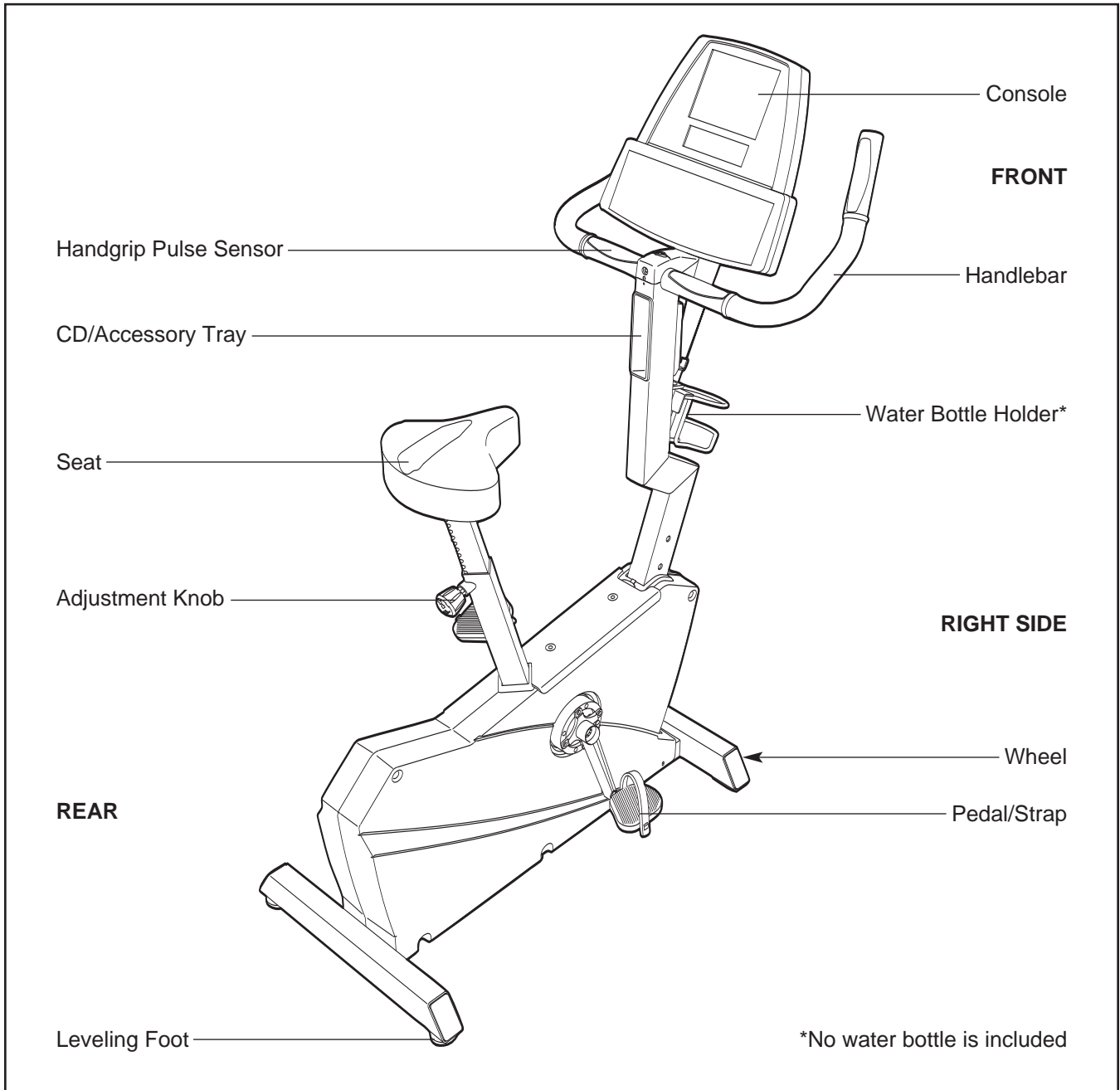

# HOW TO ASSEMBLE THE UPRIGHT BIKE

**Assembly requires two persons.** Set the upright bike in a cleared area and remove all packing materials. Do not dispose of the packing materials until assembly is completed. **Assembly can be completed using the included Allen wrench.**

Insert the console wires down into the Frame (1) and up into the Upright (3). Attach the Upright to the Frame with six 3/8" x 1 1/4" Button Screws (53). **Make sure that the wires are not pinched between the Upright and the Frame.**

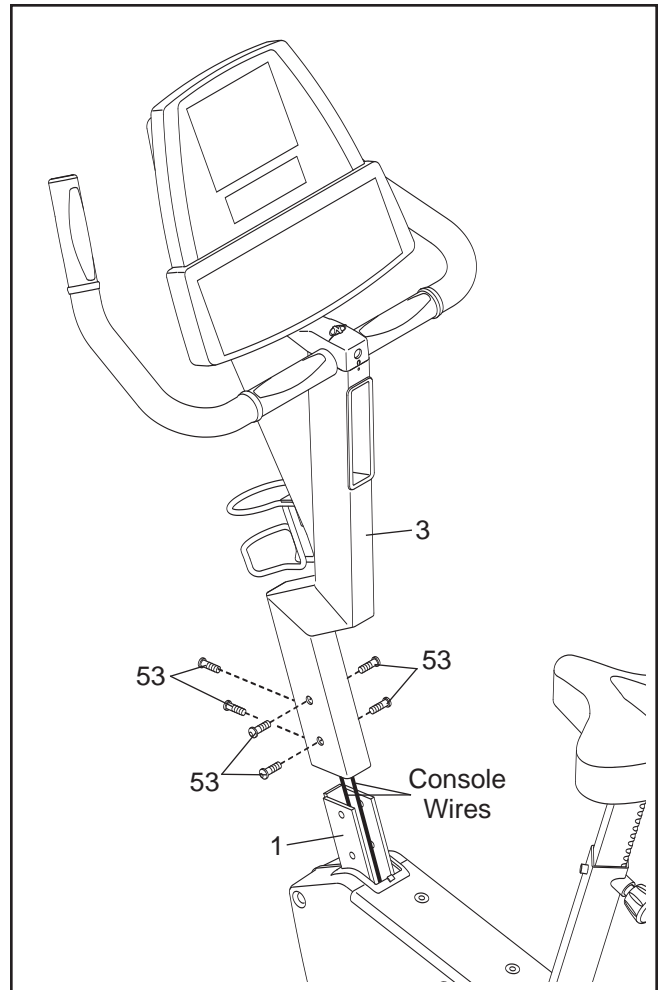

# HOW TO SET UP THE UPRIGHT BIKE

## HOW TO MOVE AND LEVEL THE UPRIGHT BIKE

**Before moving the upright bike, make sure that the power cord is unplugged.** Note: If a CATV cable is connected to the upright bike, it may be necessary to disconnect the cable if the upright bike will be moved far.

**Due to the size and weight of the upright bike, moving it requires two persons.** While one person lifts the indicated end, firmly hold the handlebar and tip the upright bike forward until it rolls on the front wheels. Carefully move the upright bike to the desired location and then lower it back to the level position. **CAUTION: To reduce the risk of injury, use extreme caution while moving the upright bike. Do not attempt to move the upright bike over uneven surfaces.**

If the upright bike rocks slightly during use, turn the leveling feet under the rear of the frame until the rocking motion is eliminated.

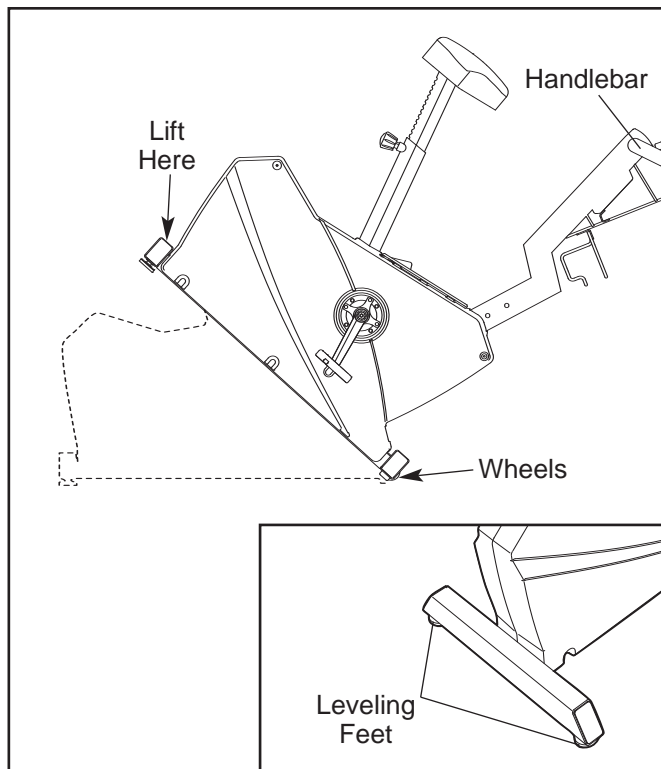

## HOW TO ADJUST THE SEAT

For effective exercise, the seat should be at the proper height. As you pedal, there should be a slight bend in your knees when the pedals are in the lowest position. To adjust the height of the seat, first turn the indicated knob counterclockwise about one turn to loosen it (if the knob is not loosened enough, it may scratch the seat post). Next, pull the knob, slide the seat post to the desired height, and then release the knob. **Move the seat post up and down slightly until the pin on the knob snaps into one of the holes in the seat post.** Then, turn the knob clockwise until it is tight.

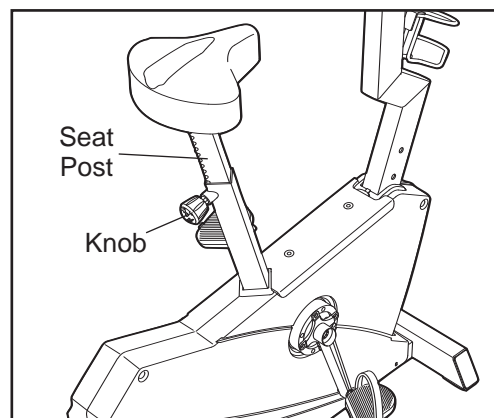

## HOW TO CONNECT THE POWER CORD

If the upright bike has a Basic console, it can be used with or without the included power cord. If the upright bike has a Workout TV console, the power cord must be used for the TV to be operated.

To use the power cord, first plug one end of the power cord into the jack on the front of the upright bike. Plug the other end of the power cord into an appropriate outlet that is properly installed in accordance with all local codes and ordinances.

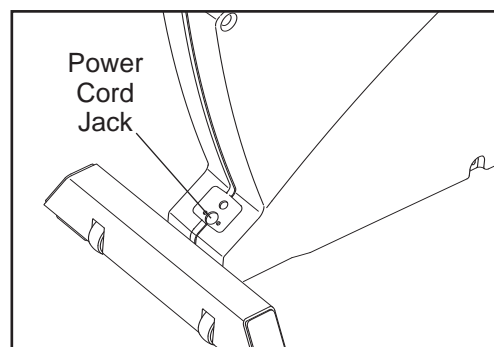



## HOW TO CONNECT A CATV CABLE

If your upright bike has a Workout TV console, a CATV cable must be connected to the upright bike for cable TV stations to be viewed.

Locate the cable jack on the front of the upright bike. Connect the CATV cable to the cable jack.

A satellite receiver, VCR, or DVD player can also be connected to the upright bike. Connect a CATV cable from the coaxial output on your equipment (usually labeled TV OUT or RF OUT) to the cable jack. Note: Audio/video equipment without coaxial outputs (some satellite receivers and DVD players) will require an RF modulator to operate with the upright bike. RF modulators and external CATV cables are not available from FreeMotion Fitness, but are available at electronics stores. See the owner's manual included with the equipment you wish to connect to see whether an RF modulator is needed.

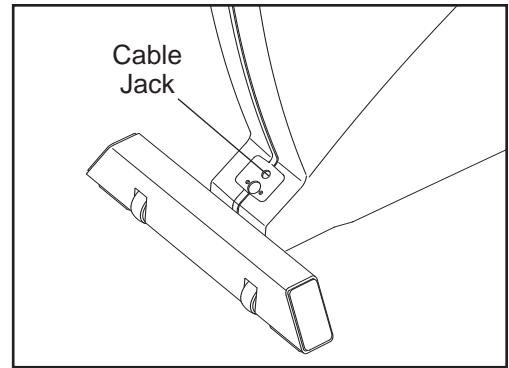

# HOW TO UPGRADE THE CONSOLE

Your upright bike has been pre-configured to operate with a Basic console and a Workout TV console (see the drawings below). To learn about the features of the Basic console, see page 9. For information about the state-of-the-art Workout TV console, see page 23.

To upgrade your console and expand the capabilities of your upright bike whenever you choose, simply contact your local FreeMotion Fitness Sales Representative or call FreeMotion Fitness toll-free at 1-877-363-8449.

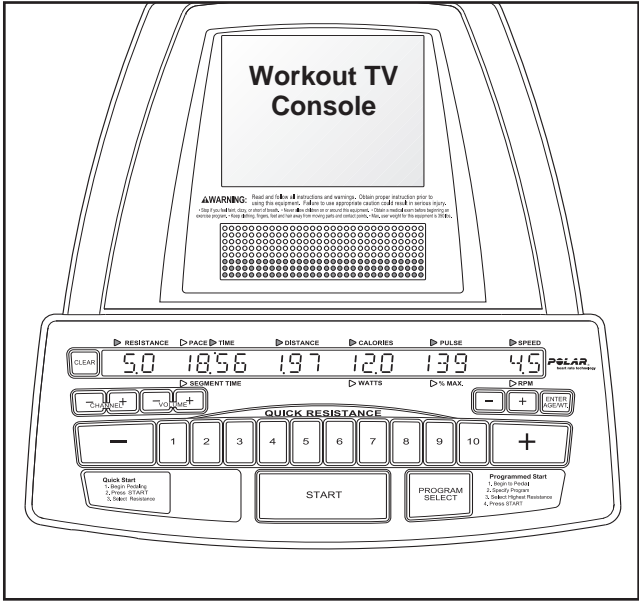
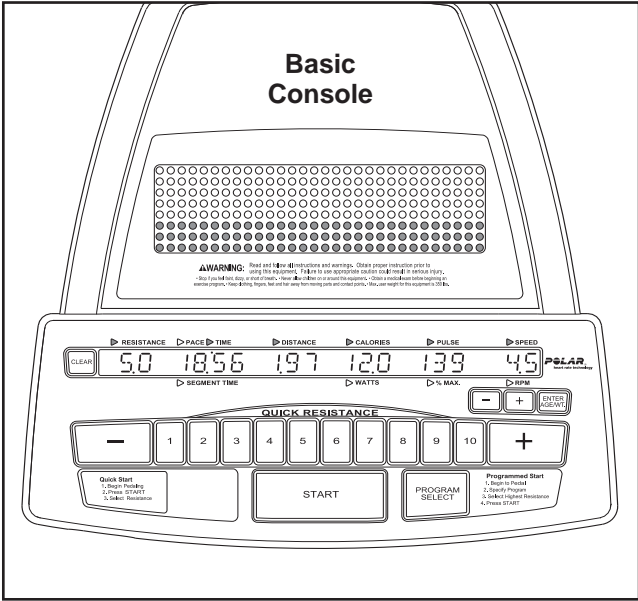

# HOW TO USE THE BASIC CONSOLE

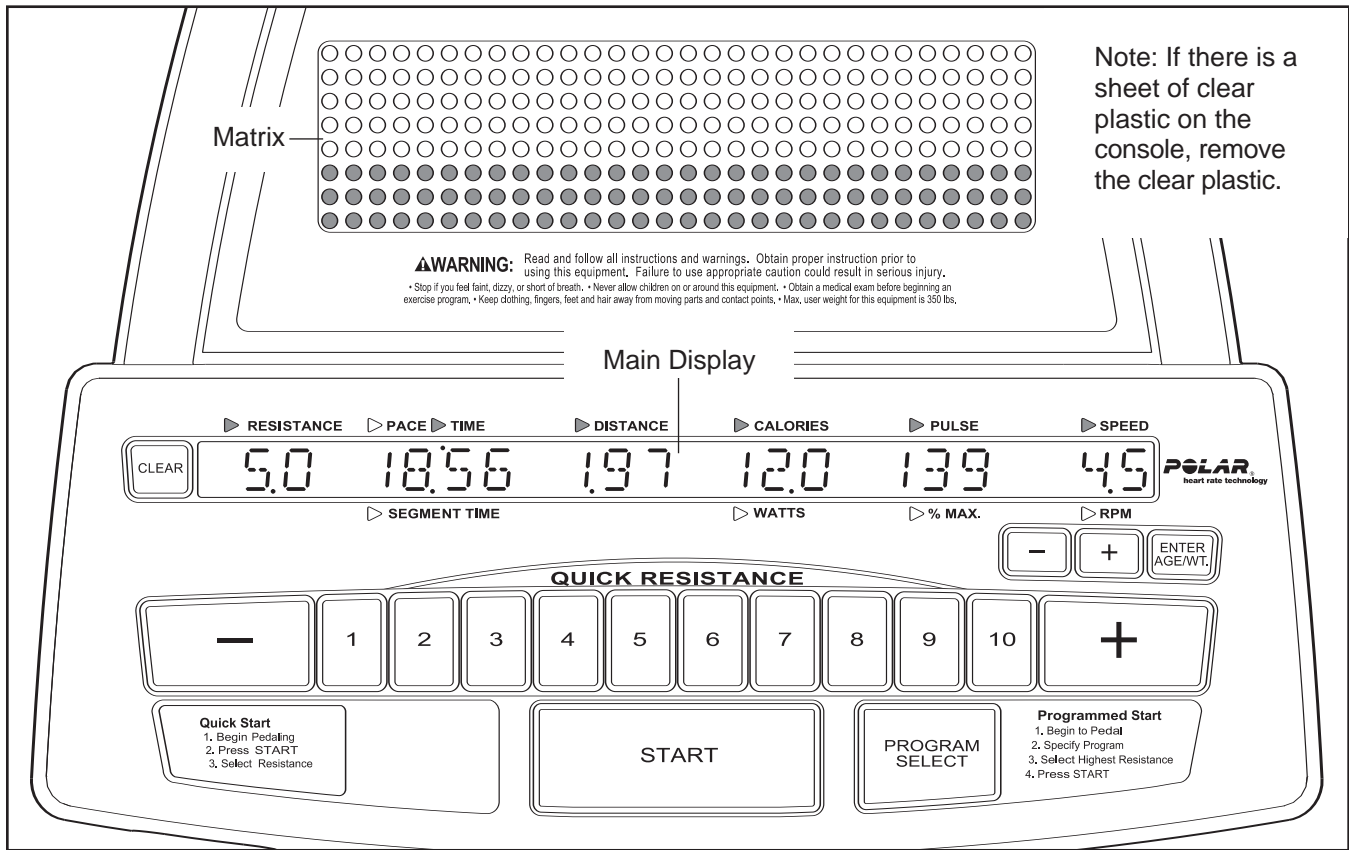

## FEATURES OF THE CONSOLE

The Basic console offers an impressive array of features to help you get the most from your exercise.

When the manual mode of the console is selected, the resistance of the pedals can be changed with a touch of a button. As you exercise, the console will provide continuous exercise feedback. You can even measure your heart rate using the built-in pulse sensor.

A variety of preset workout programs is also offered. Each program automatically controls the resistance of the pedals as it guides you through an effective workout.

In addition, the console offers three pulse programs that adjust the resistance of the pedals to keep your heart rate near target levels during your workouts, and a unique fitness test program that measures your VO<sub>2</sub> max level. Note: The pulse programs and the fitness test program require the use of a Polar®-compatible chest pulse sensor (not included).

**To use the QUICK START mode of the console,** follow the steps beginning on page 10. **To use a preset program,** see pages 12 to 16. **To use a pulse program,** see page 17. **To use the fitness test program,** see page 19. **To use the maintenance mode,** see page 20.

## HOW TO USE THE QUICK START MODE

### 1 Plug in the power cord or begin pedaling to activate the console.

If the upright bike has a Basic console, it can be used with or without the included power cord. **To use the power cord**, see HOW TO CONNECT THE POWER CORD on page 6. **To use the upright bike without the power cord**, begin pedaling at a cadence of about 20 revolutions per minute (RPM) or faster. After a moment, the console displays will light and a series of tones will sound. While you pedal, power will be supplied by a generator; remember to continue pedaling while using the upright bike.

If the upright bike has a Workout TV console, the power cord must be used for the TV to be operated.

### 2 Select the QUICK START mode.

When the power is turned on, the QUICK START mode will be selected. If you have already selected a program, select the QUICK START mode again by repeatedly pressing the PROGRAM SELECT button until the words “QUICK START” appear in the main display.

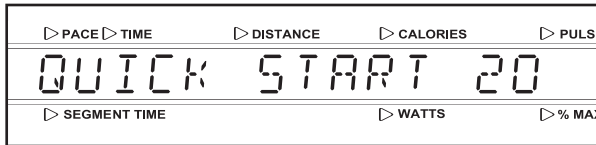

A few seconds after the QUICK START mode is selected, the words “QUICK START” will begin to scroll across the main display.

### 3 Press the START button and begin pedaling.

When the button is pressed, the console will begin displaying exercise data.

### 4 Change the resistance of the pedals as desired.

As you pedal, change the resistance of the pedals by pressing the RESISTANCE + and – buttons. To change the resistance quickly, press the QUICK RESISTANCE buttons. There are twenty resistance levels, from level 0.5 to level 10.



### 5 Follow your progress with the matrix and the main display.

**The matrix**—When the QUICK START mode is selected, the matrix will show a graph of the resistance levels that you select. The flashing column shows the current resistance level. Every thirty seconds, all columns will move one position to the left. As you increase or decrease the resistance, additional indicators will light or darken in the flashing column (and in all columns to the right).

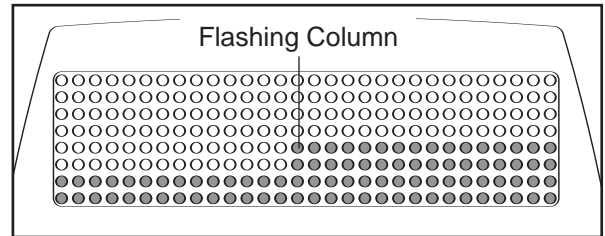

Note: The matrix shows *relative* resistance levels. As you increase or decrease the resistance, the lit indicators in all columns may shift upward or downward so that the highest indicators are always shown in the matrix.

**The main display**—The main display will show the following information:

**Resistance**—The left end of the main display will show the resistance level of the pedals.

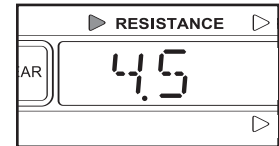

**Pace/Time**—When the Quick Start mode is selected, this section of the main display will show your pedaling pace (in *minutes per mile*) and the elapsed time. The display will change from one number to the other every few seconds. Note: Any time that the resistance level changes, the display will show your pedaling pace.

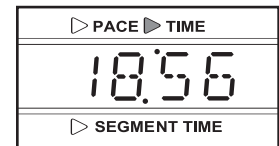

Note: When a preset program or a pulse program is selected, the display will show your pedaling pace, the time remaining in the program, and the time remaining in the current segment of the program. During the fitness test program, the display will show the elapsed time.

**Distance**—This section of the main display will show the distance that you have pedaled, in miles or kilometers.

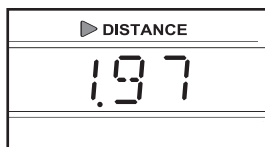

**Calories/Watts**—This section of the main display will show the approximate number of Calories you have burned and your power output in watts. The display will change from one number to the other every few seconds.



Note: If you enter your weight into the console, the console will measure your Calorie expenditure more accurately. To enter your weight, press the ENTER AGE/WT. button. The words "ENTER WEIGHT" and the current weight setting will scroll across the main display. To enter your weight, press the + and – buttons beside the ENTER AGE/WT. button. When your weight is shown, press the ENTER AGE/WT. button again.



**Pulse/% Max**—When you use the handgrip pulse sensor or a Polar®-compatible chest pulse sensor (not included), this section of the main display will show your heart rate (see step 6). When a pulse program is selected, the display will show your heart rate and the corresponding *percentage* of your *estimated maximum heart rate* (see step 5 on page 17 for an explanation of your estimated maximum heart rate). The display will change from one number to the other every few seconds.

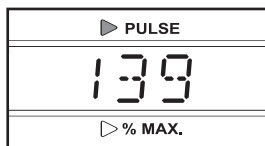

**Speed/RPM**—The right end of the main display will show your pedaling speed, in miles per hour or kilometers per hour, and your pedaling cadence, in revolutions per minute. The display will change from one number to the other every few seconds.

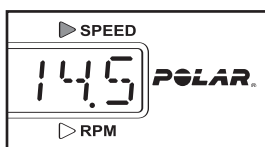

To reset the main display at any time, press the CLEAR button.

## 6 Measure your pulse if desired.

If there are thin sheets of plastic on the metal contacts on the handgrip pulse sensor, peel off the plastic. To measure your pulse, hold the contacts; your thumbs must be resting on the inner contacts, and your fingers must be touching the outer contacts. **Avoid moving your hands.**

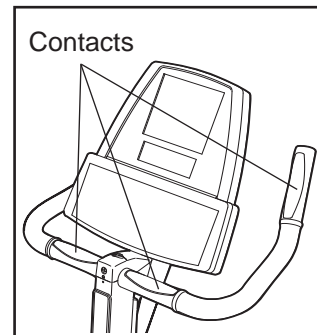

When your pulse is detected, the PULSE indicator above the main display will light, and then your heart rate will be shown. **For the most accurate pulse reading, hold the contacts for at least 15 seconds without moving.**

If your heart rate is not shown, make sure that your hands are positioned as described. Be careful not to move your hands excessively or to squeeze the contacts too tightly. For optimal performance, clean the contacts using a soft cloth; never use alcohol, abrasives, or chemicals.

Note: Keep cell phones and cordless phones away from the console when in use; these types of phones can affect pulse readings.

## 7 When you are finished using the upright bike, the console will automatically enter an idle mode or turn off.

If the power cord is being used, the words "PUSH ANY BUTTON TO START A NEW WORKOUT" will begin to scroll across the main display if the pedals are not moved for a few minutes. Unplug the power cord when the upright bike is not in use.

If the power cord is not being used, the console will automatically turn off if the pedals are not moved for several seconds.

## HOW TO USE THE TIMED WORKOUT PROGRAM

The TIMED WORKOUT program will count down the time remaining in your workout as you control the resistance of the pedals.

### 1 Plug in the power cord or begin pedaling to activate the console.

See step 1 on page 10.

### 2 Select the TIMED WORKOUT program.

To select the TIMED WORKOUT program, repeatedly press the PROGRAM SELECT button until the words "TIMED WORKOUT" appear in the main display.

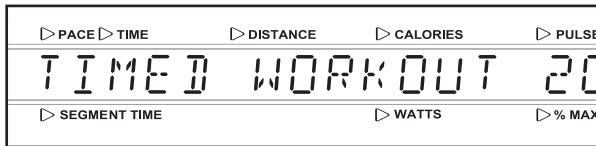

A few seconds after the program is selected, the name of the program and the total program time will begin to scroll across the main display. Note: The program can be set to last for 20, 30, 40, 50, or 60 minutes. See step 8 on page 20.

### 3 Press the START button and begin pedaling to start the program.

When the button is pressed, the console will begin displaying exercise data.

The TIMED WORKOUT program is divided into 30-second segments. During the program, the matrix will show your progress and the resistance levels that you select. The flashing column represents the current segment of the program. The number of lit indicators in the flashing column shows the resistance level for the current segment. At

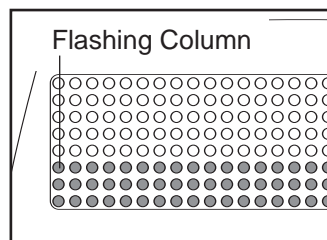

the end of each segment, a series of tones will sound, the time will flash in the main display, and the flashing column of the matrix will move one position to the right.

During the program, change the resistance of the pedals as desired by pressing the RESISTANCE + and – buttons or the QUICK RESISTANCE buttons. As you increase or decrease the resistance, additional indicators will light or darken in the flashing column (and in all columns to the right). Note: The matrix shows *relative* resistance levels. As you increase or decrease the resistance, the lit indicators in the columns may shift upward or downward so that the highest indicators are always shown in the matrix.

After you have completed the first three minutes of the program, the flashing column will no longer move to the right at the end of each segment. Instead, all columns of indicators will move one position to the left at the end of each segment.

When only 12 minutes remain in the program, the flashing column will again move one position to the right at the end of each segment, until the program is completed.

### 4 Follow your progress with the main display.

See step 5 on page 10.

### 5 Measure your pulse if desired.

See step 6 on page 11.

### 6 When you are finished using the upright bike, the console will automatically enter an idle mode or turn off.

See step 7 on page 11.

## HOW TO USE THE RANDOM HILLS PROGRAM

The RANDOM HILLS program will automatically change the resistance of the pedals during your workout. Each time the program is selected, the resistance settings of the program will be different.

### 1 Plug in the power cord or begin pedaling to activate the console.

See step 1 on page 10.

### 2 Select the RANDOM HILLS program.

To select the RANDOM HILLS program, repeatedly press the PROGRAM SELECT button until the words "RANDOM HILLS" appear in the main display.

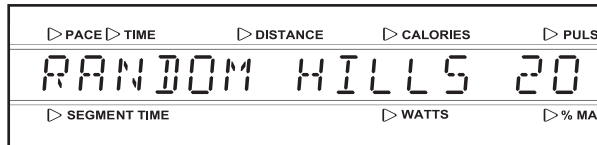

A few seconds after the program is selected, the name of the program and the total program time will begin to scroll across the main display. Note: To select a different RANDOM HILLS program, simply press the CLEAR button. The program can be set to last for 20, 30, 40, 50, or 60 minutes. See step 8 on page 20.

### 3 Press the START button and begin pedaling to start the program.

When the button is pressed, the console will begin displaying exercise data.

The program is divided into 30-second segments. One resistance level is programmed for each segment. (The same resistance level may be programmed for two or more consecutive segments.)

During the program, the matrix will show your progress and the resistance settings of the program. The flashing column represents

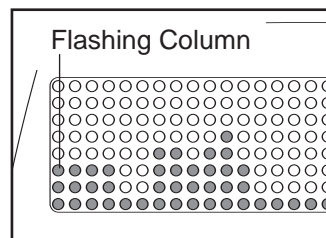

the current segment of the program. The number of lit indicators in the flashing column shows the resistance setting for the current segment. At the end of each segment, a series of tones will sound, the time will flash in the main display, and the flashing column of the matrix will move one position to the right. The resistance of the pedals will then automatically change if a different resistance level is programmed for the next segment. Note: The matrix shows *relative* resistance levels. The lit indicators in the columns may shift upward or downward so that the highest indicators are always shown in the matrix.

During the program, you can change the resistance of the pedals if desired by pressing the RESISTANCE + and – buttons or the QUICK RESISTANCE buttons. However, when the current segment ends, the resistance will automatically change if a different resistance level is programmed for the next segment. Note: The program begins with a two-minute warm-up period and ends with a two-minute cool-down period. During these periods, the resistance level cannot be changed.

After you have completed the first three minutes of the program, the flashing column will no longer move to the right at the end of each segment. Instead, all columns of indicators will move one position to the left at the end of each segment.

When only 12 minutes remain in the program, the flashing column will again move one position to the right at the end of each segment, until the program is completed.

### 4 Follow your progress with the main display.

See step 5 on page 10.

### 5 Measure your pulse if desired.

See step 6 on page 11.

### 6 When you are finished using the upright bike, the console will automatically enter an idle mode or turn off.

See step 7 on page 11.

## HOW TO USE THE WATTS WORKOUT PROGRAM

The WATTS WORKOUT program will automatically change the resistance of the pedals to keep your power output near a target level during your workout.

### 1 Plug in the power cord or begin pedaling to activate the console.

See step 1 on page 10.

### 2 Select the WATTS WORKOUT program.

To select the WATTS WORKOUT program, repeatedly press the PROGRAM SELECT button until the words “WATTS WORKOUT” appear in the main display.



A few seconds after the program is selected, the name of the program and the total program time will begin to scroll across the main display. Note: The program can be set to last for 20, 30, 40, 50, or 60 minutes. See step 8 on page 20.

### 3 Press the START button and enter a target watts setting for the program.

When the button is pressed, the words “ENTER TARGET WATTS” and the current target watts setting will scroll across the main display. If you wish to change the target watts setting for the program, press the + and – buttons beside the ENTER AGE/WT. button. The target watts setting can be changed in increments of 10 watts.

### 4 Press the START button and begin pedaling to start the program.

When the button is pressed, the console will begin displaying exercise data.

The program is divided into 30-second segments. The same target watts level is programmed for all

segments. During the program, the matrix will show your progress. The flashing column represents the current segment of the program. At the end of each

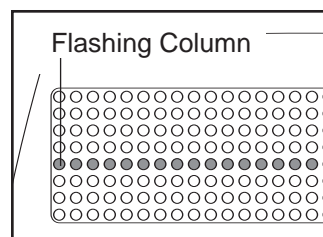

segment, a series of tones will sound, the time will flash in the main display, and the flashing column of the matrix will move one position to the right.

During the program, the console will compare your power output to the target watts setting. If your power output is too far above or below the target watts setting, the resistance of the pedals will automatically change to bring your power output closer to the target watts setting. Note: Pressing the RESISTANCE + and – buttons during the program will change the target watts setting for the program (see step 3).

After you have completed the first three minutes of the program, the flashing column will no longer move to the right at the end of each segment. Instead, all columns of indicators will move one position to the left at the end of each segment.

When only 12 minutes remain in the program, the flashing column will again move one position to the right at the end of each segment, until the program is completed.

### 5 Follow your progress with the main display.

See step 5 on page 10.

### 6 Measure your pulse if desired.

See step 6 on page 11.

### 7 When you are finished using the upright bike, the console will automatically enter an idle mode or turn off.

See step 7 on page 11.



## HOW TO USE THE CARDIO WORKOUT PROGRAM

The CARDIO WORKOUT program will automatically change the resistance of the pedals as it guides you through an effective cardiovascular workout.

### 1 Plug in the power cord or begin pedaling to activate the console.

See step 1 on page 10.

### 2 Select the CARDIO WORKOUT program.

To select the CARDIO WORKOUT program, repeatedly press the PROGRAM SELECT button until the words “CARDIO WORKOUT” appear in the main display.



A few seconds after the program is selected, the name of the program and the total program time will begin to scroll across the main display. Note: The program can be set to last for 20, 30, 40, 50, or 60 minutes. See step 8 on page 20.

### 3 Press the START button and enter a maximum resistance setting for the program.

When the button is pressed, the words “ENTER WORKOUT LEVEL” and the maximum resistance setting for the program will scroll across the main display. If you wish to change the maximum resistance setting, press the + and – buttons beside the ENTER AGE/WT. button. The maximum resistance setting can be from level 2 to level 10. Note: Increasing or decreasing the maximum resistance setting will increase or decrease the intensity level of the program.

### 4 Press the START button and begin pedaling to start the program.

When the button is pressed, the console will begin displaying exercise data.

The program is divided into 30-second segments. One resistance level is programmed for each segment.

During the program, the matrix will show your progress and the resistance settings of the program.

The flashing column represents the current segment of the program. The number of lit indicators in the flashing column shows the resistance setting for the current segment. At the end of each segment, a series of tones will sound, the time will flash in the main display, and the flashing column of the matrix will move one position to the right. The resistance of the pedals will then automatically change if a different resistance level is programmed for the next segment. Note: The matrix shows *relative* resistance levels. As you increase or decrease the resistance, the lit indicators in the columns may shift upward or downward so that the highest indicators are always shown in the matrix.

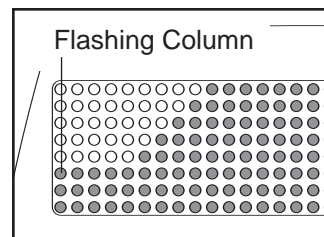

After you have completed the first three minutes of the program, the flashing column will no longer move to the right at the end of each segment. Instead, all columns of indicators will move one position to the left at the end of each segment.

When only 12 minutes remain in the program, the flashing column will again move one position to the right at the end of each segment, until the program is completed.

Note: Pressing the RESISTANCE + and – buttons or the QUICK RESISTANCE buttons during the program will change the maximum resistance setting of the program (see step 3).

### 5 Follow your progress with the main display.

See step 5 on page 10.

### 6 Measure your pulse if desired.

See step 6 on page 11.

### 7 When you are finished using the upright bike, the console will automatically enter an idle mode or turn off.

See step 7 on page 11.

## HOW TO USE THE HILLS INTERVAL PROGRAM

The HILLS INTERVAL program will automatically change the resistance of the pedals to simulate a series of hills as it guides you through an effective interval training workout.

### 1 Plug in the power cord or begin pedaling to activate the console.

See step 1 on page 10.

### 2 Select the HILLS INTERVAL program.

To select the HILLS INTERVAL program, repeatedly press the PROGRAM SELECT button until the words “HILLS INTERVAL” appear in the main display.

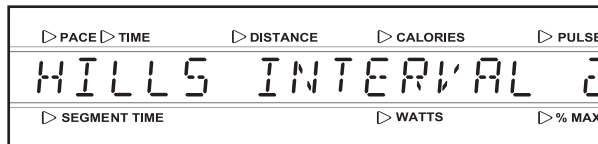

A few seconds after the program is selected, the name of the program and the total program time will begin to scroll across the main display. Note: The program can be set to last for 20, 30, 40, 50, or 60 minutes. See step 8 on page 20.

### 3 Press the START button and enter a maximum resistance setting for the program.

See step 3 on page 15.

### 4 Press the START button and enter the desired number of hills for the program.

When the button is pressed, the words “NUMBER OF HILLS” and the number of hills that the program will simulate will scroll across the main display. If you wish to change the number of hills, press the + and – buttons beside the ENTER AGE/WT. button. The program can simulate from 2 to 10 hills.

### 5 Press the START button and begin pedaling to start the program.

When the button is pressed, the console will begin displaying exercise data.

The program is divided into 30-second segments. One resistance level is programmed for each segment.

During the program, the matrix will show your progress and the resistance settings of the program.

The flashing column represents the current segment of the program. The number of lit indicators in the flashing column shows the resistance setting for the current segment. At the end of each segment, a series of tones will sound, the time will flash in the main display, and the flashing column of the matrix will move one position to the right. The resistance of the pedals will then automatically change if a different resistance level is programmed for the next segment. Note: The matrix shows *relative* resistance levels. As you increase or decrease the resistance, the lit indicators in the columns may shift upward or downward so that the highest indicators are always shown in the matrix.

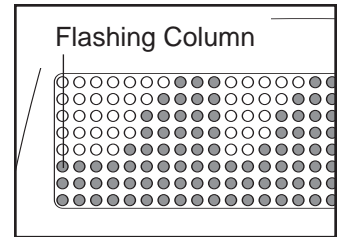

After you have completed the first three minutes of the program, the flashing column will no longer move to the right at the end of each segment. Instead, all columns of indicators will move one position to the left at the end of each segment.

When only 12 minutes remain in the program, the flashing column will again move one position to the right at the end of each segment, until the program is completed.

Note: Pressing the RESISTANCE + and – buttons or the QUICK RESISTANCE buttons during the program will change the maximum resistance setting for the program (see step 3).

### 6 Follow your progress with the main display.

See step 5 on page 10.

### 7 Measure your pulse if desired.

See step 6 on page 11.

### 8 When you are finished using the upright bike, the console will automatically enter an idle mode or turn off.

See step 7 on page 11.

## HOW TO USE THE PULSE PROGRAMS

The three pulse programs automatically control the resistance of the pedals to keep your heart rate near a target level while you exercise.

### 1 Put on a Polar®-compatible chest pulse sensor (not included).

You must wear a chest pulse sensor to use a pulse program. See the instructions included with your chest pulse sensor.

### 2 Plug in the power cord or begin pedaling to activate the console.

See step 1 on page 10.

### 3 Select one of the three pulse programs.

To select a pulse program, repeatedly press the PROGRAM SELECT button until the words “CARDIO PULSE,” “ENDURANCE PULSE,” or “MANUAL PULSE” appear in the main display. Note: The CARDIO PULSE program will keep your heart rate near 65% of your *estimated maximum heart rate* (see step 5 at the right for an explanation of estimated maximum heart rate). The ENDURANCE PULSE program will keep your heart rate near 80% of your estimated maximum heart rate. The MANUAL PULSE program will keep your heart rate near a percentage that you select.



A few seconds after the program is selected, the name of the program and the total program time will begin to scroll across the main display.

Note: During pulse programs, the matrix will show a moving graphic that represents your heart rate. Each time a heart-beat is detected, an additional peak will appear in the graphic.

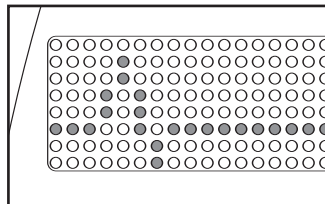

### 4 Press the START button and enter your age.

When the button is pressed, the words “ENTER AGE” and the current age setting will appear in the main display. To enter your age, press the + and – buttons beside the ENTER AGE/WT. button.

If you have selected the **CARDIO PULSE** program or the **ENDURANCE PULSE** program, go to step 6. If you have selected the **MANUAL PULSE** program, go to step 5.

### 5 Press the START button and enter a target heart rate setting.

When the button is pressed, the words “ENTER PERCENT” and the current target heart rate setting for the program will appear in the main display. The target heart rate setting represents a *percentage* of your *estimated maximum heart rate*. Note: Your estimated maximum heart rate is determined by subtracting your age from 220. For example, if you are 30 years old, your estimated maximum heart rate is 190 beats per minute ( $220 - 30 = 190$ ). Therefore, if you are 30 years old, a target heart rate setting of 65% is equal to 123 beats per minute (65% of 190 is 123).

If desired, you can change the target heart rate setting by pressing the + and – buttons beside the ENTER AGE/WT. button. The target heart rate setting can be from 50% to 85% of your estimated maximum heart rate.

### 6 Press the START button and begin pedaling to start the program.

When the button is pressed, the console will begin displaying exercise data.

The program is divided into 30-second segments. One target heart rate setting is programmed for each segment. (If the MANUAL PULSE program is selected, the same target heart rate setting is programmed for all segments.)

At the end of each segment, a series of tones will sound, and then the resistance of the pedals will automatically increase or decrease, if necessary, to bring your heart rate closer to the target heart rate setting for the next segment. The program will continue in this way until the main display shows that no time remains in the program.

During the program, you can change the resistance of the pedals, if desired, by pressing the RESISTANCE + and – buttons or the QUICK RESISTANCE buttons. However, when the current segment ends, the resistance will automatically increase or decrease, if needed, to bring your heart rate closer to the target heart rate setting for the next segment. Note: Each pulse program begins with a two-minute warm-up period and ends with a two-minute cool-down period. During these periods, the resistance level cannot be changed.

If your pulse is not detected during the program, the letters “PLS” will flash in the main display, and

the resistance of the pedals may automatically decrease. If this occurs, see the instructions included with your chest pulse sensor.

**7 Follow your progress with the main display.**

See step 5 on page 10.

**8 When you are finished using the upright bike, the console will automatically enter an idle mode or turn off.**

See step 7 on page 11.

## HOW TO USE THE FITNESS TEST PROGRAM

The FITNESS TEST program measures your VO2 max level. For the best results, the program should be used at a time when your energy level is high; the program should not be used if you have already exercised during the day. Follow the steps below to use the program.

### 1 Put on a Polar®-compatible chest pulse sensor (not included).

You must wear a chest pulse sensor to use the FITNESS TEST program. See the instructions included with your chest pulse sensor.

### 2 Plug in the power cord or begin pedaling to activate the console.

See step 1 on page 10.

### 3 Select the FITNESS TEST program.

To select the FITNESS TEST program, press the PROGRAM SELECT button repeatedly until the words “FITNESS TEST” appear in the main display.



A few seconds after the program is selected, the name of the program will begin to scroll across the main display.

Note: During the FITNESS TEST program, the matrix will show a moving graphic that represents your heart rate. Each time a heart-beat is detected, an additional peak will appear in the graphic.

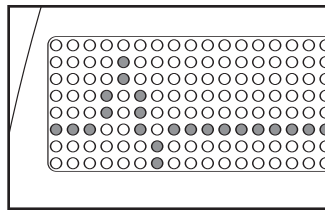

### 4 Press the START button and enter your age.

When the button is pressed, the words “ENTER AGE” and the current age setting will appear in the main display. To enter your age, press the + and – buttons beside the ENTER AGE/WT. button.

### 5 Press the START button and enter your weight.

When the button is pressed, the words “ENTER WEIGHT” and the current weight setting will scroll across the main display. To enter your weight, press the + and – buttons beside the ENTER AGE/WT. button.

### 6 Press the START button and begin pedaling to start the program.

When the button is pressed, the console will begin displaying exercise data.

The FITNESS TEST program is divided into three-minute segments. During the program, the console will automatically control the resistance of the pedals and prompt you to pedal at a cadence of 50 revolutions per minute (RPM). If you pedal more than 5 RPM faster or slower than 50 RPM, a tone will sound and the words, “PLEASE PEDAL AT 50 RPM” will scroll across the main display.

When the first three-minute segment of the program is completed, a tone will sound and the second segment will begin. The program will continue until the console has measured your VO2 max level. Your VO2 max level will then begin to scroll across the main display.

Note: The RESISTANCE + and – buttons and the QUICK RESISTANCE buttons will not function while the FITNESS TEST program is selected. If your pulse is not detected during the program, the letters “PLS” will flash in the main display. If your pulse is not detected at the end of any segment, the program will end and the main display will show a VO2 max level of 000.

### 7 Follow your progress with the main display.

See step 5 on page 10.

### 8 When you are finished using the upright bike, the console will automatically enter an idle mode or turn off.

See step 7 on page 11.

## HOW TO USE THE MAINTENANCE MODE

The console features a maintenance mode that allows you to access information and to view and change default settings. Follow the steps below to use the maintenance mode.

- 1 Plug in the power cord or begin pedaling to activate the console.**

See step 1 on page 10.

- 2 Hold down the CLEAR button and the ENTER AGE/WT. button simultaneously for a few seconds to select the maintenance mode.**

When the maintenance mode is selected, the words MAINTENANCE MODE will appear in the main display.



- 3 Press the ENTER AGE/WT. button and select a language for the main display.**

The main display can display text in English, UK English, Spanish, Italian, German, or French. To change the language, press the + and – buttons beside the ENTER AGE/WT. button.

- 4 Press the ENTER AGE/WT. button again and select the desired system of measurement.**

The console can display data using the standard system (miles and pounds) or the metric system (kilometers and kilograms). To change the system of measurement, press the + and – buttons beside the ENTER AGE/WT. button.

- 5 Press the ENTER AGE/WT. button again and view the service time.**

The console will show the total number of hours that the upright bike has been used since the service time was reset. To reset the service time, press the CLEAR button.

- 6 Press the ENTER AGE/WT. button again and view the service distance.**

The console will show the total distance pedaled on the upright bike since the service distance was reset. To reset the service distance, press the CLEAR button.

- 7 Press the ENTER AGE/WT. button again and set the delay time for the idle mode.**

If the power cord is used with the upright bike, and if the pedals are stationary for several minutes, the console will enter an idle mode and the words “PUSH ANY BUTTON TO START A NEW WORKOUT” will begin to scroll across the main display. To set the number of minutes before the console will enter the idle mode, press the + and – buttons beside the ENTER AGE/WT. button. The delay time can be from 1 to 15 minutes.

- 8 Press the ENTER AGE/WT. button again and set the program time for the programs.**

The programs (except for the FITNESS TEST program) can be set to last for 20, 30, 40, 50, or 60 minutes. To change the length of time, press the + and – buttons beside the ENTER AGE/WT. button.

**If the upright bike has a Basic console, go to step 12. If the upright bike has a Workout TV console, go to step 9.**

- 9 Press the ENTER AGE/WT. button again and choose a connection setting for the TV.**

To prevent the TV from being used, press the + and – buttons beside the ENTER AGE/WT. button until the words “TV DISABLED” appear in the main display.

To make the TV available for use, press the + and – buttons beside the ENTER AGE/WT. button to select one of the following connection settings: TV NTSC AIR, TV NTSC CABLE, TV NTSC HRC CABLE, TV NTSC IRC CABLE, TV PAL I AIR, TV PAL I CABLE, TV PAL B/G AIR, TV PAL B/G CABLE, TV NTSC J AIR, or TV NTSC J CABLE.

**Note: For help selecting the correct setting, see page 22.**

**If you have disabled the TV, go to step 12. If you have enabled the TV, go to step 10.**

**10** Press the ENTER AGE/WT. button again and program TV channels.

The console has the capability to find and store in memory all of the valid TV channels in your area. While the words "PRESS CHANNEL UP TO SCAN" appear in the main display, press the CHANNEL + button to start the channel scanning process.

The console will begin scanning all TV channels. If no broadcast signal is detected on a channel, the channel will be skipped; if a signal is detected, a tone will sound and the channel will be stored in memory. This process will continue until the highest channel is reached. The lowest channel stored in memory will then appear in the main display.

**11** Press the ENTER AGE/WT. button again and delete or add TV channels.

After all valid TV channels have been stored in the console's memory, you can delete unwanted

channels or add channels. To delete or add a channel, first press the CHANNEL + and – buttons until the channel appears in the main display.

To delete a channel, press the + or – button beside the ENTER AGE/WT. button so that the word "SAVED" does not appear next to the channel. To add a channel, press the + or – button so that the word "SAVED" appears next to the channel. Then, select the next channel that you want to delete or add. Repeat this process until you have deleted all unwanted channels and added all desired channels.

**12** Hold down the ENTER AGE/WT. button and the CLEAR button simultaneously for a few seconds to exit the maintenance mode.

To exit the maintenance mode at any time, hold down the ENTER AGE/WT. button and the CLEAR button simultaneously for a few seconds.

## TV CONNECTION SETTINGS

See the chart below to find the correct TV connection setting for your country. See step 9 on page 20 to select a setting. Note: Your upright bike has an NTSC-compatible console; the console is not compatible with PAL settings.

		SYSTEM					
		NTSC	NTSC	NTSC J	PAL B/G	PAL B/G	PAL I
<b>COUNTRY</b>	Bahamas	Trinidad	Japan	Afghanistan	Malaysia	Angola	
	Barbados	Tobago		Albania	Malawi	Botswana	
	Bermuda	U.S.A.		Algeria	Mozambique	Hong Kong	
	Cambodia	Venezuela		Australia	Netherlands	S. Africa	
	Canada	Virgin Is.		Austria	N. Zealand	Zanzibar	
	Chile	Vietnam		Azores	Nigeria	U.K.	
	Colombia			Bahrain	Norway		
	Costa Rica			Bangladesh	Oman		
	Cuba			Brunei	Pakistan		
	Dominican			Cameroon	Palestine		
	Ecuador			Canary Is.	N. Guinea		
	El Salvador			Cape Verde	Portugal		
	Greenland			Cyprus	Qatar		
	Guam			Denmark	Sierra Leone		
	Guatamala			Fiji	Singapore		
	Haiti			Finland	Spain		
	Honduras			Germany	Sri Lanka		
	Jamaica			Ghana	Sudan		
	Korea (S.)			Iceland	Swaziland		
	Mexico			India	Sweden		
	Micronesia			Indonesia	Switzerland		
	Myanmar			Israel	Thailand		
	Nicaragua			Italy	Turkey		
	Panama			Jordan	Uganda		
Peru			Konya	Yemen			
Phillipines			Kuwait	U.A.E.			
Puerto Rico			Laos	Zambia			
Samoa			Leichtenstein	Zimbabwe			
Suriname			Madeira				
Taiwan			Majorca Is.				



# HOW TO USE THE WORKOUT TV CONSOLE

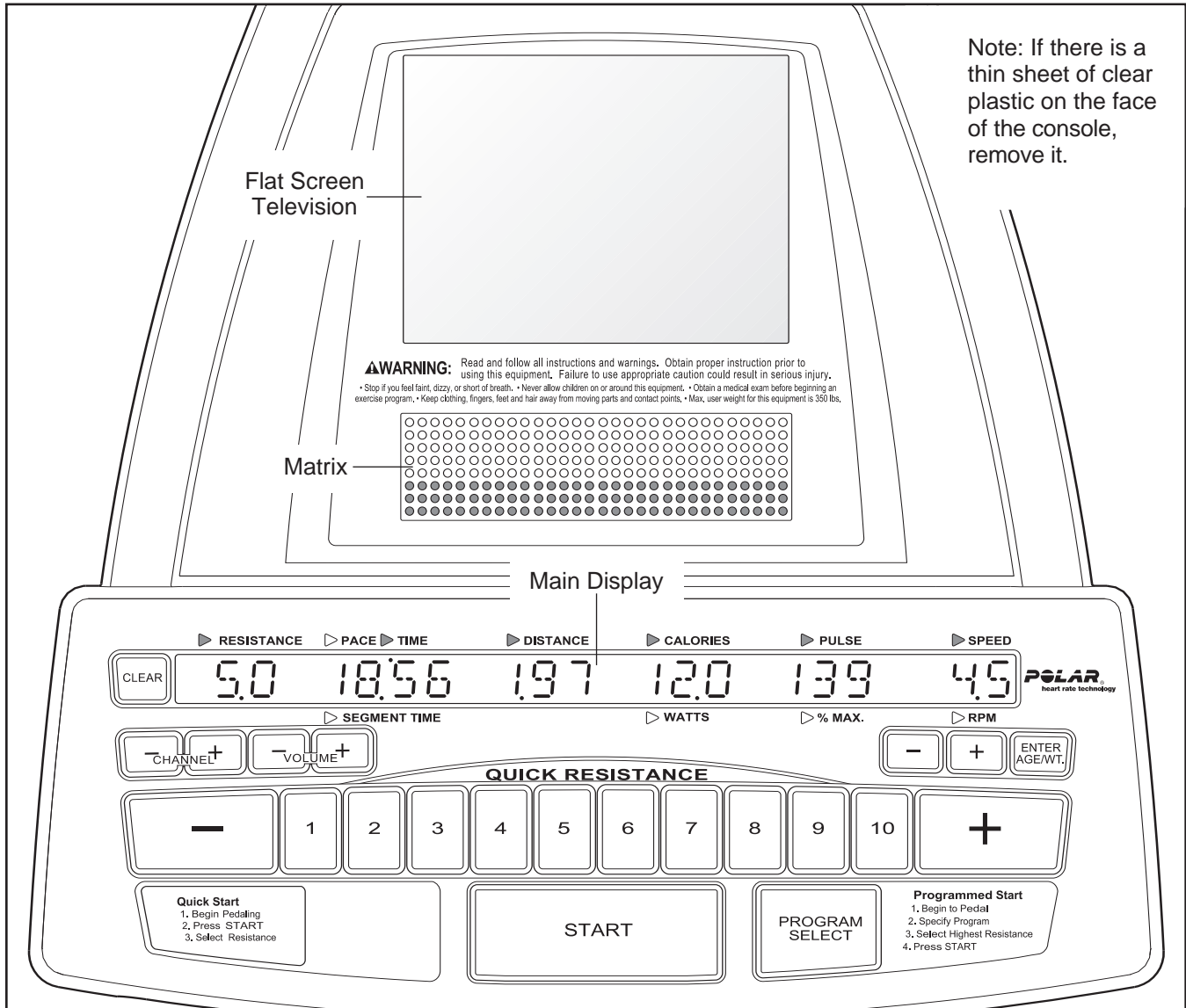

## FEATURES OF THE CONSOLE

The state-of-the-art Workout TV console offers an impressive array of features to make your workouts more effective and enjoyable.

When the manual mode of the console is selected, the resistance of the pedals can be changed with a touch of a button. As you exercise, the console will provide continuous exercise feedback. You can even measure your heart rate using the built-in pulse sensor.

A variety of preset workout programs is also offered. Each program automatically controls the resistance of the pedals as it guides you through an effective workout.

In addition, the console offers three pulse programs that adjust the resistance of the pedals to keep your heart rate near target levels during your workouts, and a unique fitness test program that measures your VO<sub>2</sub> max level. Note: The pulse programs and the fitness test program require the use of a Polar®-compatible chest pulse sensor (not included).

No matter which mode or program you select, the personal TV will allow you to enjoy the television program of your choice while you exercise.

**To upgrade your upright bike with a Workout TV console, call toll-free 1-877-363-8449.**

## HOW TO USE THE WORKOUT TV CONSOLE

The Workout TV console offers exactly the same features as the Basic console, but incorporates a built-in personal TV in addition. Note: The console has the capability to find and store in memory all of the valid TV channels in your area. You can even screen out unwanted channels. See pages 20 and 21 for instructions.

**A CATV cable must be connected to the upright bike in order for cable TV stations to be viewed.** See HOW TO CONNECT A CATV CABLE on page 10 for instructions.

**To use a Workout TV console, follow the instructions on pages 9 to 19 of this manual.** To use the personal TV, follow the instructions below.

### 1 Select the desired channel.

Press the CHANNEL + and – buttons to select a channel. The selected channel will appear in the main display.

Note: If a satellite receiver, VCR, or DVD player is connected, the channel must be changed at the satellite receiver, VCR, or DVD player.

### 2 Put on headphones (not included) if desired.

To listen to television programs using headphones, plug your headphones into the indicated jack on the top of the upright.

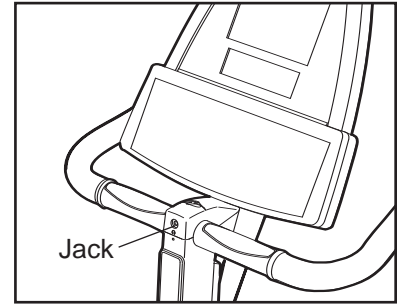

### 3 Adjust the volume.

Press the VOLUME + and – buttons to select the desired volume. The selected volume setting will appear in the main display.

# MAINTENANCE AND TROUBLESHOOTING

If you have questions about maintenance or troubleshooting, call Customer Care toll-free at 1-800-201-2109, Monday through Friday, 8 a.m. until 5 p.m. Mountain Time (excluding holidays).

Regularly inspect and properly tighten all external parts of the upright bike. To clean the upright bike, apply a small amount of mild multi-purpose cleaner to a 100% cotton cloth and wipe the console, screens, and external surfaces. **Do not spray cleaner directly onto the upright bike or use ammonia or acid-based cleaners.**

## LEVELING THE UPRIGHT BIKE

If the upright bike rocks slightly during use, see HOW TO MOVE AND LEVEL THE UPRIGHT BIKE on page 6.

## SEAT ADJUSTMENT

To adjust the position of the seat, see HOW TO ADJUST THE SEAT on page 6.

## SELECTING A SYSTEM OF MEASUREMENT

The console can display data using the standard system (miles and pounds) or the metric system (kilometers and kilograms). To change the system of measurement, see step 4 on page 20.

## PULSE SENSOR TROUBLESHOOTING

If the handgrip pulse sensor does not function properly, see step 6 on page 11.

## TV TROUBLESHOOTING

If the TV in the Workout TV console does not function properly, make sure that the included power cord is fully inserted (see HOW TO CONNECT THE POWER CORD on page 6). The power cord must be used for the TV to be operated.

If the TV picture is fuzzy, make sure that the correct connection setting is selected (see step 9 on page 20). In addition, make sure that the CATV cable is properly connected (see HOW TO CONNECT A CATV CABLE on page 7).



# EXERCISE GUIDELINES

## FACTORS IN A SENSIBLE DIET

- Choose high-fiber, low-fat, and low-sugar foods: fruits, vegetables, and whole grains.
- Eat at least five servings of fruits and vegetables daily.
- Reduce red meat consumption; eat lean meat, white meat, and fish.
- Choose healthful snacks; bring healthful foods with you to work or in the car.
- Eat regular meals or mini-meals. Control your portion size—don't binge or overeat. Eat slowly.
- Reduce fast food and pre-packaged meals.
- Pay attention to fat content and calories.
- Limit alcoholic beverages and caffeine.
- Drink at least eight to ten glasses of water daily.

## EXERCISE STEPS

The following nine steps for designing your exercise program were developed by exercise physiologists at NordicTrack. The actual exercise you perform is only a part of a safe and effective training program. There are many other aspects to developing a life-long commitment to physical fitness.

### 1 Consult your physician before beginning any exercise program.

A medical examination or consultation with your physician is essential.

### 2 Establish personal fitness goals.

Set attainable, realistic goals. Reward yourself when you meet your goals. Remember, your goals should act as a guide for your workout program.

### 3 Determine your target heart rate.

Your *target heart rate* (THR), is the rate at which you would like your heart to work during aerobic exercise. It is expressed as a percentage of your *maximum heart rate* (MHR). MHR is the maximum number of times that your heart can pump during one minute. To determine your approximate MHR, subtract your age (in years) from 220. This is only an estimation of your MHR—only clinical stress testing can provide an actual MHR reading.

Once you have determined your MHR, you can establish your target heart rate zone. Beginning exercisers may wish to start at 60 to 70 percent of their MHR. This level is called the *Health* level. Exercise at 70 to 85 percent of your MHR for the optimal training, aerobic, or cardiovascular level—the *Fitness* level. Advanced exercisers, or those wishing to do sports, athletic conditioning, or interval training workouts should exercise at 80 to 85 percent of the MHR for short periods of time. The chart below shows Target Heart Rate Zones for Health, Fitness, and Advanced exercisers.

Be sure to check your heart rate at least twice during an aerobic conditioning session. First, check your heart rate five minutes into your workout to be sure that you are at the proper intensity. Then, check it again near the end of your workout to verify that you have maintained your target heart rate for the recommended period of time.

TARGET HEART RATE ZONES

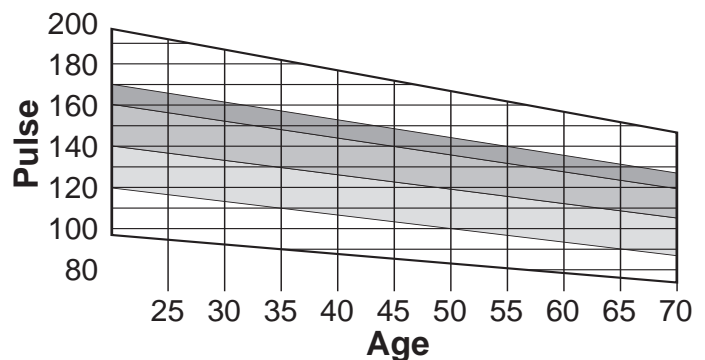

Health	Fitness	Advanced
Beginner, low-intensity + long duration = fat burning	Optimal training, aerobic or cardiovascular	Sports, athletic conditioning, interval training

## WEIGHT LOSS TIPS

At least four, 30-minute workouts per week, along with a reduced-calorie diet, are recommended if you are trying to lose weight. However, be sure to stay within your target heart rate zone and exercise a maximum of 5 days per week for 60 minutes per workout.

Good posture is the key to safe, comfortable workouts. Keep your chin up and your head facing forward. Align your head and shoulders with your hips. Avoid leaning forward. Keep your back straight.

### 4 Warm up before you begin.

A warm-up routine prepares your body and mind for vigorous exercise. It also helps provide insurance against injury and soreness. Warm up with two to five minutes of slow exercise, at minimal intensity.

### 5 Stretch after your warm-up.

A pliable, well-stretched muscle is less susceptible to injury. Perform the recommended stretches on a smooth, flat surface.

The correct form for several stretches is described below (see the drawings at the right). Be sure to move slowly as you stretch—never bounce.

**1. Toe Touch Stretch**—Sit with your knees bent slightly and slowly bend forward from your hips. Allow your back and shoulders to relax as you reach toward your toes as far as possible. Hold for 15 to 30 seconds, then relax. Repeat 3 times. Stretches: Hamstrings, back of knees, and back.

**2. Calf/Achilles Stretch**—With one leg in front of the other, reach forward and place your hands against a wall. Keep your back leg straight and your back foot flat on the floor. Bend your front leg, lean forward, and move your hips toward the wall. Hold for 15 to 30 seconds, then relax. Repeat 3 times for each leg. To cause further stretching of the achilles tendons, bend your back leg as well. Stretches: Calves, achilles tendons, and ankles.

**3. Hamstring Stretch**—Sit with one leg extended. Bring the sole of the opposite foot toward you and rest it against the inner thigh of your extended leg. Reach toward your toes as far as possible. Hold for 15 to 30 seconds, then relax. Repeat 3 times for both legs. Stretches: Hamstrings, lower back, and groin.

**4. Inner Thigh Stretch**—Sit with the soles of your feet together and your knees outward. Pull your feet toward your groin area as far as possible. Hold for 15 to 30 seconds, then relax. Repeat 3 times. Stretches: Quadriceps and hip muscles.

**5. Quadriceps Stretch**—With one hand against a wall for balance, reach back and grasp one foot with your other hand. Bring your heel as close to your buttocks as possible. Hold for 15 to 30 seconds, then relax. Repeat 3 times for each leg. Stretches: Quadriceps and hip muscles.

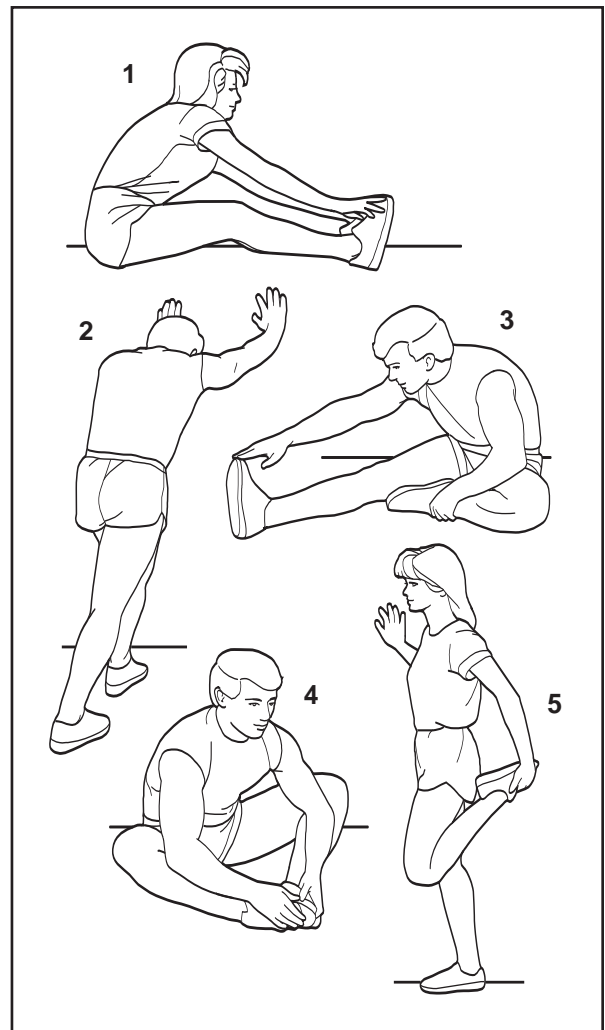

## BENEFITS OF AEROBIC EXERCISE

- Effective weight loss and management
- Added protection from heart disease
- Increased strength and health of bones
- Higher levels of energy for greater productivity during the day
- Healthy stress relief from a pressure-packed day
- Greater intellectual capacity and productivity

### 6 Get FIT with NordicTrack

Effective aerobic exercise has three major parts: *frequency*, *intensity*, and *time*. The acronym "FIT" may help you to remember these three parts:

**F** "F" stands for the frequency of your workouts. Three to five workouts per week are recommended. Exercise at least four times a week for weight loss.

**I** "I" refers to the intensity of your workout. Check your heart rate at least twice during your aerobic exercise session: once during the session and once again at the end. Maintain a workout intensity level within your Target Heart Rate Zone. You can measure your heart rate using the handgrip pulse sensor or the method described below:

1. Lower your wrist below your heart level. This will make your heart rate stronger and easier to feel.

2. Using the index and middle fingertips of your right hand, touch your left wrist, one-fourth inch from your wrist joint, at the base of your thumb.

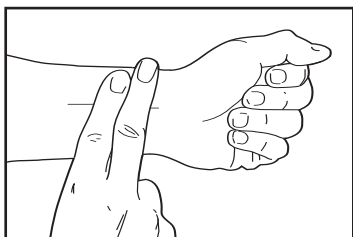

3. Apply minimal pressure with both fingers—let the beat come to your fingers. If you can't find your pulse, use the opposite wrist and hand.

**T** "T" is for the time or duration of your workout. Beginning exercisers may wish to start with 5 to 10 minutes of aerobic activity. Those in average physical condition should exercise for 20 to 30 minutes. Highly fit people, or people who want to lose weight, should exercise for 30 to 60 minutes. The key is to maintain your target heart rate for the duration of the workout period.

Remember to take it slowly. Fitness is a lifelong commitment. If you can't go the full 20 minutes from the start, which is common, try to exercise for five minutes at a time, a couple of times a day. Recent research indicates that several short workouts in one day can also provide fitness benefits. Gradually, your stamina will increase and it will become easier to exercise for longer periods of time.

### 7 Cool down after aerobic exercise.

Keep moving! It is important that you cool down properly to allow your heart rate to decrease slowly after it has been elevated. This helps the blood flow from your extremities back to your heart. Keep your legs moving on the upright bike at a slower pace for at least five minutes following the aerobic phase.

### 8 Stretch again at the end of your exercise session.

Stretching after exercise reduces muscle soreness. See step 5 on page 28.

### 9 Participate in strength training.

"Balanced fitness, including both strength training and aerobic exercise, can do more to ensure a happy life than just about anything else known to medical science today."

—Kenneth Cooper, M.D., M.P.H., founder of The Cooper Institute For Aerobic Research, Dallas, Texas.

A strength-training program increases your lean muscle mass. Lean muscle mass aids in burning body fat. With additional muscle mass and strength, you will receive the full benefits of an exercise program. You will also be less prone to injuries during the aerobic phase of your workout.

## WORKOUT TIPS

Full-body conditioning helps take care of many of life's aches and pains. However, it takes time for your body to adapt to any new routine. Below are some tips that will help ease you into your new NordicTrack routine.

- Begin and end each exercise session with the stretches on page 28. Stretch in a smooth, controlled manner. Hold each stretch for 15 to 30 seconds. You may experience some initial muscle soreness and discomfort as a result of exercising inactive or poorly stretched muscles. For maximum benefit, a stretching routine must be performed every day.
- Be aware of your body's signals and react to them accordingly. At your correct exercise intensity, you should be able to whistle or maintain a normal conversation. If during exercise you feel tired, light-headed, dizzy, or nauseated, stop exercising immediately and consult your physician. Your heart rate may also be affected by such things as stress, caffeine, nicotine, or prescription drugs.

## WORKOUT PROGRAMS

The *Health* level typically lasts four to six weeks. At this level you should be concerned with slowly improving your fitness level and endurance.

Take it slowly. Set mini-goals for yourself. You may want to begin your fitness routine with three or four short, 5- or 10-minute workouts in a day.

Move on to the *Fitness* Level only when you feel ready and your heart rate has moved below your target heart rate zone.

The *Fitness* level usually lasts 12 to 20 weeks. (It may last longer, depending on your fitness goals.) At this level you should strive to achieve your fitness goals.

Set realistic short- and long-term goals for yourself. Frequently re-evaluate your fitness goals and reward yourself as you are successful.

Move on to the *Advanced* Level when you have reached your fitness goals and your heart rate has moved below your target heart rate zone.

Work out at the *Advanced* level once you have reached your desired fitness goals. It is intended to be a maintenance program and should continue on a regular, long-term basis.

You may wish to add *Interval Training* to your maintenance program as well. Interval training will add variety to your workout routine and further condition your cardiovascular system. Interval training has been shown to promote higher levels of aerobic conditioning. It consists of spurts of high-intensity activity followed by active rest periods of exercise at a lower intensity. For example, a one-minute spurt of high-resistance, fast exercise is followed by a two- to three-minute active rest period of low-resistance, slow exercise. The duration of these periods should be based more on how you feel rather than time. A sequence such as this should be repeated 5 to 20 times during your workout session.

HEART RATE INTENSITY	Age	20	30	40	50	60	70	80
60% - 70% HEALTH	b.p.m.	120-140	114-133	108-126	102-119	96-112	90-105	84-98
70% - 85% FITNESS	b.p.m.	140-170	133-162	126-153	119-145	112-136	105-128	98-119
80% - 85% ADVANCED	b.p.m.	160-170	152-162	144-153	136-145	128-136	120-128	112-119



# LIMITED WARRANTY

## Limited Warranty on Commercial Equipment

FreeMotion Fitness, Inc. warrants that all new equipment will be free of manufacturing defects in workmanship and materials, becoming effective at the date of original installation. Parts repaired or replaced under the terms of this warranty will be warranted for the remainder of the original warranty period only. Labor must be performed at a FreeMotion Fitness commercial service facility or by a FreeMotion Fitness authorized commercial service provider.

### Terms and Conditions of Coverage

1. Warranty applies only while:
  - (A) it remains in the possession of the original purchaser and proof of purchase is demonstrated,
  - (B) it has not been subject to accident, misuse, abuse, improper service, or modification, and
  - (C) claims are made within the warranty period.
2. All coverage is provided by specific Product according to the guidelines listed on the chart below.
3. If the Product or any covered part must be returned to a service facility for repairs, We, FreeMotion Fitness, Inc., will pay all transportation and insurance charges for the first year. We must approve transportation and insurance previous to shipping. You are responsible for transportation and insurance charges during the remaining years.
4. We will ship to you any new or rebuilt replacement part or component, or, at our option, replace the Product. Such replacement parts are warranted for the remaining portion of the original warranty period.
5. This warranty does not cover damage or equipment failure caused by electric wiring not in compliance with electrical codes or FreeMotion Fitness owner's manual specifications, or failure to provide reasonable and necessary maintenance as outlined in the owner's manual. Any failures or damage caused by unauthorized service, misuse, accident, negligence, improper assembly or installation, debris resulting from any destruction activities in the Product's environment, rust or corrosion as a result of the Product's location, alterations or modifications without written authorization, or by failure on your part to use, operate, and maintain the Product as set in your owner's manual will void this warranty. **All terms of this warranty are void if this Product is moved beyond the continental borders of the United States of America (excluding Alaska, Hawaii, and Canada) and are then subject to the terms provided by that country's local authorized FreeMotion Fitness representative.**
6. During the labor period, FreeMotion Fitness, Inc. compensates Servicicers for warranty trips within their normal service area to repair Product at the consumer's location. You may be charged a trip charge outside the service area.
7. FreeMotion Fitness, Inc. Limited Warranty service may be obtained by contacting the authorized dealer from whom you purchased the Product, or by calling Customer Care at 1-800-201-2109.
8. Product limited warranty is void when Product is installed in a country other than where sold.

### Limited warranty does not apply to:

1. Repairs performed on Product with missing, altered, or defaced serial numbers.
2. Service calls to correct installation of the Product or instruct owners on how to use the Product.
3. Repair pick-up, delivery, or freight charges other than specified above.
4. Any labor costs incurred beyond the applicable labor warranty period.

### Lifetime Warranty

**Frame**—Excludes labor, handlebar assembly, bolted components, or attached components that are not welded to the base powder coated frame.

### Your Responsibility

Retain proof of purchase; use, operate, and maintain the Product as specified in the Owner's Manual; notify Customer Care of any defect within 10 days after discovery of the defect; if instructed, return any defective part for replacement, or, if necessary, the entire Product for repair.

### Owner's Manual

It is very important that you read the Manual before operating the Product. Remember to perform the periodic maintenance requirements specified in the Manual to assure proper operation and your continued satisfaction.

### Receipt of Parts and Service

Simply call Customer Care toll-free at 1-800-201-2109, Monday through Friday from 8 a.m. to 5 p.m. Mountain Time, and give your name, address, and the serial number of your Product. A representative will tell you how to get a replacement part, or, if necessary, arrange for service where your Product is located or advise you on how and where to ship the Product for service.

Before Shipping:

1. Obtain a Return Authorization Number (RA#) from Customer Care.
2. Securely pack your Product.
3. Write the RA# on the outside of the carton.
4. Insure the Product.
5. Include a letter explaining the defect or problem and a copy of your proof of purchase if you believe the service is covered by warranty.

### Exclusive Warranty

FreeMotion Fitness, Inc. is not responsible or liable for indirect, special, or consequential damages arising out of, or in connection with, the use or performance of the Product or damages with respect to any economic loss, loss of property, loss of revenues or profits, loss of enjoyment or use, costs of removal or installation, or other consequential damages of whatsoever nature. Some states do not allow the exclusion or limitation of incidental or consequential damages. Accordingly, the above limitation may not apply to you. The warranty extended hereunder is in lieu of any and all other warranties and any implied warranties of merchantability or fitness for a particular purpose is limited in its scope and duration to the terms set forth herein. Some states do not allow limitations on how long an implied warranty lasts. Accordingly, the above limitation may not apply to you.

### Unauthorized Changes to Warranty

No one is authorized to change, modify, or extend the terms of this limited warranty.

### State Laws

This warranty gives you specific legal rights and you may have other rights which vary from state to state.

Model	Lifetime	2 Years	1 Year	6 Months
CEX32531	Frame	Parts	Labor	Grips, labels, face plates, wheels
CEX35031	Frame	Parts	Labor	Grips, labels, face plates, wheels

# PART LIST—MODEL NOS. CEX32531, CEX35031

R0104A

To locate the parts listed below, see the EXPLODED DRAWING on pages 34 and 35.

Key No.	Qty.	Description	Key No.	Qty.	Description
1	1	Frame	38	8	Grip Insert
2	1	Control Board Cover	39	1	Pulse Jumper Wire
3	1	Upright	40	1	Pulse Board Return Wire
4	1	Console	41	1	Hand Pulse Sensor Wire
5	1	Seat Post	42	6	3/8" x 3/4" Screw
6	1	Audio Jack Cap	43	1	Chest Pulse Sensor Wire
7	1	Left Side Shield	44	1	Controller Wire
8	1	Right Side Shield	45	1	Power Wire
9	1	Seat Assembly	46	1	Generator Coil Wire
10	1	Seat Knob	47	1	Electromagnet Wire
11	2	Bottom Hand Pulse Grip	48	1	Power Supply
12	1	Accessory Tray	49	6	#8 Anchor Insert
13	1	Generator Assembly	50	2	Bottom Bracket Bolt
14	1	Idler Arm Assembly	51	4	#8 Standoff
15	1	Drive Belt	52	8	3/8" x 3/4" Button Screw
16	1	Control Board	53	4	3/8" x 1 1/4" Button Screw
17	1	Chest Pulse Sensor	54	2	5/16" x 1/2" Button Screw
18	2	Leveling Foot	55	2	#8 x 3/4" Screw
19	2	Frame Pad	56	2	#8 x 3/4" Phillips Pan Head Screw
20	1	TV Cable	57	1	#8 x 1/4" Socket Screw
21	1	Power Receptical	58	4	1/4" x 3/8 Socket Screw
22	1	Left Pedal	59	2	5/16" x 2" Button Screw
23	1	Right Pedal	60	1	3/8" x 3/4" Socket Screw
24	1	Left Pedal Strap	61	8	#6 x 1" Screw
25	1	Right Pedal Strap	62	1	1/4" x 3/8" Button Screw
26	2	Hand Grip	63	2	#4 x 1" Machine Screw
27	1	Left Crank Arm	64	4	#8 x 1/4" Nylon Screw
28	1	Right Crank Arm	65	10	#10 x 1/2" Machine Screw
29	1	Bottom Bracket	66	1	3/8" Washer
30	1	Pulley	67	2	Nylon Bushing
31	1	Bottom Bracket Adapter	68	1	Power Cord
32	1	Step Plate	69	4	#4 x 1/4" Screw
33	2	Wheel	70	2	#4 Standoff
34	2	Top Pulse Grip	71	1	Right Crank Arm Spacer
35	1	Idler Spring	#	1	User's Manual
36	1	Spring Bracket	#	1	3/16" Allen Wrench
37	8	Contact			

Note: “#” indicates a non-illustrated part. Specifications are subject to change without notice.

# EXPLODED DRAWING—MODEL NOS. CEX32531, CEX35031 R0104A

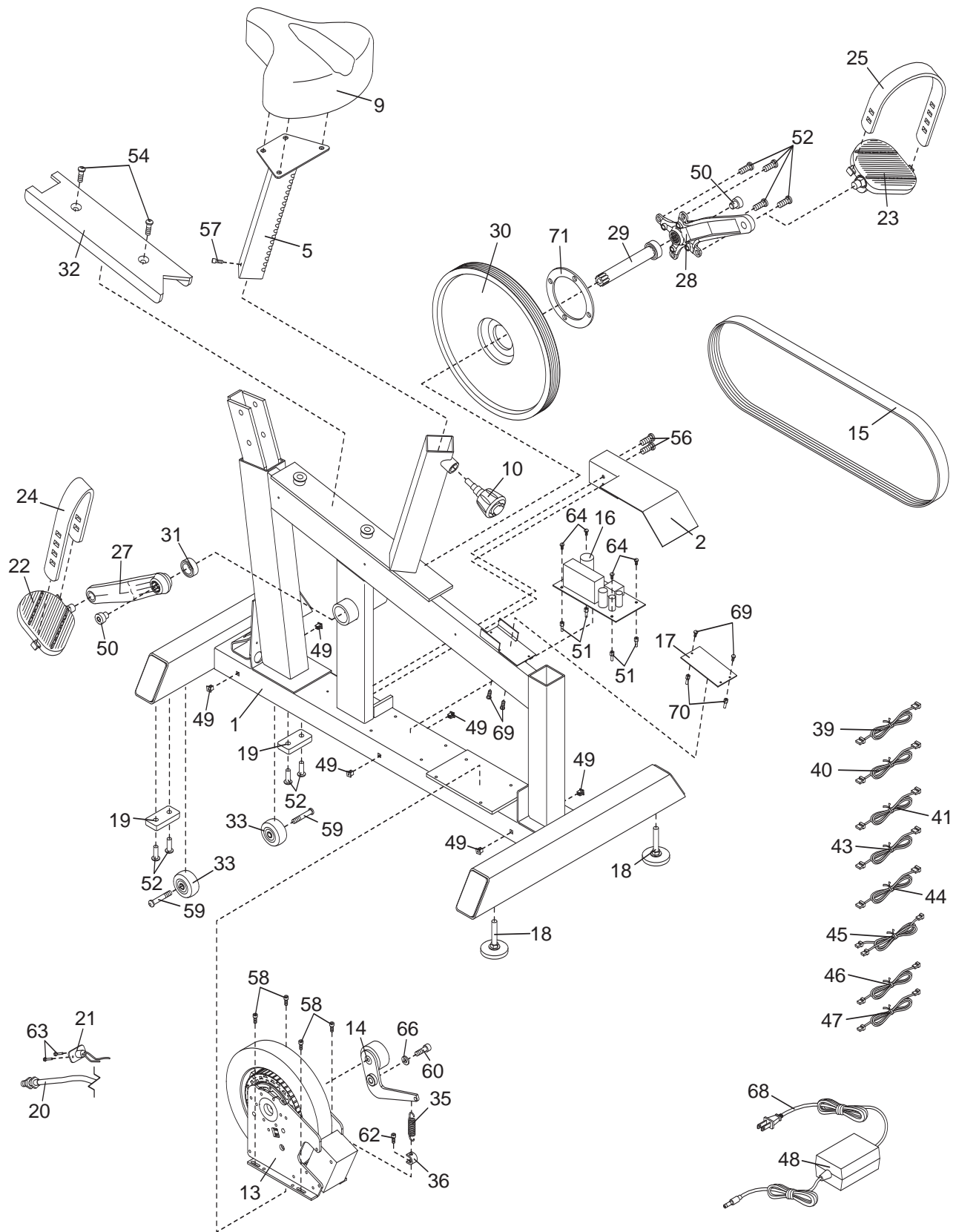

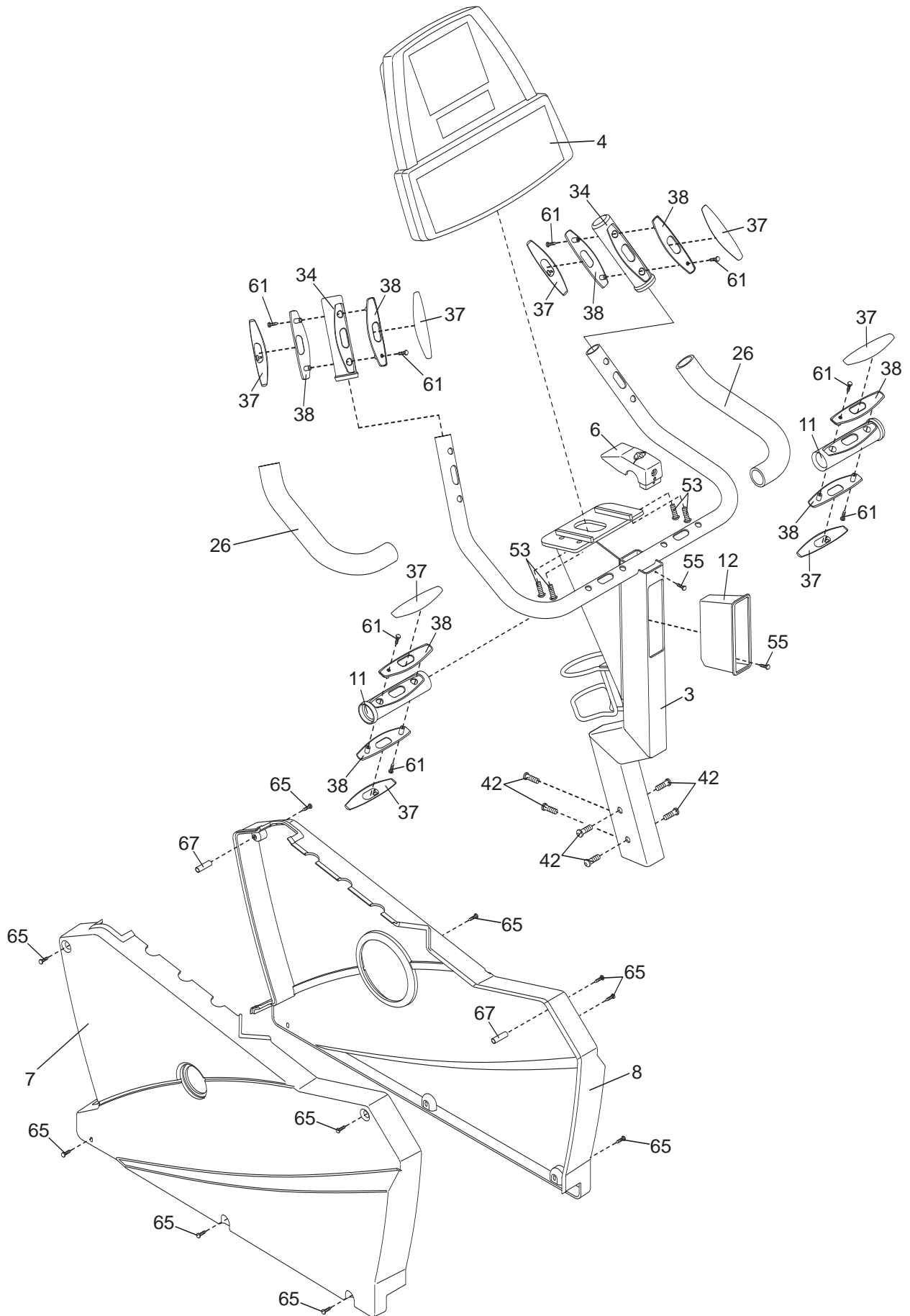

## HOW TO ORDER REPLACEMENT PARTS

To order replacement parts, call Customer Care toll-free at 1-800-201-2109, Monday through Friday, 8 a.m. until 5 p.m. Mountain Time (excluding holidays). When ordering parts, please be prepared to give the following information:

- The MODEL NUMBER OF THE PRODUCT (CEX32531 or CEX35031)
- The NAME OF THE PRODUCT (NordicTrack® 9600 upright bike)
- The SERIAL NUMBER OF THE PRODUCT (see the front cover of this manual for the location)
- The KEY NUMBER and DESCRIPTION OF THE PART(S) (see the PART LIST and the EXPLODED DRAWING on pages 33 to 35)



FreeMotion Fitness, Inc. • 1096 Elkton, Suite 600 • Colorado Springs, CO 80907