

STEVAL-IHP002V1: PLM smartplug demonstration board

Introduction

This demonstration board is a smartplug based on the STM32F10x microcontroller, ST7540 PLM, and STPM01 energy metering ICs. The board is a node of a PLM network which allows the final user to monitor and manage the plugged load energy consumption.

The board has been developed to provide a guideline to build a home/building automation subsystem for energy management. It is designed to fit the dimension of a standard box for wall installation and easy integration into home/building electrical plants. The current, power, energy and other information related to the electrical load connected to the smartplug board are sent to a PLM data concentrator through the home/building PLM network. The board includes the following functions shown in the block diagram of *Figure 1*:

- Energy measurement
- Power line communication up to 4.8 kbps
- RS232 connectivity
- Load driver with relay/Triac options
- Auxiliary relay output

Figure 1. Block diagram

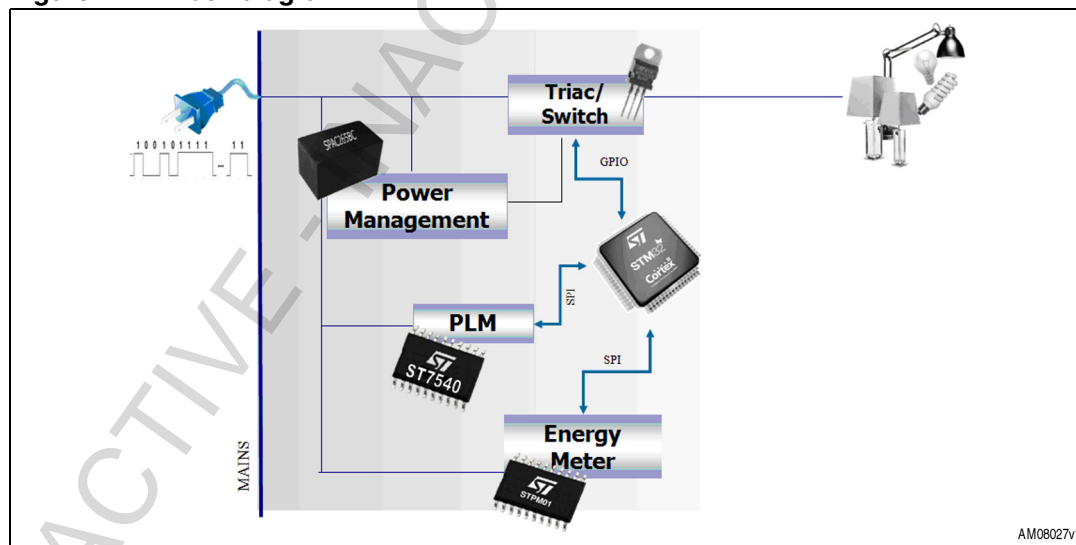

Contents

1	Overview	6
1.1	Recommended reading	6
1.2	Safety precautions	6
1.3	Getting technical support	6
1.4	Package checklist	6
2	PLM smartplug demonstration board components	8
2.1	Microcontroller	8
2.2	Debug	8
2.3	Reset	8
2.4	Power supplies	8
2.5	Power line communication	8
2.6	Energy measurement	9
2.7	Load drivers	10
2.8	RS32 serial communication	10
2.9	General purpose configuration	11
2.10	Status LEDs	11
2.11	Jumpers	11
2.11.1	Jumper placement	11
2.11.2	Jumper positions	12
2.11.3	Jumper description and default value	12
2.12	Pushbutton description	13
2.13	Connector description	13
3	Connectors	14
3.1	STM32 JTAG connector	14
3.2	Energy meter IC calibration connector	14
4	Board configuration	15
4.1	Boot	15
4.2	STPM01 calibration configuration	15
4.3	STPM01 data line configuration	15

5	Bill of material	16
6	Schematics	26
7	Revision history	33

INACTIVE - INACTIVE - INACTIVE

List of tables

Table 1.	STM32 resources – ST7540 function mapping	9
Table 2.	STM32 resources – STPM01 function mapping	10
Table 3.	STM32 resources – RS232 function mapping	10
Table 4.	STM32 resources – configuration jumpers mapping	11
Table 5.	LED description	11
Table 6.	Jumper description	12
Table 7.	Pushbutton description	13
Table 8.	Connector description	13
Table 9.	STPM01 calibration connector description	14
Table 10.	Boot modes	15
Table 11.	BOM list	16
Table 12.	Document revision history	33

INACTIVE - INACTIVE - INACTIVE

List of figures

Figure 1.	Block diagram	1
Figure 2.	PLM smartplug board	7
Figure 3.	Wiring diagram	9
Figure 4.	Jumper placement	11
Figure 5.	Jumper positions	12
Figure 6.	Auto-calibration mode connection diagram	13
Figure 7.	STM32 JTAG connector	14
Figure 8.	STPM01 calibration connector	14
Figure 9.	Top page	26
Figure 10.	RS232 communication section	27
Figure 11.	Power supply section	28
Figure 12.	Power line communication section	29
Figure 13.	MCU section	30
Figure 14.	Energy meter	31
Figure 15.	Output drivers	32

1 Overview

1.1 Recommended reading

This document describes how to configure and use the PLM smartplug demonstration board. Additional information can be found in the following documents:

- ST devices datasheets referenced in this document
- Third party device datasheets
- AN3287 application notes
- UM1006 user manual.

1.2 Safety precautions

The board must be used only by expert technicians. Due to the high voltage (220 Vac) special care should be taken with regard to human safety.

There is no protection against accidental human contact with high voltages.

After disconnection of the board from the mains, none of the live parts should be touched immediately because of the energized capacitors.

It is mandatory to use a mains insulation transformer to perform any tests on the board in which test instruments such as spectrum analyzers or oscilloscopes are used.

Do not connect any oscilloscope probes to high voltage sections in order to avoid damaging instruments and demonstration tools.

Warning: ST assumes no responsibility for any consequences which may result from the improper use of this tool

1.3 Getting technical support

Technical assistance is provided free to all customers. For technical assistance, documentation, upgrades and information about products and services, please refer to your local ST distributor/office.

1.4 Package checklist

The PLM smartplug demonstration board package includes the following items:

- The PLM smartplug demonstration board ([Figure 2](#))
- A CD-ROM with software and documentation

Figure 2. PLM smartplug board

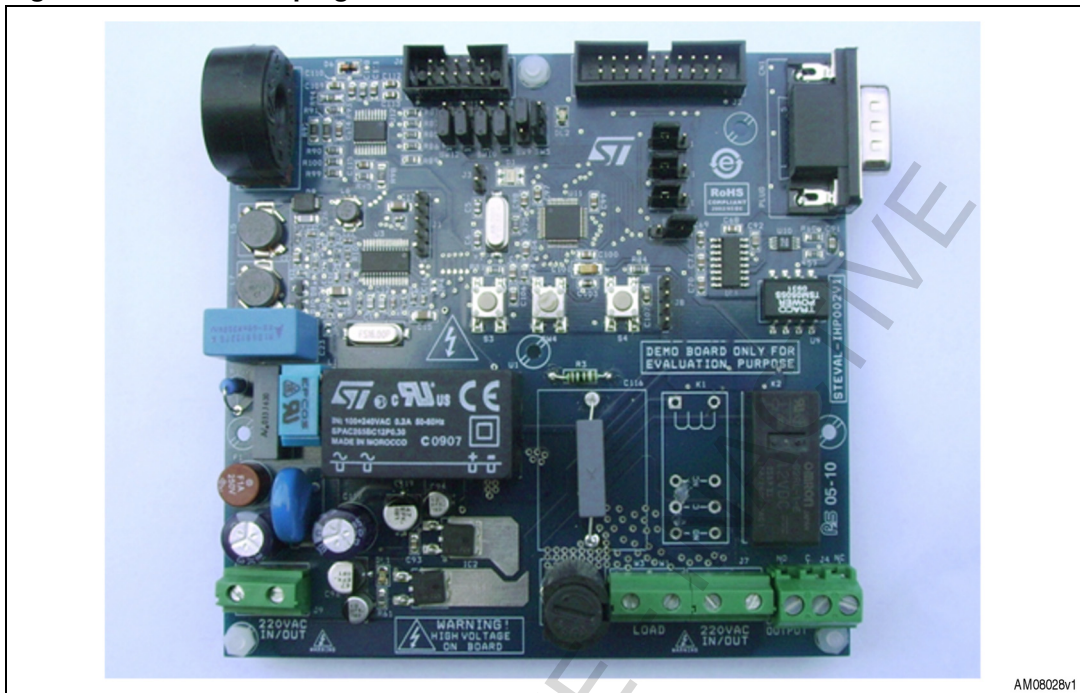

AM08026v1

2 PLM smartplug demonstration board components

2.1 Microcontroller

The system is managed by the STM32F103CB microcontroller. It is based on the 32-bit ARM Cortex -M3 core with 72 Mhz maximum frequency, 128 KB flash and 20 KB SRAM embedded memories. For further details please refer to the STM32F103x4 STM32F103x6 and the STM32F103x8 STM32F103xB datasheets.

The microcontroller is driven by an external 8 MHz crystal for the high speed main clock. Some jumpers are connected to the microcontroller GPIOs in order to allow firmware configuration.

2.2 Debug

Software debug is via a standard 20-pin JTAG connection. The JTAG connector is not insulated, so for debugging use the JTAG opto-insulation board (order code: AI-JTAG/OPTO-1/A), a battery supplied notebook, or supply the board through an insulated AC source.

2.3 Reset

The Reset sources are:

- Power on reset
- Pushbutton reset
- JTAG reset from an in-circuit emulator

2.4 Power supplies

The board is powered directly by the mains. It includes an insulated extended range power supply and both 50 Hz and 60 Hz frequencies.

The power supply consists of an SPAC265-3W AC/DC module; it provides 12 Vdc with 250 mA maximum current. The 5 Vdc and the 3.3 Vdc are generated by an LD1117XX50 and an LD1117ADT33TR linear regulator starting from 12 Vdc.

2.5 Power line communication

The board allows digital data communication through power line modulation using the ST7540 power line modem. For more details about the modem please refer to the ST7540 datasheet. The ST7580 supports B-FSK modulation up to 4800 bps; it is compliant with CENELEC band A, B, and C, supports preamble and unique word reception synchronization, and has a 500 mArms output current with 12 Vpp single-ended thanks to its integrated amplifier. The modem is coupled with the mains by a non-insulated topology using a capacitor. The ST7540 is managed by an SPI and two control lines: the REG_DATA line, which is used to select the access to the configuration register or to the data, and the RxTx line which is used to select the reception or transmission mode. Moreover, the ST7540 provides information about the preamble/unique-word detection (CD/PD) and the carrier

sensing (BU) by two digital outputs. [Table 1](#) shows the MCU resources mapping used for ST7540 management:

Table 1. STM32 resources – ST7540 function mapping

STM32 resource	ST7540 function
PA1	REG_DATA
PA2	CD/PD
PA3	BU
PA4	RxTx
SPI1-SCK (PA5)	SCK
SPI1-MISO (PA6)	TXD
SPI1-MOSI (PA7)	RXD

2.6 Energy measurement

The energy meter section is based on the STPM01 programmable single-phase energy meter IC. The STPM01 supports 50÷60 Hz - IEC62052-11, IEC62053-2X specifications with less than 0.1 % error. For further details please refer to the STPM01 datasheet. The current sensing is done by the current transformer; the STPM01 also measures the mains voltage. The image in [Figure 3](#) shows the wiring diagram.

Figure 3. Wiring diagram

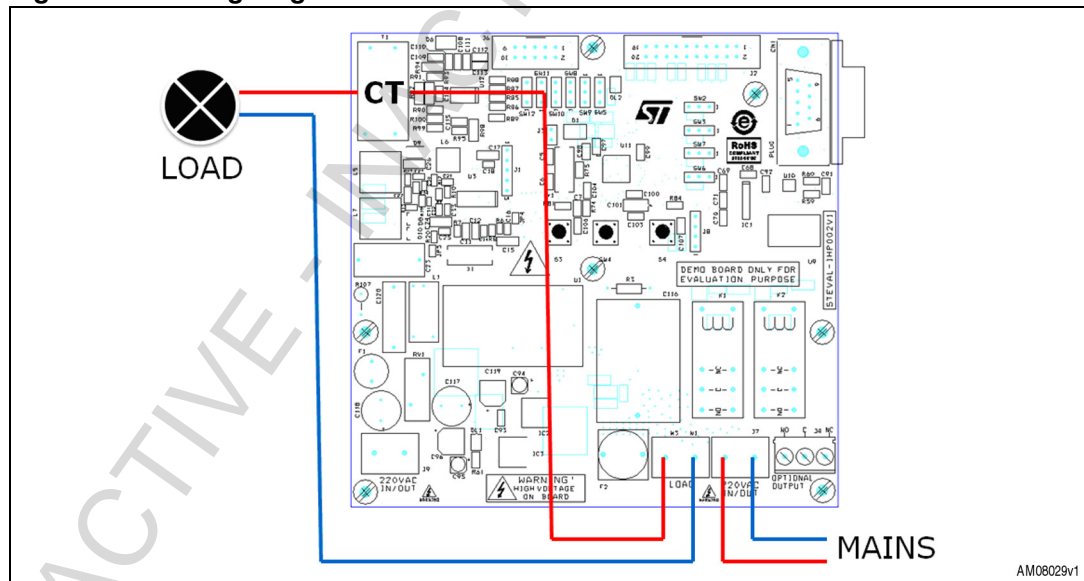

The STPM01 is controlled by the MCU with an SPI communication bus and digital control line. [Table 2](#) shows the MCU resources mapping for energy meter IC management:

Table 2. STM32 resources – STPM01 function mapping

STM32 resource	Energy meter function
PA11	SYN
SPI2-MOSI/MISO (PB15/PB14)	SDA
SPI2-SCK (PB13)	SCL
PB12	SCS

2.7 Load drivers

The smartplug can supply 110/230 Vac - 50/60 Hz mono-phase resistive load with 16 A maximum current. It offers two different options to drive the load:

- ON/OFF by a relay
- Dimming by Triac

The default configuration is the dimming one. Configuration selection is done by changing the fitted component into the output section of the board, as described in the following:

- ON/OFF configuration: fit only R104, Q4, D12, k1, C116, R3
- Dimming configuration: fit only R104, Q4, R101, D11, C1, R102, Q3, C116, R3

Moreover, as far as the ON/OFF configuration is concerned, depending on whether R103 is fitted or not, it is possible to have the output contacts as:

- Normally open (N.O.), if R103 is fitted
- Normally closed (N.C.), if R103 is not fitted (default configuration)

The board also includes an auxiliary independent 16 A relay output for general purpose function, in fact, the relay contacts are not connected to the AC input.

2.8 RS32 serial communication

The board includes an insulated RS232 serial communication interface which could be used as a runtime debugging port. [Table 3](#) shows the MCU resources mapping:

Table 3. STM32 resources – RS232 function mapping

STM32 resource	Serial communication function
USART1-TX (PA9)	RS232-TX
USART1-RX (PA10)	RS232-RX

2.9 General purpose configuration

The boards support three general purpose configuration jumpers for the STM32 firmware, [Table 4](#) shows the resource mapping:

Table 4. STM32 resources – configuration jumpers mapping

STM32 resource	Jumpers
PB5	CONF0
PB6	CONF1
PB7	CONF2

2.10 Status LEDs

Table 5. LED description

LED	Description
DL1	5 V power supply
D1	General purpose bi-color
DL2	Energy measurement

2.11 Jumpers

2.11.1 Jumper placement

Figure 4. Jumper placement

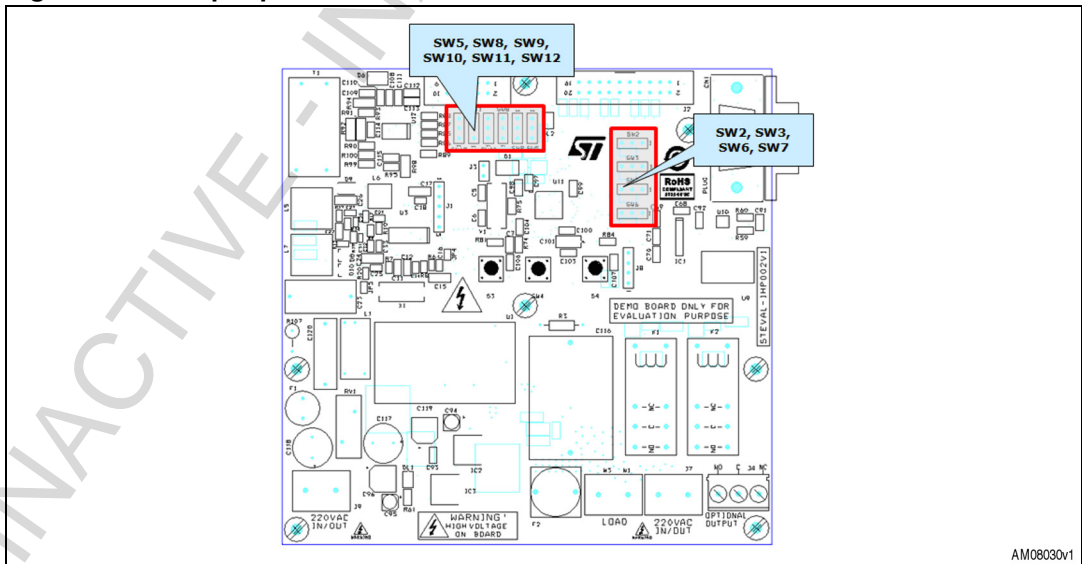

2.11.2 Jumper positions

Figure 5. Jumper positions

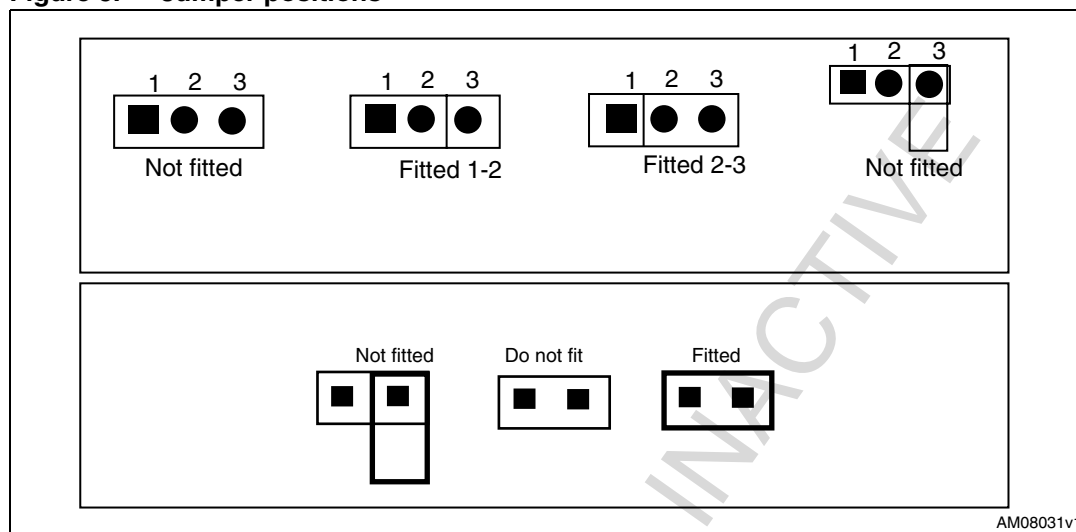

2.11.3 Jumper description and default value

Table 6. Jumper description

Jumper	Description	Default
SW2, SW5	Boot option - Fitted (1-2): boot option bit 0 - Fitted (2-3): boot option bit 1	Fitted (1-2)
SW3, SW6, SW7,	General purpose configuration bit - Fitted (1-2): configuration bit 1 - Fitted (2-3): configuration bit 0	Fitted (2-3)
SW8, SW10, SW11, SW12	STPM01 calibration mode - Fitted (1-2): normal mode - Fitted (2-3): calibration mode	Fitted (1-2)
SW9	Energy meter data line option - Fitted (1-2): data line connected to SPI2-MISO - Fitted (2-3): data line connected to SPI2-MOSI	Fitted (1-2)

2.12 Pushbutton description

Table 7. Pushbutton description

Switch	Description
S3	General purpose button
S4	General purpose button
SW4	STM32 reset button

2.13 Connector description

Figure 6. Auto-calibration mode connection diagram

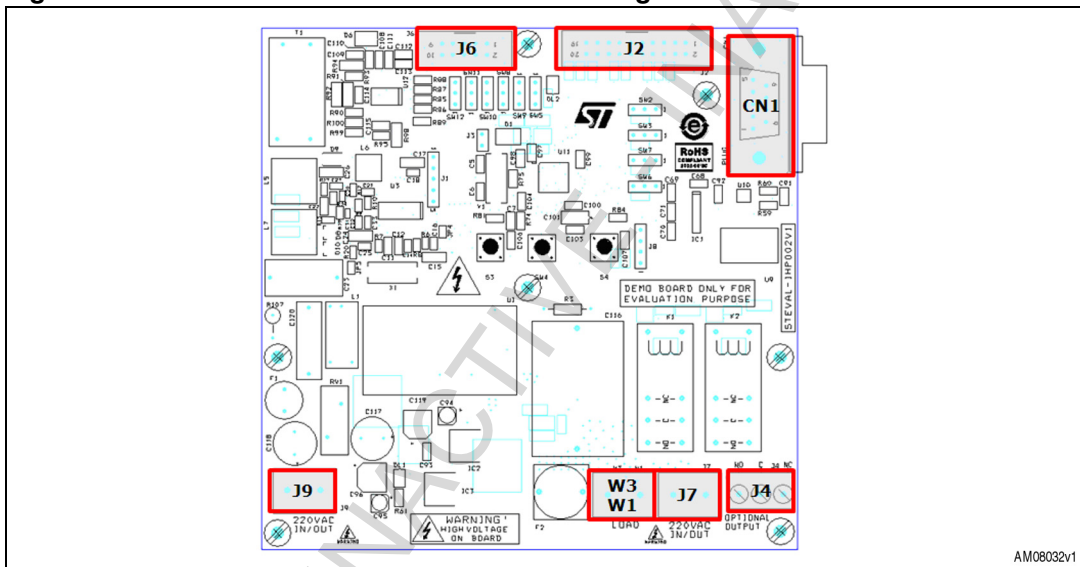

Table 8. Connector description

Connector	Description
J6	STPM01 calibration connector
J2	JTAG connector for STM32
CN1	RS232 connector
J9	220 VAC IN/OUT
W3 W1	AC LOAD connector
J7	220 VAC IN/OUT
J4	Auxiliary relay output

3 Connectors

3.1 STM32 JTAG connector

Figure 7. STM32 JTAG connector

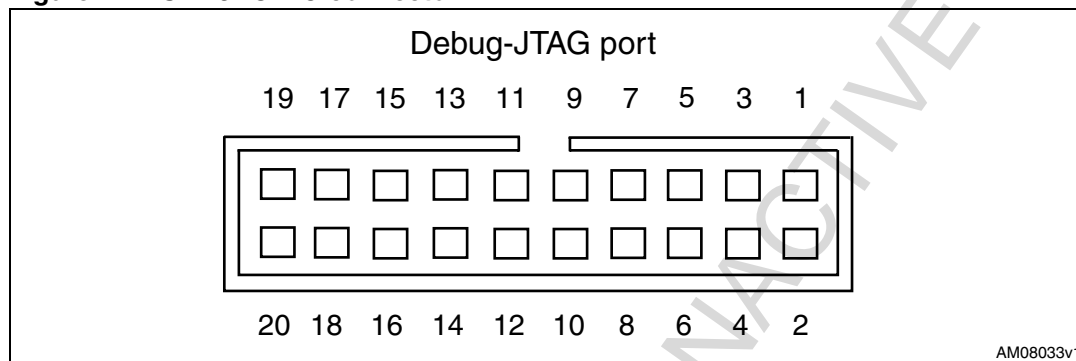

3.2 Energy meter IC calibration connector

Figure 8. STPM01 calibration connector

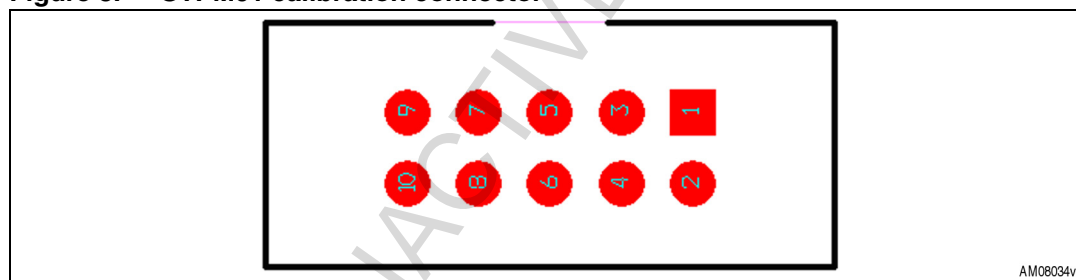

Table 9. STPM01 calibration connector description

Pin	Description	Pin	Description
1	VOTP	6	SCLK_CAL
2	SBG	7	LED
3	GND	8	SYN_CAL
4	SDA_CAL	9	SBG
5	SCS_CAL	10	Not connected

4 Board configuration

4.1 Boot

The board allows configuration of the boot options of the STM32 by setting the jumpers SW5 and SW2: SW2 drives BOOT0 and SW5 drives BOOT1.

Table 10. Boot modes

Boot mode selection pins		Boot mode	Aliasing
BOOT1	BOOT0		
x	0	Main Flash memory	Main Flash memory is selected as boot space
0	1	System memory	System memory is selected as boot space
1	1	Embedded SRAM	Embedded SRAM is selected as boot space

4.2 STPM01 calibration configuration

To calibrate the STPM01, the SW8, SW10, SW11, and SW12 must be set according to [Table 6](#). When these switches are set in calibration mode, the STPM01 can be driven by an external programmer using the connector J6.

4.3 STPM01 data line configuration

It is possible to configure if using the SPI2 MOSI or SPI2 MISO as the energy meter data line, setting SW9 according to [Table 6](#).



5 Bill of material

Table 11. BOM list

Reference	Part / value	Tolerance %	Voltage current	Watt	Technology information	Package-foot-print	Manufacturer	Manufacturer code	RS/Distelec/ other code	More info
CN1	PORT 0				9-way r/a PCB D plug, US footprint 8.1mm	Through hole	Any		RS code: 160-2590	
C1	2.2 μ F	+/-10 %	50 V		Ceramic capacitor X7R	SMD 0805				
C5,C6	22 pF	+/-10 %	50 V		Ceramic capacitor X7R	SMD 0805				
C7	470 nF	+/-10 %	50 V		Ceramic capacitor X7R	SMD 0805				
C11, C12	33 pF	+/-10 %	50 V		Ceramic capacitor X7R	SMD 0805				
C14, C27, C103	10 nF	\pm 10 %	50 V		Ceramic capacitor X7R	SMD 0603	muRata	GRM188R71H103KA01D	RS code: 204-0779	
C114, C115	10 nF	+/-10 %	50 V		Ceramic capacitor X7R	SMD 0805				
C15, C17, C24	10 μ F	\pm 10 %	16 V		Ceramic capacitor X7R	SMD 1206	Kemet	C1206C106K4PA C7800	RS code: 648-0755	
C16, C18, C25	100 nF	\pm 10 %	50 V		Ceramic capacitor X7R	SMD 0603	muRata	GRM188R71H104KA93D	RS code: 624-2480	
C22	10 μ F	\pm 10 %	10 V		Ceramic capacitor X5R	SMD 0805	muRata	GRM21BR61A106KE19L	RS code: 106-846	
C116	47 nF	+/-10 %	300 V		X2 Capacitor	Through Hole	Any		RS code: 441-9600	
C101	10 μ F	10 %	10 V		Tantalium capacitor	SMD	Any		RS code: 464-7619	

Table 11. BOM list (continued)

Reference	Part / value	Tolerance %	Voltage current	Watt	Technology information	Package-foot-print	Manufacturer	Manufacturer code	RS/Distelec/ other code	More info
C23	68 nF	±20 %	300 V		X2 Capacitor	Through Hole	Any		Distelec code: 821885	
C26	6.8 nF	±5 %	50 V		Ceramic capacitor COG	SMD 1206	muRata	GRM3195C1H682JA01D	RS code: 624-2597	
C30	15 pF	±5 %	50 V		Ceramic capacitor COG	SMD 0402	muRata	GRM1555C1H150JZ01D	RS code: 624-2935	
C31	22 pF	±5 %	50 V		Ceramic capacitor COG	SMD 0402	muRata	GRM1555C1H220JZ01D	RS code: 624-2187	
C32	270 pF	±5 %	50 V		Ceramic capacitor COG	SMD 0603	Kemet	C0603C271J5GAC7867	RS code: 147-207	
C21,C33	100 pF	±5 %	50 V		Ceramic capacitor COG	SMD 0603	muRata	GRM1885C1H101JA01D	RS code: 653-0327	
C68, C69, C70, C71, C102, C105, C106, C107, C93, C97, C98, C99, C100, C104, C109, C110, C111, C112, C113	100 nF	+/-10 %	50 V		Ceramic capacitor X7R	SMD 0805				
C91, C92	47 nF	+/-10 %	50 V		Ceramic capacitor X7R	SMD 0805				
C94, C95	10 µF	+/-20 %	50 V		Electrolytic capacitor	SMD	Any		RS code: 536-9859	

**Table 11. BOM list (continued)**

Reference	Part / value	Tolerance %	Voltage current	Watt	Technology information	Package-foot-print	Manufacturer	Manufacturer code	RS/Distelec/ other code	More info
C108	1 nF	+/-10 %	50 V		Ceramic capacitor X7R	SMD 0805				
C117,C118	470 µF	+/-20 %	25 V		Electrolytic capacitor low ESR	Through hole	Any		Distrelec code: 801846	
C96, C119	47 µF	+/-20 %	25 V		Electrolytic capacitor	SMD	Any		RS code: 565-712	
C120	33 nF	+/-10 %	275 V		X2 capacitor	Through hole	Any		RS code: 118-148	
DL1	Red				Chip LED	SMD 0805	Any		Distrelec code: 250154	
DL2	Blue				Chip LED	SMD 0805	Any		Distrelec code: 250159	
D1	Bi-color LED red / green				LED Bi-Red, Green	SMD	Any		RS code: 419-053	
D6, D12, D13	LL4148				Switching diode_	SOD-80	Any		Distrelec code: 601496	
D8, D10	BAT54S				Small signal Schottky diodes	SOT-23	STMicroelectronics	BAT54SFILM		
D9	SM6T15 CA				Transil	SMB	STMicroelectronics	SM6T15CA		
D11	STPS14 0U				Power Schottky rectifier	SMB	STMicroelectronics	STPS140U		
F1	1 A				TR5 anti-surge submin PCB T fuse	Through hole	Any		RS code: 611-0658	
F2	15 A		250 V/15 A		Min fuse 15 A 5x20 mm				RS code: 541-4599	

Doc ID 18006 Rev 1

18/34

UM1005

Bill of material

Table 11. BOM list (continued)

Reference	Part / value	Tolerance %	Voltage current	Watt	Technology information	Package-foot-print	Manufacturer	Manufacturer code	RS/Distelec/ other code	More info
Socket for F2					Socket for F2	Through hole	Wickmann	652	Distelec code: 273260	
Cap for socket	Cap for socket				Cap for socket		Wickmann	655	Distelec code: 273262	
IC1	ST3232 EBDR				RS-232 drivers and receivers	SO-16	STMicroelectronics	ST3232EBDR		
IC2	LD1117 DT50TR				Low drop fixed and adjustable positive voltage regulators	DPAK	STMicroelectronics	LD1117DT50TR		
IC3	LD1117 ADT33TR				Low drop fixed and adjustable positive voltage regulators	DPAK	STMicroelectronics	LD1117ADT33TR		
JP4, JP5	Close				Do not fit	Do not fit	Do not fit	Do not fit	Do not fit	
J1	Peak meter connector				5-way single-row strip line connector (male connector) 2,54 mm pitch	Vertical through hole	Any		RS code:495-8470	
J8	Rfid reader				4-way single-row strip line connector (male connector) 2,54 mm pitch	Vertical through hole	Any		RS code:495-8470	
J2	JTAG				20-way IDC low profile boxed header 2,54 mm pitch	Vertical through hole	Any		RS code: 461770	

**Table 11. BOM list (continued)**

Reference	Part / value	Tolerance %	Voltage current	Watt	Technology information	Package-foot-print	Manufacturer	Manufacturer code	RS/Distrelec/ other code	More info
J3	CON2				2-way single-row strip line connector (male connector) 2.54 mm pitch	Vertical through hole	Any		RS code:495-8470	
J4	CON3				3-way screw terminal block 5.08 mm pitch	Through hole	Any		RS code:189-5865	
J6	CAL CON				10-way IDC low profile boxed header 2.54 mm pitch	Vertical through hole	Any		RS code: 461-742	
J7, J9	CON2				2-way screw terminal block 7.5 mm pitch	Through hole	Phoenix Contact	1988105	RS code: 548-7301	
L1	2x10 mH		0.5 A		Line filter	Through hole	Any		Distrelec code: 351276	
L5	22 μ H	± 10 %	2.1 A		Smd inductor	SMD	EPCOS	B82464A4223K	RS code: 496-0445	
L6	220 μ H	± 10 %	240 mA		Smd inductor	SMD	EPCOS	B82462A4224K	RS code: 495-8048	
L7,L9	1 mH	± 10 %	330 mA		Smd inductor	SMD	EPCOS	B82464A4105K	RS code: 496-0530	
L8	10 μ H	± 10 %	1 A		Smd inductor	SMD	EPCOS	B82442H1103K	RS code: 496-1268	
Q1, Q2	BC857B				PNP transistor	SOT23	Any		RS code: 445-2051	



Table 11. BOM list (continued)

Reference	Part / value	Tolerance %	Voltage current	Watt	Technology information	Package-foot-print	Manufacturer	Manufacturer code	RS/Distelec/ other code	More info
Q3	T2035H				High temperature 20 A Snubberless™ Triacs	D2PAK	ST Microelectronics	T2035H-6G-TR		
Q4, Q5	2STR12 15				Low voltage fast-switching NPN power transistor	SOT-23	ST Microelectronics	2STR1215		
R3	1 kΩ	+/-5 %		1/2 W	Resistor	Axial through hole				
R6	1.1 kΩ	+/-1 %		0.1 W	Resistor	SMD 0603				
R7	47 kΩ	+/-1 %		0.1 W	Resistor	SMD 0603				
R8	15 kΩ	+/-1 %		0.1 W	Resistor	SMD 0603				
R9	4.7 kΩ	+/-1 %		0.1 W	Resistor	SMD 0603				
R88, R108, R109	4.7 kΩ	+/-5 %		1/8 W	Resistor	SMD 0805				
R10	13 kΩ	+/-1 %		0.1 W	Resistor	SMD 0603				
R12	1 kΩ	+/-1 %		0.1 W	Resistor	SMD 0603				
R62, R68, R104, R106	1 kΩ	+/-5 %		1/8 W	Resistor	SMD 0805				
R13	2.7 kΩ	+/-1 %		0.1 W	Resistor	SMD 0603				
R14	1.8 kΩ	+/-1 %		0.1 W	Resistor	SMD 0603				
R17	470 Ω	+/-1 %		0.1 W	Resistor	SMD 0603				
R19	2.4 kΩ	+/-1 %		0.1 W	Resistor	SMD 0603				
R85, R86, R87	2.4 kΩ	+/-5 %		1/8 W	Resistor	SMD 0805				
R20	56 kΩ	+/-1 %		0.1 W	Resistor	SMD 0603				

**Table 11. BOM list (continued)**

Reference	Part / value	Tolerance %	Voltage current	Watt	Technology information	Package-foot-print	Manufacturer	Manufacturer code	RS/Distelec/ other code	More info
R21, R96, R97	261 k Ω	+/-1 %		1/4 W	Resistor	SMD 1206				
R59, R60	0	+/-5 %		1/8 W	Resistor	SMD 0805				
R61, R89	560 Ω	+/-5 %		1/8 W	Resistor	SMD 0805				
R63, R64, R65, R66, R71, R72, R73, R74, R76, R77, R80, R81, R82, R83, R84	10 k Ω	+/-5 %		1/8 W	Resistor	SMD 0805				
R67	(Not mounted)	+/-5 %		1/8 W	Resistor	SMD 0805				
R69, R70	82 Ω	+/-5 %		1/4 W	Resistor	SMD 1206				
R75	1 M Ω	+/-5 %		1/8 W	Resistor	SMD 0805				
R91, R92	6.8 Ω	+/-1 %		1/4 W	Resistor	SMD 1206				
R94	2 M Ω	+/-1 %		1/8 W	Resistor	SMD 0805				
R98	475 Ω	+/-1 %		1/4 W	Resistor	SMD 1206				
R99	43 k Ω	+/-1 %		1/8 W	Resistor	SMD 0805				
R100	100 Ω	+/-1 %		1/8 W	Resistor	SMD 0805				
R101	1 k Ω	+/-1 %		1/4 W	Resistor	SMD 1210				
R102	22 Ω	+/-1 %		1/4 W	Resistor	SMD 1210				
R103, R105	1 k Ω (do not fit)	+/-1 %		1/4 W	Resistor	SMD 1210				
R90, R93	1 k Ω	+/-1 %		1/8 W	Resistor	SMD 0805				

Table 11. BOM list (continued)

Reference	Part / value	Tolerance %	Voltage current	Watt	Technology information	Package-foot-print	Manufacturer	Manufacturer code	RS/Distelec/ other code	More info
R95	0	+/-1 %		1/8 W	Resistor	SMD 0805				
R107	10	5 %		1 W	Fuse resistor	Axial through hole	Any		RS code: 214-0879	
RV1	S14K510	10 %	510 VAC		Disk-shaped metal-oxide varistors	Through hole	EPCOS	B72214S0511K101	Distelec code: 730933	
SW2	BOOT_0				3-way single-row strip line connector (male connector) 2.54 mm pitch	Vertical through hole	Any		RS code:495-8470	Single strip line 3 poles
SW3	CONF3				3-way single-row strip line connector (male connector) 2.54 mm pitch	Vertical through hole	Any		RS code:495-8470	Single strip line 3 poles
SW4	Rst				Surface mount tactile switch	SMD	Any		RS code 183701	
SW5	BOOT_1				3-way single-row strip line connector (male connector) 2.54 mm pitch	Vertical through hole	Any		RS code:495-8470	Single strip line 3 poles
SW6	CONF0				3-way single-row strip line connector (male connector) 2.54 mm pitch	Vertical through hole	Any		RS code:495-8470	Single strip line 3 poles

**Table 11. BOM list (continued)**

Reference	Part / value	Tolerance %	Voltage current	Watt	Technology information	Package-foot-print	Manufacturer	Manufacturer code	RS/Distelec/ other code	More info
SW7	CONF1				3-way single-row strip line connector (male connector) 2.54 mm pitch	Vertical through hole	Any		RS code:495-8470	Single strip line 3 poles
SW8, SW9, SW10, SW11, SW12	Calibration settings				3-way single-row strip line connector (male connector) 2.54 mm pitch	Vertical through hole	Any		RS code:495-8470	Single strip line 3 poles
S3,S4	SW push				Surface mount tactile switch	SMD	Any		RS code 183701	
TP8,TP9, TP10,TP11 ,TP12, TP13,TP14 ,TP15, TP16,TP17 ,TP18, TP19,TP20 ,TP21, TP22,TP23 ,TP25, TP26,TP27	Test point				Test point	Test point	Test point	Test point	Test point	
T1	Current transformer				Current Transformer	Through Hole	VAC	T60404-E 4622-X503		
U1	SPAC26 5-3W				AC-DC switch mode power supply	Through hole	ST Microelectronics	SPAC265BC12P 0.30		
U3	ST7540				FSK power line transceiver	HTSSOP28	ST Microelectronics	ST7540TR		

Table 11. BOM list (continued)

Reference	Part / value	Tolerance %	Voltage current	Watt	Technology information	Package-foot-print	Manufacturer	Manufacturer code	RS/Distelec/ other code	More info
U9	TSM050 5S				DC-DC converter	SOIC-14	Traco Power	TSM0505S	RS code: 510-5431	
U10	IL712S-1E				Bi-directional Digi Isolator	MSOP8	NVE	IL712S-1E	RS code: 418-436	
U11	STM32F103CBT6				Medium-density performance line ARM-based 32-bit MCU	LQFP48	ST Microelectronics	STM32F103CBT6		
U12	STPM01				Programmable single-phase energy metering IC with tamper detection	TSSOP20	ST Microelectronics	STPM01FTR		
W1 W3	Load				2-way screw terminal block 7.5 mm pitch	Through hole	Phoenix contact	1988105	RS code: 548-7301	
X1	16 MHz				16 MHz crystal	SMD	Any		RS code: 547-6531	
Y1	8 MHz				16 MHz crystal	SMD	Any		RS code: 671-9242	
k1	16 A 12 Vdc coil (Do not fit)		(Do not fit)		(Do not fit)	(Do not fit)	(Do not fit)	(Do not fit)	(Do not fit)	(Do not fit)
k2	16 A 12 Vdc coil		12 V/16 A		Low profile SPDT power relay	Through hole	OMRON	G2RL-1-E 12DC	RS code: 365-0535	

6 Schematics

Figure 9. Top page

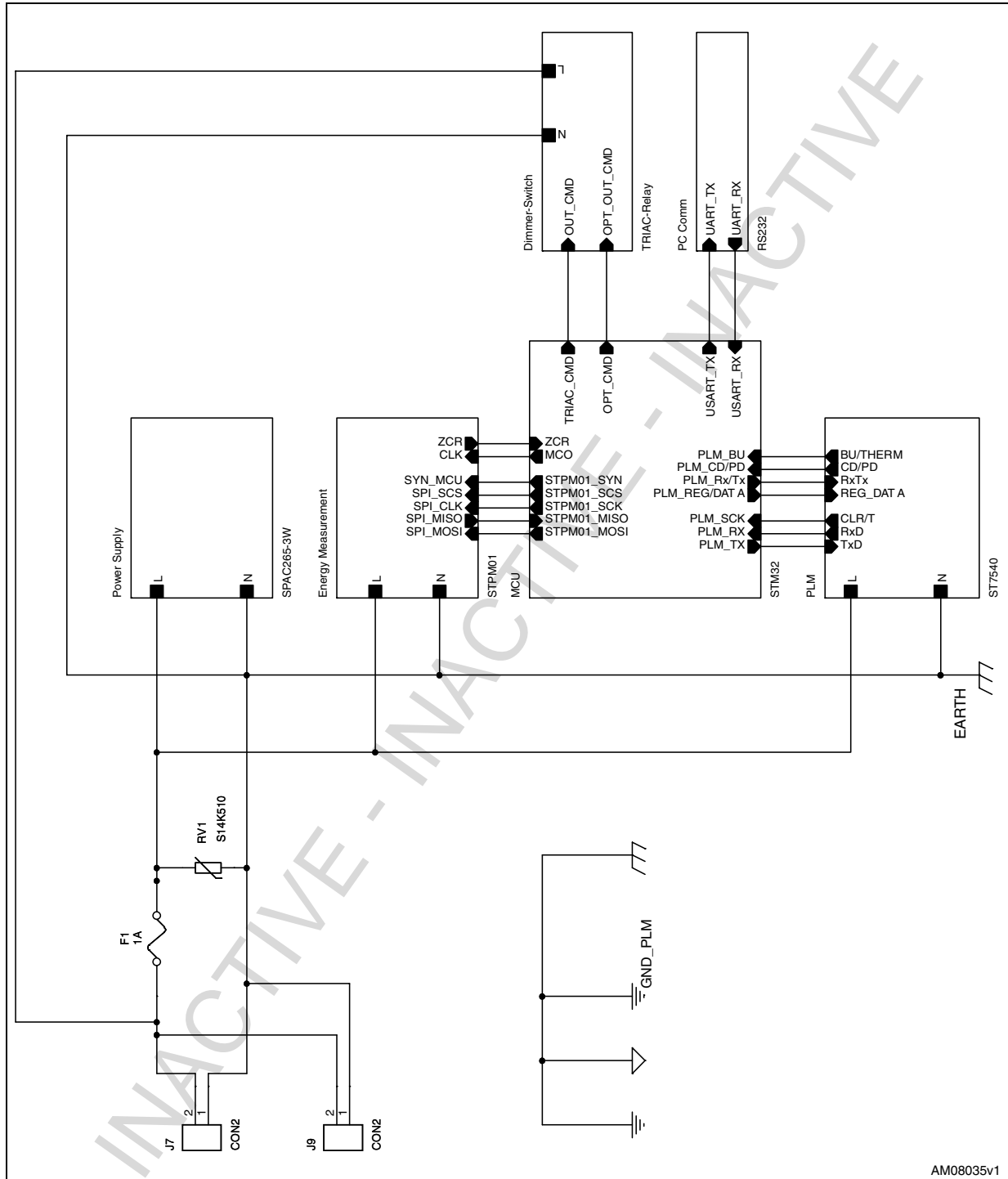

Figure 10. RS232 communication section

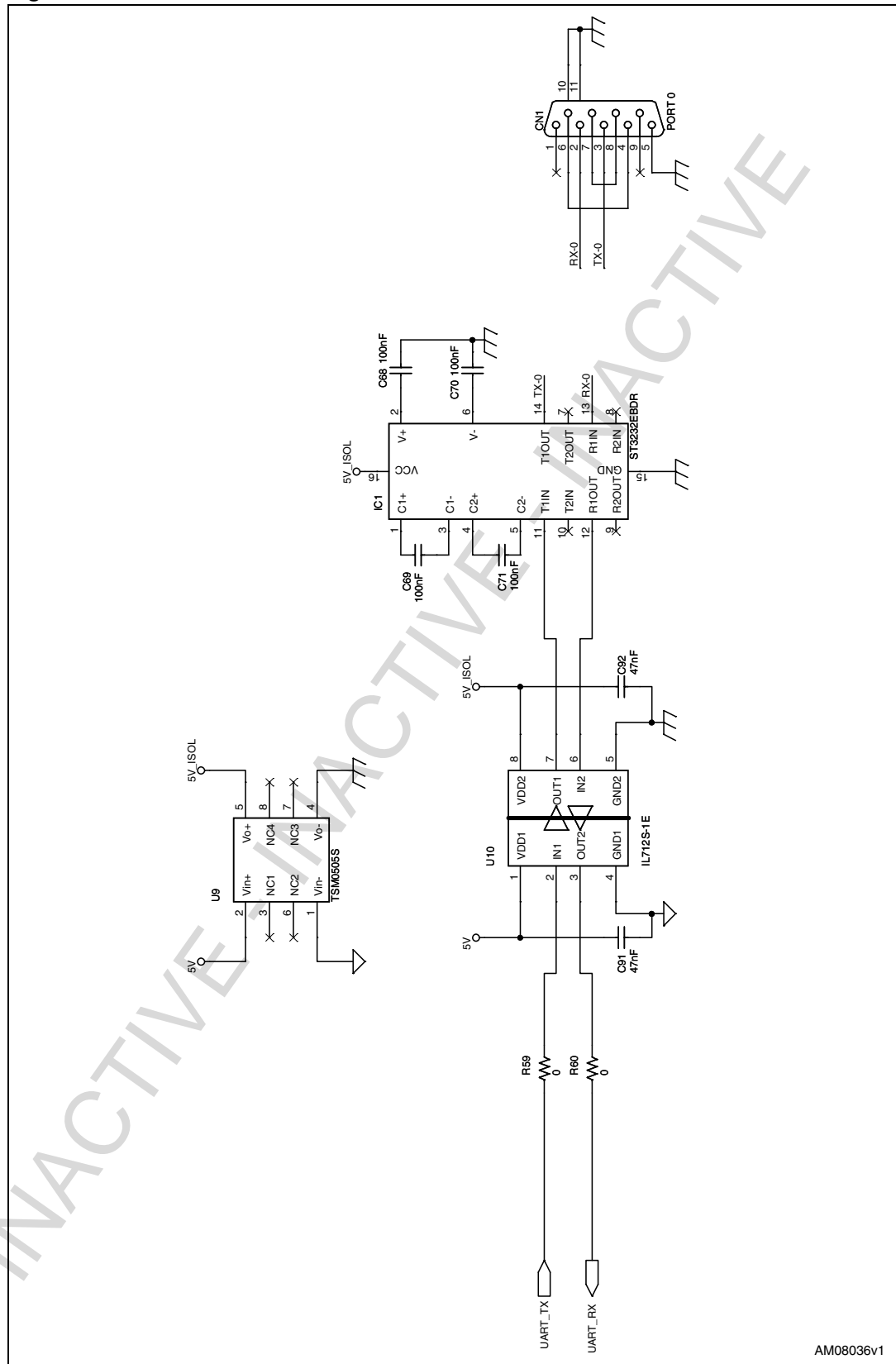
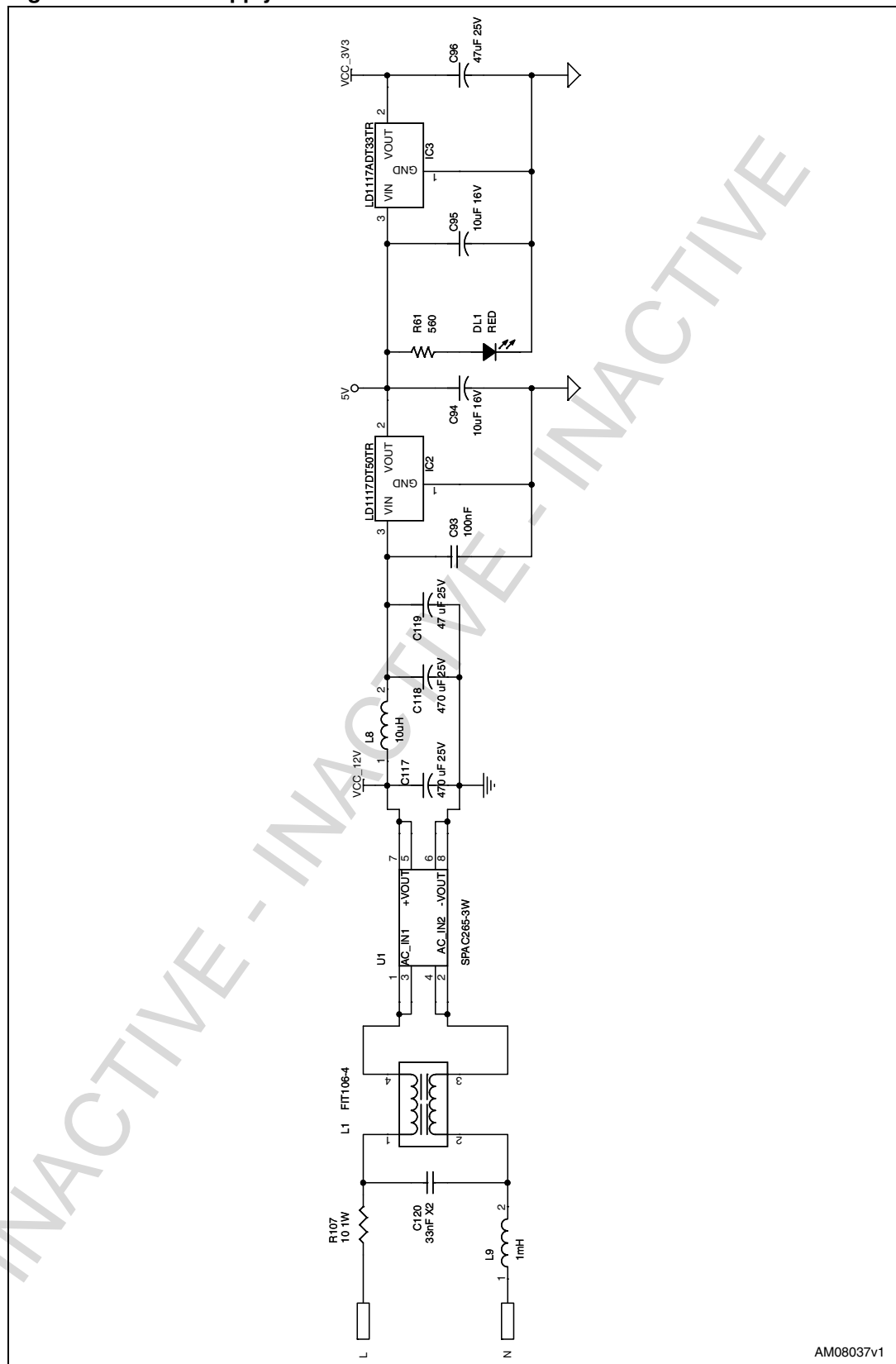
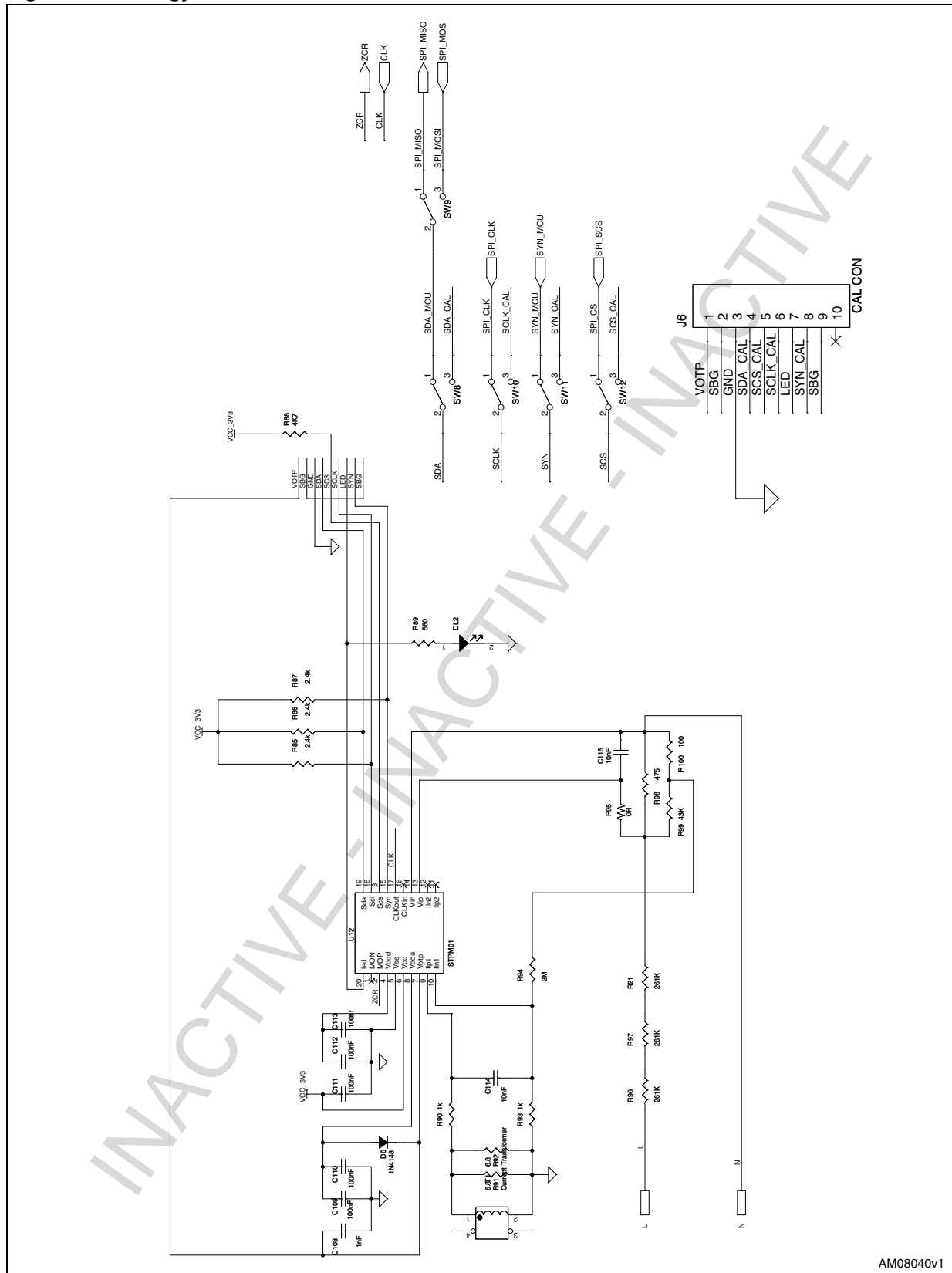

Figure 11. Power supply section



AM08037v1

Figure 14. Energy meter



AM08040v1

7 Revision history

Table 12. Document revision history

Date	Revision	Changes
13-Jan-2011	1	Initial release.

INACTIVE - INACTIVE - INACTIVE

Please Read Carefully:

Information in this document is provided solely in connection with ST products. STMicroelectronics NV and its subsidiaries ("ST") reserve the right to make changes, corrections, modifications or improvements, to this document, and the products and services described herein at any time, without notice.

All ST products are sold pursuant to ST's terms and conditions of sale.

Purchasers are solely responsible for the choice, selection and use of the ST products and services described herein, and ST assumes no liability whatsoever relating to the choice, selection or use of the ST products and services described herein.

No license, express or implied, by estoppel or otherwise, to any intellectual property rights is granted under this document. If any part of this document refers to any third party products or services it shall not be deemed a license grant by ST for the use of such third party products or services, or any intellectual property contained therein or considered as a warranty covering the use in any manner whatsoever of such third party products or services or any intellectual property contained therein.

UNLESS OTHERWISE SET FORTH IN ST'S TERMS AND CONDITIONS OF SALE ST DISCLAIMS ANY EXPRESS OR IMPLIED WARRANTY WITH RESPECT TO THE USE AND/OR SALE OF ST PRODUCTS INCLUDING WITHOUT LIMITATION IMPLIED WARRANTIES OF MERCHANTABILITY, FITNESS FOR A PARTICULAR PURPOSE (AND THEIR EQUIVALENTS UNDER THE LAWS OF ANY JURISDICTION), OR INFRINGEMENT OF ANY PATENT, COPYRIGHT OR OTHER INTELLECTUAL PROPERTY RIGHT.

UNLESS EXPRESSLY APPROVED IN WRITING BY AN AUTHORIZED ST REPRESENTATIVE, ST PRODUCTS ARE NOT RECOMMENDED, AUTHORIZED OR WARRANTED FOR USE IN MILITARY, AIR CRAFT, SPACE, LIFE SAVING, OR LIFE SUSTAINING APPLICATIONS, NOR IN PRODUCTS OR SYSTEMS WHERE FAILURE OR MALFUNCTION MAY RESULT IN PERSONAL INJURY, DEATH, OR SEVERE PROPERTY OR ENVIRONMENTAL DAMAGE. ST PRODUCTS WHICH ARE NOT SPECIFIED AS "AUTOMOTIVE GRADE" MAY ONLY BE USED IN AUTOMOTIVE APPLICATIONS AT USER'S OWN RISK.

Resale of ST products with provisions different from the statements and/or technical features set forth in this document shall immediately void any warranty granted by ST for the ST product or service described herein and shall not create or extend in any manner whatsoever, any liability of ST.

ST and the ST logo are trademarks or registered trademarks of ST in various countries.

Information in this document supersedes and replaces all information previously supplied.

The ST logo is a registered trademark of STMicroelectronics. All other names are the property of their respective owners.

© 2011 STMicroelectronics - All rights reserved

STMicroelectronics group of companies

Australia - Belgium - Brazil - Canada - China - Czech Republic - Finland - France - Germany - Hong Kong - India - Israel - Italy - Japan - Malaysia - Malta - Morocco - Philippines - Singapore - Spain - Sweden - Switzerland - United Kingdom - United States of America

www.st.com