

# DEO-SR2

## Proximity & Wiegand Card Reader with Remote Control



**User Manual**

# INTRODUCTION

The SR2 is a compact, weather resistant multi-function card reader that can be used as a standalone programmable access control card reader as well as a Wiegand output card reader providing proximity entry for up to 1000 users, (998 common users and 2 panic users) PIN access is also possible via the remote control unit for the Administrator and all user data can be transferred from one unit to another within 3 minutes (Maximum connection is 10 units)

It reads both EM & HID card or key fob. It uses Atmel micro controller to ensure maximum performance in any environment, and the low-power circuit makes its service life prolonged

The SR2's unique feature is simple in design, easy to operate/program, and high reliability

## Features

- Weather resistant to IP66
- Reads 125KHz EM & HID card or key fob
- One programmable relay operation
- Pulse mode, Latch mode relay operation
- Remote infrared programmer
- Master Add/Master Delete cards
- 1000 users (998 common users & 2 panic users)
- User data can be transferred from one unit to another
- Wiegand 26-37 bit input & output
- Card block enrolment
- Tri-colour LED status display
- Built in light dependent resistor (LDR) for anti tamper
- Buzzer for audible or silent mode
- Low temperature resistance(-40°C)

## Specifications:

<b>User Capacity</b> Card/key fob	<b>1000</b> EM card and HID card
<b>Operating Voltage</b> Idle Current	<b>12 ~ 24V AC/DC</b> <40mA
<b>Proximity Card Reader</b> Radio Technology Read Range	<b>EM&amp;HID</b> 125KHz Proximity Card 2-6cm
<b>Wiring Connections</b>	Relay Output, Exit Button
<b>Relay</b> Adjustable Relay Output Time Lock Output Load	<b>One (NO, NC, Common)</b> 1-99 Seconds (5 seconds default) 2 Amp Maximum
<b>Environment</b> Operating Temperature Operating Humidity	<b>Meets IP66</b> -40°C ~60°C 20%RH-98%RH
<b>Physical</b> Colour Dimensions Unit Weight Shipping Weight	<b>ABS Shell</b> Black H: 102 W: 48 D:20mm 150g 250g

# Package Contents

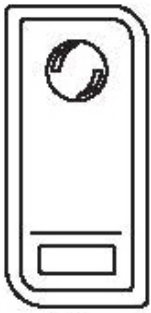

SR2 Card Reader

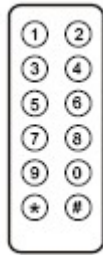

Infrared Remote Control

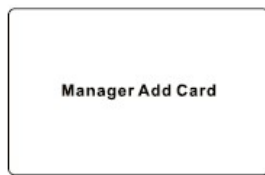
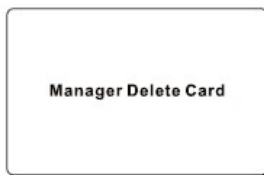

Manager Cards & 10 user cards or key fobs



Diode IN4004 (For relay circuit protection)



Self Tapping Screws: 3\*25mm



Wall Anchors



Screw Driver

# INSTALLATION

- Remove the back cover from the unit
- Drill 2 holes(A,C) on the wall for the screws and one hole for the cable
- Knock the supplied rubber bungs to the screw holes(A,C)
- Fix the back cover firmly on the wall with 4 flat head screws
- Thread the cable through the cable hole(B)
- Attach the unit to the back cover

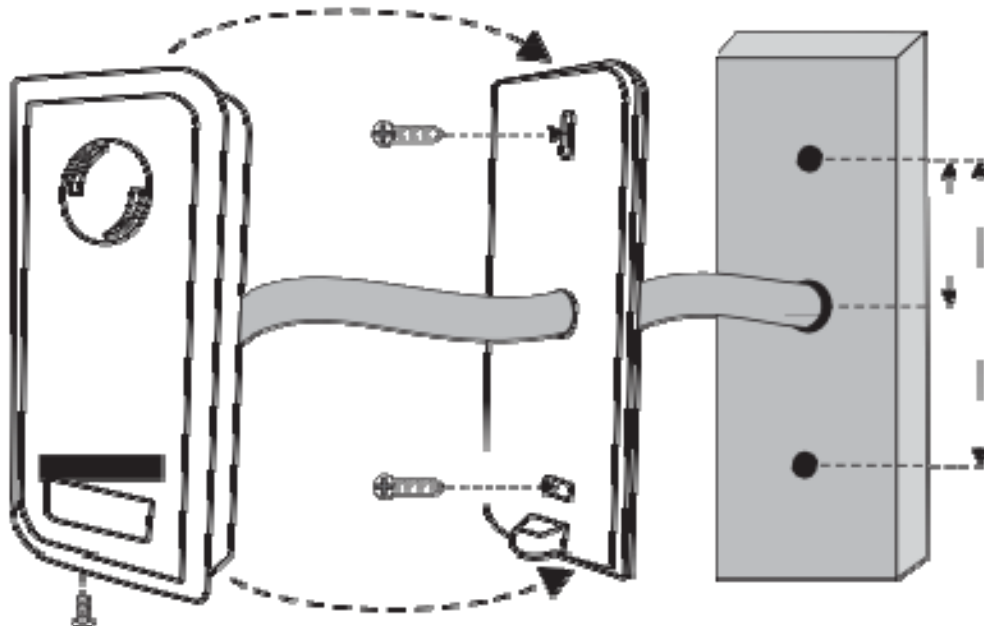

## Wiring cable

Wire Insulation Colour	Function	Notes
Red	Power + (AC1)	12-24 Volts AC/DC Power input
Black	GND	Ground
Pink	AC2	12-24 Volts AC power input
Blue	NO	Normally open relay output
Purple	COM	Common connection for relay output
Orange	NC	Normally closed relay output
Yellow	OPEN	Request to exit input (REX)
Green	Data 0	Wiegand output Data 0
White	Data 1	Wiegand output Data 1
Grey	Alarm output	Negative output for alarm
Brown	Contact input	Door/gate input (Normally closed)

# Connection Diagram Examples

## Common power supply for magnetic lock (Fail open – power to lock)

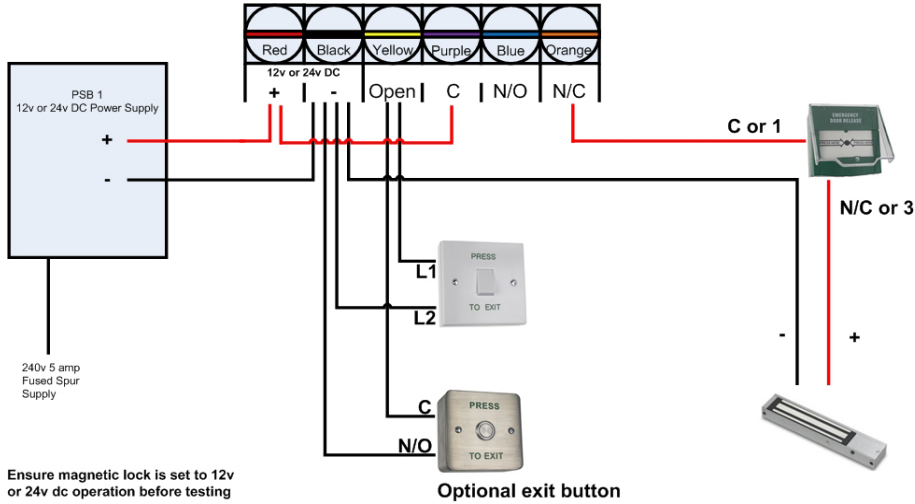

## Common power supply for lock release (Fail secure – power to unlock)

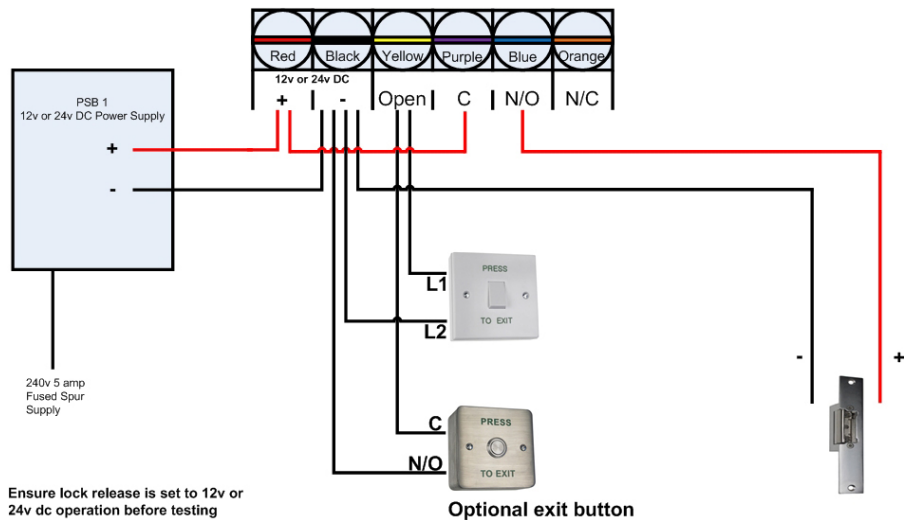

## Common power supply for auto gate controller (using Normally Open contact)

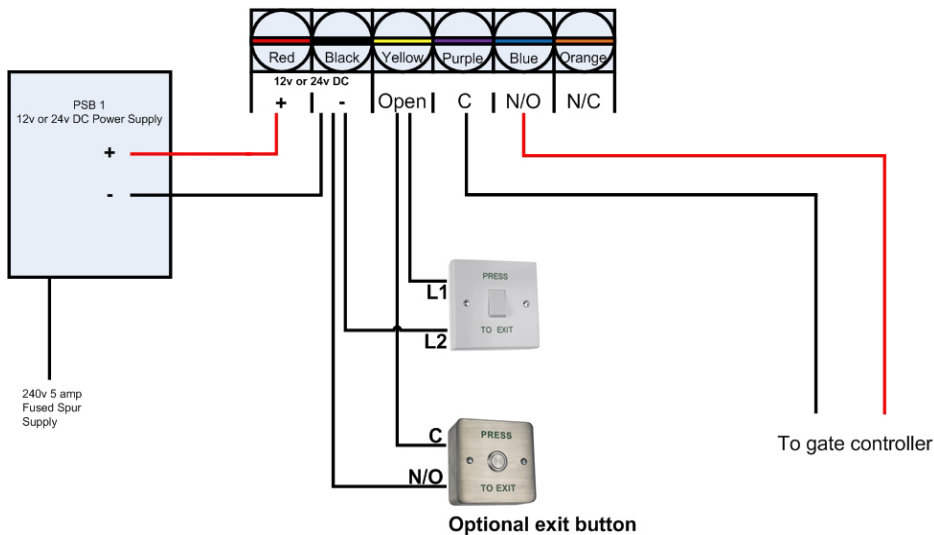

**Attention:** Install a 1N4004 or equivalent diode across the locking device when using a common power supply to prevent any back E.M.F as the reader might damage. (1N4004 is included in the packing)

## Connection to standard Wiegand controller or PC access control system

To enable the SR2 to operate as a Wiegand card reader, enter program mode \*123456#73#\*

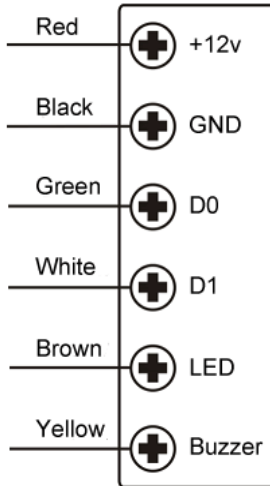
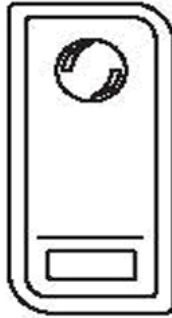

## Set Operation Mode – Stand-alone or Wiegand (Default is stand-alone)

Programming Step	Remote Control Operation
1. Enter Program Mode	* (Master Code) #
2. Stand-alone Operation	72 # is factory default for stand-alone
3. Wiegand Reader Operation	73 #
4. Exit Program Mode	*

## User data transfer connection (1 x power supply and 9 x SR2 units)

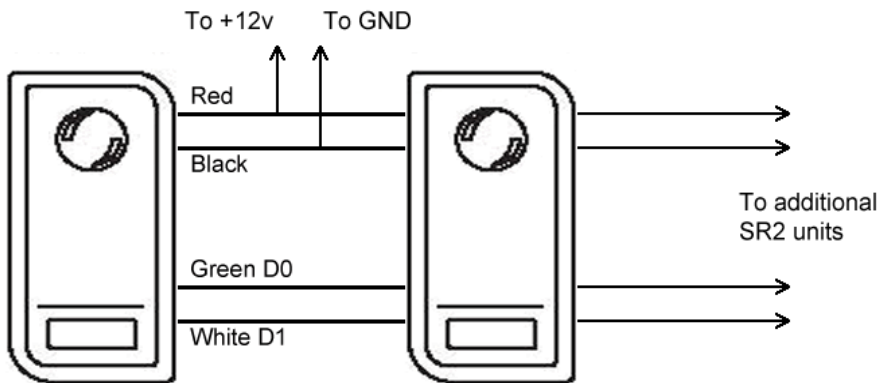

## Set User Data Transfer

Programming Step	Remote Control Operation
1. Enter Program Mode	* (Master Code) #
2. Set Transfer Data on the first SR2 For all 1000 users, this will take 3 minutes	96 # Within 3 minutes the green LED will shine, after 1 x bleep the LED will turn red to confirm data transfer
3. Exit Program Mode	*

# PROGRAMMING

Programming will vary depending on access configuration. Follow the instructions according to your access configuration

## General Programming Information – Two ways

- **Remote Control:** Please use the Infrared Remote Control to program the Reader. The infrared receiver head is near the LED, so when you program the reader, please direct the Remote Control to the LED
- **User ID number:** Assign a user ID to the access card in order to track it. The user ID number can be any number from 0-997. **IMPORTANT:** User IDs do not have to be preceded with any leading zeros  
Recording of User ID is crucial. Modifications to the user require the User ID to be available
- **Proximity Card:** Any 125KHz industry standard 26 bit EM and HID Proximity card or key fob

## Sound and Light indications

Operation Status	Led Colour	Buzzer
Stand by	Red light bright	-
Enter into programming mode	Red light shines	One bleep
In the programming mode	Orange light bright	One bleep
Operation error	-	Three beeps
Exit from the programming mode	Red light bright	One bleep
Open lock	Green light bright	One bleep
Alarm **	Red light Shines quickly	Bleeps

**\*\* Please see Reset Procedure for ALARM**

## Enter and Exit Program Mode Via the Remote Control

Programming Step	Remote Control Operation
1. Enter Program Mode	* <b>(Master Code) #</b> Factory default is 123456
2. Exit Program Mode	*

## Set New Master Code Via the Remote Control

Programming Step	Remote Control Operation
1. Enter Program Mode	* <b>(Master Code) #</b>
2. Enter New Master Code	<b>0 (New Master Code) # (Repeat New Master Code) #</b>
3. Exit Program Mode	*

## Set Operation Mode – Stand-alone or Wiegand (Default is stand-alone)

Programming Step	Remote Control Operation
1. Enter Program Mode	* <b>(Master Code) #</b>
2. Stand-alone Operation	<b>72 #</b> is factory default for stand-alone
3. Wiegand Reader Operation	<b>73 #</b>
4. Exit Program Mode	*

### Set User Data Transfer Via the Remote Control

Programming Step	Remote Control Operation
1. Enter Program Mode 2. Set Transfer Data on the first SR2 For all 1000 users, this will take 3 minutes	* <b>(Master Code) #</b> <b>96 #</b> Within 3 minutes the green LED will shine, after 1 x bleep the LED will turn red to confirm data transfer
3. Exit Program Mode	*

### Add User Cards Via the Remote Control

Programming Step	Remote Control Operation
1. Enter Program Mode	* <b>(Master Code) #</b>
2. <b>Add Card: Using Auto ID number</b> (Allows the SR2 to assign Card to next available User ID number)	<b>1 (Present Card) #</b> Repeat Step 2 for additional user cards
<b>OR</b> 3. Add Card: Select <b>Specific ID number</b> (Allows manager to define a specific User ID to associate the card to)	<b>1 (User ID) # (Present Card) #</b> The user ID is any number from 0-997
<b>OR</b> 4. Add Card: by <b>Card Number</b>	<b>1 (Input the 8/10 digit Card number) #</b>
<b>OR</b> 5. Add Card: <b>Block Enrolment</b> (Allows the master card to add up to 998 cards in a single step – this takes 2 minutes)	<b>1 (User ID) # (Card Quantity) # (The first card number) #</b> Card or fob number <b>MUST</b> be consecutive
6. Exit Program Mode	*

### Add PIN User – For Administrator for Remote Control

Programming Step	Remote Control Operation
1. Enter Program Mode	* <b>(Master Code) #</b>
2. Add PIN: <b>Via remote controller</b>	<b>1 (Enter PIN number, 4-6 digits) #</b>
3. Exit Program Mode	*

### Delete User Cards Via the Remote Control

Programming Step	Remote Control Operation
1. Enter Program Mode	* <b>(Master Code) #</b>
2. Delete Card: <b>By read card</b>	<b>2 (Present Card) #</b> Repeat Step 2 for additional user cards before pressing the #
<b>OR</b> 3. Delete Card: <b>Select Specific ID</b>	<b>2 (Enter user ID number) #</b> The user ID is any number from 1-998
<b>OR</b> 4. Delete Card: <b>by Card Number</b>	<b>2 (Input the 8/10 digits Card number) #</b>
3. Exit Program Mode	*



### Delete All Users Via the Remote Control

Programming Step	Remote Control Operation
1. Enter Program Mode	* <b>(Master Code) #</b>
2. Delete All User Cards	<b>2 (Master Code) #</b>
3. Exit Program Mode	*

### Set Relay Configuration Via the Remote Control

The relay configuration sets the behaviour of the output relay on activation

Programming Step	Remote Control Operation
1. Enter Program Mode	* <b>(Master Code) #</b>
2. Pulse Mode	<b>3 (1-99) #</b> The relay time is 1-99 seconds. (1 is 50mS.) Default is 5 seconds
<b>OR</b>	<b>3 0 #</b>
3. Latch Mode	Sets the relay to ON/OFF Latch mode
4. Exit Program Mode	*

### Set Strike-out Alarm Via the Remote Control

The strike-out alarm will engage after 10 failed card attempts. Default setting is OFF. The strike-out alarm can be set to deny access for 10 minutes after engaging or it can be set to disengage only after presenting a valid user card or Master code

Programming Step	Remote Control Operation
1. Enter Program Mode	* <b>(Master Code) #</b>
2. Strike-Out OFF	<b>6 0 #</b> (factory default)
<b>OR</b>	
3. Strike-Out ON	<b>6 1 #</b> Access will be denied for 10 minutes
<b>OR</b>	
4. Strike-Out ON (Alarm) Set alarm time	<b>6 2 #</b> <b>5 (0 - 30) #</b> factory default is 1 minute Enter Master code # or valid user card to silence
5. Exit Program Mode	*

### Set Audible and Visual Response Via the Remote Control

Programming Step	Remote Control Operation
1. Enter Program Mode	* <b>(Master Code) #</b>
2. Control LED	OFF = <b>70 #</b> ON = <b>71 #</b>
<b>OR</b>	
3. Control Sounds	OFF = <b>74 #</b> ON = <b>75 #</b> (Factory defaults are ON)
4. Exit Program Mode	*

## Set Card Reading Type Via the Remote Control

Programming Step	Remote Control Operation
1. Enter Program Mode	<b>* (Master Code) #</b>
2. Read EM & HID card	<b>93 #</b> (factory default)
<b>OR</b>	
3. Read EM card only	<b>94 #</b>
<b>OR</b>	
4. Read HID card only	<b>95 #</b>
5. Exit Program Mode	<b>*</b>

### Add cards by Master Add Card

Programming Step	Action
1. Present the <b>Master Add Card</b>	Present the user card/s to be added Present the <b>Master Add Card</b> to confirm

### Delete cards by Master Delete Card

Programming Step	Action
1. Present the <b>Master Delete Card</b>	Present the user card/s to be deleted Present the <b>Master Delete Card</b> to confirm

# Reset Procedure

### Reset Alarm:

The alarm will sound for 3 minutes. To reset, present a valid user card or enter **\* (Master Code) #** via the remote control

### Reset to Factory Default:

To reset to factory default, power off, press the Exit Button or short circuit the Black (GND) and Yellow (Open) wires, and then power on, there will be two bleeps, and the LED light will turn orange, keep this condition until you hear a long bleep after 10 seconds. The LED will turn red to confirm factory default is successful

### Reset to Factory Default to add new Mater Cards:

To reset to factory default, power off, press the Exit Button, or short circuit the Black (GND) and Yellow (Open) wires, and then power on, there will be two bleeps, and the LED light will turn orange

Release the exit button or the Black (GND) and Yellow (Open) wires, then present any two 125KHz EM cards or key fobs and the LED will turn red to confirm factory default is successful

The first card presented will be the **Master Add Card**, and the second card will be the **Master Delete Card**

**Note:** Reset to factory default, the user's card/key fob information is still retained

The SR2's alarm trigger is activated by an LDR (Light Dependant Resistor) which is located to the rear left side of the unit as illustrated below

The alarm function is designed as an 'Anti-Theft' facility which cannot be disabled but it can be stopped by presenting a valid card or key fob to the reader or entering the Master Code followed by the # sign via the remote

Alternatively, you can prevent the alarm from activating by covering the LDR with a non-light absorbent substance. Black paint or a small amount of 'Blu-Tack' will work perfectly fine



This is the LDR (Light Dependent Resistor). The LDR is the SR2's Alarm Trigger Sensor and activated by light