

LED DALI RM16 Relay module - User Manual



Item no.: LC-004-400

1. Product Description

The DALI RM16 relay module is a compact relay module to drive standard contactor via DALI. The relay output is bistable. This results in a very low power consumption (~2mA), the current switching state is maintained in case of bus failure. The supply of the module is directly via the DALI line.

2. Specifications

supply	via DALI- Bus
typ. current consumption	2.1 mA
input	DALI
number of used DALI addresses	1
relay output switch on/off voltage	250Vac/400Vac
maximum nominal load and current	2000VA / 8A
max. inrush current	160A
type of relay contact	1 Wechsler
switching operations at nominal load, resistive	3×10^4
maximum switching frequency	1Hz
connecting wire cross section	0,5-1,5 mm ²
Dimensions (L x W x H) in mm	59 x 33 x 15 mm
weight	29g

3. Description

1. Compact relay module for the direct control of 230V AC loads via DALI
2. Ballasts without DALI-input can be simply integrated in a DALI lighting control system. The loads can then be switched ON and OFF by DALI commands.
3. The DALI RM16 module fulfills the requirements for DALI Device Type 7 - switching function (firmware 2.0 and higher)
4. Free DALI-Cockpit software package for configuration of DALI-systems and DALI components

5. The DALI RM16 is supplied directly by the DALI signal line
6. RM16 type for high inrush currents up to 160A
7. The DALI RM16 module acts like any conventional DALI ballast. Hence it can be addressed and configured.

Addressing and Configuration

Addressing of the DALI RM 8/16 can be initiated by a DALI control device or a DALI configuration tool (only the random addressing mode is supported).

With the help of the DALI-Cockpit (Software) tool and a DALI USB interface (Interface module between DALI-line and PC via USB) the DALI RM16 can be addressed and configured.

DALI Functions and Instruction Set

The DALI RM16 acts as a DALI-controlled relay contact. Hence ballasts can be integrated in a DALI-system and switched on and off by DALI commands. The DALI RM16 acts like a standard DALI ballast for non-dimmable loads. It is based on the DALI specification for control gear (IEC 62386-102) and the device type 7 extension (IEC 62386-208).

Connection

The relay module is supplied directly by the DALI-line. It must NOT be connected to the mains. A typical value of current consumption is 2.1mA. In order to supply components on a DALI line the installation of a DALI power supply (DALI PS) is necessary. The connection to the DALI line is polarity free. The DALI input is protected against overvoltage up to 250VAC. For RM16 type internally the DALI-terminals are connected through as visualized on the housing (see connection plan).

The relay output of the RM16 type supports loads up to 2000VA and currents up to 8A. The RM16 modules are suitable for high inrush currents up to 160A.

4. Dimensions

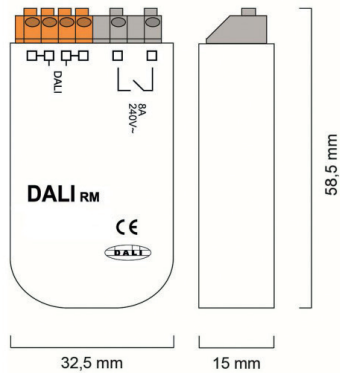

5. Wiring Diagram

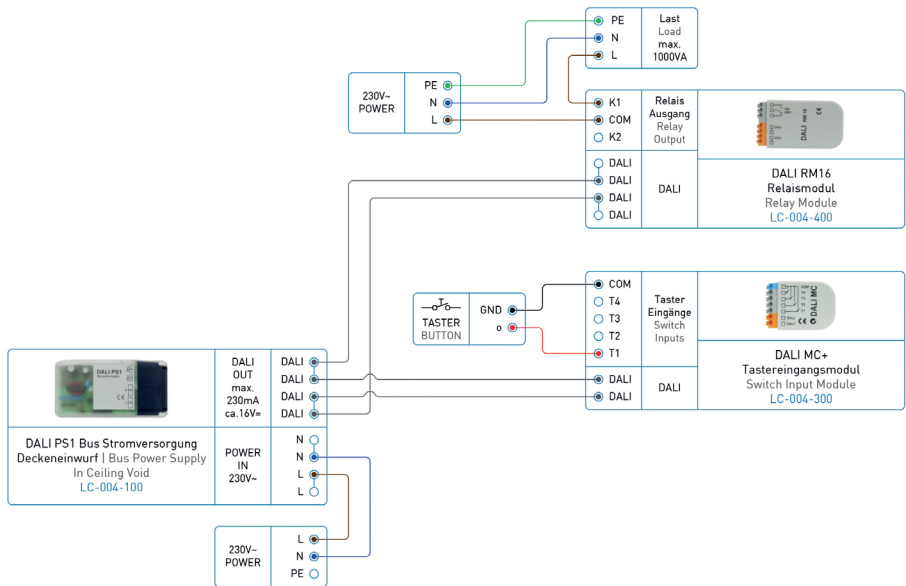

6. Safety Warnings

- 6.1. To avoid installed the product in minefield, strong magnetic field and high voltage area.
- 6.2. To ensure the wiring is correct and firm avoiding short circuit damages to components and cause fire.
- 6.3. Please install the product in a well ventilated area to ensure appropriate temperature environment.
- 6.4. The product must be worked with DC constant voltage power supply.
Please check the consistence of input power with the product, if the output voltage of the power comply with that of the product.
- 6.5. Connect the wire with the power on is forbidden. Ensure proper wiring first then check to ensure no short-circuit, then power on.
- 6.6. Don't repair it by yourself whenever an error occur. Contact the supplier for any inquiry.