

EZL-50 User's Manual

Revision B

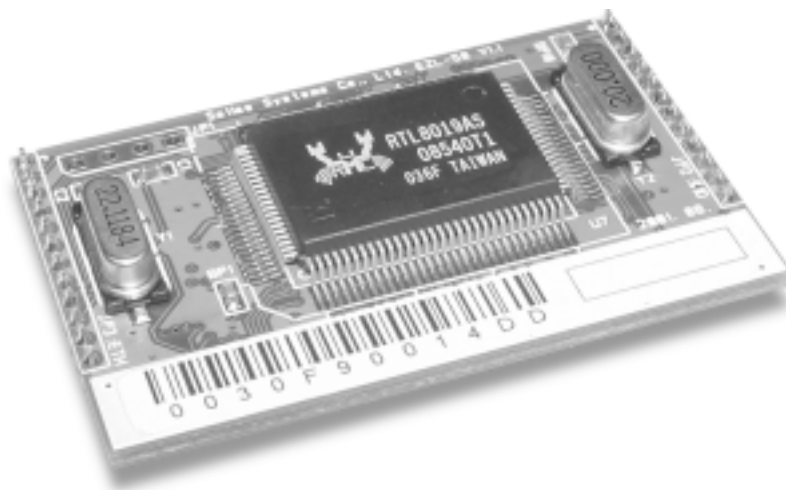

 **Sollae Systems**

Table of Contents

1. Overview	1
1.1. Components	1
1.2. Specifications	1
1.3. EZL-50 EVB	1
1.4. Installation	2
1.5. Feature Overview	2
2. Getting Started	3
2.1. Configuration	3
2.1.1. ezConfig	3
2.1.2. Basic Function Setup	5
2.2. Communication Test	7
3. Advanced Function of ezTCP	10
3.1. Serial Port Interface	10
3.1.1. T2S (TCP to Serial)	10
3.1.2. ATC (AT Command)	10
3.1.3. COD (Connect On Demand)	11
3.1.4. TCP Connection Time Out (TIME OUT)	11
3.2. AT Command Interface	13
3.2.1. Basic AT Command	13
3.2.2. Extended AT Command	13
3.2.3. AT COMMAND Escape Sequence	14
3.2.4. Examples of ATC Application	15
3.3. Environment Setup	17
3.3.1. Environment Setup in ATC mode	17
3.3.2. IP Address-related Item Setup through DHCP Server	18
3.3.3. IP Address-related Item under Environment with ADSL	18
3.4. ezTCP Environment Setup Item	19
3.4.1. Network related Setup Item	19
3.4.2. Serial Port Setup Item	19
3.4.3. Serial Port Interface related Item	20

3.4.4. Miscellaneous	20
3.4.5. STATUS LED State Variation	20
4. APPENDIX	22
4.1. EZL-50 Firmware Download	22
4.2. EZL-50 Board Dimension / PIN Assignment	24
4.3. EZL-50 Schematic Diagram	25

1. Overview

1.1. Components

- EZL-50 Main body
- EZP-50 EVB (Optional)
- RS232 Cable (provided with EVB)
- DC 5V SMPS Power Adaptor (provided with EVB)

1.2. Specifications

- Processor : TS87C54X2 / TS87C51U2
- Memory : ROM 64K / RAM 32K
- Interface : 12Pin SIP X 2 (2mm pitch)
- Protocols : TCP/UDP/IP/ICMP, ARP, PPPoE, DHCP
- Power : DC 5V \pm 10%

1.3. EZL-50 EVB

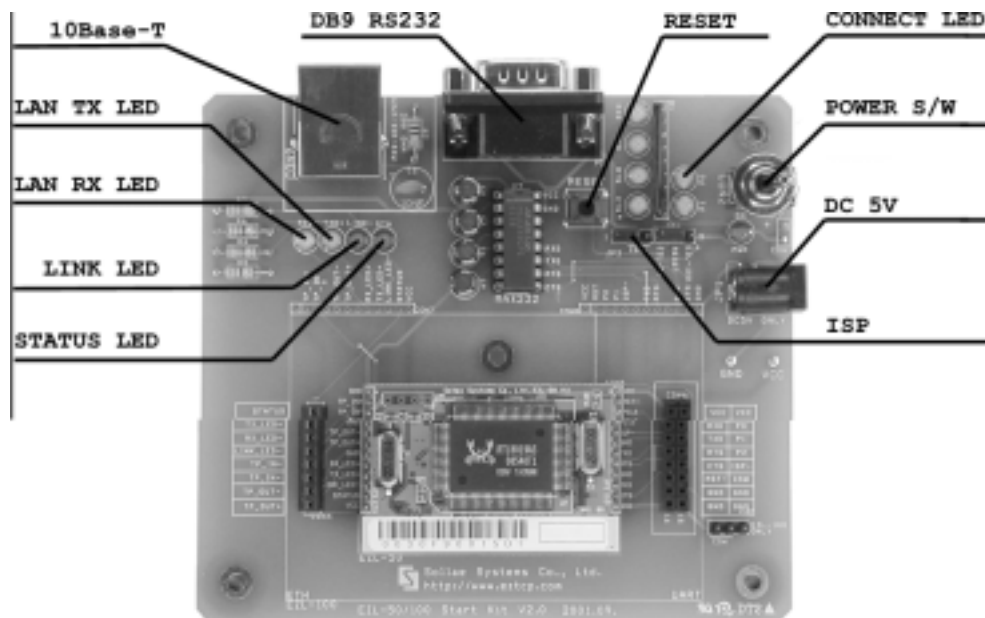

1.4. Installation

- After the power is turned on, check that the STATUS LED is blinking regularly. If LED is not turned on, check if EZL-50 is inserted into EVB correctly.
- After checking LED, connect RS232 cable and 10Base-T cable to each port of the main body separately, and then EZL-50 is now available.

1.5. Feature Overview

EZL-50 (hereafter ezTCP) is a serial port to TCP/IP converter, in which one serial port and one Ethernet port (10Base-T) are installed. The serial port should be connected to a serial port of the control unit (hereafter DTE) and the Ethernet port should be connected to a switching hub (or dummy) compatible with the 10Base-T standard. The following figure outlined a serial to Ethernet conversion system configured with ezTCP:

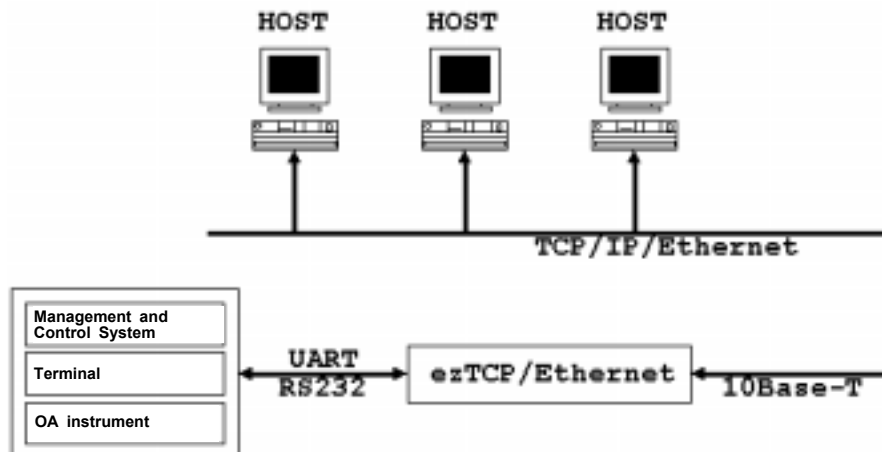

If a host computer (hereafter a host) is connected to the TCP port of ezTCP over an Ethernet network, the serial port of the DTE is connected virtually to the TCP port of the host. Then, ezTCP will function as an intermediate device between the serial port and the TCP port.

2. Getting Started

2.1. Configuration

This section describes how to configure and test T2S mode, which is the most convenient mode among the serial port interfaces of ezTCP. For more information about the other modes, see the following sections.

2.1.1. ezConfig

ezConfig, an integrated management application for Windows, allows you to change the basic environment information of EZL-50. ezConfig can run on Microsoft Windows platform but may not operate on some of the existing operating systems. The screen below shows the initial screen of ezConfig:



Each button on ezConfig functions as follows:

PROBE This button is used to search for all of the network-attached ezTCPs. The search results will be displayed on the MAC ADDRESS LIST box and you can select an item using a mouse or cursor as required. The value displayed on the box indicates the MAC ADDRESS of each ezTCP. The selected setup value of ezTCP will be displayed on the right side.

READ You can see only the ezTCP configuration details if you press this button after entering the 6-digit hexadecimal number printed on the ezTCP main body in the MAC ADDRESS box. It is useful when there are too many ezTCPs attached to the network to search for one from the LIST box.

WRITE This button is used to save the changed value in ezTCP after modifying the configuration. Make sure not to press this button during operating ezTCP since ezTCP will automatically be reset right after its environment setup value is saved. Otherwise, it may cause malfunction.

EXIT This button is used to close ezConfig. You can also close it by pressing ESC key on the keyboard.

CHANGE PWD ezTCP provides User Authentication function to prevent an unwanted person from modifying the configuration. The authentication process is performed through the password string verification. When entering or changing the password strings, you can use this button. Changing the ezTCP configuration details if a password has been entered requires the proper password to be entered in the PASSWORD field.

STATUS This button is used to read a dynamic variable value during operating ezTCP. Pressing this button will display a new window, where the time-lapse after the power is on, the current IP address, and the data throughput of the serial port are indicated. Double-clicking each item on the MAC ADDRESS LIST will carry out the same function.

ezConfig can be used to change the IP address related items, the serial port setup value, the serial port operation mode, and how to setup ezTCP. This section describes these functions briefly. For more information, see the following sections. The items you should setup when using T2S mode of ezTCP are listed as follows:

LOCAL IP ADDRESS	ezTCP IP Address
SUBNET MASK	Network Subnet Mask
GATEWAY	Primary Network Gateway
BAUD RATE	Serial Port Baud Rate
DATA BITS	The Number of Serial Port Data Bit
PARITY	Serial Port Data Parity
FLOW CTRL	Whether to use the Hardware Transfer Control on the Serial Port
MUX TYPE	ezTCP Serial Interface Type
TIMEOUT	Connection Time Out
LOCAL PORT	TCP Port Number for Connection Standby

* EZL-50 has 8 bit of fixed data bits and do not supports PARITY.

2.1.2. Basic Function Setup

The following example shows how to read and change ezTCP's basic functions. Try changing ezTCP setup value according to the following sequence:

- When the ezTCP power is turned on and the LAN cable is connected correctly, pressing [PROBE] or [READ] button will display the following window:

```
ezConfig
Reading ezTCP's environment variables.....
MAC address 00:30:f9:00:00:01
```

- If a network-attached ezTCP is detected, the following message will be displayed. If a message pops up indicating that there is no response from ezTCP, check that the power is turned on and the cable is connected correctly, then try pressing [PROBE] or [READ] button.

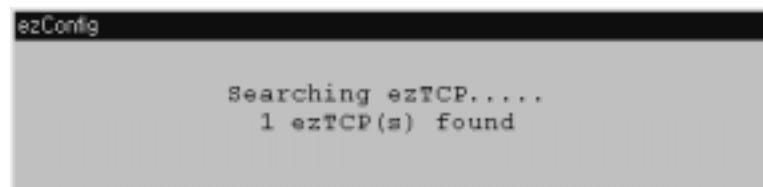

- If more than one ezTCP is detected, ezTCP's MAC ADDRESS will be displayed in the [MAC ADDRESS LIST] box on ezConfig. Check if the MAC ADDRESS displayed in the [MAC ADDRESS LIST] window corresponds to that printed on ezTCP main body. The following screen shows this process:

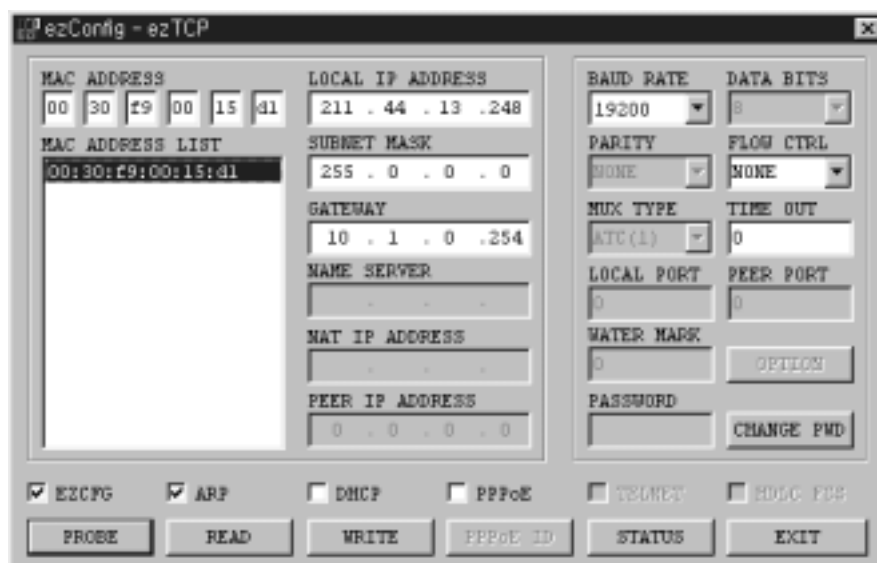

- On ezConfig, set [LOCAL IP ADDRESS], [LOCAL PORT], and the serial port setting to be consistent with the test environment. After completing the setup, press [WRITE] button to save the changed values in ezTCP. If an error message appears during storing the setting, check if ezTCP is connected correctly, and then try again.

- In Windows' MS-DOS prompt window, check the IP address is set correctly by giving the PING command. If the ezTCP IP address is set correctly, the PING results will be displayed as follows. If a message, "Request timed out", is displayed, check that IP address setup value again.

```
C:\>ping a.b.c.d
```

```
Pinging a.b.c.d with 32 bytes of data:
```

```
Reply from a.b.c.d: bytes=32 time=1ms TTL=64
```

```
Reply from a.b.c.d: bytes=32 time=1ms TTL=64
```

```
Reply from a.b.c.d: bytes=32 time=1ms TTL=64
```

```
Reply from a.b.c.d: bytes=32 time=1ms TTL=64
```

2.2. Communication Test

You can conduct a simple test using Hyper Terminal or telnet terminal for Windows if the IP-related items of ezTCP are set correctly through ezConfig. A communication test will be conducted as follows:

- Connect the serial cable to the serial ports of both ezTCP and PC respectively.
- Run Hyper Terminal, change the serial port baud rate, data bit, parity bit and flow control, and then save the changed values. Each setup value must correspond to those configured by ezConfig.
- In Windows' MS-DOS prompt window, run telnet terminal according to the following process. Note that a.b.c.d is the ezTCP IP address and xxxx is the value of ezTCP's [LOCAL PORT]:

```
C:\>telnet a.b.c.d xxxx
```

- If telnet terminal is successfully connected, RUN LED of ezTCP will stop blinking and shift to a constant lightened state. If RUN LED is blinking regularly after running telnet terminal, check ezTCP setup value again.
- If the telnet terminal connection is successfully established, Hyper Terminal and telnet terminal will be connected to each other through ezTCP as shown in the following picture:

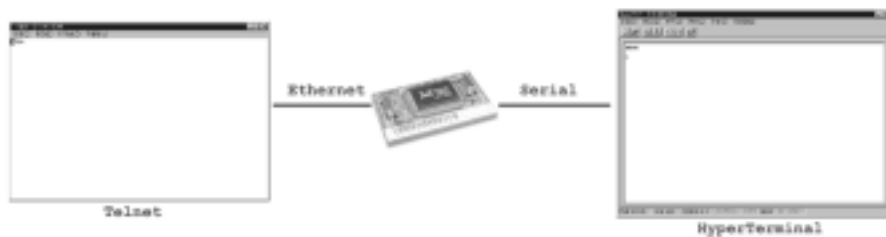

- When the two ends are connected to each other, a character input from telnet terminal will be output to Hyper Terminal, and vice versa.
- When "abcd" is input on telnet terminal, the output result is shown as follows:



- When "1234" is input from Hyper Terminal, the output result is

shown on telnet terminal as follows:

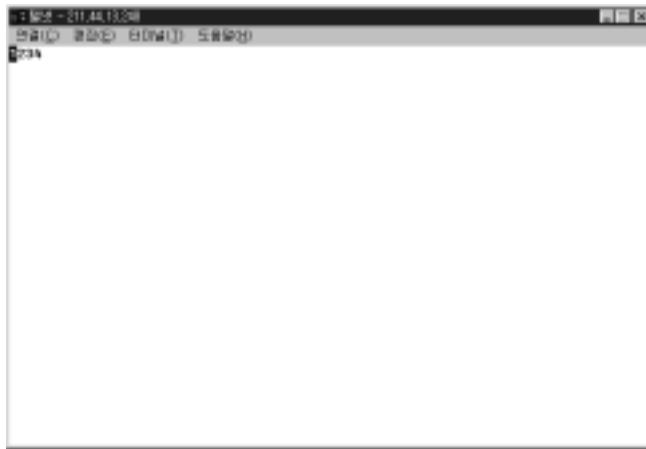

- If the text appears garbled, check if items related to the serial port of ezTCP correspond to the serial port setup value of Hyper Terminal.
- If nothing is input on the keyboard for specified period of time when the [TIME OUT] value of ezConfig is set bigger than 0, telnet terminal will terminate the connection while displaying a connection termination message.

3. Advanced Function of ezTCP

3.1. Serial Port Interface

ezTCP supports three types of the serial communication interface mode: T2S, ATC, and COD. In T2S and COD modes, you can use ezTCP by simply connecting the serial port without modifying existing equipments' software. While in ATC mode, the existing equipments' software needs modifying. For ATC mode, the AT emulation function is supported and it allows you to use ezTCP for a standard modem. Those who have experienced with modem operation will take advantage of the full ezTCP functions without effort. You cannot change the interface mode through ezConfig; however, you can select a certain mode by downloading and upgrading the firmware, if required. The typical functions of each mode are listed below. The note at the end of each paragraph describes the items you should change through ezConfig when using the relevant mode.

3.1.1. T2S (TCP to Serial)

In this mode, ezTCP always wait for a connection request from an external device without voluntarily connecting itself to an external server or PC. In case an external host is connected to the specified port of ezTCP, ezTCP will connect the serial port to the TCP port. That is, it transmits data from the serial port to the TCP port and data from the TCP port to the serial port. This mode allows you to use ezTCP without modifying the existing equipment's software while using COD mode. In T2S mode, care should be taken that all data from the DTE to the serial port will be ignored until a connection from a certain external PC to ezTCP is established.

* Setup Fields: [TIME OUT], [LOCAL PORT]

3.1.2. ATC (AT Command)

You can use ezTCP for a standard modem. The extended commands supported by ezTCP allow you to designate the IP address and the port number of a host on the Internet and connect it through

ATD (T) command. After designating the connection standby port, using ATA command will also connect a host to ezTCP. For more information, see the following sections.

* Setup Fields: [TIME OUT]

3.1.3. COD (Connect On Demand)

COD mode allows ezTCP to voluntarily connect with the TCP port on an external PC or a server. When a DTE transmits data to the serial port, ezTCP will attempt connecting with a certain TCP port on the specified computer that already has IP address. If the connection is successful, this mode will transmit data already received from the serial port to the TCP port, and then exchange data between the TCP port and the serial port like the T2S mode. In COD mode, a TCP connection will begin when the size of data received from the serial port exceeds the pre-specified size (water mark), and the size is changeable (factory-set value is 1 byte). If the setup value is 0, a connection will begin right after the power is turned on.

* Setup Fields: [TIMEOUT], [WATER MARK], [PEER PORT], [PEER IP ADDRESS]

3.1.4. TCP Connection Time Out (TIME OUT)

ezTCP will terminate the connection if there is no data exchange for a specified period of time. The time period can be selected from 1 to 600 seconds, and the Time Out function is cleared if the time period is set to 0 second. If the Time Out is set to 10 seconds, the connection will be terminated after ten seconds when transmitting the last data. If the Time Out function is cleared, some problem may occur because the TCP connection status of ezTCP will remain unterminated when a host connected to ezTCP is shut down abnormally. If the Time Out is set to 0, the Keep-alive function on the TCP will be activated while the Time Out function is cleared. The Keep-alive transmits the

keep-alive packets and waits for their responses if there is no data exchange for a specified period of time. If no responses to the keep-alive packets are received consecutively for five times, it will forcibly terminate the current TCP connection. You do not need to pay attention to this operation since it is the internal TCP module function. The keep-alive function is optional for the TCP/IP protocol specification. On some operating systems, this function may not be available. If you want to terminate the connection from ezTCP in COD mode, it is recommended to use the Time Out function.

3.2. AT Command Interface

In ATC mode, using the standard AT command and the ten extended AT commands enables you to access the Internet. If the connection is successful CONNECT message is displayed and if the connection is failed or terminated NO CARRIER message is displayed, which is similar to a standard modem. The modem commands supported by ezTCP are listed below:

3.2.1. Basic AT Command

Command	Function	Note
A	passive connection	Connection Standby (Host >> ezTCP connection)
D	active connection	ezTCP >> Host connection
E	echo	Whether to echo the input character (E0-N, E1-Y)
H	off-hook	Forcible Disconnection
I	Inquiry	ezTCP related information output
O	Online	Online Command state >> Online
V	enable result code	Result Code Form (Number-V0, Character-V1)
Z	reset	ezTCP Initialization

3.2.2. Extended AT Command

ezTCP provides the unique extended command for the control of the Internet-related setup values, which are not supported by a standard modem. The extended AT commands start with 'AT+P' and are followed by the equal sign, '=', for setting up values. The question mark, '?', should be added to the end of the command when outputting the setup value. For example, enter the command when changing or checking ezTCP's IP address as follows:

AT+PLIP=a.b.c.d	>>
<< OK	
AT+PLIP?	>>
<< a.b.c.d	

The extended commands available on ATC mode are listed below:

Command	Function	Note
+PLIP	local IP address	
+PSM	subnet mask	
+PGIP	default router	
+PLP	listening TCP port	
+PTO	timeout	
+PRIP	Remote machine IP address	
+PRP	Remote machine TCP port	
+PWP	Write configuration	Store setting

* Setup Value ON/OFF Command: PRC (EZCFG), PARP (ARP), PDC (DHCP), PPE (PPPoE), and PRL (TELNET)

* The ON/OFF commands are set to ON (1) or OFF (0).

3.2.3. AT COMMAND Escape Sequence

When forcibly terminating the TCP connection of ezTCP, you should shift the online state to the online command state through '+++' escape sequence. Under the online command state, entering ATH will terminate the TCP connection and entering ATO will restore it to the online state. The guard times are required before and after the '+++' character transmission as follows:

Until inputting 1st '+' after the last transmit	More than 500 ms
'+' input interval	0~500 milliseconds
The delayed time after inputting the last '+'	More than 500 ms

* Note: The figures above require the guard time be set to 500 milliseconds.

3.2.4. Examples of ATC Application

- Telnet server connection (client mode):

AT+PRIP=aa.bb.cc.dd	: Telnet Server IP Address	>>
AT+PRP=23	: Telnet Port Number	>>
ATDT		>>
<< CONNECT		
<< Data transmission/reception		>>

* In case the telnet server terminates the connection:

<< NO CARRIER		
----------------------------	--	--

* In case the DTE terminates the connection:

<guard time> '+++> <guard time>		>>
<< OK		
ATH	: Connection Termination	>>
<< OK		

- TCP port no. 6000 connection:

AT+PRIP=aa.bb.cc.dd	: Server IP Address	>>
AT+PRP=6000	: Server TCP Port Number	>>
ATDT		>>
<< CONNECT		
<< Data Transmission/Reception		>>

- Server Mode:

AT+PLP=6000	: Listening TCP Port Number	>>
<< OK		

TA		>>
Wait until remote host connect to ezTCP		
<< CONNECT	: Connection Notifier	
<< Data Transmission/Reception		>>
<< NO CARRIER	: Connection Terminated	

- Examples of using Multiple Commands:

Like a standard modem, ezTCP supports simultaneous multiple commands input. Forbidding the echo command, outputting the return value as the number instead of the string, and connecting to the TCP port no. 6000 are exemplified as follows:

ATE	: Echo Forbidden	>>
<< OK		
ATV+PRIP=aa.bb.cc.dd+PRP=6000DT	: Echo Forbidden	>>
<< 1		
<< Data Transmission/Reception		>>

3.3. Environment Setup

Environment variables such as the IP address, the serial port rate, and the connection port number can be changed through AT command or ezConfig.

3.3.1. Environment Setup in ATC mode

After changing the environment setup value, you must use the +PWP command. +PWP is used to store the changed value in the actual EEPROM. If the ezTCP power is turned on or EEPROM configuration is changed by +PWP command, NO CARRIER message is displayed. The examples listed below are for setting each item:

AT+PLIP=aa.bb.cc.dd	: ezTCP's IP Address	▶
◀ OK		
AT+PGIP=bb.cc.dd.ee	: Gateway IP Address	▶
◀ OK		
AT+PSM=255.255.255.0	: Subnet Mask	▶
◀ OK		
AT+PLP=1470	: ezTCP's Listening TCP Port	▶
◀ OK		
AT+PTO=10	: Reception Time Out	▶
◀ OK		
AT+PWP	: Store the Setup Values	▶
◀ OK		
◀ NO CARRIER		

3.3.2. IP Address-related Item Setup through DHCP Server

Under environment with a network operating a DHCP server, DHCP protocol allows you to automatically set the IP address, subnet mask, gateway, and name server of ezTCP. Using DHCP automatic setup function requires you to check [DHCP] item on ezConfig. Note that you may have to check [ARP] item according to the type of DHCP servers.

3.3.3. IP Address-related Item Setup under Environment with ADSL

The data transmission/reception and IP allocation over ADSL are typically based on PPPoE protocol, which is embedded in ezTCP. PPPoE mode is activated by checking [PPPoE] item on ezConfig. If the ADSL modem independently supports the PPPoE communication function or an IP sharer is used, you should use this function through a fixed IP or DHCP without checking [PPPoE].

3.4. ezTCP Environment Setup Item

3.4.1. Network related Setup Item

Setup Item	Description
EZCFG*	Enable the remote setup by using ezConfig (Y/N)
ARP**	Enable IP Modification by using ARP (Y/N)
DHCP	Enable DHCP auto-configuration (Y/N)
PPPOE	Enable PPPoE (Y/N)
USERNAME	ADSL (PPPoE) User ID
PASSWORD	ADSL (PPPoE) User Password
LOCAL IP	ezTCP's IP Address
SUBNET MASK	IP Network Subnet Mask
GATEWAY	Primary Network Gateway

* If you set EZCFG item to NO, searching for ezTCP or changing the setup value through ezConfig will not be available.

** You may have to set ARP item to "YES" depending on the types of DHCP server when using DHCP function.

3.4.2. Serial Port Setup Item

Setup Item	Description
BAUD RATE	Serial Port Rate (1200 ~ 115200)
PARITY	Parity Bit: 0(no parity), 1(even), 2(odd)
DATA BITS	Data Bit: 7 ~ 8
RTSCTS*	Using Hardware Flow Control (Y/N)

* Changing DATA BITS, STOP bit, PARITY is not available.

* XON/OFF Flow Control is not supported.

3.4.3. Serial Port Interface related Item

Setup Item	Description
TIME OUT	Connection Time Out
MUX TYPE	T2S (0), ATC (1), COD (2)
LOCAL PORT	Listening TCP Port Number in T2S Mode
WATER MARK	If the amount of data specified in watermark is received from the serial port in COD mode, ezTCP attempt connecting to the host.
PEER IP	IP address, to which ezTCP will attempt TCP access, when using COD mode
PEER PORT	TCP port, to which ezTCP will attempt connecting, when using COD mode.

3.4.4. Miscellaneous

Setup Item	Description
TELNET	Connecting to ezTCP through telnet (Y/N)
PASSWORD*	Password String for changing ezConfig configuration

* Note: You can enter password up to 8 characters in English language. If you forgot the password, you can modify or delete the password by turning the power on or pressing the Reset button when the ISP jumper is connected.

3.4.5. STATUS LED State Variation

- **Fixed IP:** Blinking 1 time per 1 second
- **DHCP:** Blinking 4 times briefly until the IP address is assigned. Blinking 1 time per 1 second after the IP address is assigned.
- **PPPoE:** Blinking 4 times briefly in the normal state, 1 time per 1 second when the IP address is successfully assigned after attempting a connection in ATC/COD mode, 4 times briefly after returning the IP address when the connection is terminated.
- If a TCP connection is successfully established irrespective of the IP allocation scheme, [STATUS LED] is turned on. If the TCP connection is terminated, LED will start blinking again.

4. APPENDIX

4.1. EZL-50 Firmware Download

EZL-50 provides a firmware download function based on TFTP under environment with Ethernet. You can download the firmware through Sollae Systems HotFlash or a standard TFTP client provided by typical operating systems. The EZL-50 firmware upgrading process through HotFlash can be outlined as follows:

- Connect the ISP (JP3) jumper of EZL-50 EVB (LOW input) and turn the power on. Then, STATUS LED starts blinking rapidly and the firmware download mode is activated.
- On ezConfig, read the setup value of EZL-50 to check the IP address settings. Enter the proper IP address and press [WRITE] button to change the IP address, if required. The screen below shows the IP address, which is set to 211.44.13.248:

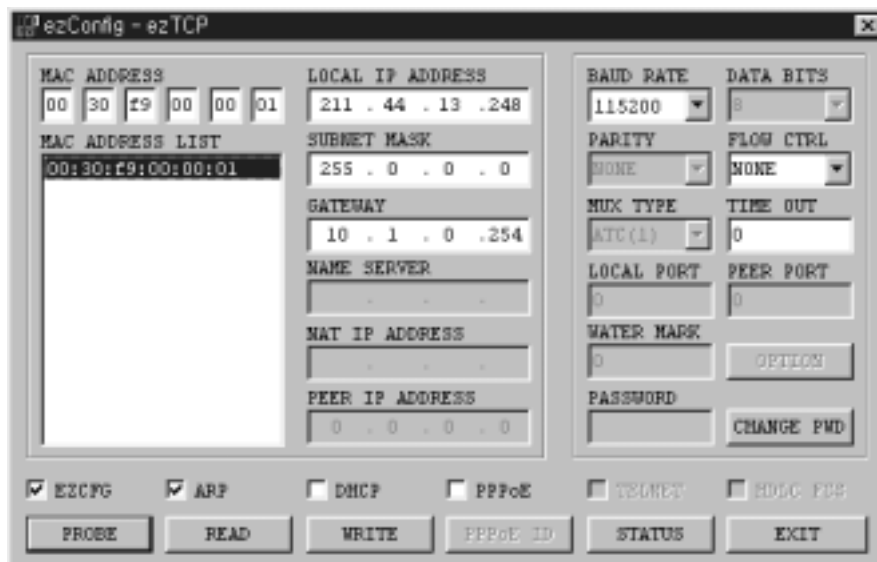

- Run HotFlash to enter IP address in the IP address window according to ezConfig. The following picture shows the IP address, which is set to 211.44.13.248:



- Press [FILE] button to read the firmware to upgrade. You can download the firmware from Sollae Systems web site.



- After reading the firmware, press [SEND] button to start downloading it. To stop downloading the firmware, press [STOP] button. The following picture shows the EZL-50 firmware downloading through HotFlash.



- If downloading is successful, [STATUS LED] of EZL-50 EVB starts blinking slowly. If CRC checking of the firmware detects an error after downloading, [STATUS LED] of EZL-50 EVB starts blinking rapidly while EZL-50 continues operating in downloading mode.

4.2. EZL-50 Board Dimension / PIN Assignment

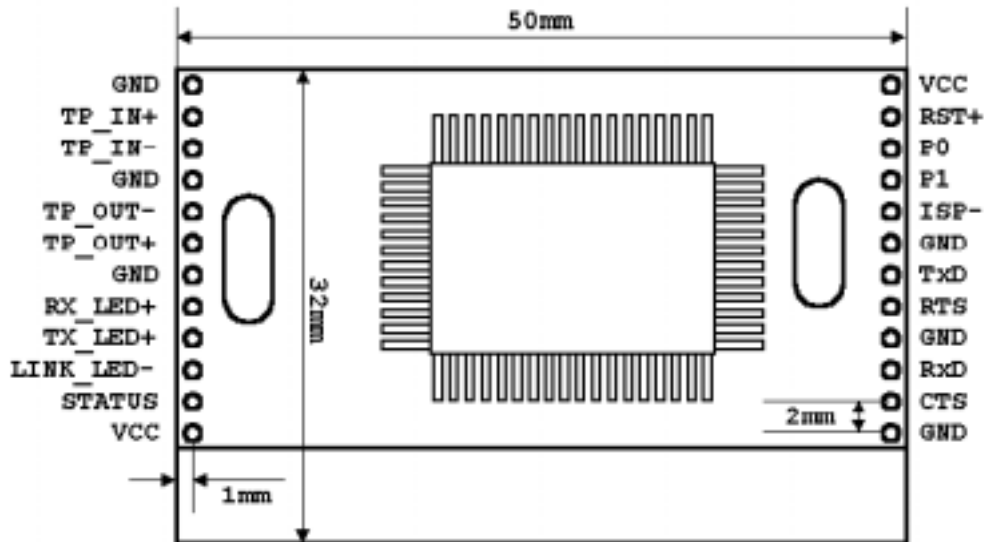

PIN NAME	Functions	I/O	Standard	Optional
TP_IN+	10Base-T Differential Input +	IN	●	
TP_IN-	10Base-T Differential Input -	IN	●	
TP_OUT-	10Base-T Differential Output -	OUT	●	
TP_OUT+	10Base-T Differential Output +	OUT	●	
RX_LED+	10Base-T RX Indicator	OUT		●
TX_LED+	10Base-T TX Indicator	OUT		●
LINK_LED-	10Base-T Link Indicator	OUT		●
STATUS	EZL-50 Status	OUT		●
RST+	Reset (Active High)	IN		●
P0	Connect Notifier (Active Low)	OUT		●
P1	reserved	-	-	-
ISP-	In System Programming (Active Low)	IN		●
TxD	UART TxD	OUT	●	
RTS	UART RTS	OUT		●
RxD	UART RxD	IN	●	
CTS	UART CTS	IN		●

* **ISP**: Maintaining the internal Pull-Up state and shifting to the firmware download state when LOW is input

* **P0**: LOW when the TCP connection continued / HIGH when the connection terminated

4.3. EZL-50 Schematic Diagram

