

MP126E M-417 Stage User Manual

Version: 1.0.0

Date: 25.06.2014



This document describes the following stage:

- **M-417.2PD**
Linear Translation Stage with Recirculating Ballscrew, Travel Range 500 mm, ActiveDrive DC Motor (Includes 24 V Power Supply)



Physik Instrumente (PI) GmbH & Co. KG is the owner of the following trademarks:
PI®, PIC®, PICMA®, PILine®, PIFOC®, PiezoWalk®, NEXACT®, NEXLINE®,
NanoCube®, NanoAutomation®, Picoactuator®, Plnano®

© 2014 Physik Instrumente (PI) GmbH & Co. KG, Karlsruhe, Germany. The text, photographs and drawings in this manual are protected by copyright. With regard thereto, Physik Instrumente (PI) GmbH & Co. KG retains all the rights. Use of said text, photographs and drawings is permitted only in part and only upon citation of the source.

Original instructions

First printing: 25.06.2014

Document number: MP126E, MMA, version 1.0.0

Subject to change without notice. This manual is superseded by any new release. The latest release is available for download (p. 3) on our website.



Contents

1	About this Document	1
1.1	Goal and Target Audience of this User Manual	1
1.2	Symbols and Typographic Conventions	1
1.3	Definition	2
1.4	Figures	3
1.5	Other Applicable Documents	3
1.6	Downloading Manuals	3
2	Safety	5
2.1	Intended Use	5
2.2	General Safety Instructions	5
2.3	Organizational Measures	6
3	Product Description	7
3.1	Product View	7
3.2	Product Labeling	8
3.3	Scope of Delivery	9
3.4	Accessories	9
3.5	Suitable Controllers	10
3.6	Technical Features	10
3.6.1	Limit Switches	10
3.6.2	Rotary Encoder	11
3.6.3	Reference Point Switch	12
3.6.4	Integrated PWM Amplifier	12
4	Unpacking	13
5	Installation	15
5.1	General Notes on Installation	15
5.2	Mounting the M-417 on a Surface	16
5.3	Affixing the Load to the M-417	20
5.3.1	Affixing the Load Directly on the Sled	21
5.3.2	Affixing the Load with the Mounting Adapter	22
5.4	Setting Up a Multi-Axis System	25
5.4.1	General Information on Setting Up a Multi-Axis System	25
5.4.2	Setting Up an XY System	25
5.4.3	Setting Up a Z System	28
5.5	Connecting the Motor Cable to the M-417	31
5.6	Connecting the Power Supply to the M-417	31

6	Start-Up	33
6.1	General Notes on Start-Up	33
6.2	Starting up the Stage	35
6.2.1	M-417 Entries in the Stage Database of PI	36
6.2.2	Operating Parameters	36
7	Maintenance	37
7.1	General Notes on Maintenance	37
7.2	Performing a Maintenance Run	37
7.3	Cleaning the M-417	38
8	Troubleshooting	39
8.1	Possible Causes and Correction	39
8.2	Manually Moving the Sled	41
9	Customer Service	43
10	Technical Data	45
10.1	Specifications	45
10.1.1	Data Table	45
10.1.2	Maximum Ratings	46
10.1.3	Ambient Conditions and Classifications	46
10.1.4	Limit Switch Specifications	47
10.1.5	Reference Point Switch Specifications	47
10.2	Dimensions	48
10.2.1	M-417 Stage	48
10.2.2	M-417.AP1 Mounting Adapter	49
10.3	Pin Assignment	50
10.3.1	Sub-D 15 (m) Controller Connection	50
10.3.2	M8 Power Supply Connector (m)	51
11	Old Equipment Disposal	53
12	EC Declaration of Conformity	55

1 About this Document

In this Chapter

Goal and Target Audience of this User Manual	1
Symbols and Typographic Conventions	1
Definition	2
Figures	3
Other Applicable Documents	3
Downloading Manuals	3

1.1 Goal and Target Audience of this User Manual

This manual contains information on the intended use of the M-417.

It assumes that the reader has a fundamental understanding of basic servo systems as well as motion control concepts and applicable safety procedures.

The latest versions of the user manuals are available for download (p. 3) on our website.

1.2 Symbols and Typographic Conventions

The following symbols and typographic conventions are used in this user manual:

WARNING



Possibly hazardous situation

If not avoided, the hazardous situation will result in serious injury.

- Actions to take to avoid the situation.

CAUTION



Dangerous situation

If not avoided, the dangerous situation will result in minor injury.

- Actions to take to avoid the situation.

NOTICE



Dangerous situation

If not avoided, the dangerous situation will result in damage to the equipment.

- Actions to take to avoid the situation.

INFORMATION

Information for easier handling, tricks, tips, etc.

Symbol/Label	Meaning
1. 2.	Action consisting of several steps whose sequential order must be observed
➤	Action consisting of one or several steps whose sequential order is irrelevant
▪	List item
p. 5	Cross-reference to page 5
RS-232	Labeling of an operating element on the product (example: socket of the RS-232 interface)
	Warning sign on the product which refers to detailed information in this manual.

1.3 Definition

Term	Explanation
Load capacity	Maximum load capacity in the vertical direction when the stage is mounted horizontally. The contact point of the load is in the center of the moving part of the stage (e. g. platform, sled).
Max. push/pull force	Maximum force in the direction of motion. Some stages may have higher forces but with limited lifetimes. In the case of vertical mounting, the specified value (p. 45) only applies when the servo mode is on.
Incremental position sensor	Sensor (encoder) for capturing changes of position or changes of angle. Signals from the incremental position sensor are used for axis position feedback. After switching on the controller a reference point definition must be performed before absolute target positions can be commanded and reached.

1.4 Figures

For better understandability, the colors, proportions and degree of detail in illustrations can deviate from the actual circumstances. Photographic illustrations may also differ and must not be seen as guaranteed properties.

1.5 Other Applicable Documents

The devices and software tools which are mentioned in this documentation are described in their own manuals.

Controller	Document
C-863.11 DC Motor Controller	MS205E User Manual
C-843 DC Motor Controller PCI Board	MS77E User Manual
C-884 DC Motor Controller	MS213E User Manual

1.6 Downloading Manuals

INFORMATION

If a manual is missing on our website or if there are problems in downloading:

- Contact our customer service department (p. 43).

The current versions of the manuals are found on our website. For some products (e.g. Hexapod systems and electronics that are delivered with a CD), access to the manuals is password-protected. The password is stored on the CD.

Download freely accessible manuals

1. Open the website <http://www.pi-portal.ws>.
2. Click **Downloads**.
3. Click the corresponding category (e.g. **M Hexapods / Micropositioning**).
4. Click the corresponding product code (e.g. **M-417**).
5. Click **Documents**.

The available manuals are displayed.

6. Click the desired manual and save it on the hard disk of your PC or on a data storage medium.

Download password-protected manuals

1. Carry out steps 1 to 5 of the download process for freely accessible manuals.
2. Insert the product CD in the PC drive.
3. Switch to the **Manuals** directory on the CD.
4. In the **Manuals** directory, open the Release News (file including **releasenews** in the file name).
5. Find the user name and password in the **User login for software download** section in the Release News.
6. In the **User login** area on the left margin in the website, enter the user name and the password in the corresponding fields.
7. Click **Login**.
The available manuals are displayed.
8. Click the desired manual and save it on the hard disk of your PC or on a data storage medium.

2 Safety

In this Chapter

Intended Use	5
General Safety Instructions	5
Organizational Measures.....	6

2.1 Intended Use

The M-417 is a laboratory device as defined by DIN EN 61010. It is intended to be used in interior spaces and in an environment which is free of dirt, oil and lubricants.

In accordance with its design and realization, the M-417 is intended for single-axis positioning, adjusting and shifting of loads at different velocities. The M-417 is **not** intended for applications in areas in which a failure would present severe risks to human beings or the environment.

The M-417 is intended for horizontal or vertical mounting. For the load limits with vertical mounting, see "General Notes on Installation" (p. 15).

The intended use of the M-417 is only possible when completely mounted and connected.

The M-417 must be operated with a suitable controller (p. 10). The controller is not included in the scope of delivery of the M-417.

2.2 General Safety Instructions

The M-417 is built according to state-of-the-art technology and recognized safety standards. Improper use can result in personal injury and/or damage to the M-417.

- Only use the M-417 for its intended purpose, and only use it if it is in a good working order.
- Read the user manual.
- Immediately eliminate any faults and malfunctions that are likely to affect safety.

The operator is responsible for the correct installation and operation of the M-417.

If the stage is operated without the protective cover, the entanglement of body parts or objects (e. g. hair, jewelry or clothing) by the rotating drive screw can lead to serious injury.

- Only start up the M-417 when the protective cover is properly affixed (p. 16).

There is a risk of minor injury from crushing between the moving parts of the stage or the load and a fixed part or obstacle.

- Use protective structures to keep limbs away from areas in which they could be seized by moving parts.
- Observe the safety distances in accordance with DIN EN ISO 13857 when installing protective structures.

2.3 Organizational Measures

User manual

- Always keep this user manual available by the M-417.
The latest versions of the user manuals are available for download (p. 3) on our website.
- Add all information given by the manufacturer to the user manual, for example supplements or Technical Notes.
- If you pass the M-417 on to other users, also turn over this user manual as well as other relevant information provided by the manufacturer.
- Only use the device on the basis of the complete user manual. Missing information due to an incomplete user manual can result in serious injury and property damage.
- Only install and operate the M-417 after having read and understood this user manual.

Personnel qualification

The M-417 may only be installed, started up, operated, maintained and cleaned by authorized and appropriately qualified personnel.

3 Product Description

In this Chapter

Product View 7
 Product Labeling..... 8
 Scope of Delivery 9
 Accessories 9
 Suitable Controllers 10
 Technical Features 10

3.1 Product View

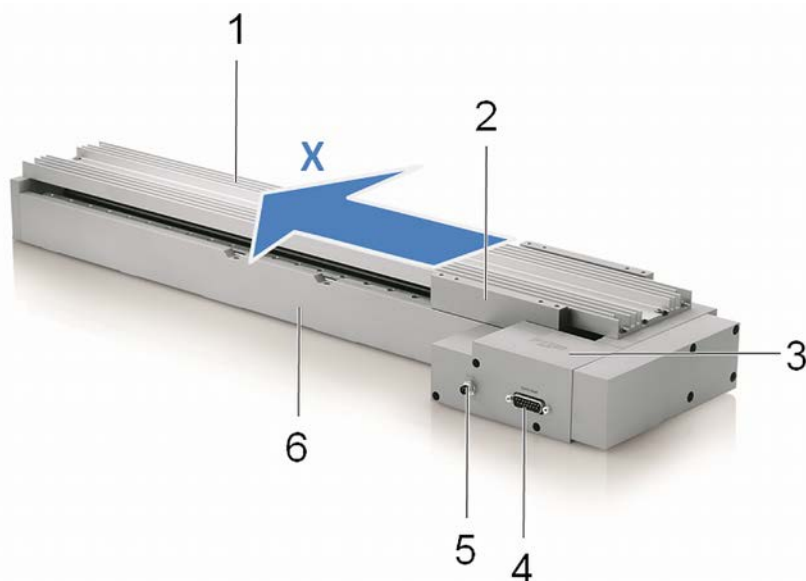

Figure 1: Components of the M-417.2PD stage

- 1 Protective cover
- 2 Moving sled
- 3 Motor cover
- 4 Controller connection (Sub-D 15 panel plug)
- 5 Power supply connection (M8 panel plug)
- 6 Base body
- x (Arrow:) Positive direction of motion (X axis)

3.2 Product Labeling

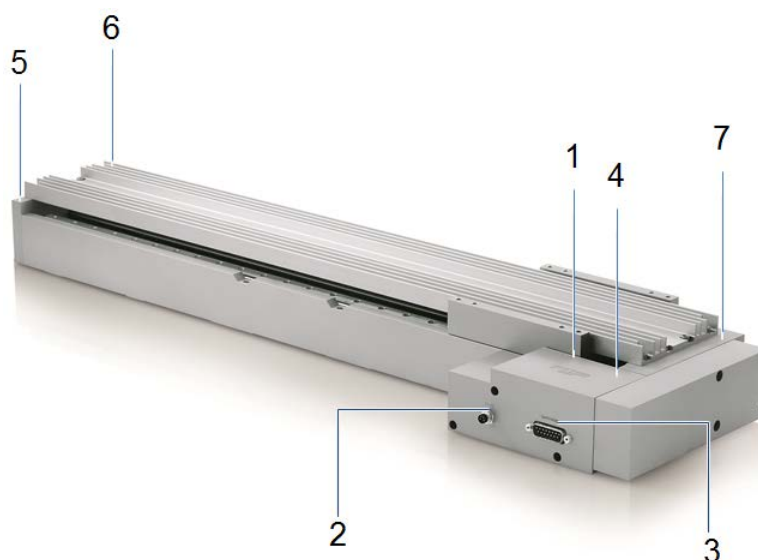

Figure 2: Product labeling, position

Position	Labeling	Description
1	PI	Manufacturer's logo
1	WWW.PI.WS	Manufacturer's address (website)
1	M-417.2PD	Product name
1	SN: A13045786	Serial number (example), individual for each M-417 Meaning of the places (counting from left): 1 = internal information, 2 and 3 = manufacturing year, 4 to 9 = consecutive numbers
1	Country of origin: Germany	Country of origin
1		Warning sign "Observe manual!"
1		Old equipment disposal (p. 53)
1	CE	CE conformity mark
2	24 VDC	Power supply connection
3	Controller	Controller connection
4-7		"Risk of crushing" warning sign

3.3 Scope of Delivery

Item ID	Component
M-417.2PD	Stage according to order
M-417.AP1	Mounting adapter for setting up a multi-axis system and for alternative affixing of the load
000049049	Screw set for attaching the stage, load and mounting adapters <ul style="list-style-type: none"> ▪ 4 M4x12-A2 hex-head cap screws ISO 4762 ▪ 4 M5x12-A2 hex-head cap screws ISO 4762 ▪ 4 M5x45-A2 hex-head cap screws ISO 4762 ▪ 4 M5x50-A2 hex-head cap screws ISO 4762 ▪ 6 M6x25-A2 hex-head cap screws ISO 4762 ▪ Allen wrench AF 3 DIN 911 ▪ Allen wrench AF 4 DIN 911 ▪ Allen wrench AF 5 DIN 911
C-815.38	Motor cable, 3 m, Sub-D 15 (m/f)
MP119EK	Short instructions for stages with electric motors
000023194	Wide-range-input power supply 24 V / 120 W
3763	Power cord
K050B0003	Adapter for the power supply connection; barrel connector to M8 4-pin connector (f)

3.4 Accessories

Order Number	Description
C-815.83	Motor cable, 10 m, Sub-D, 15-pin (m/f)

To order, contact our customer service department (p. 43).

3.5 Suitable Controllers

The M-417 must be connected to a suitable controller. The following controllers from PI are suitable for the operation of the M-417:

Controller	Axes per controller	PC interface	Multiple controllers on the same PC
C-843	2 or 4	Internal (PCI bus)	Yes, separate boards
C-863	1	USB, RS-232, daisy chain	Yes, same interface
C-884	1 to 4	USB, RS-232, TCP/IP	Yes

PC software is included in the scope of delivery of the controllers from PI. The operation of the controllers is described in the corresponding user manuals.

3.6 Technical Features

3.6.1 Limit Switches

The M-417 is equipped with noncontact, Hall-effect limit switches. The signals of the limit switches are used to stop the sled before the hard stop at both ends of the travel range.

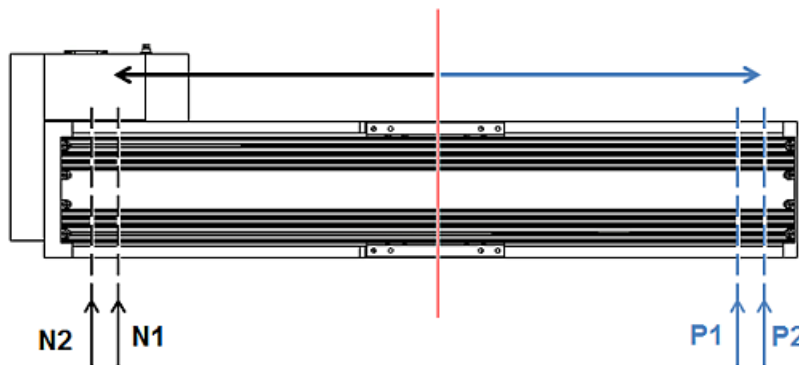

Figure 3: Limit switch arrangement with the M-417

- N1 Inner negative limit switch
- N2 Outer negative limit switch
- P1 Inner positive limit switch
- P2 Outer positive limit switch

Limit switch function with the M-417:

Limit switch*	Availability of the signal	Function
"Inner" limit switches N1 and P1	Output to the controller on the Sub-D 15 panel plug (p. 50) See also "Limit Switch Specifications" (p. 47).	When triggering takes place, the controller switches off the servo mode for the affected axis and thereby stops the motion. The sled can be moved away from the limit switch by command, see "Possible Causes and Correction" (p. 39).
"Outer" limit switches N2 and P2	No connection to the controller	The triggering interrupts the power source of the drive via a relay. The sled cannot be moved away from the limit switch by command but must be moved manually (p. 41).

The distance between N1 and N2 or P1 and P2 is approx. 5.3 mm in each case.

INFORMATION

In the case of controllers from PI, the permissible travel range of the stage is represented via parameters in the controller. Suitable parameter values can be loaded from a stage database in the supplied PC software; see also "M-417 Entries in the Stage Database of PI" (p. 36). With the values loaded from the stage database for the lower and upper limit of the travel range, the limit switches **cannot** be approached with motion commands. The controller furthermore calculates the dynamic profile during the motion so that the stage decelerates in time before the end of the permissible travel range. The stage can only reach the limit switch in exceptional cases, e.g. with a very high velocity and/or under high load.

For details, see the user manual of the controller.

3.6.2 Rotary Encoder

The M-417 is equipped with an optical rotary encoder. For the encoder resolution, refer to the table in the "Specifications" section (p. 45).

A rotary encoder is implemented at a rotating point in the drivetrain, e.g. the motor shaft.

3.6.3 Reference Point Switch

The stage is equipped with a direction-sensing reference point switch that is located approximately in the middle of the travel range. This sensor transmits a TTL signal that indicates whether the stage is on the positive or negative side of the reference point switch.

The commands that use the reference signal are described in the user manual of the controller and/or in the corresponding software manuals.

3.6.4 Integrated PWM Amplifier

The M-417 is equipped with a PWM amplifier ("ActiveDrive concept"). The motor and PWM amplifier are installed in a common case and thus optimally integrated and shielded. The PWM amplifier only receives the control signals from the controller, whereas the supply voltage is provided via an external power supply. The ActiveDrive concept allows a high motor power and dynamics with a low loss of power.

4 Unpacking

1. Unpack the M-417 with care.
2. Compare the contents against the items covered by the contract and against the packing list.
3. Inspect the contents for signs of damage. If parts are missing or you notice signs of damage, contact PI immediately.
4. Keep all packaging materials in case the product needs to be returned.

5 Installation

In this Chapter

General Notes on Installation	15
Mounting the M-417 on a Surface	16
Affixing the Load to the M-417	20
Setting Up a Multi-Axis System	25
Connecting the Motor Cable to the M-417	31
Connecting the Power Supply to the M-417.....	31

5.1 General Notes on Installation

NOTICE



Unintentional changes in position with vertical mounting!

If the load exceeds the self-locking of the drive when the stage is mounted vertically, unintentional changes in the position of the sled will occur. Unintentional changes in the position of the sled can damage the drive, the load or the environment.

- When a stage is mounted vertically, make sure that the installed load is less than 10 N.

NOTICE



Protruding screw heads!

Protruding screw heads can damage the M-417.

- Ensure that the screw heads do not protrude from counter-sunk holes so that they do not interfere with the stage motion.

NOTICE



Cable break!

A cable break leads to a failure of the stage.

- Install the stage so that the cable is not bent or squeezed too severely during operation.

NOTICE



Heating up of the M-417 during operation!

The heat produced during operation of the M-417 can affect your application.

- Install the M-417 so that your application is not affected by the dissipating heat.

INFORMATION

For optimum repeatability, all components must be affixed without backlash.

- Make sure that the stage, load and - if present - the mounting adapter are affixed without backlash.
- If possible, carry out a simulation of the stage motions with a mounted load or suitable calculations in order to identify collisions or unfavorable center of gravity constellations.
- If necessary, take suitable constructive measures to avoid collisions and instabilities in the overall system.
- Avoid or mark danger zones that result from the installation of the stage and the application, in accordance with the legal regulations.

5.2 Mounting the M-417 on a Surface

NOTICE



Warping of the M-417 due to mounting on uneven surfaces!

Mounting the M-417 on an uneven surface can warp the M-417. Warping reduces the accuracy.

- Mount the M-417 on an even surface. The recommended evenness of the surface is $\leq 10 \mu\text{m}$.
- For applications with great temperature changes:
Only mount the M-417 on surfaces that have the same or similar thermal expansion properties as the M-417.

INFORMATION

The positive direction of motion is away from the cable exit side.

INFORMATION

The following holes in the base body of the stage can be used to mount the M-417 on a surface:

- $\varnothing 5.5 \text{ mm}$ holes
- $\varnothing 6.6 \text{ mm}$ holes

Prerequisites

- You have read and understood the general notes on installation (p. 15).
- You have provided a suitable surface (for the required position and depth of the holes for accommodating the screws, see "Dimensions" (p. 48)):
 - When the Ø 5.5 mm holes are used: Four M5 holes with sufficient depth are present.
 - When the Ø 6.6 mm holes are used: Six M6 holes with sufficient depth are present.
 - The evenness of the surface is $\leq 10 \mu\text{m}$.
 - For applications with great temperature changes: The surface should have the same thermal expansion properties as the M-417 (e.g. surface made of aluminum).
- You have accounted for the space required for a cable routing free of kinks and in accordance with regulations.
- The stage is **not** connected to the power supply and the controller.

Tools and accessories

When the Ø 5.5 mm holes are used; mounting accessories in the scope of delivery (p. 9):

- 4 M5x50 screws
- Allen wrench AF 4

When the Ø 6.6 mm holes are used; mounting accessories in the scope of delivery (p. 9):

- 6 M6x25 screws
- Allen wrench AF 5
- Allen wrench AF 4 for manually moving the sled
- Allen wrench AF 3 for removing and affixing the protective cover

Mounting the stage on Ø 5.5 mm holes

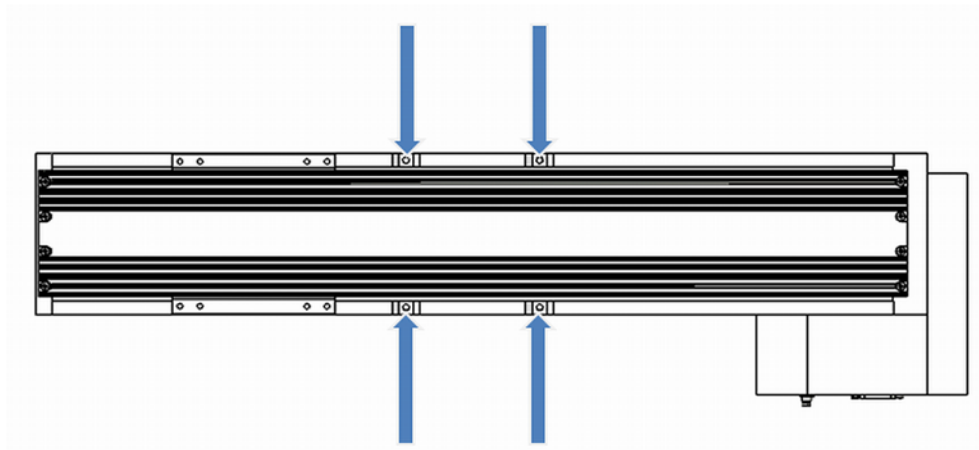

Figure 4: Position of the Ø 5.5 mm mounting holes in the base body of the stage

1. If necessary, make the Ø 5.5 mm mounting holes in the base body of the stage accessible by manually moving the sled (p. 41).
2. Align the stage on the surface so that the corresponding mounting holes in the stage and the surface overlap.
3. Screw the screws into all mounting holes.
4. Make sure that the screw heads do not protrude from the counter-sunk holes.
5. Check that the stage fits on the surface without backlash.

Mounting the stage on Ø 6.6 mm holes

1. Remove the protective cover:

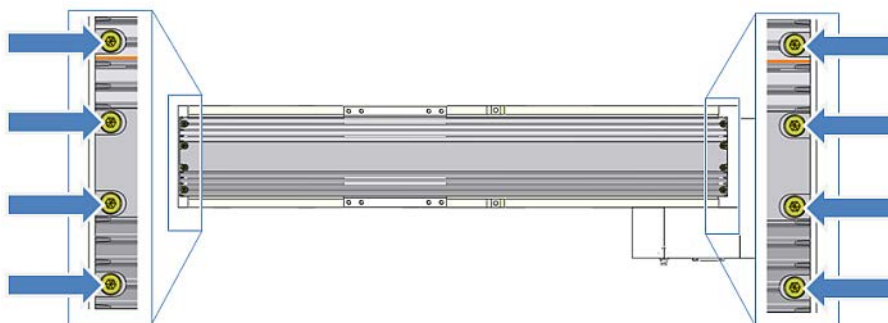

Figure 5: Position of the screws for affixing the protective cover

- a) Loosen the eight M4x8 mounting screws with which the protective cover is affixed to the M-417 (see figure).
- b) Remove the loosened screws.
- c) Remove the protective cover.

2. If necessary, make the $\varnothing 6.6$ mm mounting holes in the base body of the stage accessible by manually moving the sled (p. 41).

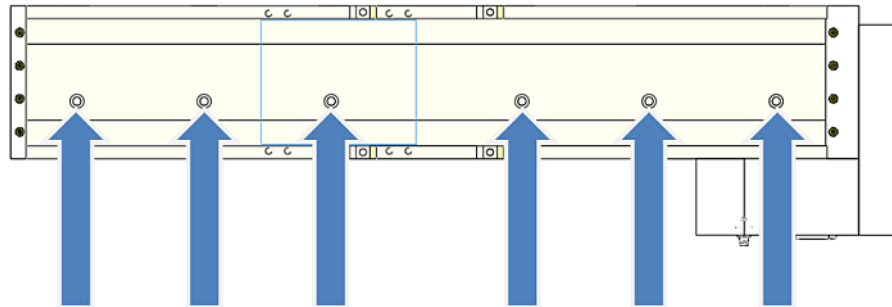

Figure 6: Position of the $\varnothing 6.6$ mm mounting holes in the base body of the stage (protective cover removed, sled slightly indicated)

3. Align the stage on the surface so that the corresponding mounting holes in the stage and the surface overlap.
4. Screw the screws into all mounting holes.
5. Make sure that the screw heads do not protrude from the counter-sunk holes.
6. Check that the stage fits on the surface without backlash.
7. Affix the protective cover to the stage:
 - a) Place the protective cover on the base body of the stage so that the corresponding holes overlap.
 - b) Screw in the eight M4x8 screws completely.
 - c) Check that the protective cover fits without backlash.

5.3 Affixing the Load to the M-417

NOTICE



Impermissibly high load on the stage!

An impermissibly high load interferes with the motion of the sled and can damage the stage.

- For the mounting type and mass of the load, observe the maximum permissible forces that are allowed to act on the sled according to the specification (p. 45).

INFORMATION

You can affix a load on the M-417 in the following ways:

- Directly on the moving sled. Advantages: More compact structure, lower total weight, lower moving mass, shorter total set-up time
- On the M-417.AP1 mounting adapter, which is affixed to the moving sled. Advantages: More mounting options, easier optimization of the center of gravity in the case of inhomogeneous loads

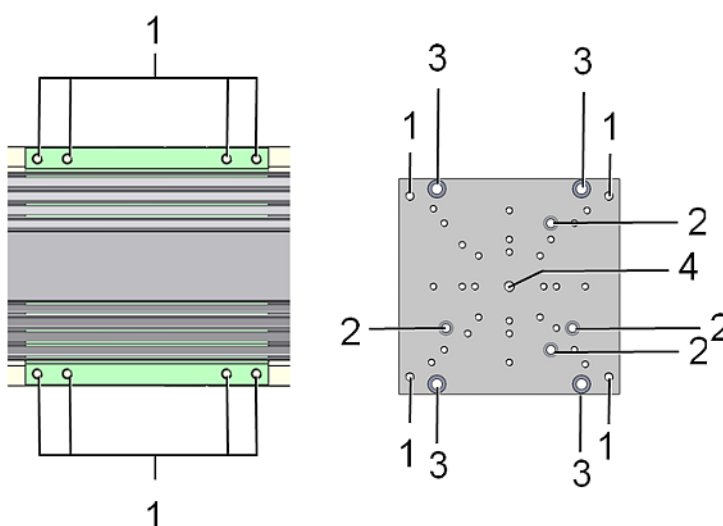

Figure 7: Holes in the moving sled (left) and in the M-417.AP1 mounting adapter (right, shown transparent)

- 1 M5 (for affixing the load or mounting a further stage as the Y axis (p. 25))
- 2 \varnothing 4.8 mm (for affixing the load or mounting a further stage as the Z axis (p. 28))
- 3 \varnothing 5.45 mm (for affixing the mounting adapter to the moving sled)
- 4 M6 (for affixing the load in the center)

Other holes in the mounting adapter: M4 (for affixing the load), 28 pieces

Exact position and depth of the holes: See "Dimensions" (p. 48).

5.3.1 Affixing the Load Directly on the Sled

NOTICE



Contact between the load and the protective cover of the stage!

Contact between the load and the protective cover of the stage interferes with the motion of the sled and can damage the stage and/or load.

- Design the load so that no contact is possible between the load and the protective cover.

NOTICE



Warping of the sled!

Unsuitable affixing of the load can warp the sled of the M-417. Warping of the sled will increase wear and reduce accuracy.

- Only affix loads with an even surface to the sled. The recommended evenness of the load surface is 50 µm.
- For applications with great temperature changes: Only affix loads on the sled that have the same or similar thermal expansion properties as the M-417 (e. g. loads made of aluminum).

NOTICE



Screws that are too long!

Screws that are inserted too deeply can damage the M-417.

- Observe the depth of the mounting holes in the sled of the stage.
- Only use screws of the correct length for the respective mounting holes.

Prerequisites

- You have read and understood the general notes on installation (p. 15).
- You have properly attached the stage to a surface (p. 16).
- The stage is **not** connected to the power supply and the controller.
- You have prepared the load so that it can be affixed to the mounting holes in the sled of the stage:
 - The center of gravity of the load is positioned as centrally as possible on the sled.
 - At least two points are provided for affixing the load to the sled (ideally: three or four attachment points).

Tools and accessories

- At least 2 M5 screws with suitable length (4 M5x12 screws in the scope of delivery (p. 9))
- Suitable tools for fastening the screws (Allen wrench AF 4 in the scope of delivery (p. 9))

Affixing the load directly to the sled

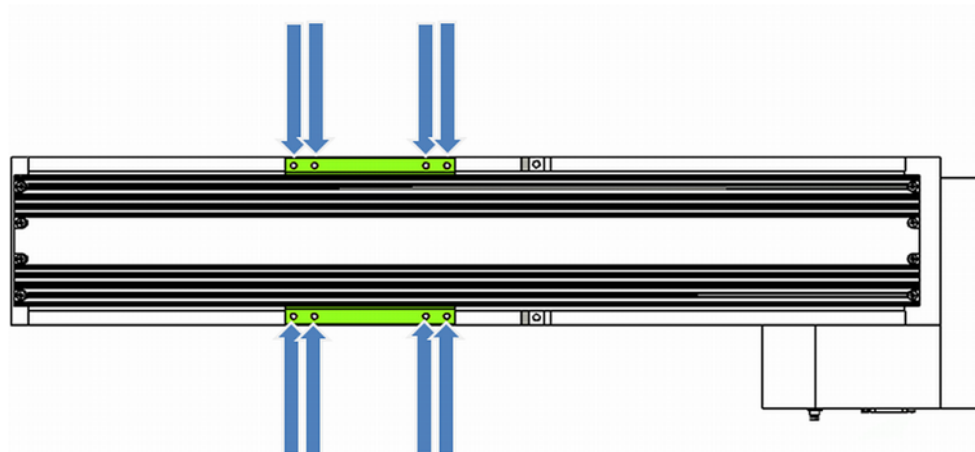

Figure 8: Position of the mounting holes for the load (M5 depth 10 mm) on the sled of the stage

1. Align the load so that the selected mounting holes in the sled can be used for affixing it.

The arrangement of the mounting holes in the sled of the stage can be found in the above figure as well as in the dimensional drawing (p. 48).
2. Affix the load to the selected mounting holes in the sled using the screws.
3. Check that the load fits on the sled without backlash.

5.3.2 Affixing the Load with the Mounting Adapter

NOTICE



Screws that are too long!

Screws that are inserted too deeply can damage the M-417.

- Observe the depth of the mounting holes in the sled of the stage.
- Only use screws of the correct length for the respective mounting holes.
- Avoid that screws protrude into the space between the bottom side of the mounting adapter and the protective cover of the M-417.

INFORMATION

The sequence of the following mounting steps depends on the dimensions of the load and the selection of the mounting holes in the mounting adapter:

- Affixing the mounting adapter to the sled of the M-417
- Affixing the load to the mounting adapter
- Select the sequence of the mounting steps according to the configuration of your set-up.

Prerequisites

- You have read and understood the general notes on installation (p. 15).
- You have properly attached the stage to a surface (p. 16).
- The stage is **not** connected to the power supply and the controller.
- You have prepared the load so that it can be affixed to the mounting holes in the mounting adapter:
 - The distance between the center of gravity of the load and the center of the mounting adapter is as small as possible in all directions.
 - At least two points are provided for affixing the load to the mounting adapter (ideally: three or four attachment points).

Tools and accessories

- M-417.AP1 mounting adapter, in the scope of delivery (p. 9)
- Mounting accessories for affixing the mounting adapter to the sled, in the scope of delivery (p. 9)
 - 4 M5x12 screws
 - Allen wrench AF4
- At least 2 screws of suitable length for affixing the load on the mounting adapter. Options:
 - M4 screws (for mounting from below or above)
 - M5 screws (for mounting from above)
 - M6 screw (for mounting from above)
- Suitable tools for fastening the screws

Affixing the mounting adapter to the sled

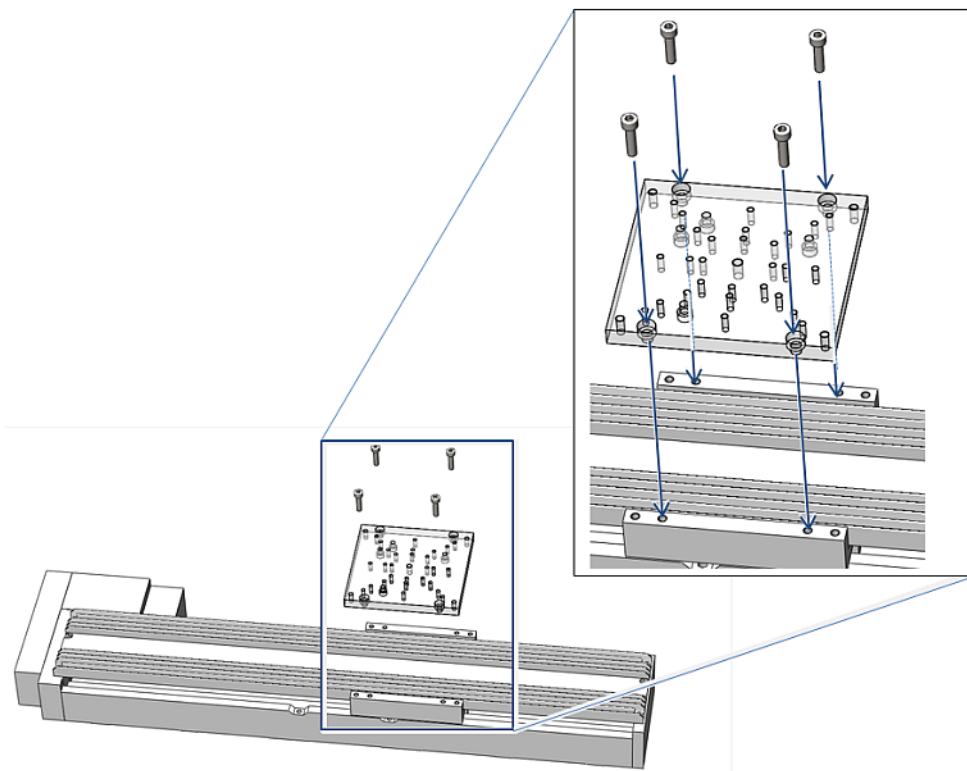

Figure 9: Affixing the mounting adapter (shown transparent) to the sled

1. Position the M-417.AP1 mounting adapter on the sled of the M-417 (see figure above):
 - The counterbores in the required holes of the mounting adapter are pointing upwards.
 - The required holes in the mounting adapter and sled overlap.
2. Completely screw one M5x12 screw into each of the holes.
3. Check that the mounting adapter fits on the sled of the stage without backlash.

Affixing the load to the mounting adapter

1. Align the load so that the selected mounting holes in the mounting adapter can be used to affix it.
2. Affix the load to the selected mounting holes (p. 20) in the mounting adapter using the appropriate screws.
3. Make sure that the screw heads do not protrude from the counter-sunk holes.
4. Check that the load fits on the mounting adapter without backlash.

5.4 Setting Up a Multi-Axis System

5.4.1 General Information on Setting Up a Multi-Axis System

NOTICE



Impermissibly high forces and torques!

Impermissibly high forces and torques that are applied to the stages in a multi-axis system can damage the stages.

- Include the masses of the moved stages and mounting adapters in the calculation of the load to be moved.
- For the mounting type and mass of the load, observe the maximum permissible forces according to the specifications for the individual stages.
- Avoid tilting torques on the sled of the M-417 and the moving platforms of the other stages: For the individual stages, make sure that the load is positioned as centrally as possible on the sled or the moving platform.
- When the motion axis of the stage is oriented vertically, make sure that the installed load is lower than the holding force of the drive.

- Only install and operate the multi-axis system after you have read and understood the user manuals of all components of the multi-axis system.
- If you require special mounting adapters, contact our customer service department (p. 43).

Possible combinations

The following stages from PI can be combined with the M-417:

- M-403
- M-404
- M-413
- M-414

The listed stages can each be mounted on the M-417 as either a Y or Z axis.

5.4.2 Setting Up an XY System

NOTICE



Screws that are too long!

Mounting from below: Screws that are inserted too deeply can damage the M-417.

- Observe the depth of the mounting holes in the base body of the M-417 (p. 48).
- Only use screws of the correct length for the respective mounting holes.

Designations in these instructions:

- **Lower stage:** M-417, forms the basis of the multi-axis system (X axis), is attached to a surface
- **Upper stage:** Forms the Y-axis of the multi-axis system, is attached to the lower stage rotated by 90°

Prerequisites

- You have read and understood the general notes on installation (p. 15).
- You have read and understood the general notes on setting up a multi-axis system (p. 25).
- You have accounted for the space required for a cable routing free of kinks and in accordance with regulations.
- The used stages are disconnected from the power supply and controller.
- You have properly attached the lower stage to a surface (p. 16).

Tools and accessories

- M-417.AP1 mounting adapter, in the scope of delivery (p. 9)
- 4 M5x12 screws for affixing the mounting adapter to the sled, in the scope of delivery (p. 9)
- M-403, M-404, M-413 or M-414 stage as the Y axis ("upper stage")
- 4 M5x45 screws for mounting the upper stage on the mounting adapter, in the scope of delivery (p. 9)
- Allen wrench AF 4, in the scope of delivery (p. 9)

Setting up an XY system

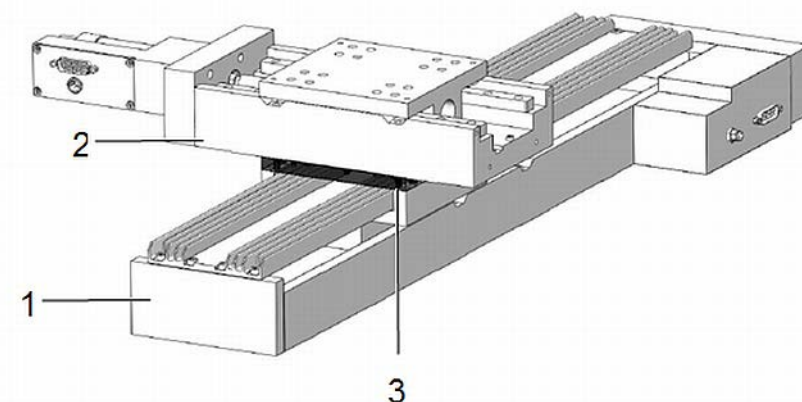

Figure 10: XY system

- 1 Lower stage (M-417)
- 2 Upper stage (here: M-413.1xx or M-414.1xx)
- 3 Mounting adapter (M-417.AP1)

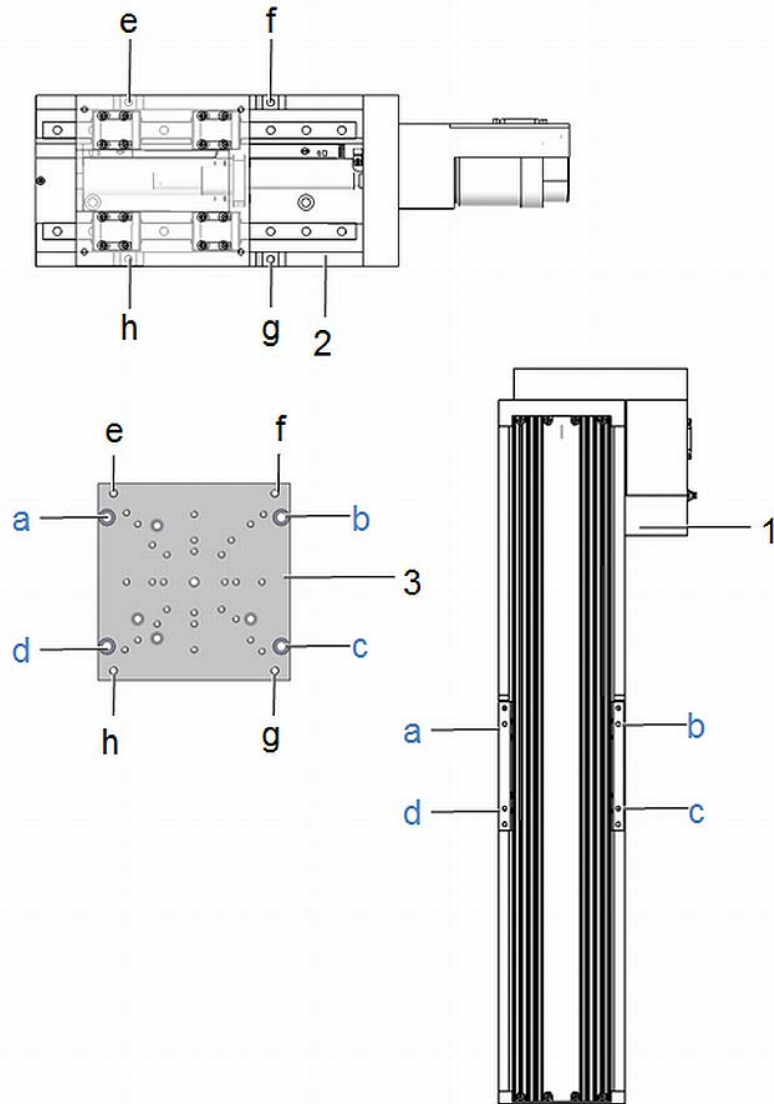

Figure 11: Setting up an XY system

- 1 Lower stage (M-417)
- 2 Upper stage (platform shown semi-transparent)
- 3 M-417.AP1 mounting adapter

a-h: Mounting holes:

Holes that overlap during attachment are marked with the same letter

1. Affix the mounting adapter to the sled of the lower stage (M-417) according to the instructions in "Affixing the Load with the Mounting Adapter" (p. 22).
2. If necessary: Make the required mounting holes in the base body of the upper stage accessible. Possible measures:
 - Temporary start-up of the upper stage and commanding the platform to a suitable position
 - If possible: Manually move the platform of the upper stage (see manual of the upper stage)

3. Position the upper stage on the mounting adapter so that the holes **e** to **h** overlap (see figure above).
4. Completely screw one M5x45 screw into each of the holes.
5. Check that the upper stage fits on the mounting adapter without backlash.

5.4.3 Setting Up a Z System

NOTICE



Screws that are too long!

Screws that are inserted too deeply can damage the M-417.

- Observe the depth of the mounting holes in the sled of the stage.
- Only use screws of the correct length for the respective mounting holes.

Designations in these instructions:

- **Lower stage:** M-417, forms the basis of the multi-axis system (X axis), is attached to a surface.
- **Upper stage:** Forms the Z axis of the multi-axis system, is mounted in a vertical alignment to the lower stage.
- **Transverse mounting** and **longitudinal mounting:** Marking of the orientation of the upper stage, see following table.

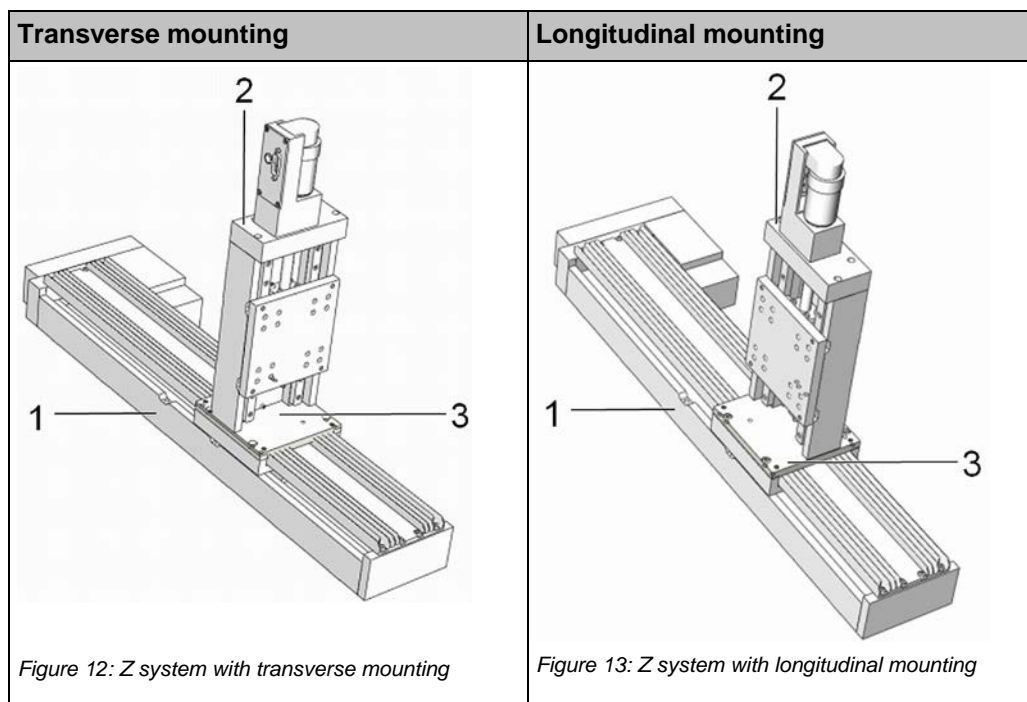

- 1 Lower stage (M-417)
- 2 Upper stage (here: M-413.1xx or M-414.1xx)
- 3 Mounting adapter (M-417.AP1)

Prerequisites

- You have read and understood the general notes on installation (p. 15).
- You have read and understood the general notes on setting up a multi-axis system (p. 25).
- You have accounted for the space required for a cable routing free of kinks and in accordance with regulations.
- The used stages are disconnected from the power supply and controller.
- You have properly attached the lower stage to a surface (p. 16).

Tools and accessories

- M-417.AP1 mounting adapter, in the scope of delivery (p. 9)
- M-403, M-404, M-413 or M-414 stage as the Z axis ("upper stage")
- 2 M4x12 screws for affixing the upper stage to the mounting adapter, in the scope of delivery (p. 9)
- Allen wrench AF 3, in the scope of delivery (p. 9)
- 4 M5x12 screws for affixing the mounting adapter to the lower stage, in the scope of delivery (p. 9)
- Allen wrench AF 4, in the scope of delivery (p. 9)

Setting up a Z system

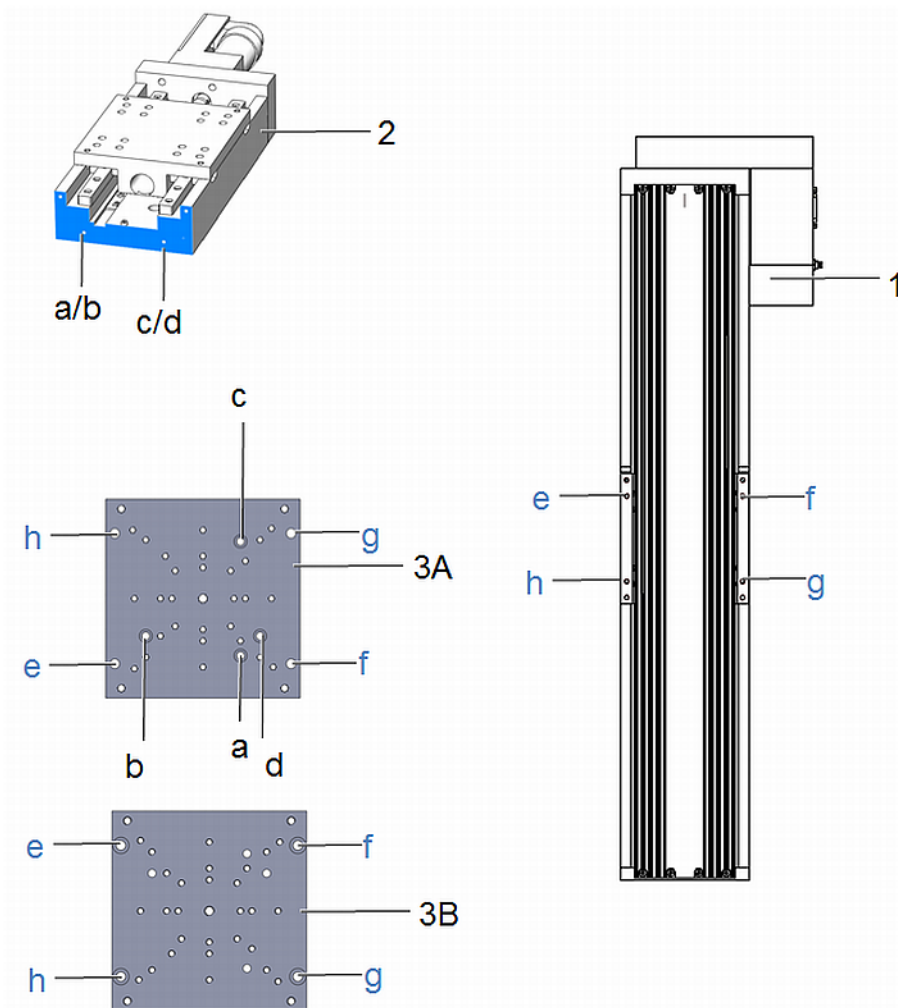

Figure 14: Holes for mounting the Z axis

- 1 Lower stage (M-417)
- 2 Upper stage
- 3 Mounting adapter (M-417.AP1; 3A: Bottom side, 3B: Top side)
- a-g: Mounting holes:
 - a, c: For longitudinal mounting
 - b, d: For transverse mounting
 - Holes that overlap during mounting are marked with the same letter

1. Affix the mounting adapter to the upper stage.
 - a) Align the mounting adapter on the front side of the upper stage:
 - The top side of the mounting adapter points to the upper stage.
 - For transverse mounting: Holes **b** and **d** overlap.
 - For longitudinal mounting: Holes **a** and **c** overlap.
 - b) Screw one M4x12 screw into each of the selected holes.

- c) Make sure that the screw heads do not protrude from the counter-sunk holes.
 - d) Check that the mounting adapter fits on the upper stage without backlash.
2. Affix the mounting adapter to the lower stage (M-417):
 - a) Position the mounting adapter to which the upper stage is affixed on the sled of the lower stage: The required mounting holes in the mounting adapter and sled of the lower stage overlap (holes **e** to **h**).
 - b) Completely screw one M5x12 screw into each of the holes.
 - c) Check that the mounting adapter fits on the lower stage without backlash.

5.5 Connecting the Motor Cable to the M-417

Prerequisites

- You have read and understood the general notes on installation (p. 15).
- The motor cable is not connected to the controller.

Tools and accessories

- Suitable motor cable from PI, e.g.:
 - Motor cable C-815.38, 3 m, Sub-D, 15-pin (m/f), in the scope of delivery (p. 9).
 - Motor cable C-815.83, 10 m, Sub-D, 15-pin (m/f), available as optional accessory (p. 9).

Connecting the motor cable to the M-417

1. Connect the connector (f) of the motor cable to the Sub-D 15-pin panel plug (m) of the stage.
2. Secure the connector (f) with the two integrated screws against being unintentionally pulled out of the stage.

5.6 Connecting the Power Supply to the M-417

Prerequisites

- The power cord is **not** connected to the power socket.

Tools and accessories

- Included 24 V wide-range-input power supply (for line voltages between 100 and 240 VAC at 50 or 60 Hz)
- Alternatively: Sufficiently dimensioned power supply that provides 24 VDC with a maximum of 5.0 ampere
- Included adapter for the power supply connection; barrel connector to M8 4-pin connector (f)
- Alternatively: Sufficiently dimensioned adapter

- Included power cord
- Alternatively: Sufficiently dimensioned power cord

Connecting the power supply to the M-417

- Connect the M8 connector (f) of the adapter with the M8 panel plug of the M-417.
- Connect the barrel connector of the adapter to the barrel connector socket of the power supply.
- Connect the power cord to the power supply.

6 Start-Up

In this Chapter

General Notes on Start-Up.....	33
Starting up the Stage.....	35

6.1 General Notes on Start-Up

WARNING



Entanglement hazard by rotating drive screw!

If the stage is operated without the protective cover, the entanglement of body parts or objects (e. g. hair, jewelry or clothing) by the rotating drive screw can lead to serious injury.

- Only start up the M-417 when the protective cover is properly affixed (p. 16).

CAUTION



Risk of crushing by moving parts!

There is a risk of minor injury from crushing between the movable parts of the stage or the load and a fixed part or obstacle.

- Use protective structures to keep limbs away from areas in which they could be seized by moving parts.
- Observe the safety distances in accordance with DIN EN ISO 13857 when installing protective structures.

NOTICE



Damage from collisions!

Collisions can damage the stage, the load to be moved and the environment.

- Make sure that no collisions are possible between the stage, the load to be moved and the environment in the motion range of the stage.
- Do not place any objects in areas where they can get caught by moving parts.
- Stop the motion immediately if a controller malfunction occurs.
- If possible, adapt the travel range limits of your mechanical system in the software that you use for commanding the motion.

NOTICE**Damage if an incorrect controller is connected!**

Connecting a stage to an unsuitable controller can cause damage to the stage or controller.

- Connect a stage with DC motor to a DC motor controller only.
- If you use controllers and software from other manufacturers, check their technical data to make sure that they are suitable before starting up the stage!

NOTICE**Operating voltage too high or incorrectly connected!**

Operating voltages that are too high or incorrectly connected can cause damage to the M-417.

- Do **not** exceed the operating voltage range (p. 46) for which the M-417 is specified.
- Only operate the M-417 when the operating voltage is properly connected; see "Pin Assignment" (p. 50).

NOTICE**Damage or considerable wear from high accelerations!**

High accelerations can cause damage to or considerable wear on the mechanical system.

- Stop the motion immediately if a controller malfunction occurs.
- Ensure that the end of the travel range is approached at low velocity.
- Determine the maximum velocity for your application.

NOTICE**Unintentional motions!**

When the M-417 is being connected to the controller, it can carry out unintentional motions. Defective software or wrong operation of the software can also result in unintentional motions.

- Do not place any objects in areas where they can get caught by moving parts.
- Before connecting the M-417, check whether a macro is defined as the start-up macro in the controller, and cancel the selection of the start-up macro if necessary.

INFORMATION

The repeatability of the positioning is only ensured when the reference point switch is always approached from the same side. Controllers from PI fulfill this requirement as a result of the automatic direction sensing for reference moves to the reference switch.

INFORMATION

Unsuitable settings made to the servo-control parameters can impair the performance of the M-417. This can have the following consequences:

- Oscillations
- Imprecise approach of the position
- Settling time is too long
- If the performance of the M-417 is not satisfactory, check the settings for the servo-control parameters of your controller.

6.2 Starting up the Stage

Prerequisites

- You have read and understood the General Notes on Start-Up (p. 33).
- For starting up with a load or in a multi-axis system: You have properly installed the stage (p. 25).
- You have read and understood the user manual of the used controller.
- You have read and understood the manual of the used PC software.
- The controller and the required PC software have been installed. All connections on the controller have been set up (see user manual of the controller; the stage is connected via the motor cable).

Starting up the stage

1. Connect the power cord of the power supply with the power socket.
2. Start up the controller (see user manual of the controller).

Configure the controller during the start-up using the PC software for the used stage (see user manual of the controller and of the PC software)

- If you use a controller from PI: Select the entry in the stage database that precisely fits the used stage model (p. 36).
 - If you use a controller from another manufacturer: Enter the parameters (p. 36) that precisely fit the used stage model in the corresponding PC software.
3. Start a few motion cycles for testing purposes (see user manual of the controller).

6.2.1 M-417 Entries in the Stage Database of PI

For controllers from PI, you can select the connected stage from a stage database in the corresponding PC software. The appropriate operating parameters are thus loaded to the controller. You can find a detailed description in the user manual for the controller or in the manual for the PC software used.

6.2.2 Operating Parameters

If you use a DC motor controller from a third-party supplier, it may be necessary to enter operating parameters for adaptation to the used stage.

Parameter	M-417	Unit
P-Term	180	-
I-Term	45	-
D-Term	300	-
I-Limit	2000	-
Maximum acceleration	200000	counts/s ²
Maximum velocity	100	mm/s
Maximum velocity	200000	counts/s
Gear ratio	-	-
Encoder resolution	2000	counts/mm
Limit switch polarity	Active high	-

7 Maintenance

In this Chapter

General Notes on Maintenance.....	37
Performing a Maintenance Run.....	37
Cleaning the M-417	38

7.1 General Notes on Maintenance

NOTICE



Damage due to improper maintenance!

Improper maintenance can lead to misalignment and failure of the M-417.

- Only loosen screws according to the instructions in this manual.

7.2 Performing a Maintenance Run

Depending on the operating conditions and the period of use of the M-417, the following maintenance measures are required:

Maintenance run

The maintenance run serves to distribute the lubricant that is present.

- After 500 operating hours or at least after 1 year, carry out a maintenance run over the entire travel range, in order for the lubricant present to be equally distributed.
- If you operate your stage continuously over only a small working range (<20% of the entire travel range), perform a run across the entire travel range approximately every 2000 motion cycles.

Lubrication

- Under laboratory conditions, the stage needs extra lubrication in exceptional cases only. For continuous industrial use, the lubrication intervals must be defined individually.
- Do **not** lubricate the M-417 without consulting our customer service department (p. 43).
- To lubricate, follow the instructions given in the maintenance manual which you can obtain from our customer service department.

7.3 Cleaning the M-417**Prerequisites**

- You have disconnected the stage from the controller.

Cleaning the stage

- When necessary, clean the stage surface with a cloth lightly dampened with a mild cleanser or disinfectant.
- Do **not** use any organic solvents.

8 Troubleshooting

In this Chapter

Possible Causes and Correction	39
Manually Moving the Sled	41

8.1 Possible Causes and Correction

Problem	Possible Causes	Solution
Reduced positioning accuracy	Warped base body	➤ Mount the M-417 on an even surface. The recommended evenness of the surface is 10 µm.
	When the stage is mounted vertically: The load exceeds the self-locking of the drive.	➤ Reduce the load. Make sure that the load does not exceed 10 N.
	Increased wear due to small motions over a long period of time	➤ Carry out a maintenance run over the entire travel range (p. 37).
Functional impairment after system modification	<ul style="list-style-type: none"> ▪ Controller has been replaced. ▪ M-417 has been replaced with another model. 	<p>Controller from PI:</p> <ul style="list-style-type: none"> ➤ Load the parameters from the stage database that correspond to the combination of controller and M-417 model. <p>Controller from a third-party supplier:</p> <ul style="list-style-type: none"> ➤ Check the operating parameters.

Problem	Possible Causes	Solution
Mechanical system does not move; no operating noise can be heard.	Controller and/or power supply are incorrectly connected or defective.	<ul style="list-style-type: none"> ➤ Check all connection cables. ➤ Check the controller. ➤ Check the power supply of the stage.
	When a PI controller is used: A motion error of the axis is present.	<p>Motion error = The difference between the current position and the commanded position exceeds the prescribed maximum value in closed-loop operation. Motion errors can be caused, for example, by malfunctions of the drive or the position sensor of the stage.</p> <ol style="list-style-type: none"> 1. Read out the error code of the controller in the PC software. If a motion error is present, the error code -1024 is output. 2. Check your system and make sure that all axes can be moved safely. 3. Switch on the servo mode for the affected axis in the PC software. <p>For details, see the user manual of the controller.</p>
	Sled has triggered the "inner" limit switch (p. 10).	<p>If you use a controller from PI:</p> <ol style="list-style-type: none"> 1. Switch on the servo mode for the affected axis again in the PC software. 2. Command an axis motion away from the limit switch in the PC software.
Sled has triggered the "outer" limit switch (p. 10).	<ul style="list-style-type: none"> ➤ Manually move the sled away from the limit switch. (p. 41) 	

If the problem that occurred with your system is not listed in the table above or cannot be solved as described, contact our customer service department (p. 43).

8.2 Manually Moving the Sled

INFORMATION

In the following cases, it can be necessary to manually move the sled:

- Make mounting holes in the base body of the stage accessible.
- Move the sled away from the outer limit switch in order to make the stage operational again.

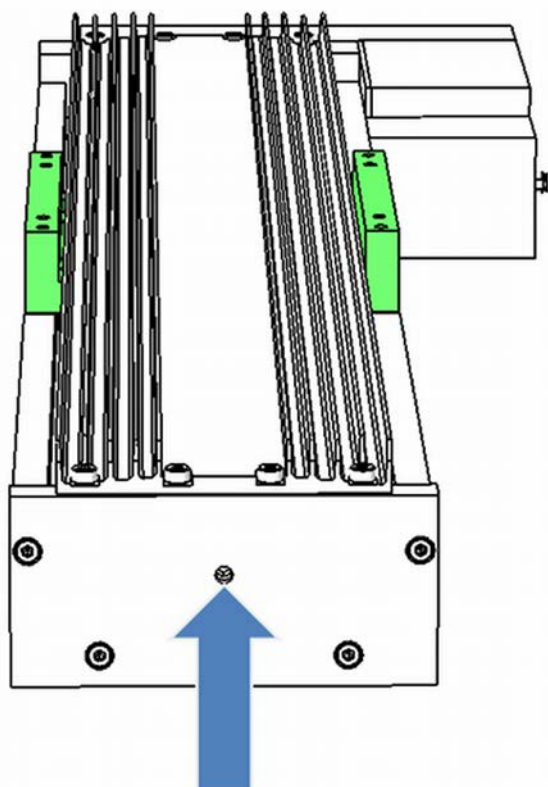

Figure 15: Position of the drive screw access

Prerequisites

- ✓ The stage is **not** connected to the power supply and the controller.

Tools

- Allen wrench AF 4, in the scope of delivery (p. 9)

Manually moving the sled

1. Introduce the Allen wrench into the drive screw access until you feel resistance.
2. Rotate the Allen wrench as far as necessary:
 - Clockwise rotation: Sled moves towards the drive screw access
 - Counter-clockwise rotation: Sled moves away from the drive screw access

The rotary motion is transferred directly to the drive screw.

9 Customer Service

For inquiries and orders, contact your PI sales engineer or send us an e-mail (<mailto:info@pi.ws>).

If you have questions concerning your system, have the following information ready:

- Product codes and serial numbers of all products in the system
- Firmware version of the controller (if present)
- Version of the driver or the software (if present)
- Operating system on the PC (if present)

The latest versions of the user manuals are available for download (p. 3) on our website.

10 Technical Data

In this Chapter

Specifications	45
Dimensions	48
Pin Assignment.....	50

10.1 Specifications

10.1.1 Data Table



	M-417.2PD	Unit
Motion and positioning		
Travel range	500	mm
Integrated sensor	Rotary encoder	
Sensor resolution	4000	cts./rev.
Design resolution	0.5	μm
Min. incremental motion	0.5	μm
Unidirectional repeatability	0.5	μm
Backlash	2	μm
Crosstalk, angular error	±100	μrad
Max. velocity	100	mm/s
Mechanical properties		
Thread pitch	2	mm
Gear ratio	–	
Max. load	500	N
Max. push / pull force	200	N
Max. lateral force	200	N

Drive properties		
Motor type	DC motor with PWM control	
Operating voltage	24 (PWM)	V
Motor power	70	W
Reference point and limit switches	Hall effect	
Miscellaneous		
Operating temperature range	-20 to 65	°C
Material	Aluminum, steel	
Mass	10.5	kg
Connector	Sub-D 15-pin, 3 m cable incl.	
Recommended controller / driver	C-863 (single-axis), C-884 (up to 4 axes)	

Ask about custom designs!

10.1.2 Maximum Ratings

The M-417 is designed for the following maximum ratings:

Maximum Operating Voltage 	Operating Frequency 	Maximum Power Consumption 
24 V	0 Hz	70 W

10.1.3 Ambient Conditions and Classifications

The following ambient conditions and classifications must be observed for the M-417:

Area of application	For indoor use only
Maximum altitude	2000 m
Relative humidity	Max. 80 % for temperatures up to 31 °C Decreasing linearly to 50 % at 40 °C
Storage temperature	-20 °C to 80 °C
Transport temperature	-20 °C to 80 °C
Supply fluctuations	Not more than ± 10 % of the nominal voltage
Degree of pollution	2
Degree of protection according to IEC 60529	IP40

10.1.4 Limit Switch Specifications

Type	Magnetic (Hall-effect) sensor
Supply voltage	+5 V/GND, supply via the motor connector
Signal output	TTL level
Signal logic	Active high. When the limit switch is passed, the signal level changes: <ul style="list-style-type: none">– Normal motor operation: low (0 V)– Limit switch reached: high (+5 V)

10.1.5 Reference Point Switch Specifications

Type	Magnetic (Hall-effect) sensor
Supply voltage	+5 V/GND
Signal output	TTL level
Signal logic	Direction sensing by means of different signal levels on the left and right side of the reference point switch: The signal level changes from 0 to +5 V when the reference point switch is passed.

10.2 Dimensions

10.2.1 M-417 Stage

Dimensions in mm. Note that the decimal places are separated by a comma in the drawings.

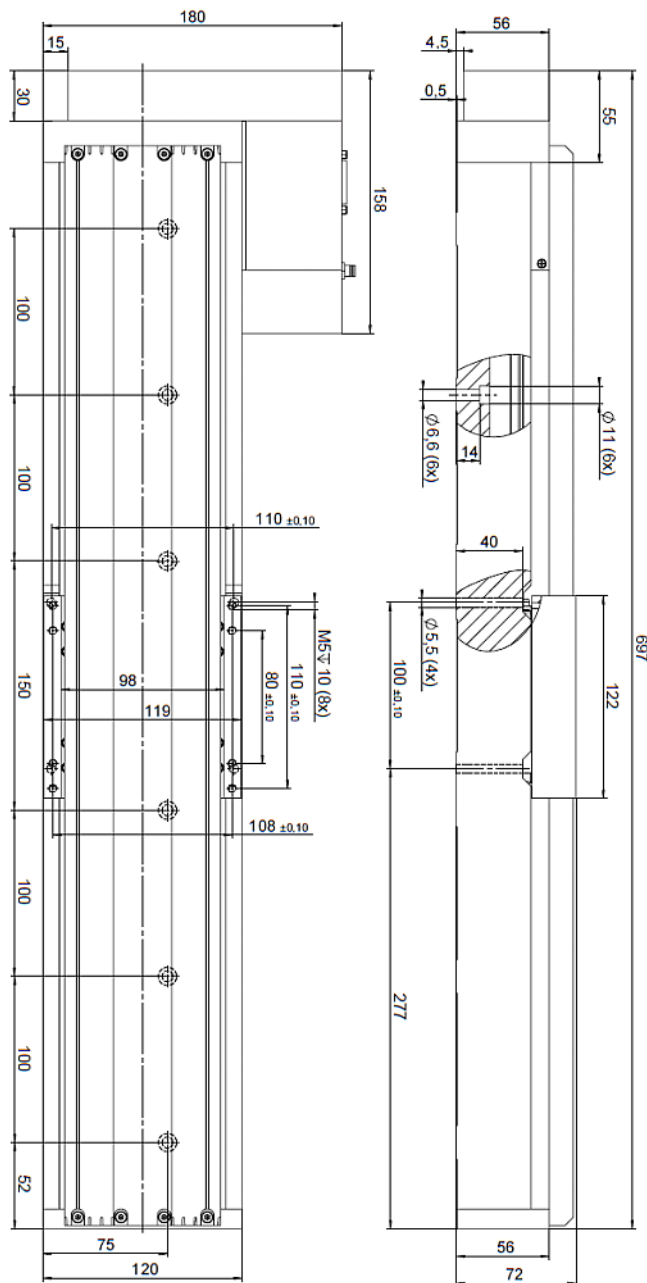

Figure 16: M-417 dimensions, sled in reference position

10.2.2 M-417.AP1 Mounting Adapter

Dimensions in mm. Note that the decimal places are separated by a comma in the drawings.

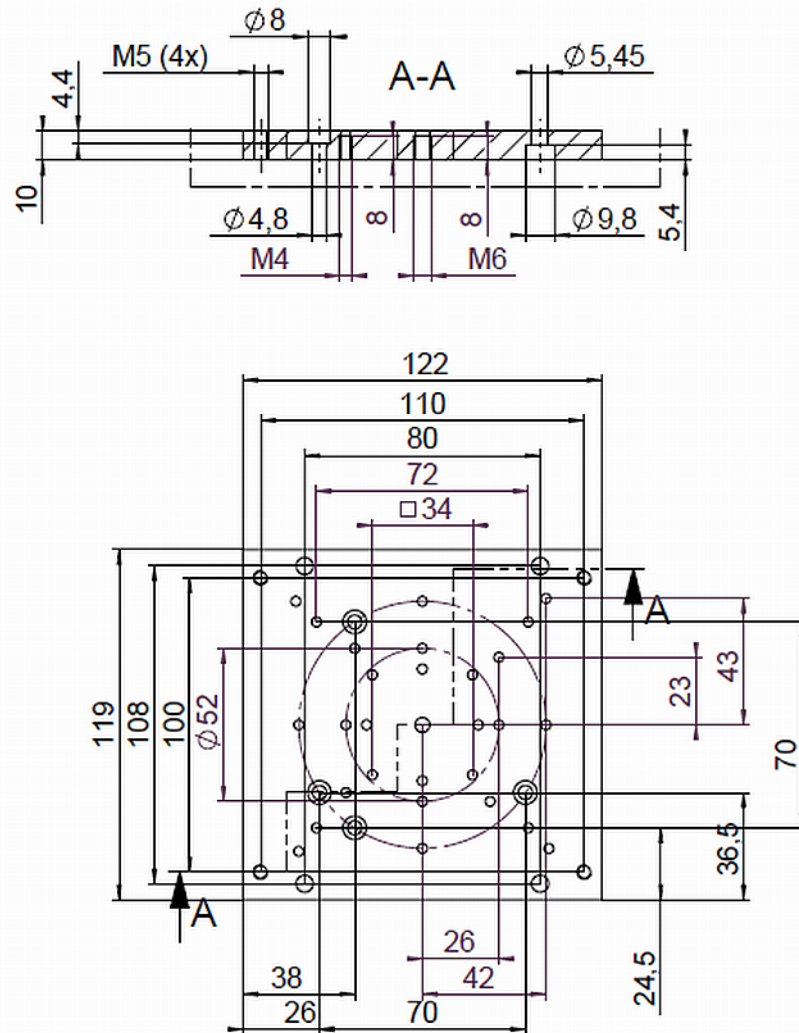

Figure 17: Dimensions of the M-417.AP1 mounting adapter

10.3 Pin Assignment

10.3.1 Sub-D 15 (m) Controller Connection

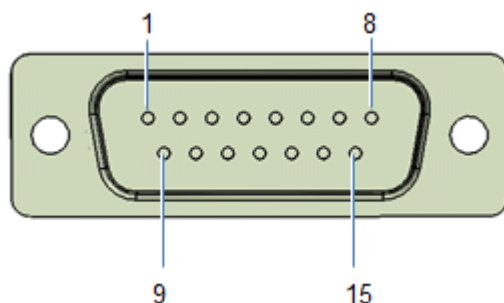

Figure 18: Sub-D 15 (m) controller connection, front view

Pin	Signal	Direction
1	- (not connected)	-
9	- (not connected)	-
2	- (not connected)	-
10	GND	GND
3	MAGN (PWM magnitude)	Input
11	SIGN (PWM sign)	Input
4	+ 5 V	Input
12	Limit_N (negative limit switch)	Output
5	Limit_P (positive limit switch)	Output
13	Reference	Output
6	ID chip (for future use)	Bidirectional
14	Encoder A (+)	Output
7	Encoder A (-)	Output
15	Encoder B (+)	Output
8	Encoder B (-)	Output

10.3.2 M8 Power Supply Connection (m)

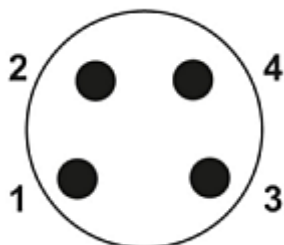

Figure 19: Phoenix M8 panel plug, front view

Pin	Signal	Direction
1	GND	GND
2	GND	GND
3	24 VDC supply voltage	Input
4	24 VDC supply voltage	Input

11 Old Equipment Disposal

In accordance with the applicable EU law, electrical and electronic equipment may not be disposed of with unsorted municipal wastes in the member states of the EU.

When disposing of your old equipment, observe the international, national and local rules and regulations.

To meet the manufacturer's product responsibility with regard to this product, Physik Instrumente (PI) GmbH & Co. KG ensures environmentally correct disposal of old PI equipment that was first put into circulation after 13 August 2005, free of charge.

If you have old PI equipment, you can send it postage-free to the following address:

Physik Instrumente (PI) GmbH & Co. KG

Auf der Römerstr. 1

D-76228 Karlsruhe, Germany



12 EC Declaration of Conformity

For the M-417, an EC Declaration of Conformity has been issued in accordance with the following European directives:

2006/42/EC, Machinery Directive

2004/108/EC, EMC Directive

2011/65/EU, RoHS Directive

The applied standards certifying the conformity are listed below.

Safety of Machinery: EN 12100:2010

Electrical Safety: EN 61010-1:2010

EMC: EN 61326-1:2013

RoHS: EN 50581:2012

