

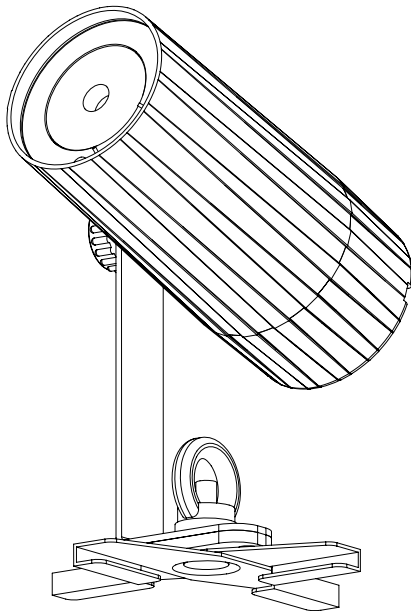

# PINPOINT GO TW



## *User Instructions*

©2015 ADJ Products, LLC all rights reserved. Information, specifications, diagrams, images, and instructions herein are subject to change without notice. ADJ Products, LLC logo and identifying product names and numbers herein are trademarks of ADJ Products, LLC. Copyright protection claimed includes all forms and matters of copyrightable materials and information now allowed by statutory or judicial law or hereinafter granted. Product names used in this document may be trademarks or registered trademarks of their respective companies and are hereby acknowledged. All non-ADJ Products, LLC brands and product names are trademarks or registered trademarks of their respective companies.

**ADJ Products, LLC** and all affiliated companies hereby disclaim any and all liabilities for property, equipment, building, and electrical damages, injuries to any persons, and direct or indirect economic loss associated with the use or reliance of any information contained within this document, and/or as a result of the improper, unsafe, insufficient and negligent assembly, installation, rigging, and operation of this product.

Europe Energy Saving Notice

Energy Saving Matters (EuP 2009/125/EC)

Saving electric energy is a key to help protecting the environment. Please turn off all electrical products when they are not in use. To avoid power consumption in idle mode, disconnect all electrical equipment from power when not in use. Thank you!

## PinPoint GO TW

## Introduction

**Unpacking:** Thank you for purchasing the PinPoint GO TW by ADJ Products, LLC. Every PinPoint GO TW has been thoroughly tested and has been shipped in perfect operating condition. Carefully check the shipping carton for damage that may have occurred during shipping. If the carton appears to be damaged, carefully inspect your fixture for any damage and be sure all accessories necessary to operate the unit has arrived intact. In the case damage has been found or parts are missing, please contact our toll free customer support number for further instructions. Do not return this unit to your dealer without first contacting customer support.

**Introduction:** The ADJ PinPoint GO TW is part of a continuing pursuit to create high quality intelligent lighting. The PinPoint GO TW is a bright, battery powered, LED pinspot.

**Customer Support:** ADJ provides a customer support line, to provide set up help and to answer any question should you encounter problems during your set up or initial operation. You may also visit us on the web at [www.adj.com](http://www.adj.com) for any comments or suggestions. Service Hours are Monday through Friday 8:00 a.m. to 4:30 p.m. Pacific Standard Time.

Voice: (323) 582-3322  
Fax: (323) 582-3108  
E-mail: [support@americandj.com](mailto:support@americandj.com)

**Warning!** To prevent or reduce the risk of electrical shock or fire, do not expose this unit to rain or moisture.

**Caution!** There are no user serviceable parts inside this unit. Do not attempt any repairs yourself, doing so will void your manufactures warranty. In the unlikely event your unit may require service please contact ADJ Products, LLC.

**PLEASE recycle the shipping carton when ever possible.**

## PinPoint GO TW

## General Instructions

To optimize the performance of this product, please read these operating instructions carefully to familiarize yourself with the basic operations of this unit. These instructions contain important safety information regarding the use and maintenance of this unit. Please keep this manual with the unit, for future reference.

## PinPoint GO TW

## Features

- DC Powered and Battery Powered
- Dimming 0-100%
- Fast Color Fade & Change and Slow Color Fade & Change,
- ADJ LED RC3 Compatible (Sold Separately)

## PinPoint GO TW

## Warranty Registration

The PinPoint GO TW carries a two year limited warranty. Please fill out the enclosed warranty card to validate your purchase. All returned service items whether under warranty or not, must be freight pre-paid and accompany a return authorization (R.A.) number. The R.A. number must be clearly written on the outside of the return package. A brief description of the problem as well as the R.A. number must also be written down on a piece of paper included in the shipping carton. If the unit is under warranty, you must provide a copy of your proof of purchase invoice. You may obtain a R.A. number by contacting our customer support team on our customer support number. All packages returned to the service department not displaying a R.A. number on the outside of the package will be returned to the shipper.

## PinPoint GO TW

## Cleaning

Due to fog residue, smoke, and dust cleaning the internal and external optical lenses must be carried out periodically to optimize light output.

1. Use normal glass cleaner and a soft cloth to wipe down the outside casing.
2. Clean the external optics with glass cleaner and a soft cloth every 20 days.
3. Always be sure to dry all parts completely before plugging the unit back in.

Cleaning frequency depends on the environment in which the fixture operates (i.e. smoke, fog residue, dust, dew).

- To reduce the risk of electrical shock or fire, do not expose this unit rain or moisture
- Do not spill water or other liquids into or on to your unit.
- Be sure that the local power outlet match that of the required voltage for your unit.
- Do not attempt to operate this unit if the power cord has been frayed or broken. Do not attempt to remove or break off the ground prong from the electrical cord. This prong is used to reduce the risk of electrical shock and fire in case of an internal short.
- Disconnect from main power before making any type of connection.
- Do not remove the cover under any conditions. There are no user serviceable parts inside.
- Never operate this unit when it's cover is removed.
- Never plug this unit in to a dimmer pack
- Always be sure to mount this unit in an area that will allow proper ventilation. Allow about 6" (15cm) between this device and a wall.
- Do not attempt to operate this unit, if it becomes damaged.
- This unit is intended for indoor use only, use of this product outdoors voids all warranties.
- During long periods of non-use, disconnect the unit's main power.
- Always mount this unit in safe and stable matter.
- Power-supply cords should be routed so that they are not likely to be walked on or pinched by items placed upon or against them, paying particular attention to the point they exit from the unit.
- Cleaning -The fixture should be cleaned only as recommended by the manufacturer. See page 3 for cleaning details.
- Heat -The appliance should be situated away from heat sources such as radiators, heat registers, stoves, or other appliances (including amplifiers) that produce heat.
- The fixture should be serviced by qualified service personnel when:
  - A. The power-supply cord or the plug has been damaged.
  - B. Objects have fallen, or liquid has been spilled into the appliance.
  - C. The appliance has been exposed to rain or water.
  - D. The appliance does not appear to operate normally or exhibits a marked change in performance.

## 1. Handling of Batteries

### 1.1 Do Not Short Circuit the Battery

Try to never short circuit the battery. It generates a very high current which could cause the battery to overheat which may result in electrolyte gel leakage, harmful fumes, or explosion. The LIR tabs may easily short-circuit by placing them on conductive surface. A short circuit may lead to heat build up and damage of the battery. An appropriate circuitry with PCM is employed to protect accidental short circuit of the battery pack.

### 1.2 Mechanical shock

Dropping the unit, impact hit, bending, etc. may cause failure or short-end life of the LIR battery.

## 2. Other

### 2.1 Battery connection

- 1). Direct soldering of wire leads or devices to the battery is strictly prohibited.
- 2). Lead tabs with pre-soldered wiring shall be spot welded to the batteries. Direct soldering may cause damage of components, such as separator and insulator, by heat build up.

### 2.2 Prevention of short circuit within a battery pack

There is enough insulation layers between wiring and the batteries to provide extra safety protection. The battery pack is constructed in a way that no short circuit will occur which may cause smoke or fire.

### 2.3 Do No Disassemble the Batteries

- 1). Never disassemble the batteries.  
Doing this may cause a internal short circuit in the battery, which may lead to harmful fumes, fire, explosion, or other problems.

- 2). Electrolyte Gel is harmful  
Electrolyte Gel should not leak from the LIR battery. Should the electrolyte gel come into contact with the skin or eyes, flush the area of contact immediately with fresh water and seek medical attention immediately.

### 2.4 Do Not Expose the Battery to Heat or Fire

Never incinerate or dispose of the batteries in fire. This may cause an explosion, which would be very dangerous.

**2.5 Do Not Expose the Battery to water or liquids**

Never soak/drop the batteries in liquids such as water, seawater, drinks such as soft drinks, juices, coffee or other.

**2.6 Battery Replacement**

For battery replacement please contact ADJ customer support (800) 322-6337.

**2.7 Do Not use a damaged Battery**

The battery could be damaged during shipping, caused by shock. Should the battery be found damaged, including damages to the plastic casing of the battery, deformation of the battery package, smelling of an electrolyte, or leakage of the electrolyte gel, or other, DO NOT use the battery. A battery with a odor of electrolyte or a gel leakage should be placed away from fire to avoid fire or explosion.

**3. Battery Storage**

When storing the battery, it should be stored at room temperature, with a charge of at least 50%. We recommend that during long periods of storage that the battery be charged every 6 months. Doing this will prolong the life of the battery and will also make sure that the battery charge does not fall below the 30% mark.

**4. Other Chemical Reaction**

Because batteries utilize a chemical reaction, battery performance will deteriorate over time even if stored for a long period of time without being used. In addition, if the various usage conditions such as charge, discharge, ambient temperature, etc. are not maintained within the specified ranges, the life expectancy of the battery maybe shortened or the device in which the battery is used may be damaged by electrolyte gel leakage. If the batteries cannot maintain a charge for long periods of time, even when they are charged correctly, this may indicate it is time to change the battery.

**5. Battery Disposal**

Please dispose of battery according to local regulations.

**Energy Saving Mode:**

There are 2 ways you can set the PinPoint GO TW into energy saving mode. When the PinPoint GO TW is set into energy saving mode, it will decrease the LED brightness gradually when the battery life is less than 80% to extend the battery life.

**NOTE:When the unit is using DC power, the energy saving mode cannot be used.**

1. Press the MODE button for 5 seconds to switch between normal mode and energy saving mode. When all the LED's flash 2 times, the PinPoint GO TW is in normal mode. When the Amber LED flashes for 5 seconds the PinPoint GO TW is in energy saving mode.
2. Using the ADJ LED RC3, press the BLACKOUT button for 5 seconds to switch between normal mode and energy saving mode. When all the LED's flash 2 times, the PinPoint GO TW is in normal mode. When the Amber LED flashes for 5 seconds the PinPoint GO TW is in energy saving mode.

**Low Battery Warning:**

When the battery power gets below 30%, the Warm White & Amber LED's will alternately flash rapidly for 5 seconds each time the power is switched ON. After the 5 seconds, the unit will function normally. This is a warning letting you know that you must charge the unit soon.

**Battery Recharge:**

To recharge the battery, plug the supplied DC power supply into the DC input located on the rear of the unit and plug the other end into a matching power supply. It takes about 4.5 hours to reach full charge with the power switch off.

**Operating Power:**

There are two ways to supply power to this unit; battery power or DC power.

- DC Power - To run the unit using DC power, plug the unit into a DC power source, and put the POWER switch into the ON position.
- Battery Power - To run the unit using Battery power, put the POWER switch in the ON position.

**Mode Button Lock:**

**The MODE button will lock itself after 30 seconds if nothing is pressed. To unlock the unit, press the MODE button for 3 seconds.**

**Mode Operation:**

Each press of the MODE button will cycle through the different operating modes. The operating modes are listed below in the order that they appear. See the Color Temperature chart for a list of the different color macros.

**NOTE: When power is turned OFF and turned back ON, the unit will start in the last operating mode.**

**Order of Operating Modes:**

• Color Temperature Macros • Fast Fade • Fast Change • Slow Fade • Slow Change

Pressing the MODE button again after Slow Change will return the unit to the first color temperature setting. Starting the operating mode order at the beginning.

| Color # | Color Temperature | CW  | WW  | Amber |
|---------|-------------------|-----|-----|-------|
| 1       | 2700K             | 11  | 255 | 255   |
| 2       | 3000K             | 91  | 255 | 255   |
| 3       | 3300K             | 114 | 225 | 255   |
| 4       | 3600K             | 227 | 255 | 255   |
| 5       | 3900K             | 255 | 255 | 134   |
| 6       | 4200K             | 255 | 255 | 44    |
| 7       | 4500K             | 255 | 208 | 0     |
| 8       | 4800K             | 255 | 130 | 0     |
| 9       | 5100K             | 255 | 80  | 0     |
| 10      | 5400K             | 255 | 46  | 0     |
| 11      | 5700K             | 255 | 21  | 0     |
| 12      | 6000K             | 255 | 0   | 0     |

The **ADJ LED RC3** infrared remote (Sold Separately) has many different functions and gives you complete control of your PinPoint GO TW. To control the your desired fixture you must aim the controller at the front of the fixture and be no more the 30 feet away.

**BLACKOUT** - Pressing this button will blackout the fixture. This button is also used to switch between normal mode and energy saving mode. Press the button for at least five seconds, when the Amber LED flashes for five seconds you are in energy saving mode, when the cool white LED flashes two times you are in normal mode.

**SELECT PROG (PROGRAM)** - Press this button scroll through slow color fade, fast color fade, slow color change, and fast color change. Press the Speed button and use the "+" & "-" buttons to adjust the program speed. Press the Flash button to activate strobing and use the "+" & "-" buttons to adjust the strobe speed.

**MANUAL COLOR MODE** - Press the WW/CW/A buttons to select one of the three colors. Use the "+" & "-" buttons to adjust the output intensity. Press the Flash button to activate strobing and use the "+" & "-" buttons to adjust the strobe speed.

**COLOR SELECT MODE** - Press the "1" button to activate color select mode. Use the "+" & "-" buttons to scroll through the 12 color temperatures of the Color Temperature Chart. Press the Flash button to activate strobing and use the "+" & "-" buttons to adjust the strobe speed.

## PinPoint GO TW

## Frost Filter Install

The PinPoint GO TW comes with a frost filter. To install the filter carefully remove the retainer ring in front of the lens. Install the filter and replace the retainer ring. Make sure the filter cut out for the infrared receiver is in the correct place.

## PinPoint GO TW

## Installation

The unit has two ways that it can be installed. The unit includes a X-Clip so that it can be installed on drop down ceilings. Always ensure that the unit is firmly fixed to avoid vibration and slipping while operating. Always ensure that the structure to which you are attaching the unit is secure and is able to support a weight of 10 times the unit's weight. Always use a safety cable that can hold 12 times the weight of the unit when doing this type of installation. The safety cable should go through the eye hole nut that holds the X-Clip base in place.

You can also install using the magnetic base. To do this, remove the X-Clip base by unscrewing the eye hole bolt. Once removed the fixture can be stuck to anything magnetic.

**The equipment must be installed by a professional, and it must be installed in a place where it is out of the reach of people's grasp.**

## PinPoint GO TW

## Photometric Chart

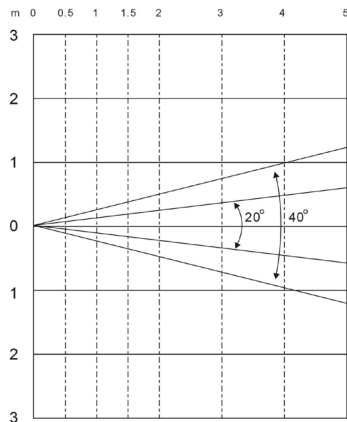

PINPOINT GO TW

|         | 0.5m   | 1m    | 2m    | 3m    | 4m   | 5m    |                   |
|---------|--------|-------|-------|-------|------|-------|-------------------|
| 20°     |        |       |       |       |      |       |                   |
| CW      | 0.185  | 0.37  | 0.74  | 1.11  | 1.48 | 1.85  | Diameter (Meters) |
| WW      | 1580   | 378   | 98    | 41.9  | 20.9 | 14.9  | LUX               |
| A       | 1018   | 267   | 76.2  | 32.2  | 19.9 | 13    | LUX               |
| CW+WW+A | 2390   | 1023  | 307   | 145.2 | 81.1 | 57.2  | LUX               |
|         | 3020   | 1219  | 302   | 145.4 | 81.8 | 50.5  | LUX               |
| 40°     |        |       |       |       |      |       |                   |
| CW      | 0.3375 | 0.675 | 1.35  | 2.025 | 2.70 | 3.375 | Diameter (Meters) |
| WW      | 1454   | 244   | 55.7  | 26.2  | 13.8 | 8.4   | LUX               |
| A       | 905    | 198   | 42.1  | 17.5  | 9.6  | 6.2   | LUX               |
| CW+WW+A | 1319   | 318   | 74    | 32.2  | 19.2 | 11.3  | LUX               |
|         | 2790   | 708   | 139.4 | 58    | 33   | 20.3  | LUX               |

## PinPoint GO TW

## Warranty

### MANUFACTURER'S LIMITED WARRANTY

- ADJ Products, LLC hereby warrants, to the original purchaser, ADJ Products, LLC products to be free of manufacturing defects in material and workmanship for a prescribed period from the date of purchase (see specific warranty period on reverse). This warranty shall be valid only if the product is purchased within the United States of America, including possessions and territories. It is the owner's responsibility to establish the date and place of purchase by acceptable evidence, at the time service is sought.
- For warranty service you must obtain a Return Authorization number (RA#) before sending back the product—please contact ADJ Products, LLC Service Department at 800-322-6337.** Send the product only to the ADJ Products, LLC factory. All shipping charges must be pre-paid. If the requested repairs or service (including parts replacement) are within the terms of this warranty, ADJ Products, LLC will pay return shipping charges only to a designated point within the United States. If the entire instrument is sent, it must be shipped in its original package. No accessories should be shipped with the product. If any accessories are shipped with the product, ADJ Products, LLC shall have no liability whatsoever for loss of or damage to any such accessories, nor for the safe return thereof.
- This warranty is void if the serial number has been altered or removed; if the product is modified in any manner which ADJ Products, LLC concludes, after inspection, affects the reliability of the product; if the product has been repaired or serviced by anyone other than the ADJ Products, LLC factory unless prior written authorization was issued to purchaser by ADJ Products, LLC; if the product is damaged because not properly maintained as set forth in the instruction manual.
- This is not a service contract, and this warranty does not include maintenance, cleaning or periodic check up. During the period specified above, ADJ Products, LLC will replace defective parts at its expense with new or refurbished parts, and will absorb all expenses for warranty service and repair labor by reason of defects in material or workmanship. The sole responsibility of ADJ Products, LLC under this warranty shall be limited to the repair of the product, or replacement thereof, including parts, at the sole discretion of ADJ Products, LLC. All products covered by this warranty were manufactured after August 15, 2012, and bear identifying marks to that effect.
- ADJ Products, LLC reserves the right to make changes in design and/or improvements upon its products without any obligation to include these changes in any products theretofore manufactured.

No warranty, whether expressed or implied, is given or made with respect to any accessory supplied with products described above. Except to the extent prohibited by applicable law, all implied warranties made by ADJ Products, LLC in connection with this product, including warranties of merchantability or fitness, are limited in duration to the warranty period set forth above. And no warranties, whether expressed or implied, including warranties of merchantability or fitness, shall apply to this product after said period has expired. The consumer's and/or Dealer's sole remedy shall be such repair or replacement as is expressly provided above; and under no circumstances shall ADJ Products, LLC be liable for any loss or damage, direct or consequential, arising out of the use of, or inability to use, this product.

This warranty is the only written warranty applicable to ADJ Products, LLC Products and supersedes all prior warranties and written descriptions of warranty terms and conditions heretofore published.

### MANUFACTURER'S LIMITED WARRANTY PERIODS:

- Lighting Products = 1-year (365 days) Limited Warranty** (Such as: Special Effect Lighting, Intelligent Lighting, UV lighting, Strobos, Fog Machines, Bubble Machines, Mirror Balls, Par Cans, Trussing, Lighting Stands etc. excluding LED and lamps)
- Laser Products = 90-Day Limited Warranty**
- L.E.D. Products = 2-year (730 days) Limited Warranty** (excluding motors, PCB boards, and power supplies, which have a 1-year (365 day Limited Warranty) and batteries which have a 180 day limited warranty).



**Model: PinPoint GO TW**SPECIFICATIONS:

|                      |   |
|----------------------|---|
| LED:                 | 1 x 5W 3-in-1 CW/WW/A LED (Cool White/Warm White/Amber) |
| Beam Angle:          | 20 Degrees<br>40 Degrees (With Frost Filter)            |
| Power:               | Rechargeable Battery & Power Adapter (DC13V 1A)         |
| Power Consumption:   | 5W<br>15W (Battery Charging)                            |
| Battery Charge Time: | 4.5 Hours (With Power Switch OFF)                       |
| Battery Life:        | 4 Hours (Full On)<br>7 Hours (Energy Saving Mode)       |
| Weight:              | 1 lbs./ 0.44 Kgs.                                       |
| Dimensions:          | 7.25"(L) x 3.5"(W) x 3.75"(H)<br>183 x 92 x 95mm        |
| Working Position:    | Any safe working position                               |
| Warranty:            | 2 Year (730 days)                                       |

**Please Note:** Specifications and improvements in the design of this unit and this manual are subject to change without any prior written notice.

ADJ Products, LLC  
6122 S. Eastern Ave. Los Angeles, CA 90040 USA  
Tel: 323-582-2650 / Fax: 323-725-6100  
Web: [www.adj.com](http://www.adj.com) / E-mail: [info@americandj.com](mailto:info@americandj.com)

A.D.J. Supply Europe B.V.  
Junostraat 2  
6468 EW Kerkrade  
Netherlands

Follow Us On:



[facebook.com/americandj](https://facebook.com/americandj)  
[twitter.com/americandj](https://twitter.com/americandj)  
[youtube.com/adjlighting](https://youtube.com/adjlighting)

[service@adjgroup.eu](mailto:service@adjgroup.eu) / [www.adj.com](http://www.adj.com)  
Tel: +31 45 546 85 00 / Fax: +31 45 546 85 99