



KRAMER ELECTRONICS LTD.

# PRELIMINARY USER MANUAL

MODEL:

**PA-150**  
70V/100V 50W Power Amplifier

---

P/N: 2900-300406 Rev 1



## PA-150 50W Power Amplifier Quick Start Guide

This guide helps you install and use your product for the first time. For more detailed information, go to <http://www.kramerav.com/manual/PA-150> to download the latest manual or scan the QR code on the left.

### Step 1: Check what's in the box

- PA-150 50W Power Amplifier
- 1 Power adapter
- Rack "ears"
- 4 Rubber feet
- 1 Quick Start sheet

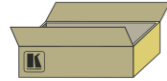

### Step 2: Install the PA-150

Attach the rubber feet and place on a table or mount the **PA-150** in a rack (using the rack "ears" supplied).

### Step 3: Connect the input and output

Always switch off the power to each device before connecting it to your **PA-150**.

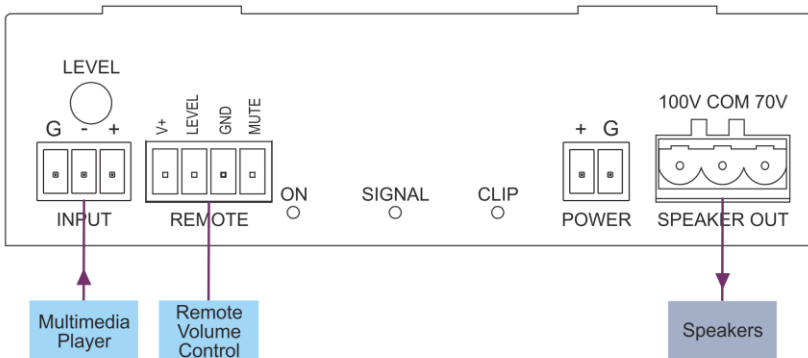

Always use Kramer high-performance cables for connecting AV equipment to the **PA-150**.

### Step 4: Connect the power

Connect the power adapter to the **PA-150** and plug it into the mains electricity



# Contents

<b>1</b>	<b>Introduction</b>	<b>1</b>
<b>2</b>	<b>Getting Started</b>	<b>2</b>
2.1	Achieving the Best Performance	2
2.2	Safety Instructions	2
2.3	Recycling Kramer Products	3
<b>3</b>	<b>Overview</b>	<b>4</b>
<b>4</b>	<b>Defining the PA-150 50W Power Amplifier</b>	<b>5</b>
<b>5</b>	<b>Connecting the PA-150</b>	<b>6</b>
5.1	Connecting the PA-150	6
5.2	Wiring the Inputs	7
5.3	Connecting Speakers	9
5.4	Connecting the Remote Volume Control	10
<b>6</b>	<b>Operating the PA-150</b>	<b>11</b>
6.1	Indicators	11
<b>7</b>	<b>Troubleshooting</b>	<b>12</b>
<b>8</b>	<b>Technical Specifications</b>	<b>13</b>

## Figures

Figure 1:	PA-150 50W Power Amplifier Rear Panel	5
Figure 2:	Connecting the PA-150 50W Power Amplifier	6
Figure 3:	Connecting a Balanced XLR Input	7
Figure 4:	Connecting a Balanced 6.5mm Phone Jack	8
Figure 5:	Connecting an unbalanced RCA Input	8
Figure 6:	Connecting an unbalanced 6.5mm Phone Jack	8
Figure 7:	Connecting One or Multiple Speakers to the PA-150 (100V)	9
Figure 8:	Connecting One or Multiple Speakers to the PA-150 (70V)	10
Figure 9:	Connecting the Remote Volume Control	10

---

# 1 Introduction

Welcome to Kramer Electronics! Since 1981, Kramer Electronics has been providing a world of unique, creative, and affordable solutions to the vast range of problems that confront the video, audio, presentation, and broadcasting professional on a daily basis. In recent years, we have redesigned and upgraded most of our line, making the best even better!

Our 1,000-plus different models now appear in 14 groups that are clearly defined by function: GROUP 1: Distribution Amplifiers; GROUP 2: Switchers and Matrix Switchers; GROUP 3: Control Systems; GROUP 4: Format/Standards Converters; GROUP 5: Range Extenders and Repeaters; GROUP 6: Specialty AV Products; GROUP 7: Scan Converters and Scalers; GROUP 8: Cables and Connectors; GROUP 9: Room Connectivity; GROUP 10: Accessories and Rack Adapters and GROUP 11: Sierra Products; GROUP 12: Digital Signage; and GROUP 13: Audio, and GROUP 14: Collaboration.

Congratulations on purchasing your Kramer **PA-150 50W Power Amplifier**, which is ideal for the following typical applications:

- Boardrooms
- Classrooms
- Hospitality
- Transportation
- Retail
- Entertainment
- Houses of worship

---

## 2 Getting Started

We recommend that you:

- Unpack the equipment carefully and save the original box and packaging materials for possible future shipment
- Review the contents of this user manual



Go to <http://www.kramerav.com/downloads/PA-150> to check for up-to-date user manuals, application programs, and to check if firmware upgrades are available (where appropriate).

### 2.1 Achieving the Best Performance

To achieve the best performance:

- Use only good quality connection cables (we recommend Kramer high-performance, high-resolution cables) to avoid interference, deterioration in signal quality due to poor matching, and elevated noise levels (often associated with low quality cables)
- Do not secure the cables in tight bundles or roll the slack into tight coils
- Avoid interference from neighboring electrical appliances that may adversely influence signal quality
- Position your Kramer **PA-150** away from moisture, excessive sunlight and dust



This equipment is to be used only inside a building. It may only be connected to other equipment that is installed inside a building.

### 2.2 Safety Instructions



**Caution:** There are no operator serviceable parts inside the unit

**Warning:** Use only the Kramer Electronics power supply that is provided with the unit

**Warning:** Disconnect the power and unplug the unit from the wall before installing

## 2.3 Recycling Kramer Products

The Waste Electrical and Electronic Equipment (WEEE) Directive 2002/96/EC aims to reduce the amount of WEEE sent for disposal to landfill or incineration by requiring it to be collected and recycled. To comply with the WEEE Directive, Kramer Electronics has made arrangements with the European Advanced Recycling Network (EARN) and will cover any costs of treatment, recycling and recovery of waste Kramer Electronics branded equipment on arrival at the EARN facility. For details of Kramer's recycling arrangements in your particular country go to our recycling pages at <http://www.kramerelectronics.com/support/recycling/>.

---

## 3 Overview

The Kramer **PA-150** is a high-performance mono, audio power amplifier for balanced signals that can output 50W of audio into 70V or 100V speaker systems.

The **PA-150 50W Power Amplifier** features:

- Output power 50 W into one channel
- 70V or 100V amplification
- Line-level, balanced input
- Input level sensitivity adjustment
- Remote volume and mute control

## 4 Defining the PA-150 50W Power Amplifier

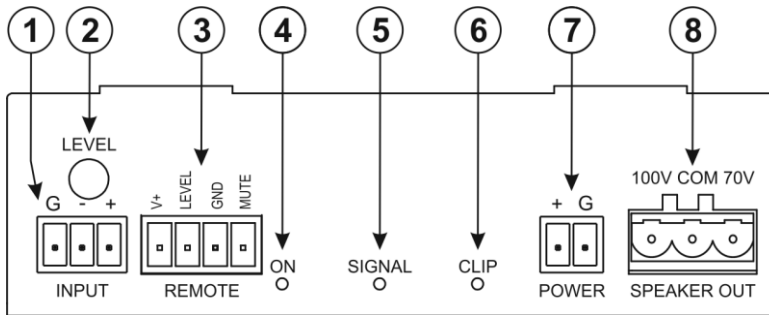

Figure 1: PA-150 50W Power Amplifier Rear Panel

#	Feature	Function
1	INPUT 3-pin Terminal Block	Connect to the line-level, balanced, stereo audio source, (for example, a media player), see <a href="#">Section 5.2.1</a> .
2	LEVEL Trimmer	Turn clockwise to increase the amplitude of the input signal; turn anticlockwise to decrease the level
3	REMOTE 4-pin Terminal Block	Connect to the remote, 10v volume control, (for example, the <b>W-LM</b> ) and mute-switch, (see <a href="#">Section 5.4</a> )
4	ON LED	Lights blue when the device receives power
5	SIGNAL LED	Lights green when there is an input signal present
6	CLIP LED	Lights red when the signal clips on the output
7	POWER 2-pin Terminal Block	Connect to the power supply provided, (see <a href="#">Section 5.4</a> )
8	SPEAKER 3-pin Terminal Block	Connect to either the 100V speaker chain or to the 70V speaker chain, (see <a href="#">Section 5.3</a> ). <b>Note:</b> Only one of the outputs can be used at a time



## 5 Connecting the PA-150

This chapter comprises the following sections:

- Connecting the **PA-150** (see [Section 5.1](#))
- Wiring the inputs (see [Section 5.2](#))
- Connecting speakers (see [Section 5.3](#))
- Connecting the Remote Volume Control (see [Section 5.4](#))

### 5.1 Connecting the PA-150



Always switch off the power to each device before connecting it to your **PA-150**. After connecting your **PA-150**, connect its power and then switch on the power to each device.

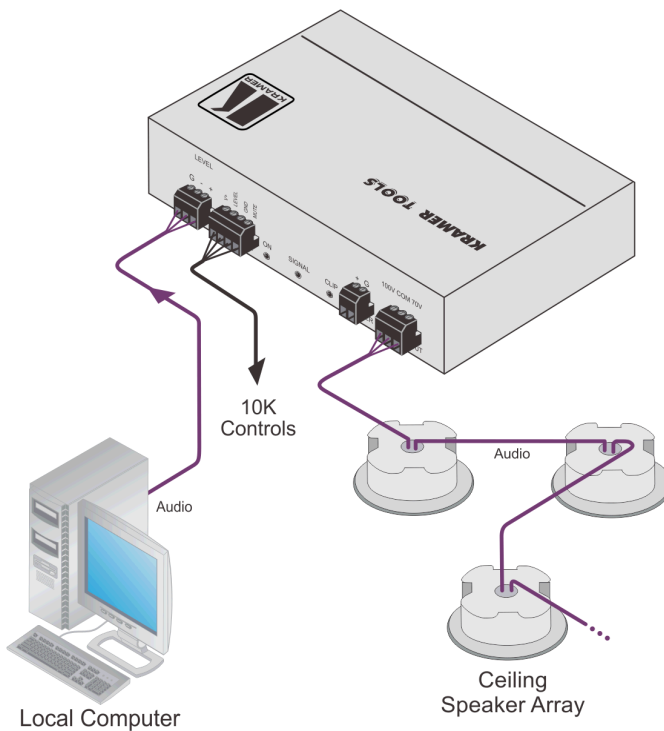

Figure 2: Connecting the PA-150 50W Power Amplifier

To connect the **PA-150** as illustrated in the example in [Figure 2](#):

1. Connect a balanced audio source, (for example, a PC) to the INPUT 3-pin terminal block.
2. Connect the speaker(s) to the SPEAKER OUT 3-pin terminal block, (see [Section 5.3](#)).
3. Connect a remote volume control, (for example, the **W-LM**) to the Remote 4-pin terminal block, (pins +V, LEVEL, and GND).
4. Connect a remote, momentary mute-switch to the Remote 4-pin terminal block, (pins Mute and GND).
5. Connect the power adapter to the **PA-150** and plug the power adapter into the mains power supply.

## 5.2 Wiring the Inputs

Your **PA-150** is provided with a 3-pin terminal block for its input connection. This connector can accept either a balanced or an unbalanced signal however, some modifications must be made for an unbalanced connection.

### 5.2.1 Wiring Balanced Inputs

When using a balanced input source and connector, you must ensure that the hot, cold, and ground pins of the connector are matched up to the +, -, and ground pins of the **PA-150** terminal block connector respectively. The following diagrams illustrate how to connect standard XLR and TRS connectors.

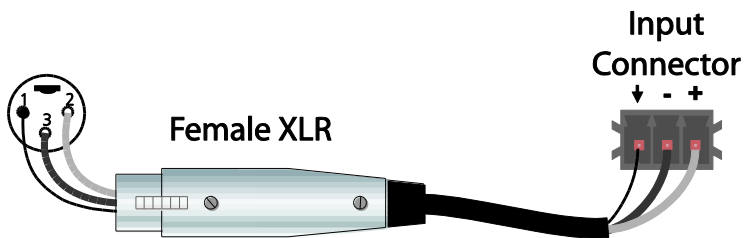

Figure 3: Connecting a Balanced XLR Input

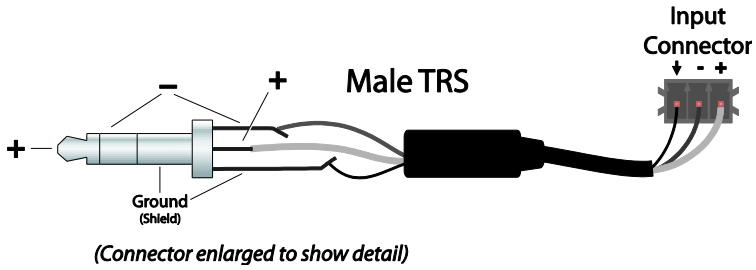

Figure 4: Connecting a Balanced 6.5mm Phone Jack

## 5.2.2 Wiring Unbalanced Inputs

When using an unbalanced input source, a jumper must be added between the negative (-) and ground terminals. The unbalanced source is connected to the positive (+) and ground terminals.

**Note:** A jumper is required for connecting an unbalanced input.

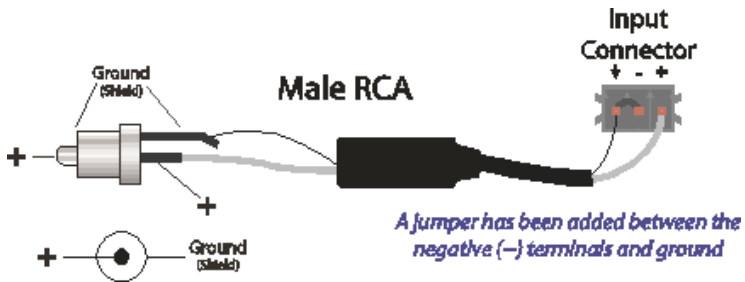

Figure 5: Connecting an unbalanced RCA Input

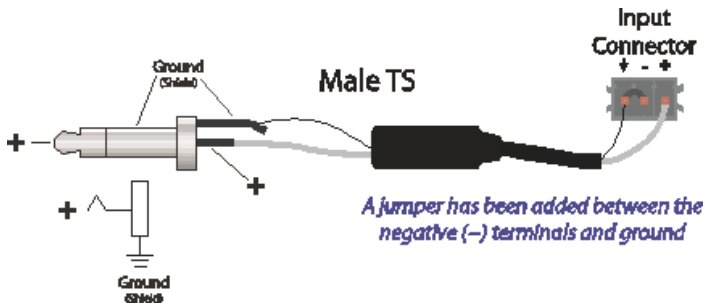

Figure 6: Connecting an unbalanced 6.5mm Phone Jack

## 5.3 Connecting Speakers

You can connect one or more 70V or 100V speakers to the **PA-150**. The following table details the cable requirements for connecting the **PA-150** to speakers.

Distance (ft.)	Wire Gauge (AWG)
Up to 500	22
500 to 1000	20
Over 1000	18

**Note:** Only one of the outputs can be used at a time.

When connecting more than one speaker they must be connected in parallel as shown in [Figure 7](#) (100V speakers) and [Figure 8](#) (70V speakers).

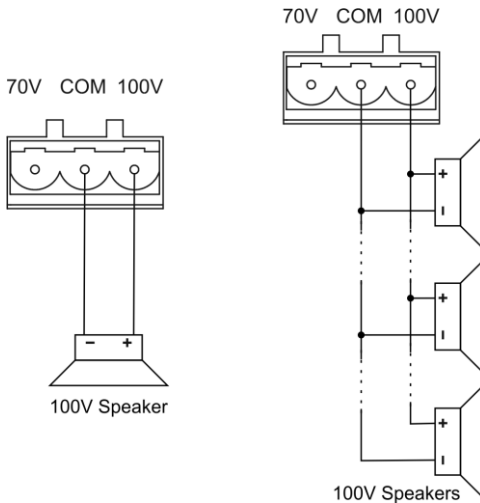

Figure 7: Connecting One or Multiple Speakers to the PA-150 (100V)

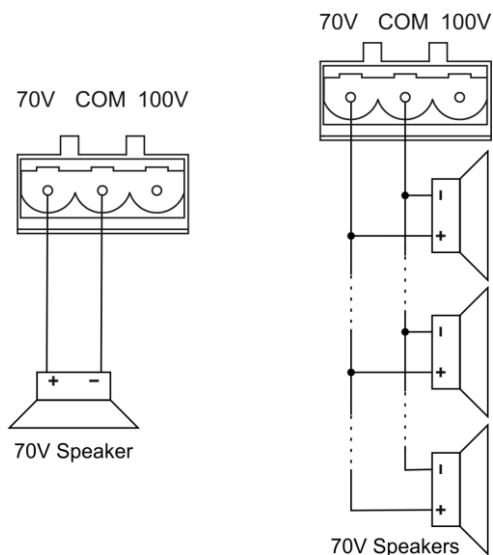

Figure 8: Connecting One or Multiple Speakers to the PA-150 (70V)

## 5.4 Connecting the Remote Volume Control

The following diagram illustrates how to connect the **W-LM** Remote Volume Control to the **PA-150**.

**Note:** The remote volume control overrides the level control on the rear of the device.

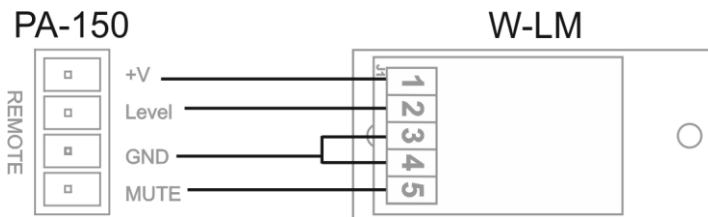

Figure 9: Connecting the Remote Volume Control

---

## 6 Operating the PA-150

### 6.1 Indicators

The following table details the LED indicators.

Label	Color	Description
SIGNAL	Green	There is an input signal present
ON	Blue	The device is receiving power
CLIP	Red	The input signal is being clipped

---

## 7 Troubleshooting

### **The PWR LED does not light.**

Check that the power adapter is plugged into a functioning outlet and that the adapter is correctly connected to the **PA-150**.

### **No output is heard from the speakers; the CLIP LED lights.**

Check that the level control and remote volume control are not turned down. Check that the input and output connections are secure. Insure that the SIG LED lights to denote a signal. If there is no signal detected, check the signal source and that the level controls are set high enough.

### **Amplifier overheats and/or shuts down.**

Check the CLIP LED on the rear of the amplifier to see if the signal is overdriving (the signal light flashes red frequently). Overdriving the amplifier for extended periods can cause a thermal shutdown.

### **Output sound is distorted or cracking.**

Check all cables for damage or loose connections and reduce the gain on the input signal at the mixer or preamp level. Replace the cables and speakers temporarily to see if this resolves the problem.

## 8 Technical Specifications

INPUTS:	1 INPUT, balanced, on a 3-pin terminal block connector
OUTPUTS:	1 OUTPUT 100V/70V on a 3-pin terminal block connector
POWER OUTPUT:	50W x 1 @ 70V/100V
FREQUENCY RESPONSE:	100Hz (0dB) to 20kHz (-3dB)
POWER BANDWIDTH:	80Hz to 30kHz ( $\pm 3$ dB)
THD+N:	<0.1%
SIGNAL to NOISE RATIO:	>80dB
REMOTE VOLUME CONTROL:	0-10V DC, 4-pin Block
INPUT SENSITIVITY:	0.5V (-3dBV)
STANDARD VOLTAGE GAIN:	150X (43dB) @70V
INPUT IMPEDANCE: (Balance/Unbalanced)	20k $\Omega$ /10k $\Omega$
INDICATOR LEDs:	On, Signal, Clip
POWER CONSUMPTION:	48V DC, 1.3A
CLASS:	D
OPERATING TEMPERATURE:	0° to +40°C (32° to 104°F)
STORAGE TEMPERATURE:	-40° to +70°C (-40° to 158°F)
HUMIDITY:	10% to 90%, RHL non-condensing
COOLING:	Convection
ENCLOSURE TYPE:	Aluminium chassis
PLENUM RATING:	UL 2043 Approved
DIMENSIONS:	15.2cm x 10.2cm x 3.2cm (6.0" x 4.0" x 1.25") W, D, H
WEIGHT:	0.46kg (1.01bs) approx.
SHIPPING WEIGHT:	1.06kg (2.34lbs) approx.
INCLUDED ACCESSORIES:	Power supply 48V DC
Specifications are subject to change without notice at <a href="http://www.kramerelectronics.com">http://www.kramerelectronics.com</a>	



## LIMITED WARRANTY

The warranty obligations of Kramer Electronics for this product are limited to the terms set forth below:

### What is Covered

This limited warranty covers defects in materials and workmanship in this product.

### What is Not Covered

This limited warranty does not cover any damage, deterioration or malfunction resulting from any alteration, modification, improper or unreasonable use or maintenance, misuse, abuse, accident, neglect, exposure to excess moisture, fire, improper packing and shipping (such claims must be presented to the carrier), lightning, power surges, or other acts of nature. This limited warranty does not cover any damage, deterioration or malfunction resulting from the installation or removal of this product from any installation, any unauthorized tampering with this product, any repairs attempted by anyone unauthorized by Kramer Electronics to make such repairs, or any other cause which does not relate directly to a defect in materials and/or workmanship of this product. This limited warranty does not cover cartons, equipment enclosures, cables or accessories used in conjunction with this product.

Without limiting any other exclusion herein, Kramer Electronics does not warrant that the product covered hereby, including, without limitation, the technology and/or integrated circuit(s) included in the product, will not become obsolete or that such items are or will remain compatible with any other product or technology with which the product may be used.

### How Long Does this Coverage Last

Seven years as of this printing; please check our Web site for the most current and accurate warranty information.

### Who is Covered

Only the original purchaser of this product is covered under this limited warranty. This limited warranty is not transferable to subsequent purchasers or owners of this product.

### What Kramer Electronics will do

Kramer Electronics will, at its sole option, provide one of the following three remedies to whatever extent it shall deem necessary to satisfy a proper claim under this limited warranty:

1. Elect to repair or facilitate the repair of any defective parts within a reasonable period of time, free of any charge for the necessary parts and labor to complete the repair and restore this product to its proper operating condition. Kramer Electronics will also pay the shipping costs necessary to return this product once the repair is complete.
2. Replace this product with a direct replacement or with a similar product deemed by Kramer Electronics to perform substantially the same function as the original product.
3. Issue a refund of the original purchase price less depreciation to be determined based on the age of the product at the time remedy is sought under this limited warranty.

### What Kramer Electronics will not do Under This Limited Warranty

If this product is returned to Kramer Electronics or the authorized dealer from which it was purchased or any other party authorized to repair Kramer Electronics products, this product must be insured during shipment, with the insurance and shipping charges prepaid by you. If this product is returned uninsured, you assume all risks of loss or damage during shipment. Kramer Electronics will not be responsible for any costs related to the removal or re-installation of this product from or into any installation. Kramer Electronics will not be responsible for any costs related to any setting up this product, any adjustment of user controls or any programming required for a specific installation of this product.

### How to Obtain a Remedy under this Limited Warranty

To obtain a remedy under this limited warranty, you must contact either the authorized Kramer Electronics reseller from whom you purchased this product or the Kramer Electronics office nearest you. For a list of authorized Kramer Electronics resellers and/or Kramer Electronics authorized service providers, please visit our web site at [www.kramerelectronics.com](http://www.kramerelectronics.com) or contact the Kramer Electronics office nearest you.

In order to pursue any remedy under this limited warranty, you must possess an original, dated receipt as proof of purchase from an authorized Kramer Electronics reseller. If this product is returned under this limited warranty, a return authorization number, obtained from Kramer Electronics, will be required. You may also be directed to an authorized reseller or a person authorized by Kramer Electronics to repair the product.

If it is decided that this product should be returned directly to Kramer Electronics, this product should be properly packed, preferably in the original carton, for shipping. Cartons not bearing a return authorization number will be refused.

### Limitation on Liability

THE MAXIMUM LIABILITY OF KRAMER ELECTRONICS UNDER THIS LIMITED WARRANTY SHALL NOT EXCEED THE ACTUAL PURCHASE PRICE PAID FOR THE PRODUCT. TO THE MAXIMUM EXTENT PERMITTED BY LAW, KRAMER ELECTRONICS IS NOT RESPONSIBLE FOR DIRECT, SPECIAL, INCIDENTAL OR CONSEQUENTIAL DAMAGES RESULTING FROM ANY BREACH OF WARRANTY OR CONDITION, OR UNDER ANY OTHER LEGAL THEORY. Some countries, districts or states do not allow the exclusion or limitation of relief, special, incidental, consequential or indirect damages, or the limitation of liability to specified amounts, so the above limitations or exclusions may not apply to you.

### Exclusive Remedy

TO THE MAXIMUM EXTENT PERMITTED BY LAW, THIS LIMITED WARRANTY AND THE REMEDIES SET FORTH ABOVE ARE EXCLUSIVE AND IN LIEU OF ALL OTHER WARRANTIES, REMEDIES AND CONDITIONS, WHETHER ORAL OR WRITTEN, EXPRESS OR IMPLIED. TO THE MAXIMUM EXTENT PERMITTED BY LAW, KRAMER ELECTRONICS SPECIFICALLY DISCLAIMS ANY AND ALL IMPLIED WARRANTIES, INCLUDING, WITHOUT LIMITATION, WARRANTIES OF MERCHANTABILITY AND FITNESS FOR A PARTICULAR PURPOSE. IF KRAMER ELECTRONICS CANNOT LAWFULLY DISCLAIM OR EXCLUDE IMPLIED WARRANTIES UNDER APPLICABLE LAW, THEN ALL IMPLIED WARRANTIES COVERING THIS PRODUCT, INCLUDING WARRANTIES OF MERCHANTABILITY AND FITNESS FOR A PARTICULAR PURPOSE, SHALL APPLY TO THIS PRODUCT AS PROVIDED UNDER APPLICABLE LAW.

IF ANY PRODUCT TO WHICH THIS LIMITED WARRANTY APPLIES IS A "CONSUMER PRODUCT" UNDER THE MAGNUSON-MOSS WARRANTY ACT (15 U.S.C.A. §2301, ET SEQ.) OR OTHER APPLICABLE LAW, THE FOREGOING DISCLAIMER OF IMPLIED WARRANTIES SHALL NOT APPLY TO YOU, AND ALL IMPLIED WARRANTIES ON THIS PRODUCT, INCLUDING WARRANTIES OF MERCHANTABILITY AND FITNESS FOR THE PARTICULAR PURPOSE, SHALL APPLY AS PROVIDED UNDER APPLICABLE LAW.

### Other Conditions

This limited warranty gives you specific legal rights, and you may have other rights which vary from country to country or state to state.

This limited warranty is void if (i) the label bearing the serial number of this product has been removed or defaced, (ii) the product is not distributed by Kramer Electronics or (iii) this product is not purchased from an authorized Kramer Electronics reseller. If you are unsure whether a reseller is an authorized Kramer Electronics reseller, please visit our Web site at [www.kramerelectronics.com](http://www.kramerelectronics.com) or contact a Kramer Electronics office from the list at the end of this document.

Your rights under this limited warranty are not diminished if you do not complete and return the product registration form or complete and submit the online product registration form. Kramer Electronics thanks you for purchasing a Kramer Electronics product. We hope it will give you years of satisfaction.



For the latest information on our products and a list of Kramer distributors, visit our Web site where updates to this user manual may be found.

**We welcome your questions, comments, and feedback.**

Web site: [www.kramerelectronics.com](http://www.kramerelectronics.com)

E-mail: [info@kramerel.com](mailto:info@kramerel.com)

CE



**SAFETY WARNING**

Disconnect the unit from the power supply before opening and servicing

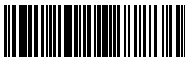

P/N: 2900-300406



Rev: 1