



# THE TRIODE BOARD™

*Control and Protection  
for your  
Triode RF Power Amplifier*



## *All the hard work done!*

- Protects your triodes
- Grid and anode current metering
- LED status indicators
- Warm-up timer
- Adjustable regulated cathode bias
- TX/RX switching and relay supplies
- Simple wiring to one PC board
- Easy to build – clear 'how-to' instructions in this User Manual.



## *Versatile!*

Use with one or two tubes  
including 3-500Z, 3CX800, 8877/3CX1500,  
GS35b/GS31b, G17b, TH308, YD1336...





## WARNING

*These notes are intended for users who have sufficient experience to work safely with high-voltage circuits.*

*Use at your own risk! We cannot accept responsibility for any damage or injury.*

**DANGER - AC mains voltage and high DC voltages!**

### REVISION NOTES

AN-2 Issue No	Triode Board Issue No	Revision Details
1.0, September 1999	2.4 (first production boards)	Revised after extensive pre-release testing.
1.1, October 1999	2.4	R24 changed to 3K3; note about HV metering.
1.2, April 2000	2.4	Minor updates and typos, change of Internet and WWW addresses.
1.3, January 2002	2.4	Minor updates to component list.
1.4, April 2002	2.4	Updated components list, and part numbers in schematics and main text
1.5, April 2002	2.4	Reformatted to A4; new US distributor; included AN-5 as Appendix 1

#### 'European' Component Markings

'R' in resistor values means  $\Omega$ , e.g.  
15R = 15 $\Omega$ , 3K3 = 3.3k $\Omega$ , 1M0 =  
1.0M $\Omega$  etc.

For better readability, the multiplier  
letter replaces the decimal point,  
so 0R33 = 0.33 $\Omega$ , 1K0 = 1.0k $\Omega$  etc.

The same applies to small  
capacitors, e.g. 4n7 = 4.7nF  
(nanofarads) = 4,700pF.

# CONTENTS

<b>1. Features</b> .....	<b>4</b>
<b>2. Introduction</b> .....	<b>5</b>
2.1 What You Get.....	5
2.2 What You'll Need.....	5
2.3 Choosing Configuration Options .....	5
<b>3. Triode Amplifier Control and Protection</b> .....	<b>6</b>
3.1 Grid and Anode Current Metering .....	6
3.2 Meter and Surge Protection.....	6
3.3 Grid Current Protection .....	9
3.4 Cathode Bias .....	10
3.5 TX/RX Switching .....	10
3.6 24V Relay Option .....	11
3.7 PTT Options .....	11
3.8 Warm-up Timer Options.....	12
3.9 RFI Protection.....	12
<b>4. Using Your Tubes and Meters</b> .....	<b>12</b>
4.1 Which Tube – or Tubes?.....	12
4.2 Choosing and Using Meters .....	13
<b>5. Building the <i>Triode Board</i></b> .....	<b>15</b>
5.1 Mounting the Board .....	15
5.2 Board Modifications .....	15
5.3 Assembling the Board .....	15
5.4 Building the LED Array .....	17
5.5 Building the HV Divider.....	17
<b>6. Off-line Testing</b> .....	<b>19</b>
6.1 Meters.....	19
6.2 Cathode Bias Adjustment.....	21
6.3 Control Logic and Alarm Settings.....	21
<b>7. Interconnections</b> .....	<b>24</b>
7.1 Mains Power Control .....	24
7.2 HV Control and Safety.....	25
7.3 CHASSIS GROUND Connection .....	25
7.4 RFI Suppression.....	25
<b>8. Power-Up</b> .....	<b>26</b>
8.1 First Switch-on.....	26
8.2 Cathode Bias Adjustment.....	26
8.3 RF Testing.....	26
<b>9. Updates and Product Support</b> .....	<b>27</b>
<b>Schematics</b> .....	<b>28–32</b>
<b>Parts List</b> .....	<b>33</b>
<b>Appendix 1 – Higher Cathode Bias</b> .....	<b>37</b>

## 1. Features

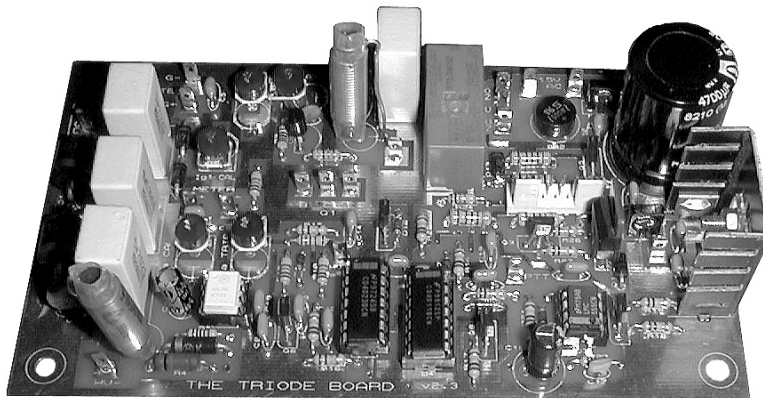

### All on one PC board – simplifies external wiring

- Cathode bias supply: adjustable 3-30V, precision regulated up to 2.5A or more.
- Grid and anode current metering, with meter protection.
- Status output to four LEDs.
- Relay TX/RX switching.
- Warm-up timer – also controls High Voltage.
- Grid current and HV monitored – protects sensitive grids from overdrive.
- Anode current monitored for surge protection – also controls your High Voltage supply.
- 12/24V DC supply for external relays (uses external mains transformer).
- Highest RFI immunity – high-level CMOS logic, extensive RF filtering and groundplane shielding.
- Quality double-sided PC board measures 5.7in x 3.3in.
- Designed for 'key down forever' reliability.

## 2. Introduction

### 2.1 What You Get

To give you the best possible value for money, we do not supply expensive 'off-board' components such as meters, transformers and large heatsinks. You can probably find these components much more cheaply as surplus.

The full **Triode Board** kit includes:

1. The PC board, double-sided with plated through holes and printed component locations.
2. All the on-board components – premium quality for reliability. To cover almost all possible combinations of tubes and meters, the kit includes a range of resistors of various values.
3. Power transistor (Q1) and mounting kit (but not heatsink).
4. Push-on tags for board connectors.
5. Complete schematics and this *User Manual*.

The 'bare board' option is the **Triode Board** with this same *User Manual*.

### 2.2 What You'll Need

Most of these additional components are easier to buy surplus than at new prices, so we didn't include them in the kit. See Section 5 for more details about these components.

1. **RESET** switch: SPST momentary push-button (low-voltage).
2. **STATUS** LEDs: two red, one green, one yellow or blue, all ordinary 20mA types. See Section 5.4 for details of how to build the LED array.
3. Heatsink for Q1: 4in x 3in x 1in, or equivalent (2°C/W or less). For low bias voltages and lower-power tubes, you can mount Q1 on a cool area of the chassis.
4. Metal mounting pillars and hardware for the PC board.
5. M1 (grid current): 0–100µA moving-coil meter recommended. See Section 4.2 for details of meter selection and recommended scaling.
6. M2 (anode current): 0–100µA moving-coil meter recommended. See Section 4.2 for details of meter selection and recommended scaling.
7. Transformer: for 12V relays, use 15V AC at up to 1A; for 24V relays, use 20V AC at up to 1A. This transformer winding must not be connected to the transformer winding for the tube heater.
8. HV divider, to provide a 12–15V 'HV present' signal (and also act as a backup bleeder chain). See Section 5.5 for details of construction.

You will also need a few temporary components and a multimeter for the setting-up procedures.

### 2.3 Choosing Configuration Options

Every power amplifier is different, so there are many possible options for cathode bias voltages, metering etc. Sections 3 and 4 give full details.

### 3. Triode Amplifier Control and Protection

Please don't start to build the *Triode Board* until you have read all of Sections 3–5.

The *Triode Board* is designed only for grounded-grid triode RF power amplifiers.

Direct grounding of the grid to the chassis is mandatory in amplifiers above 30MHz, and it is the most common option for HF amplifiers also.

The *Triode Board* will function with HF amplifiers that have the grid raised above chassis ground, but this feature must **not** be used for grid current metering.

#### 3.1 Grid and Anode Current Metering

Grid and anode current metering is achieved in the normal way, by connecting the meters between the chassis, cathode and HV-minus (B-minus) rails. Figure 1 shows how this works.

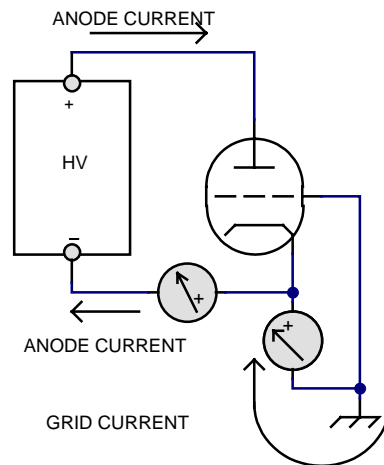

Figure 1: Grid and anode current metering

Notice that only grid current flows through the grid current meter, and only anode current flows through the anode current meter. (It's hard to believe, but at least one amplifier manufacturer fails to get this right!)

#### 3.2 Meter and Surge Protection

Any power amplifier needs several levels of protection: for your tubes, meters, HV transformer – and above all, YOURSELF.

##### 3.2.1 Anode Current Surges

Nobody knows why sudden anode current surges happen – they're over too quickly! Reasons suggested include sporadic releases of gas into the vacuum inside the tube, microscopic 'whiskers' of metal inside the tube, stray hairs or insects outside the tube, "spurious renegade photoelectrons" (no kidding), line voltage surges, parasitic oscillations, intermittent antenna connections, cosmic rays...

The important thing is that sudden anode current surges **do** happen, and many people have learned what damage they can do. **All this damage is preventable!**

The worst surges are arcs or flashovers. These can occur either inside or outside of the vacuum envelope of the tube, and lead to a near-short circuit from HV+ to chassis. As

shown in Figure 2 below, the entire arc return current flows through the meters for grid current and anode current. This can destroy the meters unless they are protected.

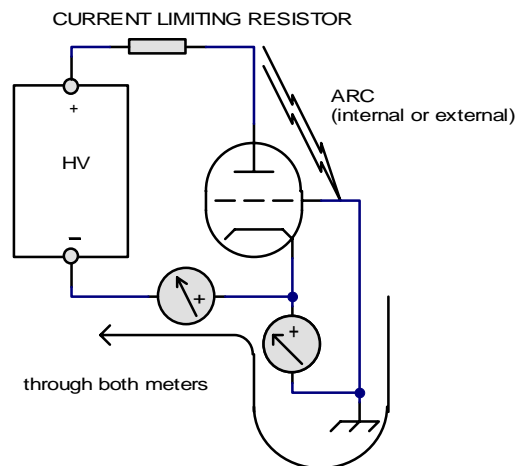

Figure 2: Arc or flashover from HV+ to chassis can destroy grid and anode current meters.

There are three basic kinds of protection against anode current surges:

- **Use a current limiting resistor in the HV+ line**, to limit the maximum possible surge current. See Section 7.2.3 for details. **YOU MUST USE THIS VITAL SAFETY COMPONENT!**
- **Use protective diodes around the meters**, both to protect the meters and to clamp the HV-minus rail close to chassis potential. The **Triode Board** does this.
- **Switch off the HV transformer** to minimize the follow-on energy after the arc begins. The **Triode Board** allows you to do this, and it can save greatly on interruptions in operation due to blown fuses. Arcs often do not recur, and in many cases you can resume operation by simply pressing the **RESET** button, which brings up the HV again.

### 3.2.2 Meter Scaling and Protection

Grid and anode current meter ranges vary widely between different amplifier designs, according to the type and number of tubes involved. However, the protection requirements are always the same.

Figure 3 (next page) shows two basic ways of metering 500mA of anode current. Figure 3a uses a meter with a low-resistance shunt, while Figure 3b measures the voltage drop across a higher-value metering resistor.

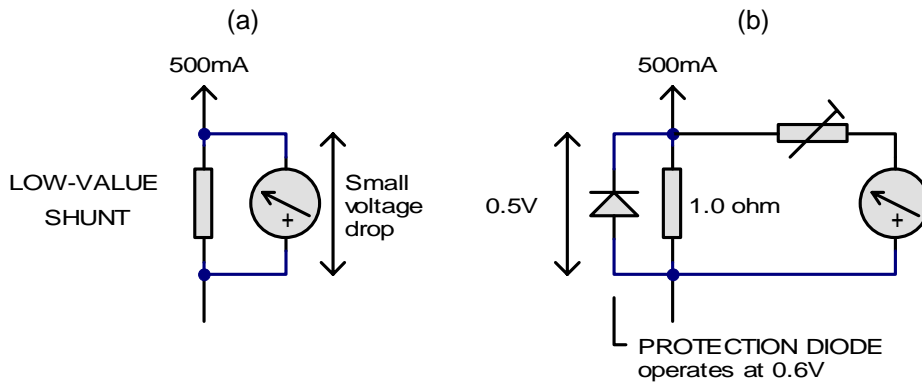

Figure 3: Two ways to measure 500mA anode current.  
 (a) Low-resistance shunt – a ‘protection’ diode would be useless.  
 (b) 0.5V metering resistor with protection diode and adjustable range.

Problems with the low-resistance shunt method (Figure 3a):

- ✘ 1. The shunt resistor depends on the full-scale reading required, and also on the internal resistance of the meter.
- ✘ 2. The shunt resistor is always an unusual low value, and it needs to be hand-made from resistance wire.
- ✘ 3. It is difficult to adjust the value of the shunt to make the meter read correctly.
- 💣 4. Protection **diodes are ineffective with low-resistance meters and shunts** because the voltage drop is usually too low. The diodes do not begin to operate until there is enough current to develop 0.6V, which may be enough to **destroy the meter**.

The **Triode Board** uses the circuit of Figure 3b, which overcomes all four of these objections:

- ✓ 5. The shunt resistor depends only on the full-scale reading required.
- ✓ 6. Standard fixed resistor values can be used
- ✓ 7. The trimpot allows you to adjust the full-scale reading precisely, and it takes care of all tolerance variations.
- 🔒 8. If the full-scale voltage drop across the shunt resistor is close to 0.5V, **protection diodes will be highly effective** because they start to conduct heavily at about 0.6V.

The schematic on page 30 shows the metering circuits in the **Triode Board** for grid and anode currents. Section 4 explains how to choose meters and metering resistors for your particular amplifier.

Page 30 also shows how the meter protection in the **Triode Board** works. Diodes D1 and D2 divert anode current surges safely around the meters, and also clamp the HV-minus rail close to chassis potential. The surge is finally stopped when the HV supply is interrupted by either the sensing circuit (see below) or a blown fuse.

D1 and D2 need to have a high surge current rating – ordinary 1A rectifier diodes are marginal, so this design uses big 6A diodes with a surge current rating of 400A. An anode current surge flows in the opposite direction to normal grid current, so diodes D3 and D4 are included to also protect the meter M1 against excessive forward grid current.



### 3.2.3 Anode Current Protection

This section gives more details of the anode current protection circuit. See the schematics on pages 30 and 31.

In order not to interfere with anode current metering, the protection circuit senses anode current using a separate resistor R3. The voltage drop across R3 makes current flow through the opto-coupler U1A. This causes an approximately equal current to flow through U1B, RV5 and R24, and this controls the voltage on pin 13 of U5C. If the anode current increases above a certain value, it triggers the flip-flop U5C-U4A. RV5 determines the level of anode current at which this happens.

When the flip-flop is triggered, pin 10 of U5C goes 'high', Q4 is cut off, and the HV CTRL line goes 'low'. If this line is connected to a mains contactor in the primary of the HV transformer, as shown on page 28, then it will switch off the HV within a few milliseconds and light the red **ANODE** alarm LED\*.

To reset the flip-flop, press the **RESET** button and allow the HV to come up again. If the problem that caused the arc has cleared, and no fuses have blown in the HV supply, you can continue operating immediately.

## 3.3 Grid Current Protection

### 3.3.1 Excessive Grid Current

Excessive grid current can damage triodes very quickly. It can be caused by any combination of high RF drive, incorrect loading and/or low HV. The **Triode Board** monitors for high grid current and also for low HV. If either condition is detected, the PTT is disabled and the **GRID/HV** alarm LED lights.

### 3.3.2 Grid Current Sensing

See the schematics on pages 30 and 31.

Grid current is detected across R1 (page 30). In order to operate the sensing circuit (details below) the maximum voltage drop across R1 needs to be about 0.8V. Therefore the over-current protection for the meter M1 requires two silicon diodes in series, D3 and D4, to prevent incorrect grid current reading when the meter is close to full scale.

A voltage proportional to the grid current is sampled by RV3 and generates base current into Q6 (page 31). This causes collector current to flow through R13, which pulls pin 4 of U5B down from the +12V line. At a level of grid current set by RV3, this will trigger the flip-flop U5A-U5B, which disables the PTT, releases the TX/TX relay K1, lights the red **GRID/HV** alarm LED and turns off the green **READY** LED.

The **GRID/HV** alarm is automatically reset when you release the PTT button, or when the transceiver's VOX delay times out. This will allow you to resume operating if the high grid current was only intermittent. If the grid current is still high when you attempt to transmit again, the circuit will trigger again to protect the tube.

### 3.3.3 Low HV Sensing

The HV OK input measures a divided-down sample from the anode high voltage rail. (The HV divider is separate from the **Triode Board** for general safety reasons. See Section 5.5 and page 29 for construction details.)

At normal levels of HV, the divider should be designed to give a sample voltage in the range +8–12V at the HV OK input. If the HV is low, so that the sample voltage falls below about +6V, it will trigger the flip-flop U5A-U5B (page 31). This disables the PTT, releases

---

\* We strongly recommend that you use the anode current protection relay in the HV transformer primary. The rest of these instructions assume that anode current protection **is** present.

the TX/TX relay K1, lights the red **GRID/HV** alarm LED and turns off the green **READY** LED.

The **GRID/HV** alarm is automatically reset when you release the PTT button, or when the transceiver's VOX delay times out. This will allow you to resume operating if the low HV condition was only intermittent, e.g. a brief drop in AC mains voltage. If the HV is still low, the circuit will trigger again to protect the tube.

#### **WARNING**

**Damage to the grid may occur if you apply RF drive while the amplifier is in a fault condition.**

### **3.4 Cathode Bias**

For low intermodulation distortion, the cathode bias needs to be as constant as possible. Also the bias needs to be adjustable to set each individual tube to the manufacturer's recommended no-drive idling current.

Conventional high power zener diodes have several disadvantages: they are not adjustable; their voltage tends to rise significantly with anode current; and diodes large enough to survive anode current surges can be quite expensive. Other solutions such as forward-biased rectifier diodes give even poorer bias voltage regulation.

The **Triode Board** uses a true constant-voltage bias regulator which is fully adjustable (page 30) so you can set the idling current exactly as the manufacturer recommends. The circuit is taken from the data sheet for the industry-standard TL431 'adjustable zener' (U2). An inexpensive Darlington power transistor Q1 handles the power dissipation, and is rated to survive major current surges. The Varistor VDR1 (V24ZA50) provides further circuit protection.

The **Triode Board** cathode bias circuit is normally adjustable in the range from 3 to 27V, which suits most tubes including the 3-500Z, 3CX800 and 8877. For tubes such as the GS35b and GS31b, which can require up to 30V bias (or more at high anode voltages) cut the thin track under the resistor marked HI-B and insert a 1.5k $\Omega$  resistor. Change VDR1 to two V24ZA50 in series.

The component kit contains two V24ZA50 VDRs. For the high-bias option, connect these in series, on the board. For the normal bias range, use one VDR on the board and install the second VDR in the RF deck, between the cathode DC connection and chassis ground.

For even higher bias, see **Application Note 5** at the rear of this manual.

### **3.5 TX/RX Switching**

TX/RX changeover of the **Triode Board** is controlled via the PTT line, which switches the bias relay K1. You will also need to control the coaxial changeover relays – probably one at the input of the amplifier as well as one at the output.

You will also need to control the coaxial changeover relays – probably one at the input of the amplifier as well as one at the output. Spare changeover contacts on K1 can be wired as you need – these are marked NC (closed on RX), NO (open on RX) and C (common).

At this time the **Triode Board** does not provide sequenced TX/RX changeover on-board, but it is compatible with external sequencers. Many transceivers provide a few milliseconds delay between PTT operation and the start of RF output, which may allow you to switch the coax relays safely from the spare contacts of K1. The **Triode Board** will support full break-in changeover

---

\* If you do not wish to use Low HV sensing, connect the HV OK input permanently to the +12V DC output from the voltage regulator U6. The rest of these instructions assume that Low HV sensing is used.

(QSK) if you replace K1 with an electronic bias switch and provide the necessary sequenced timing.

### 3.6 24V Relay Option

The **Triode Board** includes its own rectifier and voltage regulator for the +12V DC rail. If you are using 12V DC relays, use the **Triode Board** as supplied, with a transformer input of 15V AC to the two AC IN terminals.

If you are using 24V DC relays, you will need to make the following simple changes:

1. Change the transformer to 20V AC.
2. Change R28 to 10K.
3. Change R27 to a 15V 0.25-0.5W zener (e.g. BZX79-C15 or 1N4109 etc.) with its cathode stripe nearest to Q4.
4. Change R30 and R32 to 1K 1-2W.
5. Change K1 to RTE24024 (Schrack or Potter & Brumfield – see Parts List).
6. Underneath the board, cut the track marked **12V** where it narrows, and link across the gap marked **24V** as shown below.

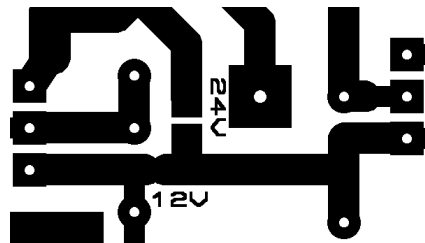

Figure 4: Modifications for 24V relays (underside view)

7. The 12V regulator U6 will not need a heatsink.

### 3.7 PTT Options

When the PTT line is grounded, the current drawn from the transceiver is about 10 $\mu$ A. When the PTT line is un-grounded, the open-circuit voltage is regulated at +12V. This is compatible with the PTT output of almost every known transceiver.

For transceivers that provide +12V output on transmit and a short to ground on receive, follow these conversion instructions:

1. On the underside of the board beneath U4, cut the thinned track between pin 4 and pin 11 (Figure 5).
2. Join the link between pins 6 and 12, by bridging the small gap at pin 12.

Figure 5: Modifications for +12V PTT (underside view)

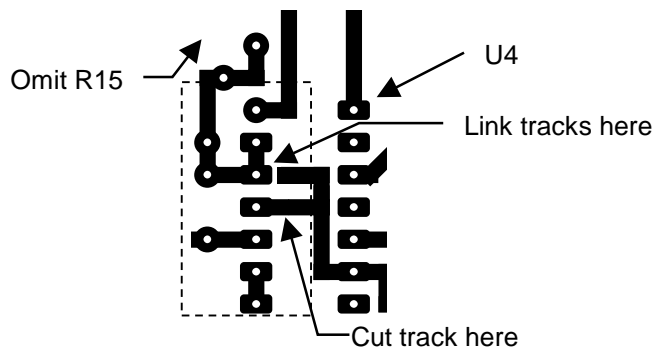

3. Do not insert R15.

### 3.8 Warm-up Timer Options

The warm-up timer is a standard 555 circuit (page 31). The values of R21 and C18 shown give a time delay of about 3 minutes, which is suitable for most indirectly-heated cathodes.

For tubes such as the 3-500Z with a directly heated filament, you should reduce the warm-up delay to a few seconds, e.g. by changing C18 to 10 $\mu$ F and R21 to 150–220k $\Omega$ . (**Note:** even with ‘instant-heat’ tubes, you still need the warm-up timer because the circuit will not initialize correctly without it.)

### 3.9 RFI Protection

The unshielded layout of many amateur power amplifiers can lead to large stray RF voltages on the wiring. This applies particularly to amplifiers for HF and for 50MHz, which often do not have totally shielded and bypassed RF compartments.

**The Triode Board** is designed for high immunity against RF interference (RFI). The PC board has both top-side and bottom-side groundplanes wherever possible, and the board can be grounded to the chassis at all four corners. The design uses high-level CMOS logic for optimum RF immunity, and critical external connections are protected by RF chokes and bypass capacitors. There are many RF bypass capacitors on the board, with provision to add even more bypassing if needed.

**The Triode Board** has been tested in amplifiers from 1.8MHz to 1.3GHz, in some extreme RFI situations, but we cannot guarantee RFI immunity in all situations. We will be pleased to help if you find any difficulties (contact details in Section 9).

## 4. Using Your Tubes and Meters

You can use the **Triode Board** with a wide range of tubes, and also a wide range of panel meters for grid current and anode current.

### 4.1 Which Tube – or Tubes?

Your choice of tube or tubes affects several components.

R1 is the grid current metering resistor. The value is chosen to give approximately 0.7–0.8V drop at full-scale grid current. R2 is the anode current metering resistor, and its value is chosen to give approximately 0.5V drop at full-scale anode current. The nearest standard resistor values are used.

R3 is the anode current sensing resistor. For one large tube or two smaller tubes, use 2.2 $\Omega$  for R3. This allows RV5 to set the anode current trip in the range 0.9–1.4A. For one smaller tube, use 3.3 $\Omega$  for a 0.6–0.9A current limit.

The table below shows typical full-scale values for grid and anode current meters using various combinations of popular tubes, and also the values of R3 and cathode bias voltage.

Tube(s)	I <sub>g</sub> max	R1	I <sub>a</sub> max	R2	R3	Bias (typical)
One 8877	200mA	3R3	1.5A	0R33	2R2	8–12V
One GS31/35b	400mA	2R2	1.5A	0R33	2R2	24–30V
Two 3CX800	100mA	6R8	1.5A	0R33	2R2	5.1–8V
One 3CX800	50mA	15R	1.0A	0R47	3R3	5.1–8V
Two 3-500Z	350 or 400mA	2R2	1.5A	0R33	2R2	9V
One 3-500Z	150 or 200mA	4R7	0.75A	1R0	3R3	9V

Industry-standard 5W end-mount resistors are recommended for R1–R3, and are supplied in the kit. The kit includes nine 5W resistors of various values, enough for any of the above options (you will have six resistors left over). You can also use normal axial-lead power resistors, mounted vertically.

## 4.2 Choosing and Using Meters

You can use a wide variety of meters for grid and anode current, and the calibration resistors on the **Triode Board** will make them read correctly.

It always looks good to use matched meters on your front panel, and this ‘universal’ calibration method allows you to use an identical matched pair, even though they are measuring very different currents.

There are two basic requirements for meters:

1. The full-scale deflection current should be substantially lower than the current you are measuring.
2. The full-scale voltage drop inside the meter **must** be less than 0.5V. The table below shows the maximum allowable internal resistance of the meter (measure with a multimeter)

The preset variable resistors RV1 and RV2 are used to adjust the meters to exactly the correct full-scale reading, as described later in Section 6. The best value depends on the meter sensitivity – choose from the table below.

Meter full-scale	Max internal resistance ( $\Omega$ )	RV1 ( $\Omega$ )	RV2 ( $\Omega$ )
100 $\mu$ A	5k	5k	10k or 5k
1mA	500	500	1k or 500
10mA	50	50	100

The kit is supplied with two 500 $\Omega$  trimpots and two 5k $\Omega$  trimpots, so you should use the table to make the best choices for RV1 and RV2 (you will have two trimpots left over).

### 4.2.1 Example

You have a pair of 0–1mA meters that you’d like to use with the **Triode Board**.

1. Check the internal resistance with a multimeter. Let’s say the value is about 400 $\Omega$ . This is less than the limit of 500 $\Omega$  for a 1mA meter in the table above, so these meters are OK to use.
2. RV1 can be a 500 $\Omega$  trimpot (the value supplied with the kit).
3. RV2 can be a 1k $\Omega$  trimpot, but a 500 $\Omega$  trimpot (the value supplied with the kit) will probably be OK and would be easier to adjust.

For intermediate-value meters such as 500 $\mu$ A, adjust all values in the table proportionally. As the current goes down, all the resistance values go up.

### 4.2.2 Higher-current Meters?

What if you have some 100mA meters, or higher? The bad news is that I don’t recommend using these without modification. The good news is that if you open up the meters, you’ll probably find that they contain an internal shunt resistance between the terminals. If you remove this shunt, the basic meter movement will probably be something like 0–1mA or 0–10mA which should be OK for the **Triode Board**.

### 4.2.3 Re-scaling Meters

You probably won’t find meters with the correct scale values, so you will need to alter the scale. There are various options – starting with the easiest:

- Do nothing – ‘re-scale’ the meters in your head, whenever you look at them. This is definitely the easiest, but your friends in the contest group may find it confusing!
- Change the units – for example, you can convert a 0–1mA meter to read 0–1A by carefully erasing the ‘m’ in ‘mA’.
- Change by factors of 10 – either erase some zeros on the scale, or add more zeros using matching rub-on numbers.
- Keep the existing scale arc, but change all the numbers.
- Re-draw the complete meter face using a CAD package, and glue the printout on to the existing scale plate. This is a lot more effort, but the results look very professional (Figure 6).

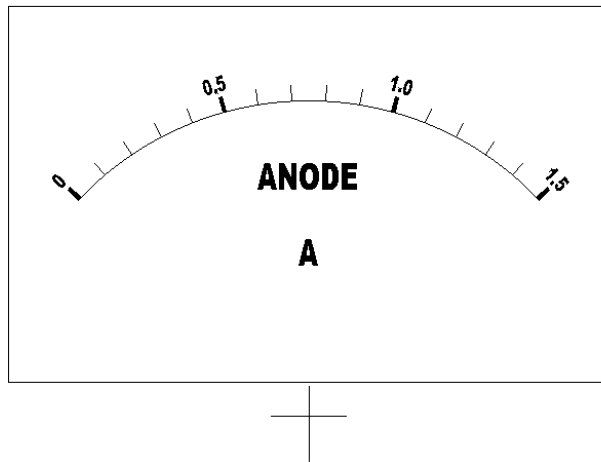

Figure 6: A meter scale re-drawn using AutoSketch.

See <http://mywebpages.comcast.net/tonne/> for WB6BLD's excellent free program that designs the scale for you!

## 5. Building the *Triode Board*

Please don't start to build the *Triode Board* until you have read all of Sections 3–5.

### 5.1 *Mounting the Board*

Use the bare PC board as a template to mark the chassis fixing holes (hole centers 5.2in x 2.8in).

Fix the board to the chassis on 0.5-in (12mm) pillars. Metal pillars are only necessary as an extra RFI precaution (see Section 7.4). If you use metal pillars, take care to avoid shorting to the tracks beneath the board.

### 5.2 *Board Modifications*

If you wish to use the 24V relay option (Section 3.6) or to make the +12V PTT modification (Section 3.7) cut and link the necessary tracks on the board now, before assembling any components.

### 5.3 *Assembling the Board*

1. Fit the blade connector tags to the board **first**. Support the board on a firm, flat sheet of expanded polystyrene. Hold each tag with long-nosed pliers, and tap it gently into place with a very small hammer. Solder to the PC pad – let some solder run through the plated-through hole to the top side, to make the anchor even stronger.

In the connection pads for Q1, you can fit either blade terminals provided or use a three-way 0.2in-pitch connector (not supplied with kit).

2. Identify the components – see below.

#### COMPONENT MARKINGS

**Check the markings on each component BEFORE you solder it in place...  
make that a DOUBLE-check!**

##### Resistors

Some resistors are marked with the familiar three-band value code, e.g. 10K $\Omega$  is brown-black-orange...

**BUT** many resistors in the kit may be marked with a four-band value code: 1st digit, 2nd digit, 3rd digit (always black), number of zeroes. In this coding, a 10K $\Omega$  resistor is brown-black-black-**RED** – so take care! If in doubt, measure the resistors with a multimeter.

The upright 5W resistors are marked with the 'European' value codes, e.g. 3R3 means 3.3 $\Omega$ , 0R56 means 0.56 $\Omega$  etc.

## Trimpots

These may have a two-digit marking: 1st digit is value, 2nd is number of zeroes:

500Ω	<b>52</b>
1KΩ	<b>13</b>
10KΩ	<b>14</b>

## Ceramic capacitors

The 1nF capacitors are marked **102** (read the code as “1, 0 and 2 more zeroes”, i.e. 1,000pF or 1nF). Similarly the 10nF capacitors are marked **103**, and 0.1μF (100nF) capacitors are marked **104**.

## Diodes

The small glass diodes are all 1N4148s. All other diodes have their part number clearly marked. Various alternatives may be supplied for the larger diodes and BR1.

## Transistors and ICs

Note the transistor outlines printed on the board – these are correct for the devices supplied in the kit, but they may not be correct if you make substitutions! Observe static precautions when handling transistors.

Q1 is mounted separately on its own heatsink, following the E-C-B connections printed on the board. The pinout of Q1 is shown in the schematic on page 30.

Take care to install all the DIL sockets with the index notch in the correct positions (U1, U4 and U5 ‘up’, U3 ‘down’).

## Heatsinks

You must provide the large off-board heatsink for Q1, as detailed in Chapter 2, or use the chassis. You must also provide nuts and screws to fix the TO-220 transistor tabs to all of the heatsinks. For Q1 there is a plastic bush to insulate the bolt from the transistor tab, and also a special insulating, heat-conducting washer. Do not use heatsink compound with this washer, but do make sure that the heatsink is flat, with no burrs around the mounting hole.

For the small on-board heatsink for U6, use heatsink compound with a nut and bolt. No insulation is required.

3. Use the table on page 12 to identify which values of 5W resistors you will need for R1, R2 and R3. Also use the table on page 13 to identify which values of trimpots RV1 and RV2 you will need to suit your tube(s) and meters. (The kit includes a range of resistor and trimpot values to cover a wide range of possible tubes and meters. When you have made your choices, there will be some components left over.)
4. Assemble the components to the board. Observe polarity of diodes, IC sockets and ICs. Use a fine-tip soldering iron – watch out for missed pads and solder bridges. Take care not to flood empty plated-through holes with solder – it can be difficult to remove.
5. Connections for all alarm LEDs and the **RESET** button are brought out to an 8-way header. You may fit a standard 0.1in-pitch connector (not supplied with the kit), or simply solder in wires.
6. When you have finished all wiring, remove flux residues, solder balls etc. from both sides of the finished board. Use denatured alcohol or isopropyl alcohol and an old toothbrush to clean the board. Rinse well and allow to dry.
7. **Check the board very carefully** for incorrect components, missed connections, dry joints or solder bridges. Use a magnifier!



## 5.4 Building the LED Array

The layout for the array of LED indicators and the **RESET** switch will depend on your individual front panel design.

A good way to build the LED array is to use 0.1in stripboard (Veroboard etc.). Mount the LEDs on the stripboard, and also use a scrap piece of board as a drilling template for the front panel. If you have used an 8-way ribbon cable to connect to the **Triode Board**, terminate the cable on to 8 copper strips (wire 3 is unused). Then connect the strips to your desired layout of LEDs using wire links. Use two additional flexible wires to connect the **RESET** switch.

Figure 7 shows an example of a front-panel layout, and labels for the LED indicators. From the top, the LED colors should be: **TX** green or blue, **READY** green, **GRID/HV** and **ANODE** both red.

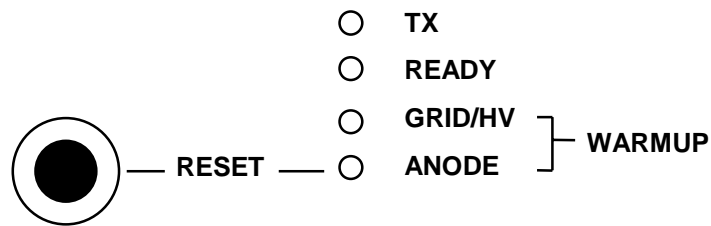

Figure 7: A front-panel layout for the LED array and **RESET** button.

## 5.5 Building the HV Divider

The HV divider should be close to the RF deck, so that the divider sees the same high voltage that the triode sees\*. It should be designed to produce +8–12V at the HV OK input to the **Triode Board**. The GRID/HV alarm will trigger if the voltage at the HV OK input drops below about +6V.

The 1M $\Omega$  resistors should be 0.5W metal film or metal glaze components, each rated to withstand at least 350V. To avoid voltage breakdown, use at least four 1M $\Omega$  resistors per kilovolt of HV, off-load:

HV	No. of resistors	HV	No. of resistors
2000V	8	3000V	12
2500V	10	3500V	14

and so on...

The schematic of the HV divider is shown in Figure 8 and also in the **Interconnections** diagram on page 29 (R106A-Z, R107, R108).

\* It makes no sense to put the HV divider in a separate HV power supply, because it will indicate "HV OK" even when the HV feed to the tube is totally disconnected !

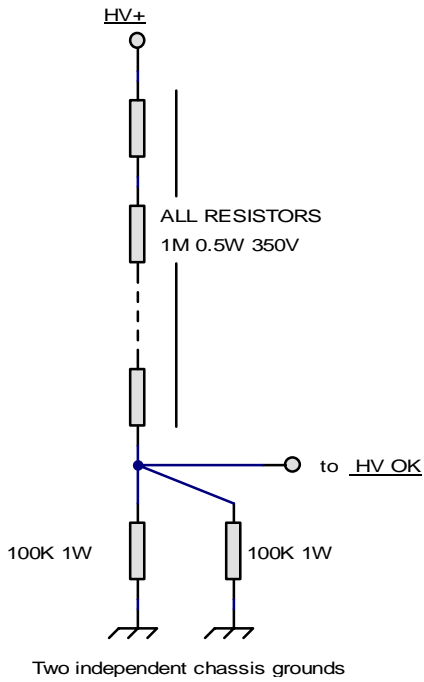

Figure 8: HV divider circuit.

The two 100kΩ 1W resistors are selected to provide about +8–12V at the HV OK input to the **Triode Board**, under normal operating conditions (if you have used the correct number of 1MΩ resistors for the off-load operating voltage).

**Note:** the two 100kΩ resistors are **safety components**, designed to make sure that there is no possibility of the chassis ground return failing – because that would let HV into the low-voltage circuit. To make doubly sure, use two completely independent high-quality chassis ground connections.

Build the resistor chain on un-clad fibreglass PC board, close to the RF deck, and provide good insulation for the high voltages involved.

The HV OK output from the divider is also a good point to connect a voltmeter which is calibrated to measure the high voltage. If you are doing this, the voltage at the HV OK output **must** be less than 12V – otherwise the HV meter will read incorrectly (due to the protection diode D6).

## 6. Off-line Testing

### WARNING

Follow the instructions in this section, and test all the functions of the *Triode Board* BEFORE you install it in the amplifier.

It's much simpler and safer to do it this way!

1. Remove any socketed ICs. Disconnect Q1. Disconnect the feed from the HV divider to HV OK. Disconnect the LED indicator board.
2. Connect the mains transformer for the relay supply to the two AC IN terminals. Apply mains power to the transformer.

### WARNING

Do not apply 115/230V AC mains directly to the *Triode Board* !

If you are using the normal 12V relay option, the transformer should be 15V AC. Check that about +20V appears at the +UNREG terminal, and that +12V DC appears at the output of U6 (marked **12V** under the board).

If you are using the 24V relay option, the transformer should be 20V AC. Check that about +28V appears at the +UNREG terminal, and that +12V DC appears at the output of U6 (marked **12V** under the board, on the U6 side of where you cut the track).

3. Switch off and disconnect from the mains. Fix any problems with the 12/24V DC supply before you go any further.

## 6.1 Meters

### 6.1.1 Grid current meter calibration (M1)

1. Connect your grid current meter to the G+ and G- terminals (observe correct polarity). Turn RV2 fully clockwise.
2. Connect a 100 $\Omega$  2W variable resistor to an external +12V DC supply, and in series with this connect an accurate current meter to the A+ terminal (see Figure 9, next page). This will allow you to pass a known current through the grid meter shunt R1. Alternatively you can use a variable voltage/current power supply.

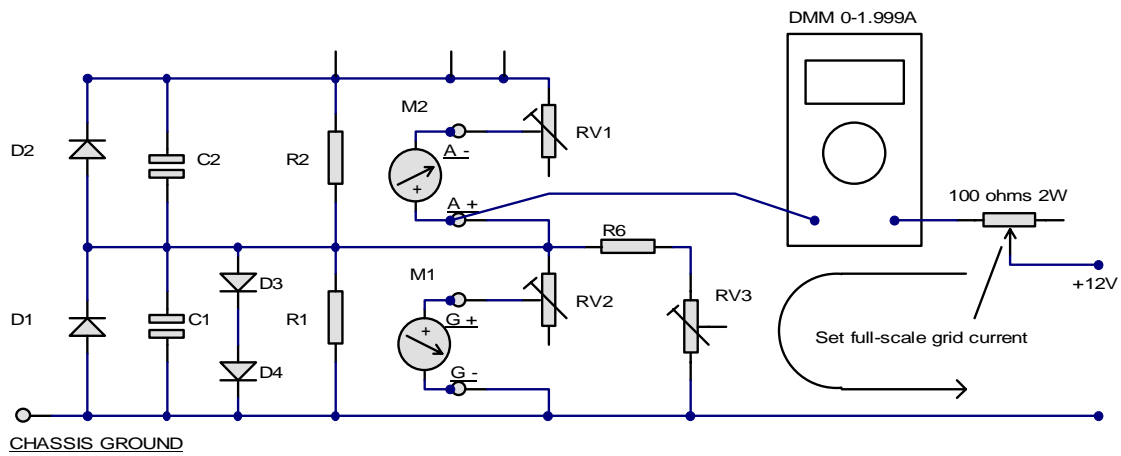

Figure 9: Calibration setup for grid current meter. Alternatively you can use a variable voltage/current power supply.

3. Apply power and adjust the current to a known value. Then adjust RV2 to give the same reading on your meter scale.
4. This completes the calibration of the grid current meter. Switch off and disconnect from the mains. Disconnect your test setup.

### 6.1.2 Anode current meter calibration (M2)

This procedure requires an external 'floating' power supply capable of delivering typically 0.5–1.5 ampere, e.g. a mains supply or a small lead-acid battery.

1. Connect your anode current meter to the A+ and A– terminals (observe correct polarity). Turn RV1 fully clockwise.

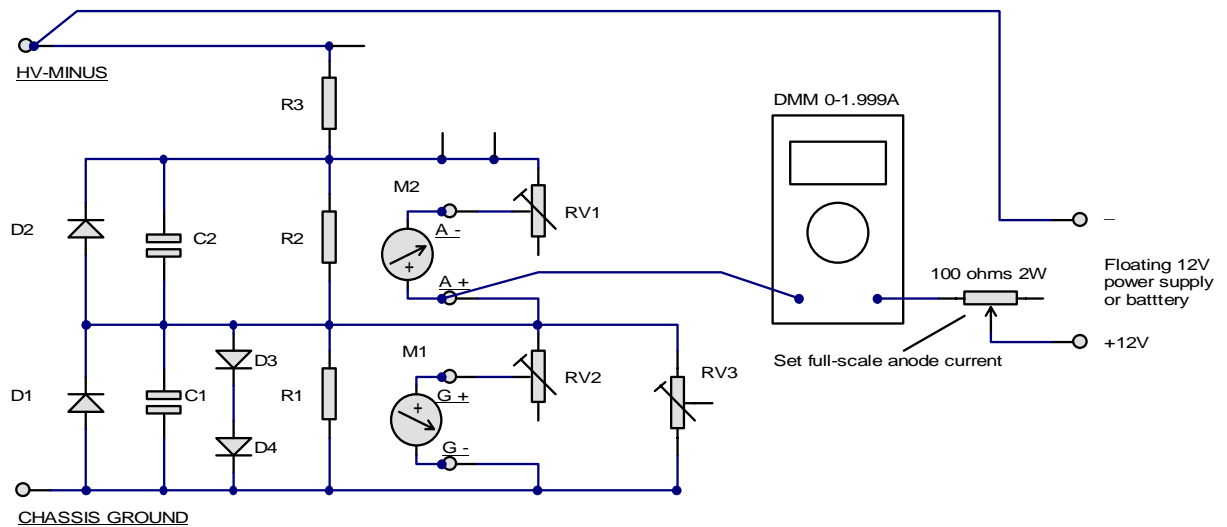

Figure 10: Calibration setup for anode current meter. Alternatively you can use a variable voltage/current power supply.

2. Connect a 100Ω 2W variable resistor to the positive terminal of your power supply, and in series with this connect an accurate current meter to the A+ terminal (see Figure 10 above). Connect the negative terminal of your power supply to the HV-MINUS terminal. This will allow you to pass a known current through the anode meter shunt R2 (and also the anode current trip resistor R3 – see Section 6.3.3 later).
3. Apply power and adjust the current to a known value. Then adjust RV1 to give the same reading on your meter scale.
4. This completes the calibration of the anode current meter. Switch off power. Disconnect your test setup.

## 6.2 Cathode Bias Adjustment

1. Connect Q1 (observe correct connections). To apply current through the cathode bias regulator, connect a 47Ω 1W resistor from the + terminal of an external power supply to the E terminal of Q1 (see Figure 11). Connect the – terminal of the power supply to the C terminal of Q1.
2. Connect an accurate voltmeter between the C and E terminals of Q1, as shown in Figure 11.

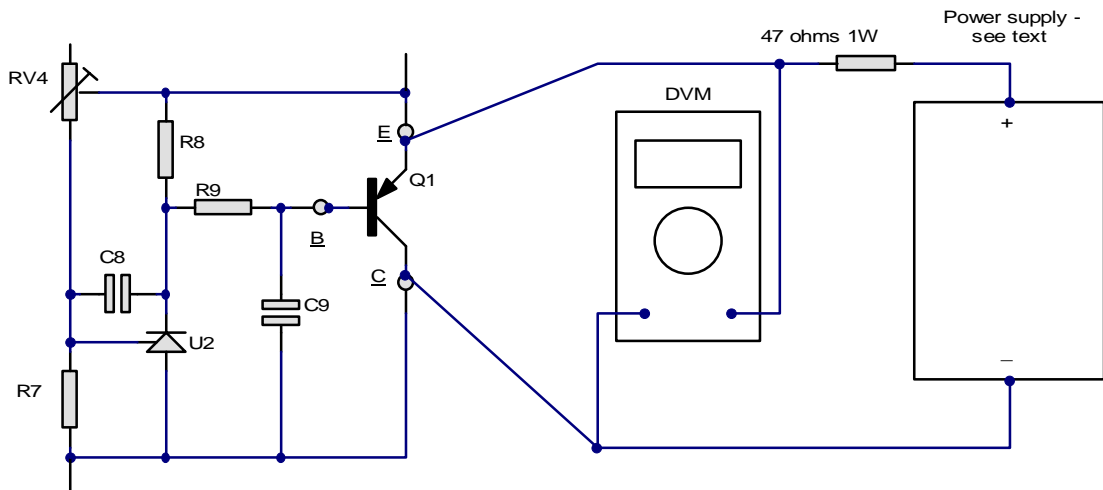

Figure 11: Cathode bias test setup

3. The voltage available from the power supply must be greater than the required bias voltage. Apply power, and check that RV4 will continuously adjust the bias voltage across the desired range. Set RV4 to the approximate bias voltage for the tube you intend to use.

If you have a variable voltage/current supply, check that the cathode bias regulator will hold the regulated voltage constant over a current range from about 50mA up to at least 2A. (If you see even a very small variation, it will probably be due to voltage drops in the interconnecting leads – not the voltage regulator itself.)

4. Switch off and disconnect from the mains. Disconnect your test setup.

This completes the meter calibration and checkout of the cathode bias circuit.

## 6.3 Control Logic and Alarm Settings

### 6.3.1 Control Logic Checkout

1. Connect a 47kΩ resistor in parallel with R21 under the board. This will shorten the warm-up time delay during testing. (Ignore this step if you have already configured R21 and C18 for a short delay.)
2. If you are using the PTT line in its standard ground-to-TX configuration, ignore this instruction completely. If you have modified the PTT switching for +12V TX, then ground the PTT terminal now, and reverse all future instructions to “ground” and “un-ground” it.
3. Insert all socketed ICs (observe correct orientation) and connect the LED board and **RESET** switch.
4. Apply AC power from the transformer to the two AC IN terminals. The red **ANODE** and **GRID/HV** LEDs should both come on. After about 5 seconds the **ANODE** LED should go out when the warm-up timer completes.

5. Connect the +UNREG terminal to HV OK to simulate a signal from the HV divider. The **GRID/HV** LED should go out and the **READY** LED should come on. The HV CTRL terminal should be at almost +12V (or about +24V if you chose the 24V relay option).
6. Ground the PTT terminal. The **TX** LED should come on and you should hear the relay K1 operate. Check for correct operation as you un-ground and ground the PTT terminal.
7. While the PTT terminal is grounded, disconnect HV OK from +UNREG to simulate a low HV fault. The **TX** and **READY** LEDs should both go out, K1 should release and the **GRID/HV** alarm LED should come on. Check that PTT is locked out until the HV OK voltage is restored and also the PTT line has been un-grounded.
8. Switch off. Re-connect the link from HV OK to +UNREG, and leave it connected until this checkout procedure is complete.

### 6.3.2 Grid Current Alarm

1. Reconnect the temporary grid current setup as shown in Figure 9. Set RV3 to mid-travel.
2. Apply power and let the warm-up timer complete. Only the green **READY** LED should be lit.
3. Inject a simulated grid current and set it at the level where you want the circuit to trigger (full-scale on the meter is usually a good point).
4. Turn RV3 slowly clockwise until the red **GRID/HV** LED lights and the green **READY** LED goes out. Reduce the test current, and the light should go out. Repeat the adjustments until the circuit triggers exactly where you want it to.
5. Remove power and remove the temporary wiring.

### 6.3.3 Anode Current Alarm

1. Reconnect the temporary anode current setup as shown in Figure 10. Set RV5 fully counter-clockwise.
2. Apply power and let the warm-up timer complete. Only the green **READY** LED should be lit.
3. Inject current and set it at the level where you want the circuit to trigger (again, full-scale on the meter is usually a good point).
4. Turn RV5 slowly clockwise until the red **ANODE** LED lights, the green **READY** LED goes out and the HV CTRL output drops to zero. Reduce the test current, and the status should stay the same until you press the **RESET** button. Repeat the adjustments until the alarm operates exactly where you want it to (remember that you need to press **RESET** each time).

If the alarm operates at too low a current, change R24 to 2.2k $\Omega$ .

5. Remove power and remove the temporary wiring.

### 6.3.4 Warm-up Timer

1. If you are using the normal value of 1.0M $\Omega$  for R21, and had connected a temporary 47k $\Omega$  resistor in parallel with R21 to shorten the warm-up time, then remove that resistor now.
2. Apply power, and check that the warm-up timer takes approximately 3 minutes to complete (with R21 = 1.0M $\Omega$ , C18 = 100 $\mu$ F).

**This completes all the off-line tests. The *Triode Board* will now be calibrated and ready for use.**

## 7. Interconnections

The **Interconnections** diagrams on pages 28 and 29 show all the connections to the **Triode Board**, and some recommended circuits for the rest of your amplifier.

**Note:** part numbers on the Interconnection diagrams start at 101 to distinguish them from part numbers on the **Triode Board**.

### 7.1 Mains Power Control

The mains power control components discussed below are shown in the **Interconnections 1** diagram on page 28.

#### 7.1.1 HV Power Control

The **HV CTRL** terminal provides +12V DC to a mains power relay in your HV supply (+24V DC if you made the 24V relay modification in Section 3.6). This control voltage is only available after the warm-up timer has completed, so no HV is applied during the warm-up period.

If the anode current protection circuit triggers for any reason, the HV control voltage is removed in less than 5 milliseconds.

**HV control is an important safety feature. We strongly recommend that you use it.**

To use this feature you must install a 12V (or 24V) DC-operated relay K101 to interrupt the mains supply to the HV transformer. Make sure that the relay is capable of interrupting the maximum overload current of the transformer – with a very large safety margin. An ‘electric motor’ relay or contactor is a good choice.

The Omron G7L-1A-T SPNO 30A relay has proved very effective, and is available in both 12V DC and 24V DC versions from many European and US suppliers. There are also many other 24V high-current relays and contactors.

#### 7.1.2 Step-Start Circuit

A step-start circuit is strongly recommended, and the **Interconnections 1** diagram on page 28 shows a circuit suitable for 220-240V mains.

#### 7.1.3 Blower Control

To prolong tube life you should allow plenty of time for the tube to cool down after transmitting. The **Interconnections 1** diagram on page 28 shows a method to allow the blower to continue for a few minutes after the mains power has been switched off.

SW102 is a thermal switch that is cemented on to the side of R101, which is connected across the 220-240V mains feed to the heaters and HV. R101 is intended to run hot, and SW102 will close when its temperature reaches 60°C, which happens after a few minutes of normal operation.

When you switch off the amplifier using SW101, the thermal switch SW102 remains closed until it cools down, and thus keeps the blower running for a few minutes more. (Thanks to GW3NWS for this idea.)



## 7.2 HV Control and Safety

### 7.2.1 HV Mains Control

See Section 7.1.1.

### 7.2.2 HV-minus Rail

For additional safety, the HV-minus rail should be connected to chassis ground by a large, reliable 1k $\Omega$  resistor, close to the bottom of the capacitor stack. This resistor is shown as R105 in the **Interconnections 2** diagram on page 29. **Note:** if R105 is less than 200 $\Omega$ ,  $\tau$  will affect the accuracy of the anode current meter.

The **Triode Board** already provides safety diodes for the HV-minus rail. Do **not** connect any additional safety diodes between the HV-minus rail and chassis – they are not necessary, and also they may prevent the meters from reading correctly.

### 7.2.3 Safety Resistor in the HV+ Rail

This resistor is R104 in the **Interconnections 2** diagram on page 29. It limits the maximum possible anode current in any sudden surge condition.

Eimac recommends limiting the maximum possible surge current to 40A or less, for transmitting tube up to about 1500W anode dissipation. This implies that the resistor should be about 25 $\Omega$  per kilovolt of HV. In practice, 50 $\Omega$  is a typical value. (Some circuits show 10 $\Omega$  or 20 $\Omega$  but I feel this may be too low for anode supplies of 3kV or more.)

The resistor needs to be physically large, both to handle the power dissipation in normal use, and to avoid flashovers along the resistor body in the event of an arc. A 50 $\Omega$  resistor in a 1A supply will be dissipating 50W key-down, so this is really a minimum acceptable rating. Always choose a longer-bodied resistor in preference to a short, stubby one of the same rating.

## 7.3 CHASSIS GROUND Connection

### WARNING

The **CHASSIS GROUND** connection is vital for safety!  
Do not rely on metal mounting pillars for safe grounding.

Connect the **CHASSIS GROUND** terminal using heavy wire – it may need to carry up to 40A in an anode current surge. Ground the wire to a large, reliable ground lug, firmly bolted to the chassis.

## 7.4 RFI Suppression

The **Interconnections 2** diagram on page 29 shows some extra RFI suppression components that you might need to fit outside the Triode Board itself. C102 and C103 can be connected directly across the two meters, if needed.

If RFI is particularly severe, you should consider the possibilities for better RF screening, and also the use of shielded wire for meter connections etc. Keep all connecting wires close to the chassis or panel, and as far away as possible from RF components such as the tube and the RF input and output circuits.

## 8. Power-Up

### CAUTION

When you install the *Triode Board* in your amplifier, take care not to change any of the calibration adjustments that you have already made to RV1–RV5.

### 8.1 First Switch-on

Since you have already tested the *Triode Board* off-line before you built it into the amplifier (Section 6), there should be no surprises when you first switch the whole amplifier on.

#### What to expect:

1. When you first switch on, the blower should start, the heaters should begin to warm up, and the warm-up timer will start. Only the two red **ANODE** and **GRID/HV** LEDs will be lit.
2. When the warm-up period is complete, the **ANODE** LED will go out, the HV\_CTRL line will come up and the HV mains relay will close. (At this moment, the **GRID/HV** LED will still be lit because there is no HV yet.)
3. A few moments later, when the step-start has operated and the HV comes up, the **GRID/HV** LED will go out and the green **READY** LED will come on.
4. The two red LEDs will not light again unless there is a fault.

The amplifier is now in its standby condition with the tube cut off.

### 8.2 Cathode Bias Adjustment

1. Set the transceiver to SSB, with VOX switched off and MIC gain set to zero.
2. Press the PTT. The yellow or blue **TX** LED will light and the anode current will rise to its zero-signal level.
3. Although you pre-set the approximate cathode bias voltage in Section 6.2, the current will probably not be quite correct. Use RV4 to adjust the zero-signal cathode current to the manufacturer's recommended value.
4. Release the PTT.

This completes the cathode bias adjustment.

### 8.3 RF Testing

RF testing of power amplifiers is outside the scope of this Application Note, but whichever way you do it, the *Triode Board* will protect the tube(s).

## 9. Updates and Product Support

Updates and further Application Notes will be provided on the World Wide Web and by e-mail.

- G3SEK: <http://www.ifwtech.co.uk/g3sek/boards/>

**If you purchased the *Triode Board* from Tom's Tubes in the USA, please e-mail [boards@ifwtech.co.uk](mailto:boards@ifwtech.co.uk) to be included on the list for future e-mail updates.**

For advice on details not covered by these notes, you can e-mail G3SEK direct:

- [boards@ifwtech.co.uk](mailto:boards@ifwtech.co.uk)

# Triode Board – Interconnections 1

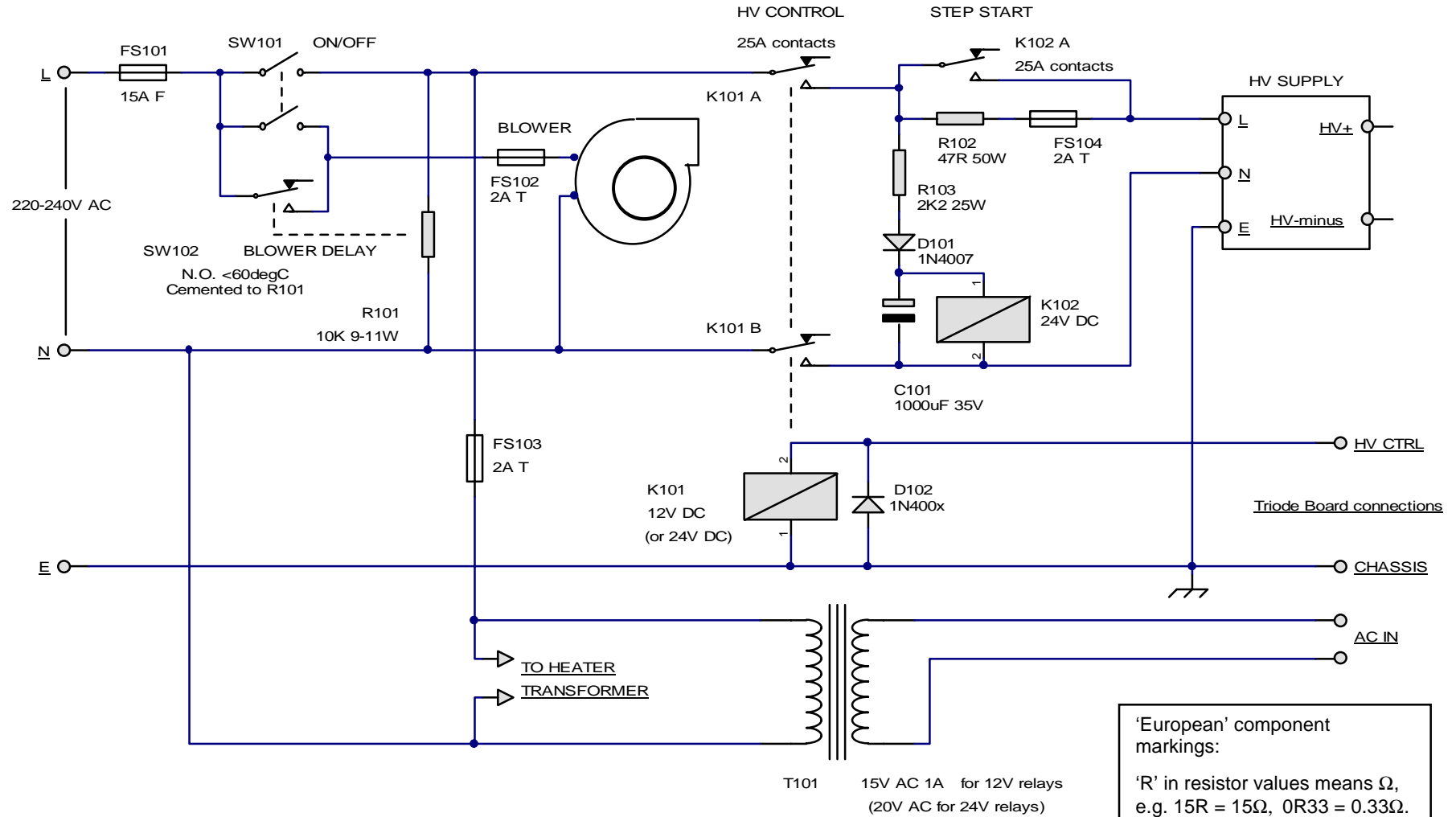



# Triode Board Schematic – Sheet 1

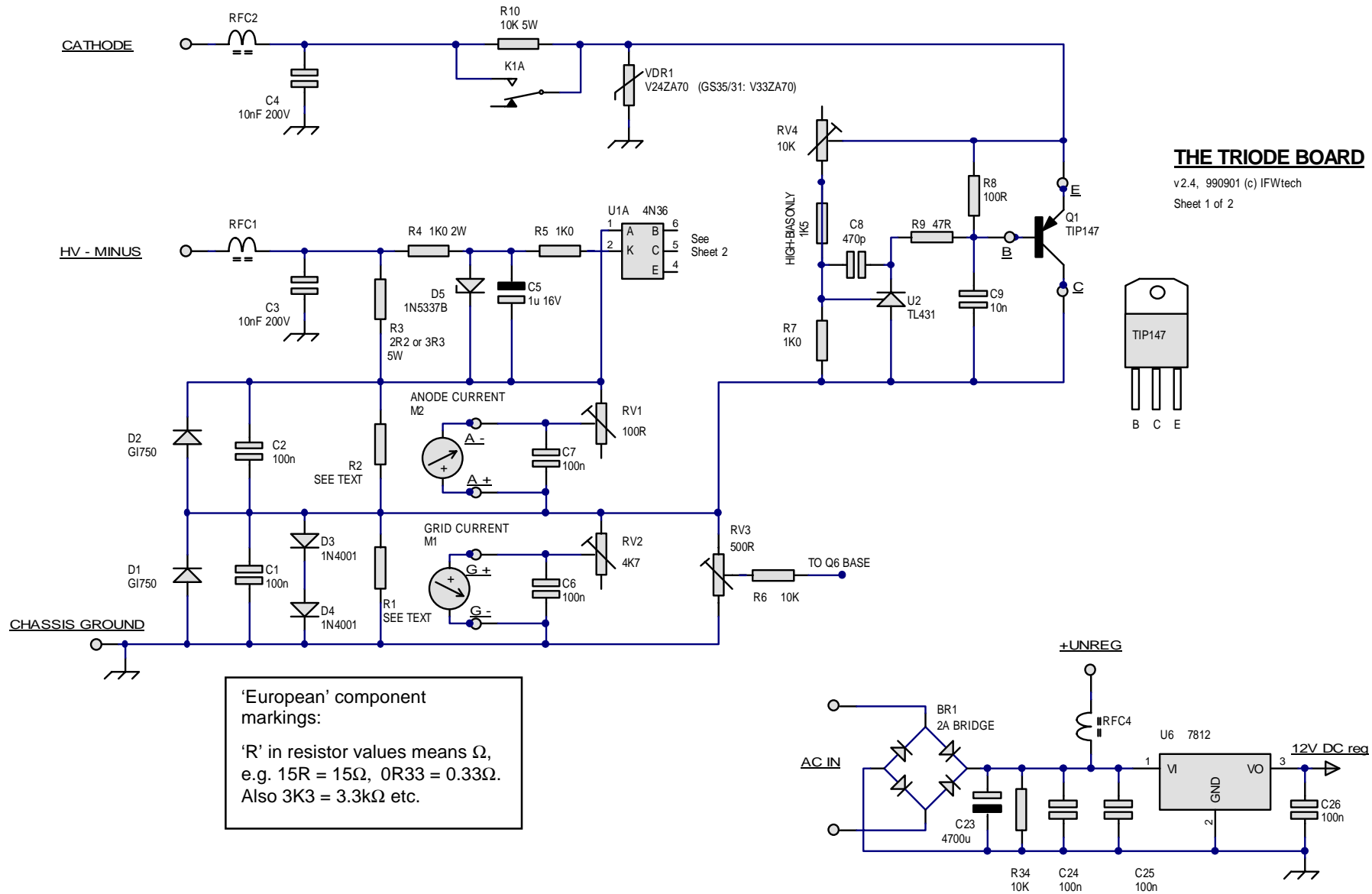

## THE TRIODE BOARD

v2.4, 990901 (c) IFWtech  
Sheet 1 of 2

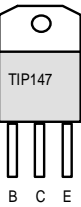

'European' component markings:  
 'R' in resistor values means  $\Omega$ ,  
 e.g. 15R = 15 $\Omega$ , 0R33 = 0.33 $\Omega$ .  
 Also 3K3 = 3.3k $\Omega$  etc.

# Triode Board Schematic – Sheet 2

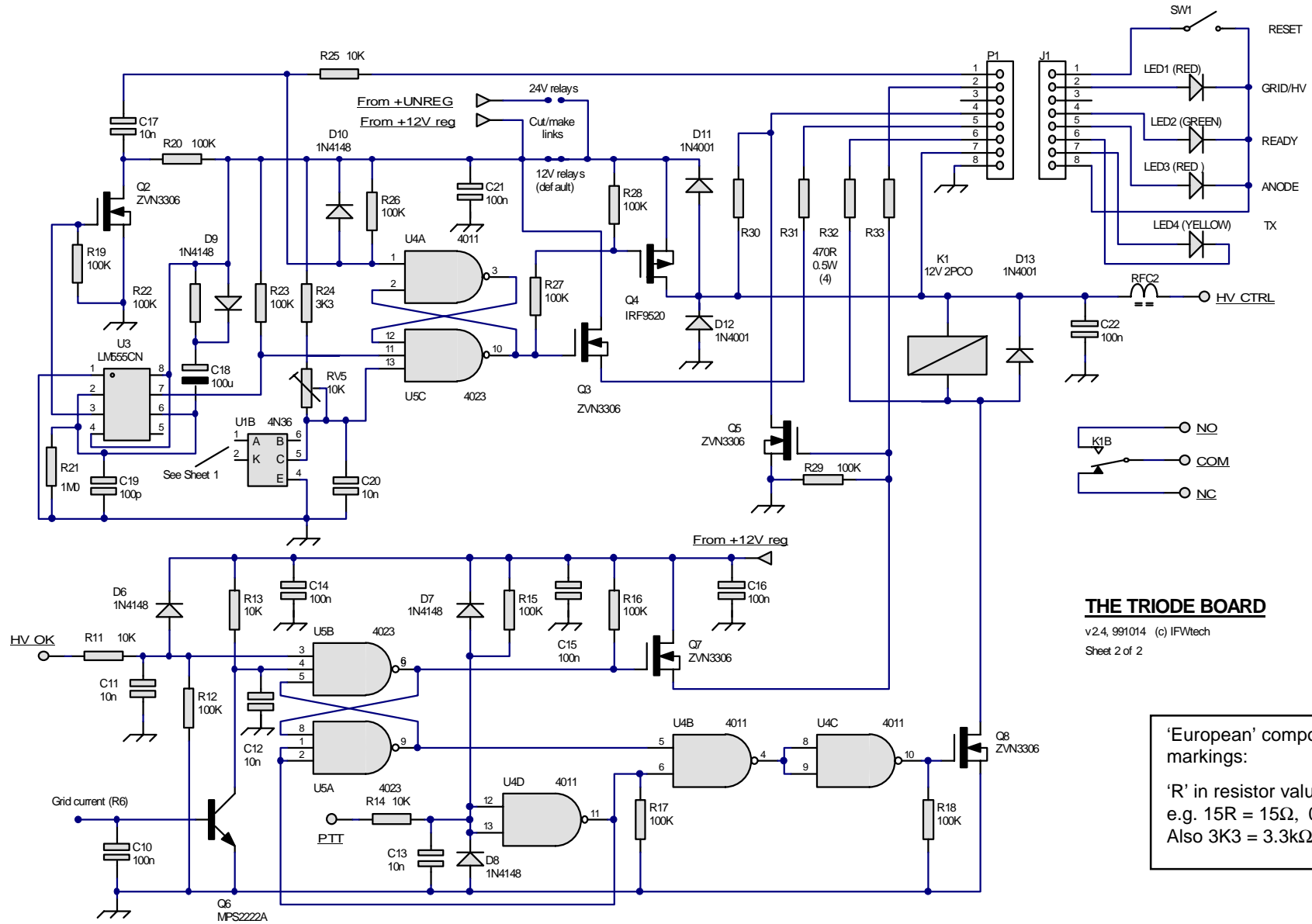

## THE TRIODE BOARD

v2.4, 991014 (c) IFWtech  
Sheet 2 of 2

'European' component markings:  
 'R' in resistor values means  $\Omega$ ,  
 e.g. 15R = 15 $\Omega$ , 0R33 = 0.33 $\Omega$ .  
 Also 3K3 = 3.3k $\Omega$  etc.

# Triode Board Layout

Actual size 5.7 x 3.3 in (145 x 84 mm)

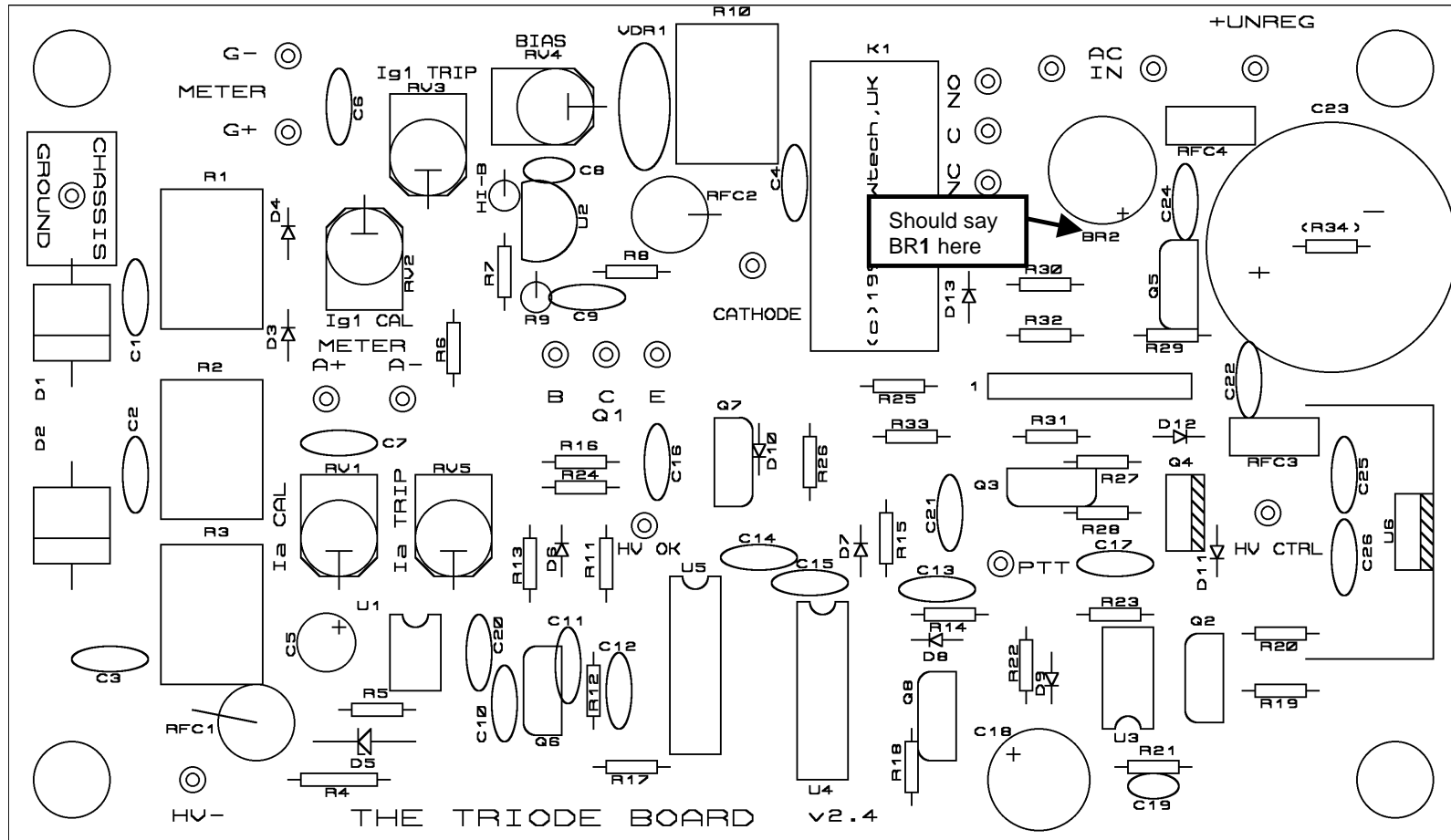



## Triode Board Parts List

There are many sources for most of these components. The **Stock Nos** columns show mostly Farnell order codes (F: ) and some from Digi-Key in the USA (DK: ).

Farnell (<http://www.farnell.com/uk>) have associate companies in many countries, including Farnell Chicago (1 800 718 1977 – note that US order codes may differ). Mouser Electronics and Digi-Key are also good sources in the USA

Resistors and capacitors may be subject to minimum order quantities. Small quantities can often be bought more cheaply from other dealers, e.g. Maplin in the UK.

### Capacitors

Total	C No.	Value	Volts (at least)	Comments	Stock Nos
1	C19	100pF	16	Ceramic, 0.1" radial leads	F:237-048
1	C8	470pF	16	Ceramic, 0.1" radial leads	F: 237-127
6	C9, C11, C12, C13, C17, C20	10n (0.01uF)	16	Multilayer ceramic, 0.2" radial leads	F: 750-840
2	C3, C4	10n (0.01uF)	200	Ceramic disk, 0.2" radial leads	F: 219-496
13	C1, C2, C6, C7, C10, C14, C15, C16, C21, C22, C24, C25, C26	100n (0.1uF)	63/50	Multilayer ceramic, 0.2" radial leads	F: 750-992
1	C5	1uF	50	Electrolytic, 0.1" radial	F: 920-691
1	C18	100uF	16	Electrolytic, 0.1" radial	F: 920-435
1	C23	4700uF	35	Electrolytic, Panasonic TSUP	F: 652-088 DK: P6905-ND

### Resistors

'R' in resistor values means  $\Omega$ , e.g. 15R = 15 $\Omega$ , 0R33 = 0.33 $\Omega$ , 3K3 = 3.3k $\Omega$ , 1M0 = 1.0M $\Omega$  etc.

Total	R No.	Value ("R"= $\Omega$ )	W	Comments	Stock Nos
1	R2	0R33, 0R47 or 1R0	5W	Vertical mounting, e.g. F: SQM5 series	See catalogs
1	R1	2R2, 3R3, 4R7, 6R8 or 15R	5W	(Mouser have similar) -or- 5W axial lead, mounted vertically, e.g.	See catalogs
1	R3	2R2 or 3R3	5W	DK: YAGEO series	See catalogs

The kit includes a total of 9 resistors for R1–R3. Select 3 using the table on page 12.

## Triode Board Parts List

1	R9	47R	0.25W		F: 543-068
1	R8	100R	0.25W		F: 543-147
4	R30, R31, R32, R33	470R	0.5W	24V relay option: R30, R32 = 1K 1-2W	F: 333-712
2	R5, R7	1K0	0.25W		F: 543-380
1	R4	1K0	1W	MF power, e.g. BC (formerly Philips) PR01	F: 337-857
1	R24	3K3	0.25W	Use 2K2 for alarm at higher current – see Section 6.3.3.	F: 543-500
6	R6, R11, R13, R14, R25, R34	10K	0.25W		F: 543-627
1	R10	10K	5/7W	As R1-R3	F: 987-750
13	R12, R15, R16, R17, R18, R19, R20, R22, R23, R26, R27, R28, R29	100K	0.25W	24V relay option:  R28 = 10K,  R27 = 15V 0.3-0.5W zener, e.g. BZX79C15 or 1N4109 etc. See Section 3.6.	F: 543-860
1	R21	1M0	0.25W		F: 544-103
<b>Total</b>	<b>RV No.</b>	<b>Value</b>	<b>Comments</b>		<b>Stock Nos</b>
1	RV1	5K, 2K, 500R, 200R, 50R or 20R (see text)	Bourns 3306P series or Bourns 3309 series (NB not available below 100R)		See catalogs
1	RV2	10K, 5K, 1K, 500R, 100R or 50R (see text)	Bourns 3306P series or Bourns 3309 series (NB not available below 100R)		See catalogs
1	RV3	500R	Bourns 3306P series or Bourns 3309 series		F: 108-235 F:452-580
2	RV4, RV5	10K	Bourns 3306P series or Bourns 3309 series		F: 108-239 F:452-622

## Triode Board Parts List

**Semiconductors etc**      \* = not supplied in kit.

Total	Part No.	Type	A / PIV / W	Comments	Stock Nos
1	BR1	AM152 (2W02)	1-2A 100-200V		F: 330-7918 DK:RB152DI-ND
2	D1, D2	GI750	6A, any PIV	400A surge rating	F: 364-940 DK: 6A05MSCT-ND
5	D3, D4, D11, D12, D13	1N4001	1A	Or any higher- numbered 1N400x	F: 251-677
5	D6, D7, D8, D9, D10	1N4148			F: 368-106
1	D5	1N5337B	4.7V 5W		F: 933-119
1	K1	8A 2PCO	12VDC	Schrack or Potter & Brumfield RTE24012	F:625-589 DK: PB296-ND
		24V relay option: use RTE24024 *		Schrack or Potter & Brumfield RTE24024	F: 625-590 DK: PB297-ND
2 *	LED1, LED3	Red	Normal 20mA	GRID/HV and ANODE indicator	
1 *	LED2	Green	Normal 20mA	READY indicator	
1 *	LED4	Blue / Yellow	Normal 20mA	TX indicator	
2 *	M1, M2	Meters (see text)			
1	Q1	TIP147	100V 10A	PNP Darlington, B-C-E pinout	F: 434-7894
5	Q2, Q3, Q5, Q7, Q8	ZVN3306A	60V 5A Rds(ON) 5Ω	N-MOSFET, S-G-D pinout	F: 352-901
1	Q4	IRF9530N	100V 13A, Rds(ON) 0.2Ω	P-MOSFET, G-D-S pinout	F: 934-616
1	Q6	MPS2222A	40V NPN, hFE 100 min	E-B-C pinout	F: 682-214
2	RFC1, 2	15μH 4A	Siemens B82111-B-C23 or equivalent ferrite-cored RF choke, end mounted		F: 505-870
2	RFC3, 4	30μH 500mA	Siemens miniature toroid RF choke or similar		F: 312-4873
1 *	SW1	Push switch	SPST		
1 *	T1	15V AC	1A	For 24V relays, use 20V AC.	
1	U1	4N36	Current transfer ratio 100% @ 10mA		F: 326-069
1	U2	TL431CZ (or CLP) or LM431ACZ	2.5-35V	"Adjustable zener"	F: 571-120 DK: LM431ACZ-ND

## Triode Board Parts List

1	U3	LM555CN		Must be CMOS	F: 409-340
1	U4	4011		CMOS 4 x 2-input NAND gate	F: 573-632
1	U5	4023		CMOS 3 x 3-input NAND gate	F: 384-835
1	U6	MC7812CT	12V 1A reg		F: 492-190
2	VDR1	V24ZA50	Harris-GE or Panasonic	For high bias option (>30V) use two VDRs in series – see page 10.	F: 318-346 DK: P7317-ND

**Hardware etc.**      \* = not supplied in kit.

Total	Part No.	Type	Comments	Stock Nos
1 *	(none)	TO218 heatsink (Q1) –	Transistor outline also known see text. User to provide.	
1	(none)	TO218 mounting kit (Q1)	User provides nut & bolt. No grease required.	F: 522-648
1	(none)	TO-220 heatsink (U6)	No insulating washer required. User provides nut & bolt.	F: 170-070 DK: HS222-ND
1	(none)	6 DIL socket (U1)		
1	(none)	8 DIL socket (U3)		
2	(none)	14 DIL socket (U4, U5)		
25	(none)	Connector blades, PCB	2.8mm (0.110in) x 0.8mm	F: 347-2528
25	(none)	Blade sockets	2.8mm (0.110in) x 0.8mm	F: 362-5394
1 *	P1/J1	8-way 0.1in header and connector	For LEDs and SW1 (optional)	
1 *	(none)	3-way 0.2-in header and connector	For Q1 (optional, or use blades)	

# **THE TRIODE BOARD** <sup>TM</sup>

*Control and Protection  
for your  
Triode RF Power Amplifier*

## **Application Note 5**

### **Higher Cathode Bias**

This Application Note explains how to modify the existing bias circuit for the higher voltages required by the Russian GS31 and GS35 triodes.

## Appendix 1

### 1. Original Bias Circuit

As you know, the Triode Board uses a **true constant-voltage bias regulator** which is **fully adjustable**, so you can set the idling current exactly as the manufacturer recommends. The circuit is taken from the data sheet for the industry-standard TL431 'adjustable zener' (U2). Voltage regulation is within a few millivolts, from idling currents of <50mA up to at least 2.5A.

An inexpensive Darlington power transistor Q1 handles the power dissipation, and is rated to survive major current surges. The Varistor VDR1 provides further circuit protection.

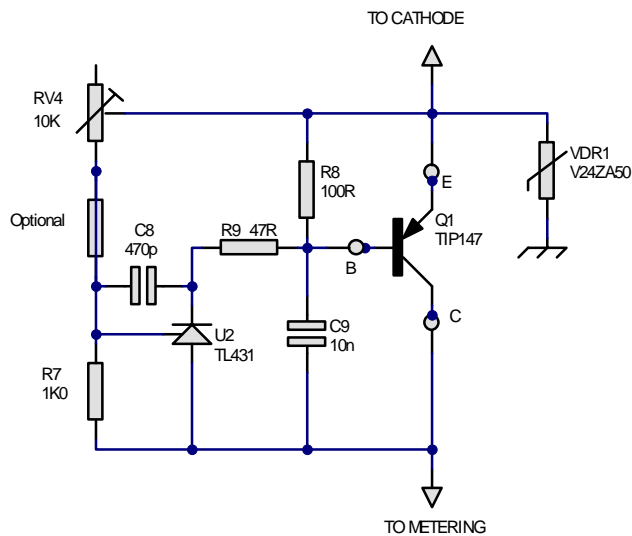

The cathode bias voltage is normally adjustable in the range from 3 to 27V, which suits most tubes including the 3-500Z, 3CX800 and 8877.

For tubes such as the GS35b and GS31b, which can require more than 30V bias at high anode voltages, you can insert an extra resistor as shown. However, experience shows that the voltage required is higher than anticipated, and can exceed the 36V breakdown voltage of the TL431.

### 2. Increasing the Bias Voltage

This note gives a simple modification to moves the range of bias adjustment up to 27–45V. This is plenty high enough for the Russian triodes, even at extreme anode voltages.

The modification is simply to insert a zener diode in series with U2. This reduces the voltage across U2, but it does not affect the voltage regulation because the zener is inside the DC feedback loop. The schematic is shown on the next page.

ZD is a BZX79C15 zener diode, and C is a 100nF bypass capacitor to remove any avalanche noise from the diode. The resistor R (inserted by cutting the track as shown in the manual) is increased to 10kΩ.

The optimum VDR combination for this bias voltage is two V24ZA50s in series. This combination will not start to conduct over the available voltage range (which could be a problem with some samples of the 33V VDR previously recommended).



# The Triode Board

