

# Network Management Card

User manual

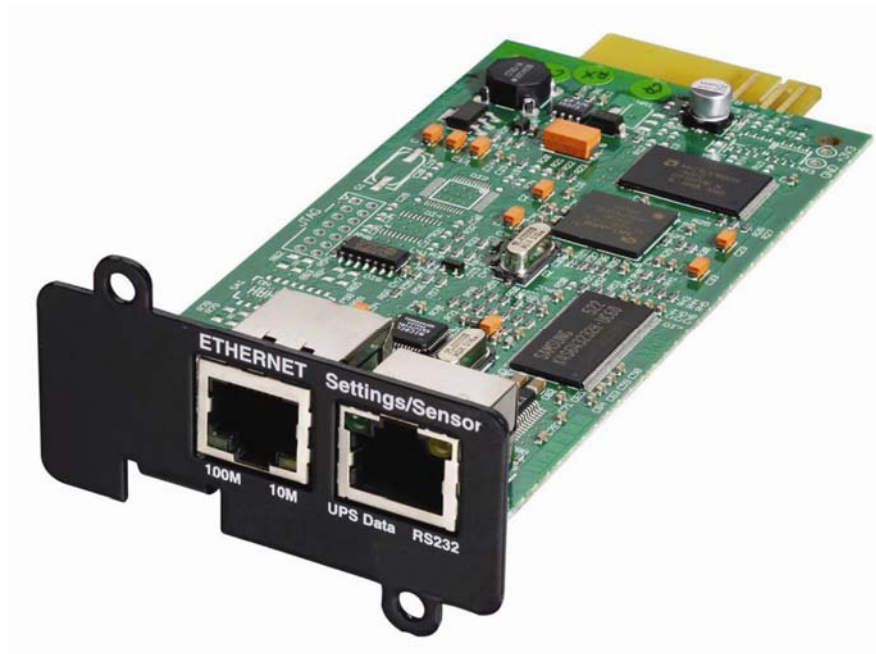

## Contents

<b>1</b>	<b>EATON NETWORK SOLUTION</b>	<b>5</b>
<b>1.1</b>	<b>GENERAL PRESENTATION</b>	<b>5</b>
1.1.1	Connecting the UPS to the Ethernet network	6
1.1.2	Protection of the computers/servers	6
1.1.3	Supervision of the UPSs over the network	7
1.1.4	Connection	7
<b>1.2</b>	<b>PRESENTATION OF THE NETWORK MANAGEMENT CARD (NMC)</b>	<b>8</b>
1.2.1	Compatibility with UPSs	8
1.2.2	Direct sending of E-mail	9
1.2.3	Sending text messages (SMS)	9
1.2.4	Compatibility with the Network Management Systems (NMS) – Trap sending	9
1.2.5	Environment Sensor (option)	9
<b>1.3</b>	<b>TECHNICAL DATA</b>	<b>10</b>
1.3.1	Hardware characteristics	10
1.3.2	EMC Compatibility	10
1.3.3	Configuration	10
1.3.4	Administration	11
1.3.5	Network	11
1.3.6	Environment sensor	11
1.3.7	MIB (Management Information Base)	12
1.3.8	Default parameters	13
<b>2</b>	<b>INSTALLATION</b>	<b>14</b>
<b>2.1</b>	<b>UNPACKING AND CHECK ON CONTENTS</b>	<b>14</b>
<b>2.2</b>	<b>INDICATIONS</b>	<b>14</b>
<b>2.3</b>	<b>INSTALLATION IN THE UPS</b>	<b>15</b>
<b>2.4</b>	<b>SENSOR INSTALLATION (OPTION)</b>	<b>16</b>
<b>3</b>	<b>CONFIGURATION</b>	<b>17</b>
<b>3.1</b>	<b>CONFIGURE IP PARAMETERS</b>	<b>17</b>
3.1.1	Your network is equipped with a DHCP server	18
3.1.2	Your network is not equipped with a DHCP server	19
<b>3.2</b>	<b>TEST AFTER CONFIGURATION</b>	<b>19</b>
<b>4</b>	<b>SUPERVISION AND ADMINISTRATION BY BROWSER</b>	<b>20</b>
<b>4.1</b>	<b>OPTIMISING THE PERFORMANCE OF YOUR BROWSER</b>	<b>20</b>
<b>4.2</b>	<b>UPS</b>	<b>21</b>
4.2.1	UPS properties page	21
4.2.2	On-line help	33

4.2.3	UPS control	34
4.2.4	UPS weekly schedule programming	37
4.2.5	Shutdown parameters	38
4.2.6	Measurements	40
4.2.7	Event log	41
4.2.8	System log	42
<b>4.3</b>	<b>NOTIFICATION</b>	<b>43</b>
4.3.1	Email Notification	43
4.3.2	E-mail Message Settings	45
<b>4.4</b>	<b>CONFIGURATION</b>	<b>47</b>
4.4.1	Network settings	48
4.4.2	System	50
4.4.3	Notified Applications	51
4.4.4	Central shutdown configuration	53
4.4.5	Access control	55
4.4.6	Date and time	57
4.4.7	Firmware upload	59
<b>4.5</b>	<b>ENVIRONMENT SENSOR (OPTION)</b>	<b>60</b>
4.5.1	Characteristics	60
4.5.2	Environment Status	61
4.5.3	Environment Settings	62
4.5.4	Log	64
<b>5</b>	<b>SERVER PROTECTION</b>	<b>65</b>
<b>5.1</b>	<b>SET-UP OF THE SHUTDOWN PARAMETERS</b>	<b>65</b>
5.1.1	Shutdown criteria managed by the Network Management Card	65
5.1.2	Controlled outlets	68
5.1.3	Protection of a server connected to a controlled outlet	68
<b>5.2</b>	<b>THE DIFFERENT SERVER AND UPS SHUTDOWN SEQUENCES</b>	<b>69</b>
5.2.1	Extended power outage, shutdown initiated by the Shutdown Timer (Shutdown after)	69
5.2.2	Extended power outage, shutdown initiated by the "Low battery power" message	69
5.2.3	Case of power restoration before the end of the "shutdown duration" counter	70
<b>5.3</b>	<b>SHUTDOWN MANAGEMENT WITH 2 NMC BOARDS</b>	<b>71</b>
5.3.1	Shutdown Duration	71
5.3.2	Settings	71
<b>6</b>	<b>CONFIGURATION VIA RS232</b>	<b>72</b>
<b>6.1</b>	<b>CHOICE 1: RESTART / RESET</b>	<b>73</b>
<b>6.2</b>	<b>CHOICE 2: NETWORK CONFIGURATION</b>	<b>73</b>
6.2.1	Choice 1: Read Network settings	73
6.2.2	Choice 2: Modify Network settings	74
6.2.3	Choice 3: Set Ethernet speed	74

<b>6.3</b>	<b>CHOICE 3: LOST PASSWORD / SET LOGIN PASSWORD TO DEFAULT</b>	<b>75</b>
<b>6.4</b>	<b>CHOICE 4: RETURN TO DEFAULT CONFIGURATION</b>	<b>76</b>
<b>7</b>	<b>APPENDIX</b>	<b>77</b>
<b>7.1</b>	<b>TABLES OF ALARMS AND EVENTS</b>	<b>77</b>
7.1.1	Table of alarms	77
7.1.2	Table of UPS events	80
7.1.3	Table of system alarms	83
<b>7.2</b>	<b>SNMP OBJECTS</b>	<b>84</b>
7.2.1	IETF Mib	84
7.2.2	EATON Pulsar MIB (ex MGE)	84
7.2.3	TRAPS table: (1.3.6.1.4.1.705.1.11)	87
7.2.4	EATON Powerware MIB	88
<b>8</b>	<b>GLOSSARY</b>	<b>92</b>

# 1 EATON Network Solution

## 1.1 General Presentation

EATON Network Solution:

- Provides information on events concerning the supply of power to the computers connected to your computer network,
- Carries out automatic shutdown of computer systems,
- Monitors and controls all the UPSs connected to the network.

EATON Network Solution provides 3 main functions:

- Supervision of the UPSs over the Network : Web browser, Intelligent Power Manager, or SNMP NMS.
- Protection of the computers (multi-platform) with:
  - Network Shutdown Module for EATON.
  - Netwatch for Powerware UPS.
- Connexion of the UPS to the Network.

### **1.1.1 Connecting the UPS to the Ethernet network**

This function can be performed through network Cards inserted in the UPS (Network Management Card). Also a software "agent" running on a nearby PC that is called the Network Management Proxy can be used.

The Network Management Card or Proxy:

- manages communication with the UPS (as well as local protection of the machine on which Proxy is installed)
- periodically accesses the information concerning the UPS
- makes this information available to the connected applications (Network Shutdown Modules, Netwatch, Web Browser, Network Management Systems, Intelligent Power Manager)
- sends notifications on certain events.

Operation may be in standard secure mode (the default mode) or in SSL secure mode (Secure Socket Layer SSL).

### **1.1.2 Protection of the computers/servers**

This function is performed by:

- Network Shutdown Module for EATON
- Netwatch for Powerware UPS

installed on each of the servers to be protected.

Note that Network Shutdown Module and Netwatch are available on several Operating Systems.

Both protection applications:

Continuously waits for information from the Network Management Card/Proxy connected to the UPS.

Warns administrators and users if AC power fails and proceeds with graceful system shutdown before the end of battery backup power is reached.

### 1.1.3 Supervision of the UPSs over the network

Depending on your needs, you can either use:

- Your Internet browser to monitor each UPS, as Management Proxy and Management Card includes a Web server
- Your company's standard Network Management System (HP-Openview, CA Unicenter, HP Insight Manager, IBM Tivoli Netview)  
To simplify integration of EATON UPSs, you can use one of the Network Management System Kits for EATON devices. These kits are available on the Management Pac 2 CD-ROM. (ref 66923)
- The supervisor "Intelligent Power Manager".

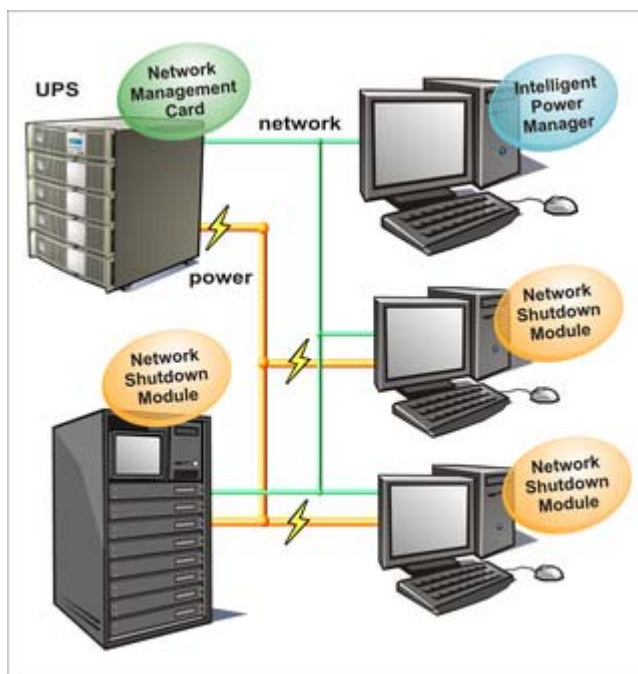

### 1.1.4 Connection

Before installing the Network Solution, the UPS must be set up as indicated in the steps below.

Shut down the computers to be protected by the UPS.

Connect the UPS to a wall outlet. (For UPSs above 3kVA, please refer to the UPS installation manual).

Connect the power cord of each computer to an outlet on the UPS. (For UPSs above 3kVA, please refer to the UPS installation manual)

#### 1.1.4.1 How to connect UPS / agent / network:

Insert the optional card in the UPS and connect the UPS to the computer network.  
Start the UPS, then the computers.

#### 1.1.4.2 Setting up the protection:

Set up the Network Management Card (see user manual).

Install and configure the protection application on all machines that are to be protected by the UPS:

- Network Shutdown Module for EATON Pulsar UPS : The software components for each platform and the user manuals are on the Solution-Pac-2 CD or available at <http://download.mgeops.com>
- Netwatch for Powerware UPSs : The software components for each platform and the user manuals are available at <http://powerquality.eaton.com>

## 1.2 Presentation of the Network Management Card (NMC)

### 1.2.1 Compatibility with UPSs

The Minislot Network Management Card is compatible with the UPS listed into the compatibility list:

- available at <http://download.mgeops.com/> for the EATON Pulsar UPSs.
- available at <http://powerquality.eaton.com> for the Powerware UPSs.

Network Management Cards acquire information on the operation status of the UPS systems and provide remote control of these systems by means of an ETHERNET network from any SNMP administration station or Web browser.

They also supply alarms to the Network Shutdown Modules to trigger shutdown or other automatic actions for protected servers.



Network Management Cards are compatible with the "Intelligent Power Management" supervision system, with the EATON network protection system and with Powerware Networkwatch.

[Network Shutdown Module](#)

[Intelligent Power Manager](#)

[Management-Pac 2](#)

## 1.2.2 Direct sending of E-mail

When a UPS event occurs, the Network Management Card can directly notify up to 4 intranet or extranet addresses by e-mail. (see E-mail Notification and [E-mail message settings](#))

## 1.2.3 Sending text messages (SMS)

SMS notification requires the use of a third-party application that converts emails to SMS. The card offers the possibility of redirecting UPS alarms to an e-mail server. The format of these e-mails is compatible with mobile telephone e-mail/SMS transfer systems proposed by ISPs. The format to be used depends on the service provider.

For example, [sms.0660256585@your-login.activmail.net](mailto:sms.0660256585@your-login.activmail.net) (text messages).

## 1.2.4 Compatibility with the Network Management Systems (NMS) – Trap sending

The Network Management Cards are compatible with the major Network Management Systems (IBM Tivoli, CA Unicenter, HP Insight Manager). The Management-Pac 2 offering includes the necessary SNMP plug-ins to allow an easy integration in the NMS. Events are notified by SNMP trap.

NMS can subscribe on page "[Notified Applications](#)"

The trap list is given in the [appendix](#).

## 1.2.5 Environment Sensor (option)

The [Environment Sensor](#) (66846) solution comprises a box to be connected to the Card Settings port of the Network Management Cards.

Environment Sensor enables measurement of temperature and humidity around the UPS, consideration of external alarms via 2 dry contacts and notification of alarms according to pre-programmed thresholds. (see [Environmen Status](#) and [Environment Configuration](#))

## 1.3 Technical data

### 1.3.1 Hardware characteristics

#### Dimensions

Dimensions (L x l x H) 132 x 66 x 42 mm

Weight (gr) 70 g

#### Storage

Storage temperature -10 °C to 70 °C

#### Ambient conditions

Operating temperature 0 °C to 40 °C

Ambient humidity 90 % RH max without condensation

ROHS 100 % compatible

### 1.3.2 EMC Compatibility

When correctly installed and used in accordance with the manufacturer's instructions, the Network Management Card complies with the following standards:

Safety for ATI: IEC/EN 60950-1 2002

EMC: EN 61000-6-2 (2002), EN 61000-6-3 (2002). IEC/EN 62040-2 (2002).

As per European directives:

Low voltage: 73/23/EEC and 93/68/EEC

EMC: 89/336/EEC and 93/68/EEC.

### 1.3.3 Configuration

Easy installation—the NMC Card can be installed while the UPS is online, maintaining the highest system availability

The user can configure the card with one of the following means:

- Web browser
- Local serial link (network parameters)
- BOOTP/DHCP (network parameters).

### 1.3.4 Administration

- Up to 35 workstations (in TCP connected mode) or up to 100(in UDP broadcasted mode) protected by Network Shutdown Modules - Central or local configuration.
- Up to 5 browsers connected at the same time (3 in SSL).
- Minimum recommended browser versions: Internet Explorer 6.x / 7 / 8, Mozilla Firefox 2.0 / 3.0 / 3.5
- E-mail sending configurable according to UPS alarms and transmission of a periodical report.
- Control of UPS on/off switching via the HTML interface.
- Adjustment and control of PowerShare outlets via the HTML interface, sequential starting of the installation and optimisation of backup time by shutting down non-priority systems.
- Automatic data and time adjustment via NTP server.
- Protection by encrypted password.
- Protection by secure SSL connection.
- Saving of logs in the non-volatile memory.
- Languages available: English / French/ Spanish / German / Italian / Chinese Traditional / Chinese Simplified / Japanese / Russian / Korean.
- On-line help in English available for each page.
- Card firmware update via the network.
- Card Mass settings via the network with Intelligent Power Manager.
- Firmware Mass Upgrade via the network with Intelligent Power Manager.

### 1.3.5 Network

Fast ETHERNET 10/100 Mbits compatibility with auto-negotiation on the RJ45 outlet.

#### 1.3.5.1 List of ports used

- |                             |               |
|-----------------------------|---------------|
| • BootP, DHCP               | UDP 68, 67    |
| • HTML                      | TCP 80        |
| • SSL                       | TCP 443       |
| • NSM in connected mode     | TCP 5000      |
| • NSM in UDP broadcast mode | 4679 and 4680 |
| • SMTP                      | 25            |
| • NTP                       | 123           |
| • SNMP V1                   | 161           |
| • TRAP SNMP                 | 162           |

### 1.3.6 Environment sensor

- Temperature measurement from 0 to 70 °C with +/- 1 °C accuracy.
- Measurement of humidity from 0 to 100 % with +/- 6 % accuracy.

- Min / max time-stamped function for temperature and humidity.
- Choice of temperature readings in Celsius or Fahrenheit.
- High and low thresholds, hysteresis and offset adjustable via Web interface.
- Possibility of notification of status changes by e-mail, SMS or SNMP trap.  
SMS notification requires the use of a third-party application that converts emails to SMS.
- Position detection of 2 dry contacts (maximum sensor/contact distance: 20 m).
- Name and status of each configurable contact.
- Recording of events and measurements in the card log
- Possibility of shutting down the installation in the event of a threshold being exceeded or on opening / closure of a dry contact
- Connection to the card with straight CAT5 RJ45 network cables (maximum card/sensor distance: 20 m)

### 1.3.7 MIB (Management Information Base)

The card is Compatible with following MIBs:

- MIB II (RFC 1213)
- Internet Engineering Task Force (IETF) Standard UPS MIB (RFC 1628)
- EATON Pulsar MIB (ex MGE) V1.7
- EATON Powerware MIB (PowerMib)

See the [appendix](#) Chapter

### 1.3.8 Default parameters

Function	Parameter	Default value	Possible value
<a href="#">Network</a>	IP address	192.168.1.2	Network IP address
	Subnet mask	255.255.0.0	Network IP address
	Gateway Address	0.0.0.0	Network IP address
	BOOTP/DHCP	Enabled	Active / Deactivated
	Firmware Upload	Enabled	Active / Deactivated
	SMTP server	smtpserver	49 characters maximum
<a href="#">System</a>	UPS Contact	Computer Room Manager	49 characters maximum
	UPS Location	Computer Room	31 characters maximum
	History log interval (sec.)	60	10 to 99999 sec.
	Environment log interval (sec.)	300	10 to 99999 sec.
	Default Language	English	English / French / Spanish / German / Italian / Chinese Traditional / Chinese Simplified / Japanese / Russian / Korean
<a href="#">Notified Application table</a>		empty	NA
<a href="#">Access control</a>	User name	admin	10 characters maximum
	Password	admin	10 characters maximum
	Community name read	public	49 characters maximum
	Trap port	162	Not configurable
<a href="#">Date and time</a>	Date and time adjustment	Accept automatic update from NSM or EPM	Synchronise with an NTP server Accept automatic update from NSM or EPM Synchronise manually
	NTP server	ntpserver	49 characters maximum
Serial link	Speed	9600 baud	Not configurable
	Data bits	8	Not configurable
	Stop bits	1	Not configurable
	Parity	without	Not configurable
	Flow control	without	Not configurable

## 2 Installation

### 2.1 Unpacking and check on contents

The installation kit contents:

A Network Management Card (66102)

A serial communication cable for configuration (**34003918**)

Installation manual (**34003905**)

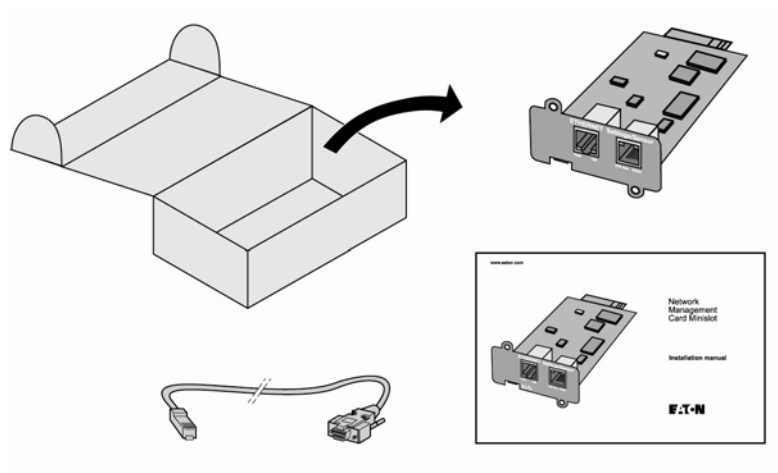

### 2.2 Indications

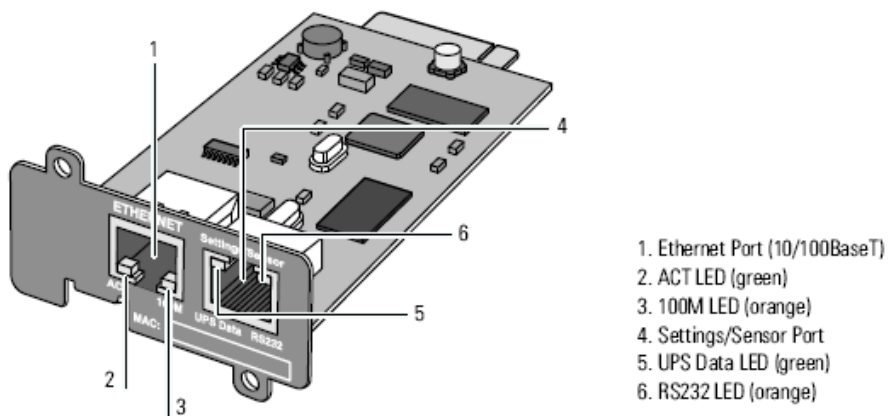

## Ethernet Port

LED	Colour	Activity	Description
ACT	Green	Off	Card not connected to the network.
		On	Card connected to the network but without activity
		Flashing	Port is active in receiving / transmission
100M	Orange	Off	Port operating at 10Mbits/s.
		On	Port operating at 100Mbits/s.

## Settings/Sensor Port

LED	Colour	Activity	Description
UPS Data	Green	Off	Card startup in progress.
		On	Communication with UPS in progress
		Flashing	Normal operation. Communication with the UPS is operational
RS232	Orange	Off	Configuration menu is active
		On	Normal operation. Configuration menu is deactivated
		Flashing	Communication with the Environment Sensor (option).

## 2.3 Installation in the UPS

The Network Management Card (66102) is "hot-swappable". It can be installed in all UPSs of the EATON Pulsar or Powerware range equipped with a Minislot without having to shut it down.

- Remove the protective plastic cover from the Minislot
- Note the card's MAC address

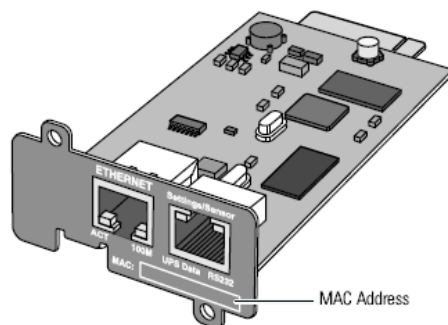

- Insert and tighten the card's retaining screws
- Connect the ETHERNET cable
- Wait 2 min. the card is completely operational when the green UPS Data LED flashes continuously

## 2.4 Sensor installation (option)

The Environment sensor is available as an option on the Network Management Card and is available from EATON (reference 66846).

The sensor allows remote monitoring of the UPS's environment through regular measurements: temperature, humidity, status of two external contacts. It also enables notification of alarms (e-mail, trap SNMP) according to pre-programmed thresholds.

It is connected to the Service port (Settings/Sensor) directly on the Network Management Card with a standard Ethernet cable (20 meters maximum).

Recognition is automatic. Supervision and configuration are performed via a menu that can be accessed directly from the home page.

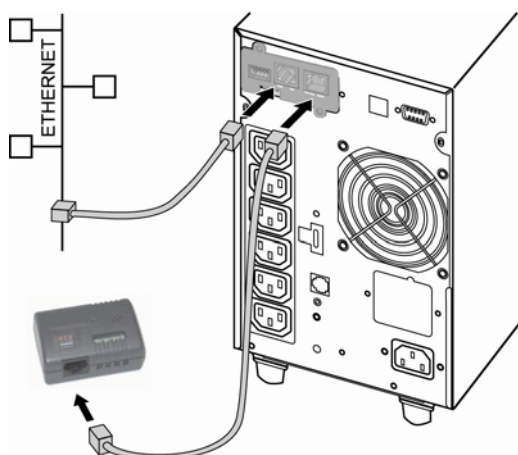



## 3 Configuration

### 3.1 Configure IP parameters

Once the card has started:

Connect one end of the cable (34003918) to the Service port.

Connect the other end of the cable to the COM port (IOIOI) of a PC.

Launch a HyperTerminal™ type emulator with the following configuration:

- Speed: 9600
- Data bits: 8
- Parity: none
- Stop bits: 1
- Flow control: none
- "Locally reproduce the characters entered" option: deactivated.

Enter admin. The main menu is displayed:

```
-----  
EATON  
NETWORK MANAGEMENT CARD  
-----  
1 : Reset  
2 : Network configuration  
3 : Set Login Password to Default  
4 : Return to Default Configuration  
0 : Exit  
-----
```

### 3.1.1 Your network is equipped with a DHCP server

The card is configured by default with this service activated.

The card automatically collects IP parameters.

To know the IP parameters, type 2, the next menu is displayed:

```
-----  
Network settings  
-----  
 1 : Read Network settings  
 2 : Modify Network settings  
 3 : Set Ethernet speed  
 0 : Exit  
-----
```

Then type 1. The menu is displayed:

```
Network configuration :  
  MAC address : 00:20:85:FD:1C:07  
  Mode : Static IP  
  IP address : 166.99.21.94  
  Subnet mask : 255.255.248.0  
  Gateway 166.99.17.1
```

Note the IP address.

To exit, enter 0 then 0. The card is operational.

Note: As long as the card is not connected to the network, it continuously attempts to make connection. Once the connection has been established, the operational mode presented in the table above becomes effective.

### 3.1.2 Your network is not equipped with a DHCP server

In the main menu enter 2, then 2 again. The menu is displayed:

Follow the instructions and enter the static IP parameters.

At the end of the menu, wait for the "Done" message to be displayed indicating that the IP parameters have been saved.

```
-----  
Network settings  
-----  
 1 : Read Network settings  
 2 : Modify Network settings  
 3 : Set Ethernet speed  
 0 : Exit  
-----  
For each of the following questions, you can press <Return> to select the  
value  
shown in braces, or you can enter a new value.  
Should this target obtain IP settings from the network?[N] N  
Static IP address [166.99.21.94]? 166.99.21.21  
Static IP address is 166.99.21.21  
Subnet Mask IP address [255.255.248.0]? 255.255.255.0  
Subnet Mask IP address is 255.255.255.0  
Gateway address IP address [166.99.17.1]? 166.99.17.1  
Gateway address IP address is 166.99.17.1  
Wait during your new configuration is saved ...  
Reset the card to take into account the new configuration.
```

Return to the main menu and enter 1 then 2.

The card restarts with the new IP parameters.

## 3.2 Test after configuration

To check that the Network Management Card is operational after installation and configuration:

From a station connected to the same subnet as the card, open a web browser and enter the IP address of the card in the address field

Check the display of the [home page](#).

## 4 Supervision and administration by browser

On a computer equipped with a Web browser (Internet Explorer, FireFox, ... ), enter the address initialised previously in the Installation chapter (e.g. <http://166.99.21.21>.)

The "UPS properties" home page is displayed.

### 4.1 Optimising the performance of your browser

To view status changes on the UPS in real time, the browser must be configured so that it automatically refreshes all the objects on the current page.

Example on IE 6: Tools / Internet Options / General / Parameters menu, tick Every time this page is visited and validate.

## 4.2 UPS

### 4.2.1 UPS properties page

This page is automatically refreshed every 10 seconds.

From this page, access to the main UPS information is available thanks to the combo box (see screen copy below).

The different choices are the following ones:

- **UPS Status:** (chosen by default) this page gives instant access to the essential information about your UPS.
- **UPS Alarms:** to view the list of current alarms.
- **UPS Modules:** (available on modular UPS) to view general information on each module.
- **About your UPS:** provides information on the UPS and the card, in particular, the model range and software version.

These different pages are detailed in the following chapters.

#### Network Management Card

The screenshot displays the 'UPS Properties' page for a 'Pulsar M 2200 Computer Room' UPS. The interface includes a sidebar with navigation options and a main content area with a diagram and a status table.

**UPS Properties** Help

**UPS**

- UPS Properties
- UPS Control
- Weekly Schedule
- Shutdown Parameters

**Logs and Notification**

- Measurements
- Event Log
- System Log
- Email Notification

**Settings**

- Network
- System
- Notified Applications
- Access Control
- Time
- Firmware Upload

**UPS Status** (dropdown menu)

**Diagram:** A schematic diagram of the UPS system showing AC Power input, a battery, and output to a computer room.

Power source :	AC Power
Output load level :	 3%
Output :	Master : <b>On</b> Group1 : <b>On</b> Group2 : <b>On</b>

**Battery**

Battery load level :	 100% <b>Charging</b>
Remaining backup time :	1 h 37 mn 43 s
Battery status :	OK

Last update : 2008/06/12 17:24:21

#### 4.2.1.1 "UPS" zone: general information on the UPS.



Indication of the picture and generic name of the UPS range

Computer room: Customised name of your system.

You can change this name on the ["System"](#) page.

UPS status icon:

The various icons showing the status of the UPS are:

	Normal operation
	Alarm present. This icon links directly to the alarm page.
	Loss of communication with the UPS

**Animated synoptic:** An animated synoptic gives a global overview of the UPS current operating mode.

This synoptic is available on all On-Line UPS.

The synoptic drawing depends on the UPS topology. The different drawings are described in the table below.

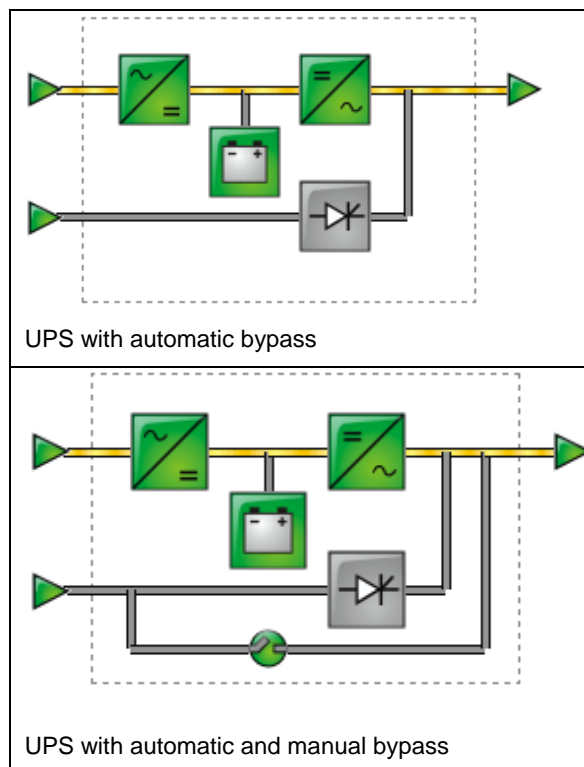

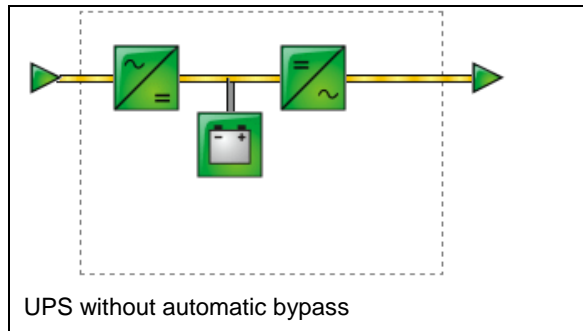

**Note:** In case of loss of communication with the UPS, all the elements of the synoptic are grey.

The various elements of the synoptic are the following ones:

AC Normal Input:

	Green	In tolerances
	Gray	Out of tolerances

AC Normal Flow:

	Yellow	AC to DC converter powered by AC Normal
	Gray	AC to DC converter not powered by AC Normal

AC to DC Converter:

	Green	Powered
	Gray	Not powered
	Red	Internal failure

Battery:



	Green	Remaining capacity > 50%
	Orange	Remaining capacity < 50%
	Red	Battery to be checked (battery test result)

Battery Output Flow:



	Yellow	DC to AC converter powered by battery
--	--------	---------------------------------------

	Gray	DC to AC converter not powered by battery
---	------	---



DC to AC Converter Input flow:

	Yellow	Energy flow present
	Gray	No energy flow



DC to AC Converter :

	Green	Powered
	Gray	Not powered
	Red	Internal failure



DC to AC Converter Output:

	Yellow	Energy flow present
	Gray	No energy flow



AC Bypass Input:

	Green	In tolerances
	Red	Out of tolerances



AC Automatic Bypass Flow :

	Yellow	Energy flow present
	Gray	No energy flow

AC Automatic Bypass Status:



	Green	Powered
	Gray	Not powered
	Red	Internal failure

AC Manual Bypass Flow:



	Yellow	Energy flow present
	Gray	No energy flow





AC Manual Bypass Status:

	Green / Gray	Open
	Red / Yellow	Closed

AC Output Flow:

	Yellow	Energy flow present
	Gray	No energy flow

AC Output:

	Green	Load protected
	Red	Load not protected

## UPS measurements :

A box displaying measurements appears when the mouse cursor is over one of the synoptic element. See example below.

**Network Management Card**

**UPS**

- [UPS Properties](#)
- [UPS Control](#)
- [Weekly Schedule](#)
- [Shutdown Parameters](#)

**Logs and Notification**

- [Measurements](#)
- [Event Log](#)
- [System Log](#)
- [Email Notification](#)

**Settings**

- [Network](#)
- [System](#)
- [Notified Applications](#)
- [Access Control](#)
- [Time](#)
- [Firmware Upload](#)

**UPS Properties** Help



**Pulsar M 2200**  
Computer Room



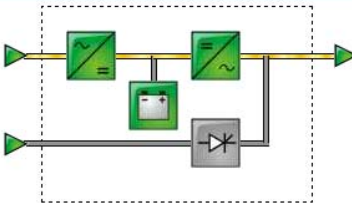



**AC Output**

Voltage	231 V
Current	0.4 A
Frequency	50.0 Hz
<hr/>	
Load level	4 %
Apparent Power	0.0 kVA
Active Power	0.0 kW

UPS Status: ▼

Power source :	AC Power
Output load level :	 4%
Output :	Master : <b>On</b> Group1 : <b>On</b> Group2 : <b>On</b>
<b>Battery</b>	
Battery load level :	 100% <b>Charging</b>
Remaining backup time :	1 h 37 mn 43 s
Battery status :	OK

Last update : 2008/06/12 17:25:35



These measurements are available for AC to DC converter, Battery, DC to AC converter and automatic bypass.

The measurements available in these boxes depend on the UPS range.

#### 4.2.1.2 "UPS status" zone: Essential information

- **Active sources:** (available on parallel or modular UPS)  
x UPS + y UPS redundant : x indicates the minimal number of UPS necessary to power the load, y indicates the number of UPS in redundancy.
- An alarm can be generated if the number of UPS in redundancy is less than a configurable threshold. See UPS modules section.
- **Power source:** indicates whether the power comes from the utility or from the UPS battery
- **Output load level:** indicates the power percentage used at UPS output
- **Output:** indicates if the different UPS outputs are protected.
- **Master:** indicates if the UPS main output is protected
- **Group1** and **Group2:** indicates if the controlled outlets (if available) are powered.

The various icons showing the status of the UPS outputs are:

 (green outlet)	Outlet powered
 (red outlet)	Outlet not powered or not protected

#### Battery Information:

- **Battery load level:** remaining battery charge (in percent).  
The information is completed with the two following labels:
- **Charging:** if the utility power is present and the battery charge is in progress
- **Discharging:** if the UPS operates on battery.
- **Fault:** if the battery is faulty.
- **Remaining backup time:** Estimation of the battery's maximum backup time remaining before UPS shutdown
- **Battery status:** Result of the last automatic battery test carried out by the UPS  
Possible values are:
  - **OK:** the test was completed correctly
  - **NOK:** the battery needs to be checked
  - **Deactivated:** the automatic battery test is not validated on the UPS

### 4.2.1.3 Viewing the modules

Click on **UPS Modules** scroll list to view the information about the UPS modules.

*Network Management Card*

**UPS**

- UPS Properties
- UPS Control
- Weekly Schedule
- Shutdown Parameters

**Logs and Notification**

- Measurements
- Event Log
- System Log
- Email Notification

**Settings**

- Network
- System
- Notified Applications
- Access Control
- Time
- Firmware Upload

**UPS Properties** Help



Pulsar MX Frame 16U  
Computer Room

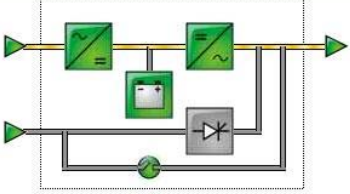

**UPS Modules** ▼

Active sources : 1 UPS + 3 UPS redundant

Minimum redundant UPS modules to trigger alarm : 1 Save

Module Nr	Status	Technical Level / Firmware Revision	Serial Nr	Output load level	Battery load level
1	✔	209	1V7G47011	██████████ 0%	██████████ 100%
2	✔	209	1V7G15032	██████████ 0%	██████████ 100%
3	✔	209	1V7G43020	██████████ 0%	██████████ 100%
4	✔	209	1V7G47017	██████████ 0%	██████████ 100%

**Active sources:**

x UPS + y UPS redundant : x indicates the minimal number of UPS necessary to power the load, y indicates the number of UPS in redundancy.

The addition of these 2 values is the total number of available UPS.

The **Minimum redundant UPS modules to trigger alarm** can be configured from this page. The button **Save** makes the card setting the parameter into the UPS. A warning message informs the user about the consequences of this parameters modification.

The redundancy lost can generate Email notification (if set in the email notification page) and SNMP trap. It can also be used by NSM for server protection criteria.



The **Module Nr** gives the location of the module in the UPS.

Network Management Card – User Manual

34003991EN/ED

Page 28/93

The **Status** can take the next forms:

 or  when the module is working properly with no alarm.

 when the module has at least one alarm (level Warning) active.

 when the module has at least one alarm (level Critical) active.

 when the module has a communication fault.

When the module is working properly with no alarms, the icon is not reactive, otherwise it is reactive and clicking on it makes the page Alarm Table appear.

**Output load level:** Value of the percentage of load at module output

**Battery load level:** Percentage of charge available in the battery module

#### 4.2.1.4 Viewing the alarms

Click on "Alarm Table" scroll list to view the list of current alarms. The table of managed alarms is included in the [appendix](#).

The level of the alarms appears like below:

-  Critical
-  Warning
-  Unknown

Alarm table for standard UPS:

**Network Management Card**

**UPS**

- UPS Properties
- UPS Control
- Weekly Schedule
- Shutdown Parameters

**Logs and Notification**

- Measurements
- Event Log
- System Log
- Email Notification

**Settings**

- Network
- System
- Notified Applications
- Access Control
- Time
- Firmware Upload





**UPS Properties** Help

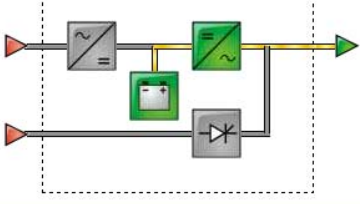

**Pulsar M 2200**  
Computer Room



UPS Alarms

	Alarm Time	Alarm Description	Severity
UPS	2008/06/12 17:28:46	Normal AC voltage out of tolerance	
	2008/06/12 17:28:49	Normal AC NOK	
	2008/06/12 17:28:49	UPS on battery	
	2008/06/12 17:28:51	Bypass AC voltage out of tolerance	

Alarm table for modular UPS:

*Network Management Card*

**UPS**

- UPS Properties
- UPS Control
- Weekly Schedule
- Shutdown Parameters

**Logs and Notification**

- Measurements
- Event Log
- System Log
- Email Notification

**Settings**

- Network
- System
- Notified Applications
- Access Control
- Time
- Firmware Upload

**UPS Properties** Help



**Pulsar MX Frame 16U**  
Computer Room



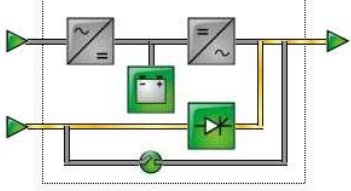

**UPS Alarms** ▼

	Alarm Time	Alarm Description	Severity
UPS	2008/06/18 10:11:55	Load not protected - On Automatic Bypass	⚠

#### 4.2.1.5 Viewing the “About your UPS” page

Click on **About your UPS** scroll list to view the information about the UPS and the card.

**Network Management Card**

**UPS**

- UPS Properties
- UPS Control
- Weekly Schedule
- Shutdown Parameters

**Logs and Notification**

- Measurements
- Event Log
- System Log
- Email Notification

**Settings**

- Network
- System
- Notified Applications
- Access Control
- Time
- Firmware Upload

**UPS Properties** Help

 **Pulsar M 2200**  
Computer Room



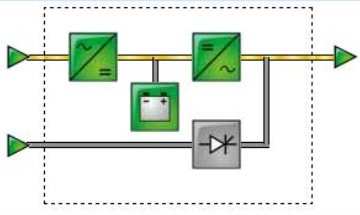

**About your UPS**

UPS Name :	Pulsar M 2200
UPS Serial Number :	012345678
UPS Technical Level :	unknown
System Technical Level / Firmware Revision :	SW: AH

**Network Management Card**

Card Firmware revision :	EBb3
Card Commercial Reference :	66102
Card Technical Level :	01
Card Revision :	CA
Card Serial Number :	49HF5100H
Card Ethernet Mac Address :	00:06:23:00:1C:68
Card Ethernet Speed :	100 MBit



## 4.2.2 On-line help

On-line contextual help in English is available at the top of each page by clicking on the Help link, which is always located on the top right corner. The navigation menu of the on-line help is identical to that of the card's pages.

The Help page always opens a new window.

### Network Management Card

- UPS**
  - UPS Properties
  - UPS Control
  - Weekly Schedule
  - Shutdown Parameters
- Logs and Notification**
  - Measurements
  - Event Log
  - System Log
  - Email Notification
- Settings**
  - Network
  - System
  - Notified Applications
  - Access Control
  - Time
  - Firmware upload

#### UPS Properties Help

This is the page by default, displaying the fundamentals status of the UPS.

At the top of the page, the UPS is identified : image, name and location.

The alarm icon above the UPS image shows if an alarm is active when it is red, click on it to see the current alarm page. When there is no alarm the green icon is displayed.

The electric diagram of the UPS is displayed showing the electrical flow which powers the load and also the main parts of the UPS.

The electric diagram is not available for Line Interactive UPS.

The second part of the page is refreshing every 10 seconds and contains informations depending of the selection in the combo box :

---

**UPS Status** selects the main status of the UPS :

**Active sources** shows the current use of a modular UPS, the notation  $x$  UPS +  $y$  UPS is meaning :  $x$  is the number of modules necessary to power the load,  $y$  is the number of redundant modules.

**Power source** shows where the power comes from.

**Output load level** shows the load level.

**Output** shows the status of all UPS outputs.

---

**UPS Modules** selects the status of the modules of the UPS, available only for modular UPS :

Each module of the UPS has static informations as the serial number, or dynamic information as the global status showed with an alarm icon and also its percent load and battery level.

### 4.2.3 UPS control

Click on the "UPS Control" section in the menu

The parameters of this menu can only be modified after entering the "Login" and "Password". The following screen is proposed automatically:



The default login and password are: admin/admin

Each field accepts up to 10 characters max.

After the login and password are entered, they remain active for 5 minutes.

If the browser is closed, they will have to be re-entered.

An error in either field results in systematic rejection of the requested action (save, page access, card reboot...).

After three unsuccessful attempts, the browser must be rebooted.

These two fields do not travel "decoded" on the IT network. They are encrypted with an MD5 type algorithm, ensuring total confidentiality.

In case of [password loss](#), the user can return to the default values via the maintenance menu.

UPS configuration may prevent the shutdown and restart commands from being properly run. Read the UPS user manual for more information.

### Network Management Card

**UPS Control** Help

**Pulsar M 2200** Computer Room

Output	Status	Control	Off Delay	Toggle Duration	On Delay
Master	On	Safe power down & reboot		0 sec	
Group1	On	None	0 sec	0 sec	0 sec
Group2	On	None	0 sec	0 sec	0 sec

Execute Save

This page enables triggering of [startup and shutdown sequences](#) for the UPS main output and controlled outlets.

The status of each output is displayed by a symbol associated with the Off label (red symbol) or On (green symbol).

The shutdown sequences take into account the time required for the registered servers to shut down without losing data ([see shutdown parameters](#)).

The main outlet has priority over the controlled outlets. Shutdown of the main outlet causes the controlled outlets to shut down. Controlled outlets can only be started if the master outlet is on.

The Check column proposes six different commands, and a command is only actually started after clicking on **Execute**:

- **Safe power down:** A sequence to switch off output power is launched immediately. The systems supplied are shut down correctly while the shutdown sequence is running, then the output is cut.
- **Safe power down & reboot:** A sequence to switch off then restore output power is launched immediately. The powered systems are shut down correctly during the shutdown sequence, then the output is switched off.
- Finally, the restart sequence is launched at the end of the time delay specified in the "Toggle duration" parameter. The output status is updated.

- **Immediate On:** A sequence to switch on output power is launched immediately. The output is re-powered and the systems supplied start up correctly.
- **Delayed, safe power down:** This is the same switch off sequence as for the "Safe power down" command, but postponed by the number of seconds programmed in the "Off Delay" parameter.
- **Delayed, safe power down & reboot:** This is the same switch off then on sequence as for the "Safe power down & reboot" command, but postponed by the number of seconds programmed in the "Off Delay" parameter.
- **Delayed On:** This is the same switch on sequence as for the "Immediate On" command, but postponed by the number of seconds programmed in the "On Delay" parameter.

The **Save** button saves the Off Delay, Toggle duration and On Delay parameters on the card.

Security: The administrator must click on Save and enter his/her login/password to save modifications or run commands. The default login and password by default are: admin/admin

## 4.2.4 UPS weekly schedule programming

Click on the **Weekly schedule** section of the menu.

**Network Management Card**

UPS		Weekly Schedule		Help
<input type="radio"/> UPS Properties		<b>Pulsar M 2200</b>		<b>Computer Room</b>
<input type="radio"/> UPS Control				
<input checked="" type="radio"/> Weekly Schedule				
<input type="radio"/> Shutdown Parameters				
Logs and Notification				
<input type="radio"/> Measurements				
<input type="radio"/> Event Log				
<input type="radio"/> System Log				
<input type="radio"/> Email Notification				
Settings				
<input type="radio"/> Network				
<input type="radio"/> System				
<input type="radio"/> Notified Applications				
<input type="radio"/> Access Control				
<input type="radio"/> Time				
<input type="radio"/> Firmware Upload				

Day	Shutoff Time	Restart Time
Sunday	-	22:00
Monday	20:00	06:30
Tuesday	-	-
Wednesday	-	-
Thursday	-	-
Friday	-	-
Saturday	-	-

UPS configuration may prevent the shutdown and restart commands from being properly run. Read the UPS user manual for more information.

The weekly schedule enables the administrator to optimise power consumption or program a reboot of the protected equipment at a set time.

In a shutdown sequence, the Network Shutdown Modules connected to the card are informed and ensure that each machine is shut down correctly before the UPS output is switched off. Up to 7 UPS shutdown sequences can be programmed in one week, with a minimum shutdown delay of 30 minutes.

The On / Off sequences are valid only if the card's time has been properly set.

Security: The administrator clicks on "Save" and enters his/her login / password to save any edits. The login and password by default are: admin/admin

## 4.2.5 Shutdown parameters

This page enables viewing and configuration of UPS operating parameters in battery mode and for power restoration.

Click on the **Shutdown parameters** section in the menu to see the list of parameters.

### Network Management Card

UPS	Shutdown Parameters			Help
<ul style="list-style-type: none"> <li>UPS Properties</li> <li>UPS Control</li> <li>Weekly Schedule</li> <li>Shutdown Parameters</li> </ul>	Pulsar M 2200			Computer Room
Logs and Notification	Output	On battery	System Shutdown	Restart
<ul style="list-style-type: none"> <li>Measurements</li> <li>Event Log</li> <li>System Log</li> <li>Email Notification</li> </ul>	Master	<b>Shutdown</b> if Remaining time under: 180 sec if Capacity under: 20 % <input type="checkbox"/> after: 30 min	Shutdown duration : 120 sec	If Capacity exceeds: 15 %
	Group1	<b>Switch Off</b> after: 900 sec if Capacity under: 75 %	Shutdown duration : 120 sec	<b>Switch On</b> after: 30 sec
	Group2	<b>Switch Off</b> after: 1800 sec if Capacity under: 68 %	Shutdown duration : 120 sec	<b>Switch On</b> after: 18 sec
	<input checked="" type="checkbox"/> Show advanced parameters			
	Save modified settings :			<input type="button" value="Save"/>

When you tick the **Show advanced parameters** option, extra parameters are displayed. These parameters enable, in particular, adjustment of certain thresholds related to the percentage of remaining battery charge level.

The Output column enables each outlet to be named (maximum 20 characters).

#### Note

As priority is given to the main outlet, the card cannot supply the controlled outlets when main outlet power is off.

For the main outlet ("Master" by default)

**The first shutdown criteria initiates the restart of the [shutdown sequence](#).**

- **If remaining time is under** (0 to 99999 seconds, 180 by default) is the minimum remaining backup time from which the shutdown sequence is launched.
- **If battery capacity is under** (0 to 100%); this value cannot be less than that of the UPS and is the minimum remaining battery capacity level from which the shutdown sequence is launched.
- **Shutdown after** (0 to 99999 minutes, not validated by default) is the operating time in minutes left for users after a switch to backup before starting the shutdown sequence.
- **Shutdown duration** (120 seconds by default) is the time required for complete shutdown of systems when a switch to backup time is long enough to trigger the shutdown sequences. It is calculated automatically at the maximum of Shutdown duration of subscribed clients but can be modified in the Advanced mode.
- **If battery capacity exceeds** Minimum battery level to reach before restarting the UPS after utility restoration

Important: Certain UPSs do not support this option

**For the controlled outlets ("group 1 or group 2" by default)**

The page enables programming of operation time and level in backup mode to manage outlet load shedding in the event of electric power failure:

- **Switch Off after** (from 0 to 99999, 65535 by default) defines the time during which the outlet is supplied starting from the moment of utility failure. Caution, this time includes the outlet shutdown duration.
- **Switch Off if battery capacity under** (0 by default) is an extra condition for outlet shutdown that can trigger the shutdown sequence before the shutdown duration runs out.
- **Shutdown duration** is the time required for complete shutdown of the systems supplied by the outlet when an outlet shutdown sequence is launched.  
It is calculated automatically using the maximum shutdown durations of notified applications on the outlets.
- **Switch On after** (from 0 to 99999, default 65535) is the period between main output startup and startup of the relevant programmable outlet, therefore outlet startup can be delayed in relation to the main output.

Important: Certain UPSs do not support this option

Security: The administrator has to click on Save and enter his/her login/password to save any modifications. The login and password by default are: admin/admin

## 4.2.6 Measurements

Click on "*Measurements*" in the menu

The next window shows the measurements for a mono phases UPS.

### Network Management Card

The screenshot shows the 'Measurements' window for a 'Pulsar M 2200' UPS. The window title is 'Measurements' and it includes a 'Help' button and a 'Computer Room' label. There are 'Save Log' and 'Clear Log' buttons. The main content is a table with the following columns: Date, Time, AC Normal (Voltage, Frequency), AC Output (Voltage, Frequency, Power (kVA), Load level(%)), and Battery (Capacity(%), Remaining time(mn)).

Date	Time	AC Normal		AC Output				Battery	
		Voltage	Frequency	Voltage	Frequency	Power (kVA)	Load level(%)	Capacity(%)	Remaining time(mn)
2008/06/12	17:56:47	241	50.0	231	50.0	0.1	2	99	125
2008/06/12	17:55:47	241	50.0	232	50.0	0.0	3	99	125
2008/06/12	17:54:47	242	50.0	230	50.0	0.0	2	99	125
2008/06/12	17:53:47	241	50.0	230	50.0	0.0	2	99	125
2008/06/12	17:52:47	241	50.0	231	50.0	0.0	2	99	111
2008/06/12	17:51:47	245	50.0	232	50.0	0.0	2	99	125
2008/06/12	17:50:47	243	50.0	231	50.0	0.0	2	99	125
2008/06/12	17:49:47	243	50.0	230	50.0	0.1	2	99	125
2008/06/12	17:48:47	243	50.0	231	50.0	0.0	2	98	124
2008/06/12	17:47:47	243	50.0	230	50.0	0.0	2	98	124
2008/06/12	17:46:47	243	50.0	231	50.0	0.0	2	98	124
2008/06/12	17:45:47	243	50.0	231	50.0	0.0	2	98	124
2008/06/12	17:44:47	243	50.0	230	50.0	0.0	2	98	124
2008/06/12	17:43:47	243	50.0	230	50.0	0.0	2	98	124
2008/06/12	17:42:47	243	50.0	230	50.0	0.1	2	98	124
2008/06/12	17:41:47	243	50.0	231	50.0	0.1	2	98	124
2008/06/12	17:40:47	243	50.0	231	50.0	0.0	2	98	124

The following measurements are saved and time-stamped (env. 430):

- **AC Normal : Voltage:** Value of the utility voltage supplying the UPS
- **AC Normal : Frequency:** Value of the utility frequency supplying the UPS
- **AC Output : Voltage:** Value of the output voltage of your UPS
- **AC Output : Frequency:** Value of the output frequency of your UPS
- **AC Output : Power (kVA):** Value of the output power of your UPS
- **AC Output : Load level (%):** Value of the percentage of load at UPS output
- **Battery : Capacity (%):** Percentage of charge available in the battery
- **Battery : Remaining time (mn):** Estimation of the remaining backup time

The save frequency of these values is defined in the "[System](#)" page (60 seconds by default). Approximately 435 time-stamps are stored permanently on the card. The oldest time-stamps are automatically deleted.

**Save Log** enables all saved values to be opened or saved in CSV format. (compatible with Excel type spreadsheets)

**Clear Log** enables deletion of all records. Enter the login/password to validate this action.



## 4.2.7 Event log

Click on **Event Log** in the menu

**Network Management Card**

**UPS**

- UPS Properties
- UPS Control
- Weekly Schedule
- Shutdown Parameters

**Logs and Notification**

- Measurements
- **Event Log**
- System Log
- Email Notification

**Settings**

- Network
- System
- Notified Applications
- Access Control
- Time
- Firmware Upload

**Help**

**Event Log**

**Pulsar M 2200** **Computer Room**

Date	Time	Event Description
2008/06/12	18:03:43	UPS on normal AC
2008/06/12	18:03:43	Normal AC OK
2008/06/12	18:03:41	Bypass AC voltage OK
2008/06/12	18:03:41	Normal AC voltage OK
2008/06/12	18:01:11	Bypass AC voltage out of tolerance
2008/06/12	18:01:11	Normal AC voltage out of tolerance
2008/06/12	18:01:10	Outlet group 2 shutdown in 28 mn 00 s
2008/06/12	18:01:10	Outlet group 1 shutdown in 13 mn 00 s
2008/06/12	18:01:10	System shutdown in 1 h 40 mn 20 s
2008/06/12	18:01:09	UPS on battery
2008/06/12	18:01:09	Normal AC NOK

- **Save log** enables all saved values to be opened or saved in CSV format. (compatible with Excel type spreadsheets)
- **Clear log** enables deletion of all records. The administrator must enter his/her login / password to validate this action.

The card can save 435 events. The table of managed alarms is included in the [appendix](#).

## 4.2.8 System log

Click on **System log**. in the menu

**Network Management Card**

**UPS**

- UPS Properties
- UPS Control
- Weekly Schedule
- Shutdown Parameters

**System Log** **Help**

**Pulsar M 2200** **Computer Room**

Date	Time	Event Description
2008/06/13	11:16:05	Environment sensor : Communication failure
2008/06/13	11:15:01	Network Management Card startup
1970/01/01	00:00:00	Time synchronized by NSM or EPM with 2008/06/13 11:13:50 [166.99.224.246]

**Logs and Notification**

- Measurements
- Event Log
- System Log**
- Email Notification

**Settings**

- Network
- System
- Notified Applications
- Access Control
- Time
- Firmware Upload

- **Save log** enables all saved values to be opened or saved in CSV format. (compatible with Excel type spreadsheets)
- **Clear log** enables deletion of all records. The administrator must enter his/her login / password to validate this action.

The card can save 435 events. The table of managed alarms is included in the [appendix](#).

## 4.3 Notification

### 4.3.1 Email Notification

The card offers the possibility of redirecting UPS alarms to an e-mail server. The format of these e-mails is compatible with mobile telephone transfer systems using text messages (SMS).

SMS notification requires the use of a third-party application that converts emails to SMS.

#### Network Management Card

**UPS**

- [UPS Properties](#)
- [UPS Control](#)
- [Weekly Schedule](#)
- [Shutdown Parameters](#)

**Logs and Notification**

- [Measurements](#)
- [Event Log](#)
- [System Log](#)
- [Email Notification](#)

**Settings**

- [Network](#)
- [System](#)
- [Notified Applications](#)
- [Access Control](#)
- [Time](#)
- [Firmware Upload](#)

**Email Notification**
Help

Pulsar M 2200
Computer Room

**Recipient list**

recipient1@domain.com  
 recipient2@domain.com  
 recipient3@domain.com  
 recipient4@domain.com

**Recipient :**

**Attached files :**

- Measurements
- Event Log
- System Log

**Periodic report :** Every  day(s) at:

day of next report:

[Email Message Settings](#)

[Configure SMTP Server on](#)

[Network Settings](#)

**Notified events for the selected Recipient**

**Battery operation**

- UPS on battery
- UPS on normal AC
- UPS Off sequence in progress
- Low battery

**UPS alarms**

- Battery fault
- Battery OK
- UPS overload
- UPS returns to normal load
- UPS fault
- UPS OK
- UPS communication failed
- UPS communication restored
- Charger fault
- Output on by-pass
- Return from by-pass

**Software alarms**

- Firmware upgrade

Network Management Card – User Manual

34003991EN/ED

Page 43/93

### Recipient List:

On the left side of this page, up to four recipients can be configured to receive e-mails from the card. Each addressee has its own trigger events, selected from the right side of the page, for which an e-mail is sent. The card's log indicates e-mail transmission errors.

Each recipient is configured with the following parameters:

- **Recipient:** (Field is limited to 99 characters) this is the e-mail address of the person or department to receive the e-mail.  
The default value is [recipientx@domain.com](mailto:recipientx@domain.com)
- **Attached files:** The files selected (Measurements, Event log, System log, Environment measurements) are enclosed with each e-mail sent. The files are sent in CSV format
- **Periodic report:** In addition to the e-mails sent when events occur, a periodic e-mail containing the 3 log files can be sent to the recipient every x days at the time specified by the user.  
To configure the first transmission, specify the day, time and frequency of the next transmission in the "next report" box. After this date, the page will show the date and time of the next transmission. Data are sent in CSV format.
- **Save:** Saves any modifications.
- **Test:** enables an e-mail to be sent to the recipient immediately. This is one way of checking e-mail transmission, particularly access to the SMTP server configured in "Network" settings. A transmission report is added to the system log.  
The event label in the subject and text of the message is replaced with a test label.  
If the user makes any modifications to the page, they must be saved before using the "Test" function.

### Notified events:

- The right side of the page shows the events that can be notified.  
By default, only the main events of battery operation and a few UPS alarms are accessible. All the events appear if the Show/Hide Events option is actuated.  
By default, two events are selected for notification. The user can modify this pre-selection by ticking other events or can, on the contrary, restore the initial configuration by clicking Set Default.
- **Email Message Settings:** access to the message configuration page
- **Network Settings:** enables the name of the SMTP server to be entered. [See page](#)
- **Security:** The administrator has to click on Save and enter his/her login/password to save any modifications. The default login and password are: admin/admin

### 4.3.2 E-mail Message Settings

This page enables customisation of the content of the messages received by recipients of e-mails sent by the card.

Customisation is common to the four recipients that can be notified (see [E-mail notification](#)).

#### Network Management Card

**UPS**

- UPS Properties
- UPS Control
- Weekly Schedule
- Shutdown Parameters

**Logs and Notification**

- Measurements
- Event Log
- System Log
- Email Notification

**Settings**

- Network
- System
- Notified Applications
- Access Control
- Time
- Firmware Upload

**Email Message Settings** Help

**Pulsar M 2200** Computer Room

These settings are common for all the recipients, which can be notified by E-mail.

**Sender :**

ups@domain.com

**Subject :**

Network Management Card - <Event message>

Network Management Card

UPS Name

UPS Location

Event message

**Message text :**

Type here your own text

Save

- **Sender:** (59 characters maximum) identifies the source of the message. The default value is *ups@domain.com*.  
This field is free. However, depending on the type of SMTP server configuration, it is possible that the server checks that the domain name contained in the Sender address exists, and even that the user in the Sender address belongs to this domain.
- **Subject:** enables the user to specify the subject of the e-mail to be sent. By entering some free text and selecting from several optional fields, if desired, the message subject is built:
  - UPS name recalls the name of the UPS; it may or may not be selected.
  - UPS location recalls the geographic location of the UPS (see System Settings); it may or may not be selected.
  - Event message identifies the event generating the e-mail; it may or may not be selected.
- **Message text** is a free zone long of 255 characters maximum.  
The body of the e-mail sent is composed of:
  - Message text, which is free text.
  - The date and time of the event, as saved in the log.
  - URL of the card, enabling a direct link with the card to be established.

- Attachments, as configured for the e-mail recipients.
- Duplication of the subject, as configured.

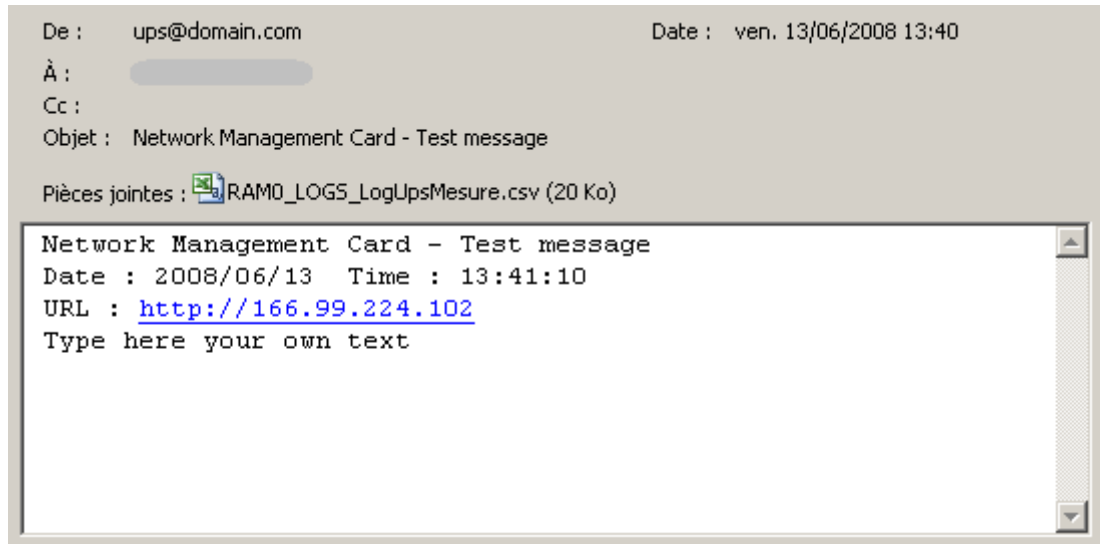

## 4.4 Configuration

The parameters of this menu can only be modified after entering the "Login" and "Password". The following screen is proposed automatically:

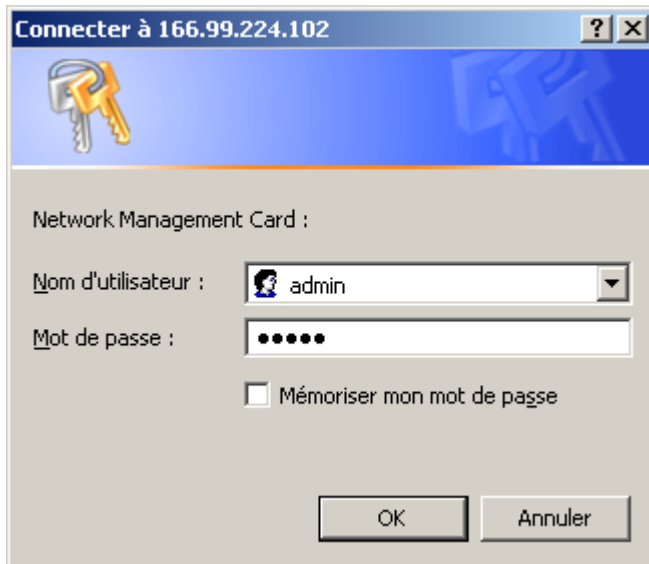

The default login and password are: admin/admin

Each field accepts up to 10 characters max.

After five minutes have elapsed without activity on web page, or if the browser is closed and reopened, you must re-enter the user name and password

An error in either field results in systematic rejection of the requested action (save, page access, card reboot...). After three unsuccessful attempts, the browser must be rebooted.

These two fields do not travel "decoded" on the IT network. They are encrypted with an MD5 type algorithm, ensuring high level of confidentiality.

In the event of [password loss](#), the user can return to the default values via the maintenance menu.

## 4.4.1 Network settings

Click on **Network** in the menu.

This menu enables the administrator to configure the network parameters of the card and authorisation of the remote upgrade of the embedded system.

### Network Management Card

Network Settings		Help
Pulsar M 2200		Computer Room
IP address :	<input type="text" value="166.99.22.252"/>	
Subnet Mask :	<input type="text" value="255.255.255.0"/>	
Gateway Address :	<input type="text" value="166.99.17.1"/>	
Hostname :	<input type="text"/>	
Domain Name :	<input type="text" value="ups.domain.com"/>	
BootP/DHCP :	<input type="button" value="Enabled"/>	
Firmware Upload :	<input type="button" value="Enabled"/>	
Primary DNS Server :	<input type="text" value="151.110.134.13"/>	
Secondary DNS Server :	<input type="text" value="151.110.134.17"/>	
SMTP Server (for Email Notification) :	<input type="text" value="smtpserver"/>	

Save modified settings :

- **IP Address:** The IP address of the card (e.g.: 166.99.22.252).
- **Subnet Mask:** The mask of the sub-network of your network (e.g.: 255.255.255.0).
- **Gateway Address:** Indicate the IP address of the gateway to access the stations located outside the card's subnet . (e.g.: 166.99.17.1).
- **Hostname** must be suited to the card. This is the first part of the fully qualified domain name, used by the DNS.  
As the card does not support NetBIOS protocol, the hostname will only be sent to DNS if the DHCP server sends it the hostname with the new IP address. This mechanism is described in the update of the DNS protocol [RFC 2136](#)
- **Domain Name** is the domain to which the card belongs. This is the part of the fully qualified domain name that follows the hostname and is used by the DNS. The default value of the two parameters comprising the fully qualified domain name: ups.domain.com
- **BOOTP/DHCP:** Authorises (choose "Enabled") configuration of network parameters with your BootP/DHCP server when the card is booted.



Sequence with Bootp/DHCP server: After each startup, the card makes 5 attempts to recover the network parameters. If no response is received from the server, the card boots with the last saved parameters from the previous start. These parameters are those shown on the page.

The default value for this parameter is "Enable"

**Note 1:**

If the hostname is not used, the IP address supplied by the DHCP server must be fixed to maintain connection with the clients installed on the stations to be protected.

**Note 2:**

During the first connection, if the DHCP query is not successful, the NMC starts with the following IP configuration:

**Default IP address: 192.168.1.2**

**Subnet mask: 255.255.255.0**

**Gateway Address: 0.0.0.0**

- **Firmware Upload:** Authorise (chose "Enabled") remote updating of the card's embedded software. The default value for this parameter is "Enabled".
- **Primary DNS Server:** contains the IP address of the main DNS server ensuring conversion of the domain name to IP address.
- **Secondary DNS Server:** contains the IP address of the secondary DNS server ensuring conversion of the domain name to IP address if the primary DNS server is not available.
- **SMTP Server:** contains the name or IP address of the local server with which the card connects to send e-mails.

It may be filled in either as host + domain name (DNS resolution), or directly with the IP address.

The default value is smtpserver. The card uses the standard port (25) for sending e-mails.

Important note:

The card must be rebooted after any changes to these parameters. [See "System" page](#)

Security: The administrator has to click on Save and enter his/her login/password to save any modifications.

## 4.4.2 System

Click on **System** in the menu.

This menu enables the customisation of the information on the [UPS properties](#) pages.

**Network Management Card**

UPS	System Settings	Help
<ul style="list-style-type: none"> <li>● UPS Properties</li> <li>● UPS Control</li> <li>● Weekly Schedule</li> <li>● Shutdown Parameters</li> </ul>	<p><b>Pulsar M 2200</b></p> <p>UPS Contact : <input type="text" value="Computer Room Manager"/></p> <p>UPS Location : <input type="text" value="Computer Room"/></p> <p>Default Language : <input type="text" value="Auto"/></p> <p>History log interval (sec): <input type="text" value="60"/></p> <p>Environment log interval (sec): <input type="text" value="300"/></p> <p>Save modified settings : <input type="button" value="Save"/></p> <hr/> <p style="text-align: center;"><input type="button" value="Reset Communication"/></p> <p><input checked="" type="checkbox"/> Keep TCP/IP parameters <input type="button" value="Factory Reset"/></p>	<p><b>Computer Room</b></p>
<p><b>Logs and Notification</b></p> <ul style="list-style-type: none"> <li>● Measurements</li> <li>● Event Log</li> <li>● System Log</li> <li>● Email Notification</li> </ul>		
<p><b>Settings</b></p> <ul style="list-style-type: none"> <li>● Network</li> <li>● System</li> <li>● Notified Applications</li> <li>● Access Control</li> <li>● Time</li> <li>● Firmware Upload</li> </ul>		

- **UPS Contact:** This text field is limited to 49 characters. Enter the name of the person responsible for UPS administration at IT network level and/or electrical maintenance. This field does not appear on any other Web page. By default, its value is "Computer Room Manager".
- **UPS Location:** Enter a description (limited to 31 characters) of the location of the UPS in your installation (e.g. Computer room E1-C066). This text is displayed in the home page. By default, its value is "Computer Room".
- **Default Language:** Enables initialisation of the browser language at card connection. Choice of one of the available languages: English, French, German, Spanish, Italian, Chinese Traditional, Chinese simplified, Japanese, Russian, Korean changes the language of the html interface pages (reboot the browser after modification).
- **History log interval:** [from 5 to 99999 sec., 60 by default]. Measurement save period.
- **Environment log interval:** [from 60 to 99999 sec., 300 by default]. Temperature and humidity measurement save period.
- **Reset Communication button:** performs a remote reboot of the card without modifying the configuration. This action is compulsory for consideration of any changes made on the "Network Settings" page. Security of this operation is ensured by requesting Login and Password.
- **Factory Reset button:** enables restoration of the default configuration of all the card's parameters. TCP/IP parameters: IP address, subnet mask, gateway and BootP/DHCP value are maintained if the "**Keep TCP/IP parameters**" option is selected. Security of this operation is ensured by requesting Login and Password. The default login and password are: admin/admin.

### 4.4.3 Notified Applications

Click on **Notified Applications** in the menu.

Security: The administrator has to enter his/her login/password in order to view this information.

This menu enables:

- The addition of the supervision stations receiving traps and configuration of the trap type.
- To list all the Notified Applications and the main parameters.
- To test the operation of notified applications by simulating power loss by sending a real shutdown sequence.

#### Network Management Card

**UPS**

- UPS Properties
- UPS Control
- Weekly Schedule
- Shutdown Parameters

**Logs and Notification**

- Measurements
- Event Log
- System Log
- Email Notification

**Settings**

- Network
- System
- **Notified Applications**
- Access Control
- Time
- Firmware Upload

Notified Applications								Help
Pulsar M 2200							Computer Room	
All	Nr	Hostname or IP Address	Application Name	Output	Configuration	Shutdown duration(sec)	Shutdown after(min)	Connected
<input type="checkbox"/>	1	grefrwe8000769	Shutdown Module V3.10	Master	CENTRALIZED	120		
<input type="checkbox"/>	2	GREFRWC9978046	Shutdown Module V3.10	Master	CENTRALIZED	120		

Select the applications to be removed.

---

Select the applications to be tested.

---

Select the Network-Management-System to be modified.

Up to 100 destinations can be managed by the card:

- 35 in TCP connected mode or
- 100 in UDP not connected mode or
- mixed mode: 20 connected and 50 not connected.

Important note: It is not necessary to add the Network Shutdown Modules protecting your servers in this list. These modules subscribe and unsubscribe themselves automatically.

Select an entry in the list to modify the values in the edit zone at the bottom of the page. The table displays the following information:

- **All**: selects all the lines.
- **Nr**: the index where the application is stored into the table.
- **Hostname or Address IP**: By priority, the hostname of the computer is displayed when the IP address can

be converted into a hostname by a DNS server or if the application has been entered as a hostname.

- **Application Name:** Given by the application at subscription time.
- **Output:** number of the UPS output from which the client is powered.
- **Configuration:** shows where the parameters of the Network Shutdown Module come from: Local (coming from the application) or Central (coming from the card).

The [Central shutdown configuration](#) is available by clicking on the **Configuration** link.

- **Shutdown duration:** the shutdown duration necessary to properly shutdown the computer.
- **Shutdown after:** the time available to the user from the power failure until the launch of the shutoff sequence of the UPS and equipment. This parameter is optional.
- **Connected:** This value is set to YES if the notified application connects through TCP protocol.

Many actions are available on this page:

- **Remove:** Depending on the kind of application, the selected ones will definitively disappear from the table as SNMP applications, or they will disappear and automatically re-subscribe as Network Shutdown Module applications.
- **Utility failure Test:** Two alarms, 'Utility failure' and 'Utility restored' spaced 60 seconds apart, will be sent to the applications selected, making sure that the applications can be reached over the network.
- **Shutdown Test:** This test simulates a UPS low battery sequence. It enables an easy check to see if the server protection works correctly.
  - No intervention on the UPS is required.
  - The applications selected will process the simultaneous alarms and perform an actual shutdown sequence.

**WARNING!**

- This test will generate a REAL shutdown sequence of the selected servers on which the Network Shutdown Module application is running.

- **Add NMS:** allows an SNMP trap receiver to be added such as a Network Management System.
- **Modify NMS:** allows an SNMP trap receiver to be modified.

Both buttons open a new window where it is possible to enter the Application name, the Hostname or IP Address, the Trap community and the severity.

## Network Management Card

<b>UPS</b> <ul style="list-style-type: none"><li>UPS Properties</li><li>UPS Control</li><li>Weekly Schedule</li><li>Shutdown Parameters</li></ul>	<b>Network Management System</b> <b>Pulsar M 2200</b> <span style="float: right;"><b>Computer Room</b></span>
<b>Logs and Notification</b> <ul style="list-style-type: none"><li>Measurements</li><li>Event Log</li><li>System Log</li><li>Email Notification</li></ul>	Application Name : <input type="text"/> Hostname or IP address : <input type="text"/> Protocol : SNMP V1
<b>Settings</b> <ul style="list-style-type: none"><li>Network</li><li>System</li><li>Notified Applications</li><li>Access Control</li><li>Time</li><li>Firmware Upload</li></ul>	Trap Community : <input type="text"/> Severity : <input type="text" value="1 - Warning"/>
	<input type="button" value="Cancel"/> <input type="button" value="Save"/>

The default severity value is 1 – Warning

### 4.4.4 Central shutdown configuration

Click on **Notified Applications** in the menu, then **Configuration**.

## Network Management Card

<b>UPS</b> <ul style="list-style-type: none"><li>UPS Properties</li><li>UPS Control</li><li>Weekly Schedule</li><li>Shutdown Parameters</li></ul>	<b>Central shutdown configuration</b> <span style="float: right;"><b>Help</b></span> <b>Pulsar M 2200</b> <span style="float: right;"><b>Computer Room</b></span> This configuration will be used by the Network-Shutdown-Modules, on next connection.
<b>Logs and Notification</b> <ul style="list-style-type: none"><li>Measurements</li><li>Event Log</li><li>System Log</li><li>Email Notification</li></ul>	<b>Shutdown Parameters</b> <input type="checkbox"/> <b>Shutdown after:</b> <input type="text" value="30"/> min <b>Shutdown duration :</b> <input type="text" value="120"/> sec
<b>Settings</b> <ul style="list-style-type: none"><li>Network</li><li>System</li><li>Notified Applications</li><li>Access Control</li><li>Time</li><li>Firmware Upload</li></ul>	<b>Broadcast</b> <ul style="list-style-type: none"><li><input checked="" type="checkbox"/> Administrators</li><li><input checked="" type="checkbox"/> Users</li></ul> <input type="button" value="Save"/>

This page is used to define either the "shutdown" or the "notification" settings used by the Network Shutdown Modules that connects to Network Management Card. These settings are used by the Network Shutdown

Modules if they are in central-configuration mode or if their configuration is not valid.

- **Shutdown duration:** the shutdown duration necessary to properly shutdown the computer.
- **Shutdown after:** the time available to the user from the power failure until the launch of the shutoff sequence of the UPS and equipment. This parameter is optional. Uncheck the box if you wish not to use this parameter.
- **Broadcast :** Sends network notifications to the **Administrators** and **Users** groups on events declared in the server hosting the NSM

If you wish to set up a new configuration for the Network Shutdown Modules already set to "central-configuration mode", proceed as follows:

- Change the Network Shutdown Module parameters in the "Notified Applications" page.
- Click the "Save" button.
- In this page, select the NSMs for which you want to apply the new configuration.
- Press the "Remove" button.
- The NSMs selected will disconnect then reconnect and use the new configuration.

## 4.4.5 Access control

Click on **Access Control** in the menu.

To access this page, the login and password are systematically requested if they have not already been entered. This menu enables configuration of the different parameters enabling secure access to the card via a browser or SNMP.

The screenshot shows the 'Access Control' configuration page for a Powerware 9130 700 UPS. The interface includes a sidebar with navigation options and a main configuration area with the following fields and options:

- UPS:**
  - UPS Properties
  - UPS Control
  - Weekly Schedule
  - Shutdown Parameters
- Logs and Notification:**
  - Measurements
  - Event Log
  - System Log
  - Email Notification
- Settings:**
  - Network
  - System
  - Notified Applications
  - Access Control
  - Time
  - Firmware Upload
- Access Control Configuration:**
  - Powerware 9130 700** (Model)
  - Computer Room** (Location)
  - Enter New Manager Login:** Text field containing 'admin'.
  - Enter New Password:** Password field with masked characters.
  - Confirm New Password:** Password field with masked characters.
  - Security mode:** Radio button selection:
    - Authentication for configuration
    - Full authentication
    - SSL and full authentication
  - SNMP Community Read-Only:** Text field containing 'public'.
  - SNMP Write Enabled
- Save modified settings:** A 'Save' button is located at the bottom right of the configuration area.

- **Enter New Manager Login:** The login user name. This text field (limited to ten characters) enables secure access and modification of pages. Default value is admin.
- **Enter New Password:** This text field (limited to ten characters) enables secure access to Configuration menu pages. Default value is **admin**.
- **Confirm New Password:** Re-enter the new password.
- **Security mode:** Manages the various authentication methods for page access:
  - Authentication for configuration:** Only the configuration pages are protected by login / password
  - Full authentication:** All pages are protected by login / password
  - SSL and full authentication:** All pages are protected by login / password and are only accessible in SSL

SSL Access: When selected, access to the Web interface is made in secure mode (https).

Connections with Network Shutdown Modules stay in standard mode (secure TCP)

SSL Security Implementation:

SSL	→ version 3.0
TLS	→ version 1.0
Method	→ TLS_RSA_WITH_512_MD5
Auth	→ RSA
Key Exchange	→ RSA
Encryption	→ RC4_512

Digest → MD5

Changes take effect after a card reboot

- **SNMP Community Read-Only:** The SNMPv1 Read community name that identifies a sub-group attached to a network manager or a logical entity. The card and the clients must share the same community name to communicate.
- **SNMP Write Enabled:** Enables SNMP write function.  
**SNMP Community Write:** Displays only if SNMP Write is enabled. The SNMPv1 Write community name that identifies a sub-group attached to a network manager or a logical entity. The card and the clients must share the same community name to communicate.
- **Save:** Saves any modifications.



## 4.4.6 Date and time

Click on **Date and Time** in the menu.

This menu enables initialisation of the date and time of the card in three different ways.

The date format is always of year/month/day type

### Network Management Card

The screenshot displays the 'Setting time' configuration page for a Network Management Card. The page is divided into a sidebar menu and a main content area. The sidebar menu includes sections for 'UPS', 'Logs and Notification', and 'Settings'. The 'Settings' section is expanded, showing options for 'Network', 'System', 'Notified Applications', 'Access Control', 'Time', and 'Firmware Upload'. The main content area is titled 'Setting time' and includes a 'Help' link. Below the title, the device model 'Pulsar M 2200' and the location 'Computer Room' are displayed. The 'Current date and time' section shows the current date as 2008/06/13 and the current time as 14:38:44. The 'Setting time' section offers three options: 'Set manually', 'Accept automatic update from NSM or EPM', and 'Synchronize with NTP server'. The 'Set manually' option is selected, and its configuration fields are visible: 'Date (yyyy/mm/dd):' with the value '2008/06/13', 'Time (hh:mm:ss):' with the value '14:38:44', 'Hostname:' with the value 'ntpserver', and 'Time-Zone:' with a dropdown menu showing '(GMT) Casablanca, Greenwich Mean TIME : Dublin, Lisbon, London'. There is also a checkbox for 'European Daylight Savings Time' which is currently unchecked. At the bottom of the page, there is a 'Save modified settings :' label and a 'Save' button.

- **Set manually:** Enables initialisation of the date and time of the card, with the values entered in the Date and Time fields. This update is made after clicking on the **Save** button.  
Maximum drift is +/- 2 min./month
- **Accept automatic update from NSM or EPM:** Enables initialisation of the date and time of the card, with the values provide by the Network Shutdown Modules or the Intelligent Power Management.

- **Synchronize with NTP server:** Enables connection with a time server, either available on the company's internal network or on the Web. This server communicates GMT time. The IP address or hostname of the time server must be entered, and the time zone of your geographic area must then be selected from the list. Connection is made with the server and the date and time are set after clicking on the "Save" button. Time is updated every five hours, thus preventing any drift in the time. After two attempts, if the NTP server is not accessible, the card resends periodic requests. The card uses the NTP protocol (UDP 123 port). The "firewall" must be configured to transmit queries outside the intranet. When ntp could not be contacted, an error message is issued at the top of the web page.

Note 1:

The even the card is used in a UPS supporting time-stamping, the card's time is automatically synchronized with that of the UPS.

Note 2:

After start-up, if the card is in manual mode or if no NTP server was reached, the card initializes at 01/01/1970

## 4.4.7 Firmware upload

Click on **Firmware Upload** in the menu.

This menu enables a new firmware version to be uploaded

### Network Management Card

The screenshot shows the Network Management Card interface. On the left, there is a navigation menu with three sections: **UPS** (containing UPS Properties, UPS Control, Weekly Schedule, and Shutdown Parameters), **Logs and Notification** (containing Measurements, Event Log, System Log, and Email Notification), and **Settings** (containing Network, System, Notified Applications, Access Control, Time, and **Firmware Upload**). The main content area is titled **Firmware Upload** and includes a **Help** link and the text **Pulsar M 2200 Computer Room**. Below this, there is a section for **Firmware to Upload :** with a text input field, a **Parcourir...** button, and an **Upload** button. A warning message states: **WARNING: This action takes a few minutes. Don't click on any button or item during this operation.**

To upload a new version of the card's firmware, select the file to be loaded using the **Browse...** button and click **Upload**.

Do not interrupt the operation before the card displays the following screen:

### Network Management Card

This screenshot shows the same Network Management Card interface as the previous one, but with a success message. The **WARNING** message is replaced by a green message: **SUCCESS : Firmware was successfully written in FLASH. Restart in progress. Wait a few minutes and click on Refresh button.**

## 4.5 Environment Sensor (option)

The environment sensor (66846) is an option that enables temperature and humidity to be measured, and indication of the position of two external contacts. It is connected with a standard network cable to the Card Settings port of the Network Management Card.

The card automatically detects sensor presence. The main menu then displays an additional section "Environment" with the following elements:

- Status
- Configuration
- Log

Important note: To switch the serial port to the configuration mode, just disconnect the cable and [reset the card](#).

### 4.5.1 Characteristics

- Temperature measurement from 0 to 70 °C with +/- 1°C accuracy
- Measurement of humidity from 0 to 100% with +/- 6% accuracy
- Min / max time-stamped function for temperature and humidity
- Choice of temperature readings in Celsius or Fahrenheit
- High and low thresholds, hysteresis and offset adjustable via Web interface
- Possibility of notification of status changes by e-mail, SMS or SNMP trap  
Note: SMS notification requires the use of a third-party application that converts emails to SMS
- Position detection of 2 dry contacts (maximum sensor/contact distance: 20 m)
- Name and status of each configurable contact
- Recording of events and measurements in the card log
- Possibility of shutting down the installation safely if one of the thresholds is exceeded or dry contact status change
- Connection to the Network Management Card by CAT5 straight RJ45 network cables (maximum card/sensor distance: 20m)

## 4.5.2 Environment Status

### Network Management Card

**UPS**

- [UPS Properties](#)
- [UPS Control](#)
- [Weekly Schedule](#)
- [Shutdown Parameters](#)

**Logs and Notification**

- [Measurements](#)
- [Event Log](#)
- [System Log](#)
- [Email Notification](#)

**Settings**

- [Network](#)
- [System](#)
- [Notified Applications](#)
- [Access Control](#)
- [Time](#)
- [Firmware Upload](#)

**Environment**

- [Status](#)
- [Settings](#)
- [Log](#)

**Environment Status** **Help**

**Pulsar M 2200** **Computer Room**

---

**Temperature**

0      **22.5 °C**      70



Min: **20.7** recorded on 2008/06/13 11:10:40  
 Max: **23.2** recorded on 2008/06/13 14:53:42

[Configure thresholds on Environment Settings](#)

---

**Humidity**

0 %      **34.9 %**      100 %



Min: **34.0 %** recorded on 2008/06/13 14:54:54  
 Max: **53.3 %** recorded on 2008/06/13 11:10:40

[Configure thresholds on Environment Settings](#)

---

**Input #1**

2008/06/13 14:47:41      Input #1 open

---

**Input #2**

2008/06/13 14:51:59      Input #2 open

For both measurements, a graduated gauge proposes the following functions:

The cursor indicates the current value.

Two red zones to the left and right represent the high and low thresholds that can be set on the Environment Settings page.

When the measured value enters one of these zones, an alarm can be notified (see Notification parameter in the Environment Settings page).

Time-stamped minimum and maximum temperatures show the extreme values recorded since the last Reset Min/Max, a thin dotted line shows their positions on the gauge.

Min and Max can be forced at any time to the current value by clicking on the Reset Min/Max button.

Calibrate: The sensor is factory-calibrated, but the user can apply an offset to adjust the measurement.

Input #1 and Input #2 show the position of the two contacts acquired by the sensor.

The position is displayed with the parameters entered in the Environment Settings page.

The last status change of each contact is time-stamped.

The Internet browser updates this page every 10 seconds

## 4.5.3 Environment Settings

### Network Management Card

**UPS**

- UPS Properties
- UPS Control
- Weekly Schedule
- Shutdown Parameters

**Logs and Notification**

- Measurements
- Event Log
- System Log
- Email Notification

**Settings**

- Network
- System
- Notified Applications
- Access Control
- Time
- Firmware Upload

**Environment**

- Status
- Settings
- Log

Environment Settings				Help
<b>Pulsar M 2200</b>			<b>Computer Room</b>	
<b>Sensor name:</b>	<input type="text" value="Environment sensor"/>		<b>Notification</b>	<b>System Shutdown</b>
<b>Temperature</b>	High threshold:	<input type="text" value="40"/>	<input type="checkbox"/>	<input type="checkbox"/>
	<input type="button" value="°C"/> Low threshold:	<input type="text" value="5"/>	<input type="checkbox"/>	<input type="checkbox"/>
	Hysteresis:	<input type="text" value="2"/>		
<b>Humidity</b>	High threshold:	<input type="text" value="90"/> %	<input type="checkbox"/>	<input type="checkbox"/>
	Low threshold:	<input type="text" value="5"/> %	<input type="checkbox"/>	<input type="checkbox"/>
	Hysteresis:	<input type="text" value="5"/> %		
<b>Input #1:</b>	<input type="text" value="Input #1"/>	<input type="text" value="closed"/> when closed	<input type="checkbox"/>	<input type="checkbox"/>
		<input type="text" value="open"/> when open	<input type="checkbox"/>	<input type="checkbox"/>
<b>Input #2:</b>	<input type="text" value="Input #2"/>	<input type="text" value="closed"/> when closed	<input type="checkbox"/>	<input type="checkbox"/>
		<input type="text" value="open"/> when open	<input type="checkbox"/>	<input type="checkbox"/>

Show advanced parameters

Save modified settings :

The environment sensor measures temperature, humidity and gives the status of the 2 contacts (used for door, alarms or generator unit).

The temperature and humidity thresholds can be adjusted and can trigger notification and correct shutdown of the protected system.

The Sensor name is the function name given to the sensor, usually it enables location of the sensor.

Temperature: Choose the temperature unit (°C or °F) from the selection box.

High threshold: if this value is exceeded, a notification if enabled. The default value is 40 °C / 104 °F.

Low threshold: If this value is exceeded, a notification if enabled. The default value is 5 °C / 41 °F.

Hysteresis must be set to prevent multiple notifications if temperature fluctuates around a threshold.

The default value is 2 °C / -3.6 °F.

The high alarm disappears when the value drops below the High threshold - Hysteresis value

The low alarm disappears when the value returns above the Low threshold + Hysteresis value

#### Humidity

High threshold: If this value is exceeded, a notification is sent if this is validated. The default value is 90%.

Low threshold: If this value is exceeded, a notification is sent if this is validated. The default value is 5%.  
Hysteresis must be set to prevent multiple notifications if humidity fluctuates around a threshold. The default value is 5%.

The high alarm disappears when the value drops below the High threshold - Hysteresis value

The low alarm disappears when the value returns above the Low threshold + Hysteresis value

Input #1 and Input #2: Enter an identifier corresponding to the acquired contact (e.g.: rack door, air conditioning, generator unit, etc.). Max. length is 28 characters.

when closed and when open: are the names associated to the two contact positions. (e.g.: "open" and "closed" for a door, "On" and "Off" for a generator).

Each status change triggers a notification if enabled.

When the Notification box is enabled, the following functions are activated for each event selected:

- display in the [list of current alarms](#)
- Consideration in the [UPS log](#)
- SNMP trap generation
- notification by e-mail (if the Environment sensor notification option is enabled in the [e-mail notification](#) page)

The list of messages is provided in the [appendix](#)

System shutdown can be triggered for each notification if this option is enabled. If notification is disabled, the Shutdown option cannot be used.

Export settings to file: Enables exportation ("Download" button) and saving of card configuration information.

Import settings from file: Enables selection of a configuration file ("Browse" button) and uploading ("Upload" button) of card configuration information.

Security: The user must be identified to access this page.

## 4.5.4 Log

**Network Management Card**

**UPS**

- UPS Properties
- UPS Control
- Weekly Schedule
- Shutdown Parameters

**Logs and Notification**

- Measurements
- Event Log
- System Log
- Email Notification

**Settings**

- Network
- System
- Notified Applications
- Access Control
- Time
- Firmware Upload

**Environment**

- Status
- Settings
- **Log**

**Help**

**Environment Log Data**

**Pulsar M 2200** **Computer Room**

Date	Time	Temperature (°C)	Humidity (%)
2008/06/13	16:03:53	22.1	35.7
2008/06/13	15:58:45	22.2	35.4
2008/06/13	15:53:36	22.2	36.1
2008/06/13	15:48:27	22.1	35.6
2008/06/13	15:43:18	22.1	36.0
2008/06/13	15:38:10	22.1	35.8
2008/06/13	15:33:01	22.0	35.3
2008/06/13	15:27:52	22.1	35.7
2008/06/13	15:22:43	22.1	35.3
2008/06/13	15:17:35	22.1	35.2
2008/06/13	15:12:26	22.1	35.1
2008/06/13	15:07:17	22.2	34.8
2008/06/13	15:02:08	22.5	34.9
2008/06/13	14:57:00	22.9	34.3
2008/06/13	14:51:51	22.7	36.7
2008/06/13	14:46:42	21.4	36.6

The two environment sensor measurements: Temperature and Humidity are recorded at an interval defined by the Environment log interval in the [System settings](#) page.

By default, this period is 300 seconds.

Each measurement is dated and stored in the log of the UPS's communication card.

The size of log files is limited by a time indexing system.

The user can **Save** the log on his/her workstation at any time, in a CSV format file.

The user can also **Clear** the files contained in the card to reset the log.



## 5 Server protection

### 5.1 Set-up of the shutdown parameters

The protection application: Network Shutdown Module or Netwatch, on protected server boot, subscribes itself automatically to [notified applications](#) list and sends its essential data:

IP Address or hostname of the server on which it is installed: So that the card can inform it of power events.

Time required to shutdown the server (Shutdown Duration, configurable in the "Set-up" menu of each NSM):

The card takes into account the longest shutdown time of all the Network Shutdown Modules subscribed (This is the Shutdown duration of the [Shutdown parameters](#)) page to manage UPS shutdowns without affecting any of Shutdown Modules connected.

During normal operation, the protection application periodically checks its connection with the card.

In case of a major power event, the card sends information to the protection application which reacts according to the situation. (shutdown order, programmed actions, messages to the administrator and to users via the network)

When the server shuts down, the protection application unsubscribes itself from the [notified applications](#).

#### 5.1.1 Shutdown criteria managed by the Network Management Card

During an extended power failure, three criteria may cause the server shutdown procedure to be initiated. If several criteria are selected, (See page [Shutdown parameters](#)), the first criterion encountered will launch the shutdown procedure.

At the end of the shutdown procedure, when all servers have been shut down, the UPS may shut down to avoid unnecessary discharge of its batteries, depending on its configuration.

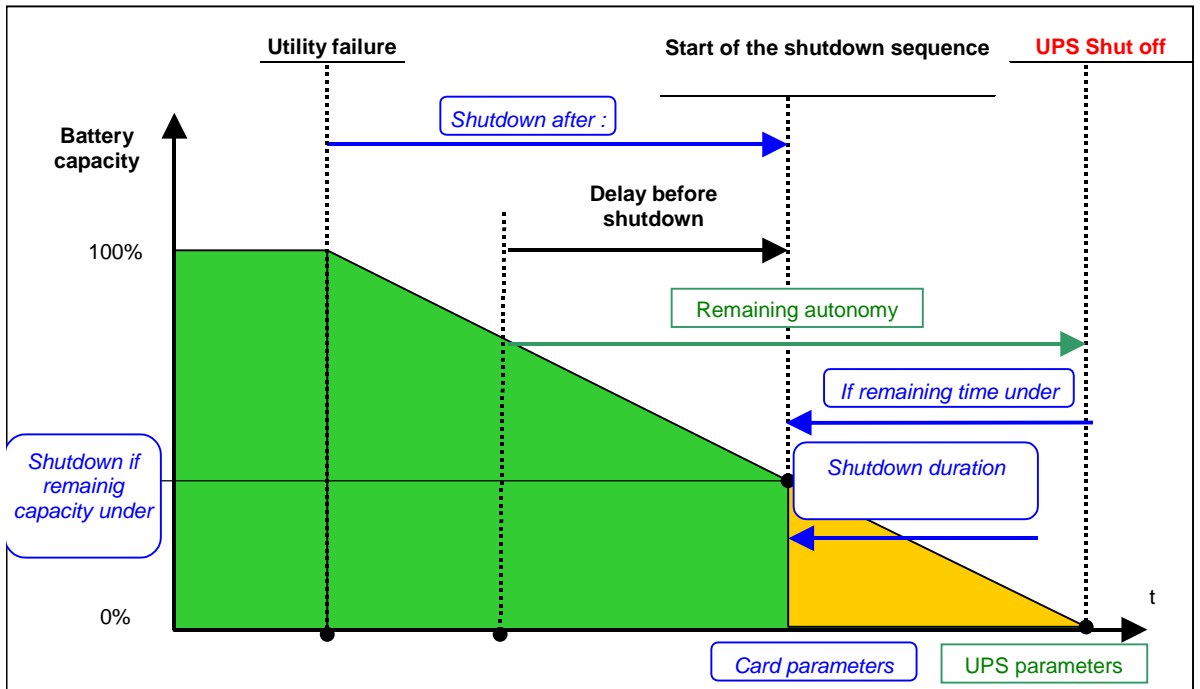

#### 5.1.1.1 Backup time before initiating the shutdown procedure (Shutdown After – Shutdown Timer)

When the UPS switches to battery, the Network Management Card starts the Shutdown Timer countdown and launches the system shutdown procedure at the end of the countdown.

This value must be chosen so that users have time to complete their tasks and disconnect, without exceeding battery backup time.

Note 1:

The Network Shutdown Module can also manage its own Shutdown Timer (configurable in the Shutdown Module "set-up" menu of each Network Shutdown Module) launched when the UPS switches to battery. Note that if this criterion is selected to initiate system shutdown, automatic system reboot when power is restored is not guaranteed (e.g. power restoration if only this system was shut down).

#### 5.1.1.2 Initiating the shutdown procedure when the battery level is lower than: (If Capacity under)

When the card detects that the remaining backup time percentage is less than the configured level, the shutdown sequence is started.

By default, this value is set at 20%.

Note:

The UPS already manages an equivalent parameter for the end of backup pre-alarm.

The card does not accept values less than that programmed in the UPS.

Check the UPS documentation.

#### 5.1.1.3 Shutdown when backup time is less than

When the Network Management Card detects that the percentage of backup time remaining is less than the value set, the shutdown sequence is started.

#### 5.1.1.4 Shutdown duration

Duration (in seconds) required for the system protected by the protection application to shut down.

The protection application send their own "Shutdown duration" to the Network Management Card.

Based on these values (maximum Shutdown duration of all subscribed customer systems) that the card will send to the delayed shutdown order to the UPS.

## 5.1.2 Controlled outlets

Certain UPS models are equipped with controlled outlets (generally 2) which are always dependant on the UPS's main outlet.

Shutdown of the main outlet systematically causes shutdown of the programmable outlets.

The following notations are used to identify these outlets:

Main outlet:	Main
Controlled outlet 1	1
Controlled outlet 2	2

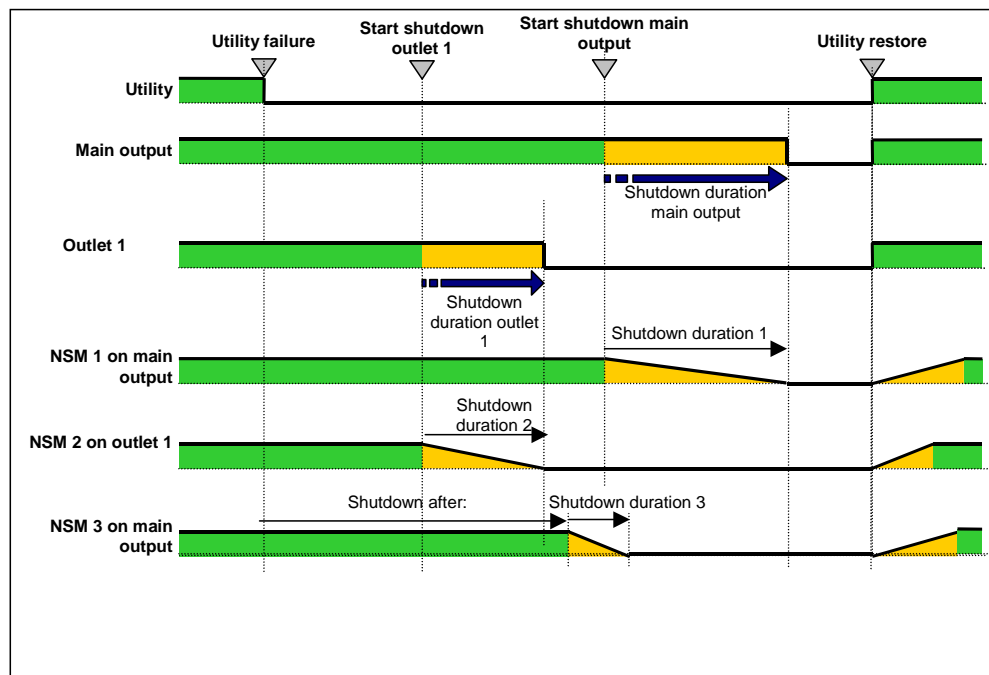

## 5.1.3 Protection of a server connected to a controlled outlet

Network Shutdown Modules (NSM) starting with version 3.0 are compatible with the controlled outlets.

After connecting the server electrically to one of the controlled outlets, the NSM must be informed of the outlet number to which it is connected.

Refer to the documentation of the NSM available on the internet site [www.eaton.com](http://www.eaton.com)

### 5.1.3.1 Load shedding or sequential shutdown

It is possible to optimise backup time by shutting down non-priority equipment or sequencing the shutdown of several devices.

Two shutdown criteria are possible:

- Shutdown of outlets after a set battery back-up time (After)

- Shutdown of outlets at a given battery discharge level (if battery capacity under)

It is possible to specify values for both criteria. The first criterion reached will initiate server shutdown.

### 5.1.3.2 Sequential startup

It is possible to delay outlet power-on to reduce inrush currents on startup or to sequence the startup of several devices.

Controlled outlet startup after a given time is based on startup of the main outlet.

## 5.2 The different server and UPS shutdown sequences

### 5.2.1 Extended power outage, shutdown initiated by the Shutdown Timer (Shutdown after)

During battery backup time, the Shutdown Timer of the Network Management Card is reached: After a user-defined backup time period ([Shutdown parameters](#) page), the shutdown of all servers is initiated, followed by the UPS shutdown (depending on its configuration). The UPS restarts when utility power is restored (depending on its configuration)

Shutdown duration: Maximum value of shutdown times of protection application subscribed to the card. This value is updated each time a client subscribes/ unsubscribes.

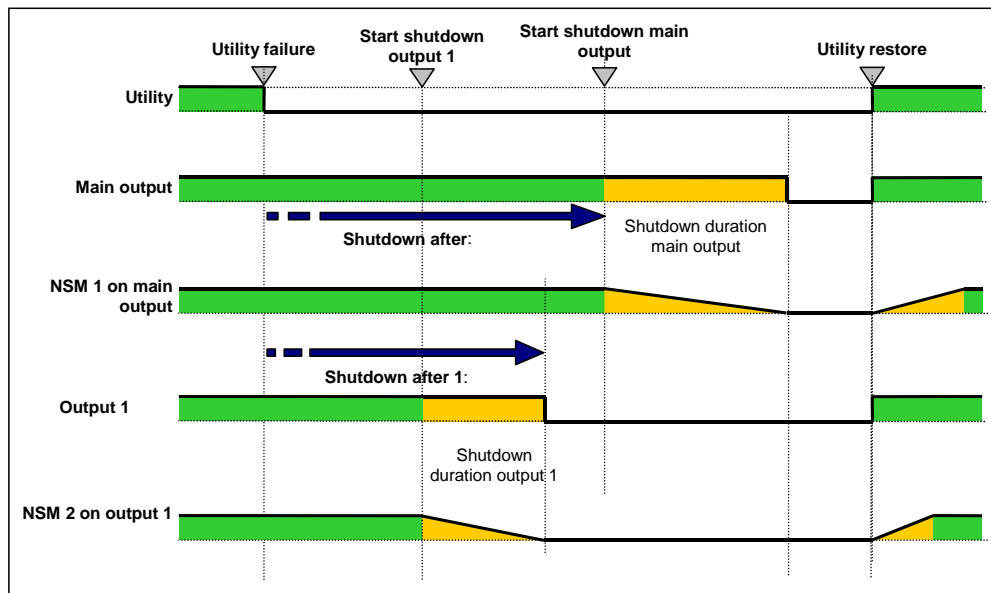

### 5.2.2 Extended power outage, shutdown initiated by the "Low battery power" message

When the "Low battery power" criterion is displayed, the UPS is shut off after taking into account the shutdown duration of the servers.

"Low battery power": The message appears if either of the two following criteria is reached:

- Low Battery Level
- Low Battery Delay

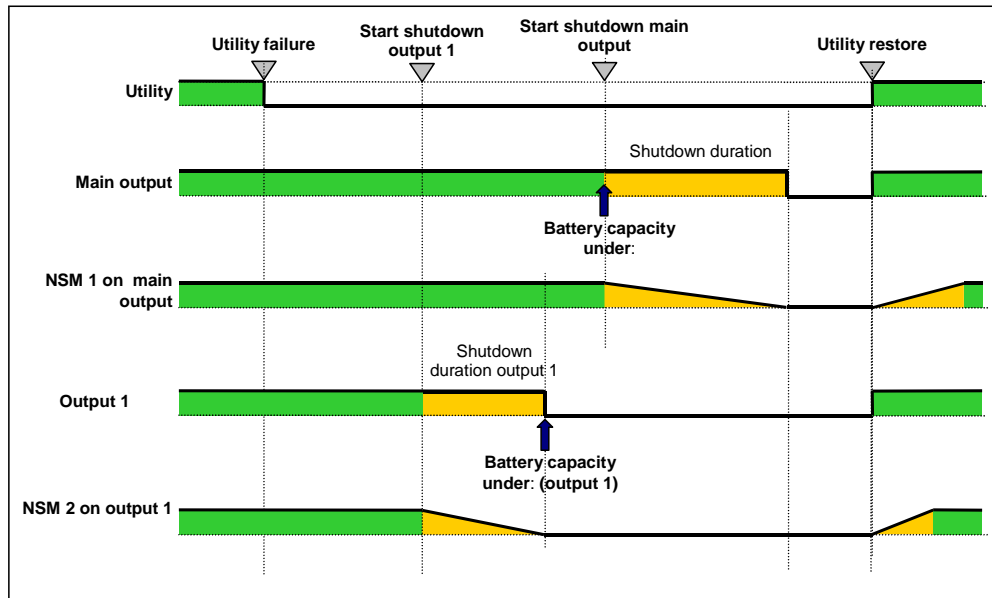

### 5.2.3 Case of power restoration before the end of the "shutdown duration" counter

If power is restored before the end of the Shutdown Duration, the UPS is shut off after the Shutdown Duration for a time equal to the forced reboot delay (10 seconds)

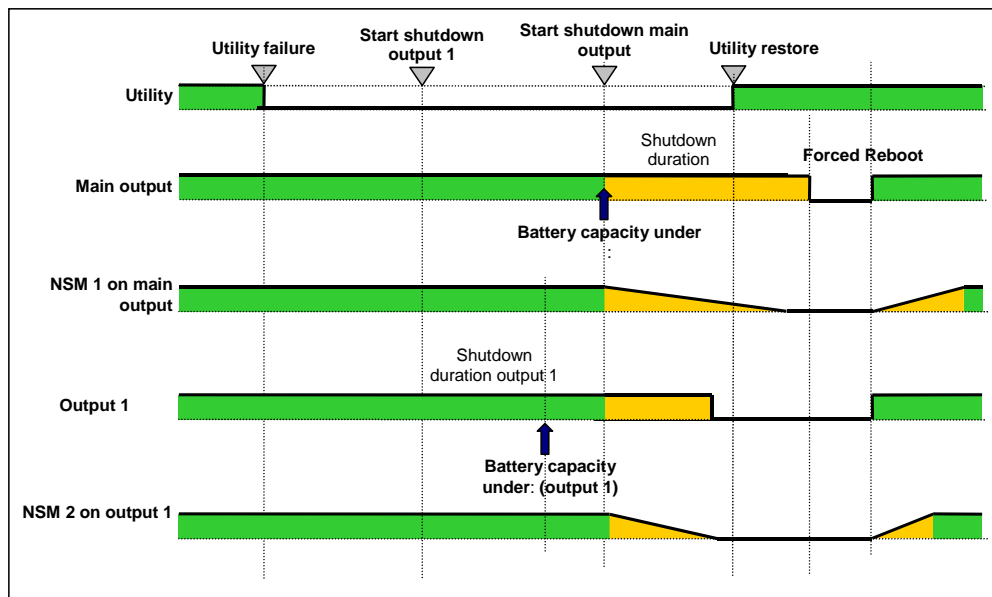

## 5.3 Shutdown management with 2 NMC boards

Certain UPS can have 2 NMC boards in order to:

- Increase the number of protected servers,
- Protect 2 groups of server connected to different networks physically separated.

### 5.3.1 Shutdown Duration

As described in the 5.1.1.4 paragraph, The protection application transmit their own "Shutdown duration" to the Network Management Card. Based on these values (maximum Shutdown duration of all subscribed customer systems) that the card will send to the delayed shutdown order to the UPS.

If the UPS have two NMC cards, the maximum shutdown duration of the two groups of protected systems will be used for the delayed shutdown order.

Example: If the subscribed customers of the first NMC card have a maximum Shutdown duration of 60s and the ones of the second NMC card of 120s, the servers shutdown will be launched 120s before the UPS shutoff..

### 5.3.2 Settings

Set-up shutdown parameters to the same value on the 2 cards is highly recommended (for the main output and the controlled outlets).

If the settings are not the same, the first criteria reached on one the 2 cards will launch the secure shutdown of all servers

Please, note that in any case the shutdown of the protected servers will be executed safely.

## 6 Configuration via RS232

Use the cord supplied with the card.

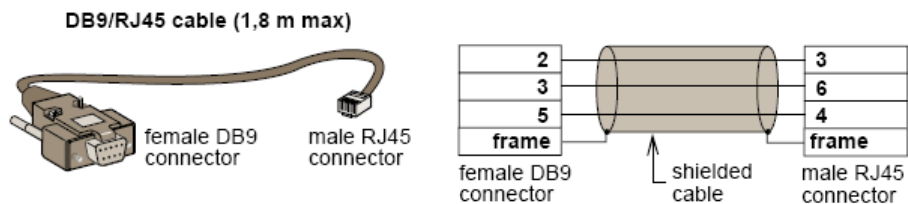

Connect the card to a computer equipped with a hyperterminal type emulator. The serial link must be set at 9600 baud, 8 bits, no parity, 1 stop bit, and without flow control.

Check that UPS power is on.

Enter the admin password (not modifiable).

The menu is in English only.

-----  
EATON

NETWORK MANAGEMENT CARD  
-----

- 1 : Reset
  - 2 : Network configuration
  - 3 : Set Login Password to Default
  - 4 : Return to Default Configuration
  - 0 : Exit
-



## 6.1 Choice 1: Restart / Reset

Use this function to restart the card; two choices are possible

1 : Hardware Reset: Equivalent to a restart of the electrical power supply.

2 : Restart application: Restarts only the application part.

```
-----  
Reset  
-----  
  
1 : Hardware Reset  
2 : Restart application  
0 : Exit  
-----
```

## 6.2 Choice 2: Network Configuration

Use this function to access network settings.

```
-----  
Network settings  
-----  
  
1 : Read Network settings  
2 : Modify Network settings  
3 : Set Ethernet speed  
0 : Exit  
-----
```

### 6.2.1 Choice 1: Read Network settings

Enables reading of the card's routine settings

```
Network configuration :  
MAC address : 00:20:85:FD:1C:07  
Mode : Static IP  
IP address : 166.99.18.129  
Subnet mask : 255.255.248.0  
Gateway : 166.99.17.1
```

## 6.2.2 Choice 2: Modify Network settings

Enables the modification of network parameters

For each of the following questions, you can press <Return> to select the value shown in braces, or you can enter a new value.  
Should this target obtain IP settings from the network?[N]  
Static IP address [166.99.18.129]?  
Subnet Mask IP address [255.255.248.0]?  
Gateway address IP address [166.99.17.1]?  
Wait during your new configuration is saved ...  
Reset the card to take into account the new configuration.

In DHCP mode, the card can receive the following parameters according to the DHCP server settings

- IP address
- Subnet Mask
- Gateway address
- Primary DNS server
- Secondary DNS server

The card must be [restarted](#) in order for the new parameters to be taken into account.

## 6.2.3 Choice 3: Set Ethernet speed

Enables the modification of the network speed

Set the Ethernet speed : [1 : Automatic, 2 : 10 MBit]  
1  
New Ethernet speed : Automatic  
Wait during the new setting is saved ...  
Reset the card to take into account the new configuration.

The card must be [restarted](#) in order for the new parameters to be taken into account.

## 6.3 Choice 3: Lost password / Set Login Password to Default

In the even the login or password is lost, choice 3 enables the return to the default password:

```
-----  
EATON  
NETWORK MANAGEMENT CARD  
-----  
1 : Reset  
2 : Network configuration  
3 : Set Login Password to Default  
4 : Return to Default Configuration  
0 : Exit  
-----  
Wait during Login Password return to default ...
```

Wait for the confirmation message.

```
Login Password are succefully been set.
```

The card is now accessible via the Web with the password admin.

The card must be [restarted](#) in order for the new parameters to be taken into account.

## 6.4 Choice 4: Return to Default Configuration

Enables restoration of the [default configuration](#) of all the card's parameters

```
-----  
EATON  
NETWORK MANAGEMENT CARD  
-----  
1 : Reset  
2 : Network configuration  
3 : Set Login Password to Default  
4 : Return to Default Configuration  
0 : Exit  
-----  
Wait during configuration returns to default ...
```

Wait for the confirmation message.

```
Configuration has been set to default one.  
You must Reset the card.
```

The card must be [restarted](#) in order for the new parameters to be taken into account.

## 7 Appendix

### 7.1 Tables of alarms and events

#### 7.1.1 Table of alarms

List of time dated alarms

##### Alarm on

Battery fuse blown  
No Battery  
Battery temperature fault  
Battery charger fault  
Battery fault  
MAX charger voltage fault  
MIN charger voltage fault  
Charger temperature fault  
Rectifier fault  
Chopper fault  
Normal AC frequency out of tolerance  
Normal AC fuses blown  
Normal AC module fault  
Normal AC voltage out of tolerance  
Normal AC NOK  
Site wiring fault  
Bypass AC frequency out of tolerance  
Bypass AC phase out of tolerance  
Bypass AC voltage out of tolerance  
Automatic Bypass fault  
Automatic Bypass overload  
Automatic Bypass overtemperature  
Automatic Bypass thermal overload  
Automatic Bypass switch (Q4S) open  
Normal AC switch (Q1) open  
Battery switch (QF1) open  
Manual Bypass switch (Q3BP) closed  
UPS on manual bypass  
Output switch (Q5N) open  
Single wave load fault  
Negative DC bus too high

##### Alarm off

Battery fuse OK  
Battery present  
Battery temperature OK  
Battery charger OK  
Battery OK  
Charger voltage OK  
Charger voltage OK  
Charger temperature OK  
Rectifier OK  
Chopper OK  
Normal AC frequency OK  
Normal AC fuses OK  
Normal AC module OK  
Normal AC voltage OK  
Normal AC OK  
Site wiring OK  
Bypass AC frequency OK  
Bypass AC phase OK  
Bypass AC voltage OK  
Automatic Bypass OK  
Automatic Bypass load OK  
Automatic Bypass temperature OK  
Automatic Bypass load OK  
Automatic Bypass switch (Q4S) closed  
Normal AC switch (Q1) closed  
Battery switch (QF1) closed  
Manual Bypass switch (Q3BP) open  
  
Output switch (Q5N) closed  
Load OK  
Negative DC bus OK

Positive DC bus too high	Positive DC bus OK
Negative DC bus too low	Negative DC bus OK
Positive DC bus too low	Positive DC bus OK
Inverter limitation	Inverter end of limitation
Inverter fuses blown	Input fuses OK
Inverter fault	Inverter OK
Inverter overload	Inverter load OK
Inverter over temperature	Inverter temperature OK
Inverter short circuit	Inverter OK
Inverter thermal overload	Inverter load OK
Load not protected - On Automatic Bypass	Load protected - Return from Bypass
Load short circuit	Load OK
Load not powered	Load powered
Protection Lost	Protection OK
Emergency button ON	Emergency button OFF
Fan fault	Fan OK
Redundancy Lost	Redundancy OK
Low battery	Battery OK
UPS communication failed	UPS communication restored
UPS data base not available	UPS data base OK
UPS on battery	UPS on normal AC
UPS internal fault	UPS OK
UPS overload	UPS returns to normal load
UPS overtemperature	UPS temperature OK
Imminent UPS shutoff	UPS OK
<Sensor name>:	<Sensor name>:
Temperature is above high threshold xx °C	Temperature is in normal range
<Sensor name>:	<Sensor name>:
Humidity is above high threshold xx %	Humidity is in normal range
<Sensor name>:	<Sensor name>:
Temperature is below low threshold xx °C	Temperature is in normal range
<Sensor name>:	<Sensor name>:
Humidity is below low threshold xx %	Humidity is in normal range
<Sensor name>: <Input #1 label> <when closed label>	<Sensor name>: <Input #1 label> <when closed label>
<Sensor name>: <Input #1 label> <when open label>	<Sensor name>: <Input #1 label> <when open label>
<Sensor name>: <Input #2 label> <when closed label>	<Sensor name>: <Input #2 label> <when closed label>
<Sensor name>: <Input #2 label> <when open label>	<Sensor name>: <Input #2 label> <when open label>

If the UPS is modular UPS, for each module:

**Battery fuse blown**

No Battery  
Battery temperature fault  
Battery charger fault  
Low battery  
Charger temperature fault  
MAX charger voltage fault  
MIN charger voltage fault  
Chopper fault  
Normal AC fuses blown  
Normal AC module fault  
Inverter fuses blown  
Inverter fault  
Inverter short circuit  
Load short circuit  
Rectifier fuse blown  
Rectifier fault  
DC bus unbalanced  
Emergency button ON  
Load not powered  
UPS internal fault  
Battery fault  
Imminent UPS shutoff  
Normal AC frequency out of tolerance  
Normal AC voltage out of tolerance  
Normal AC switch (Q1) open  
Site wiring fault  
Automatic Bypass switch (Q4S) open  
Bypass AC frequency out of tolerance  
Automatic Bypass fault  
Automatic Bypass overload  
Automatic Bypass overtemperature  
Automatic Bypass thermal overload  
Bypass AC phase out of tolerance  
Bypass AC voltage out of tolerance  
Load not protected - On Automatic Bypass  
Battery switch (QF1) open  
Manual Bypass switch (Q3BP) closed  
UPS on manual bypass

**Battery fuse OK**

Battery present  
Battery temperature OK  
Battery charger OK  
Battery OK  
Charger temperature OK  
Charger voltage OK  
Charger voltage OK  
Chopper OK  
Normal AC fuses OK  
Normal AC module OK  
Input fuses OK  
Inverter OK  
Inverter OK  
Load OK  
Rectifier OK  
Rectifier OK  
Load OK  
Emergency button OFF  
Load powered  
UPS OK  
Battery OK  
UPS OK  
Normal AC frequency OK  
Normal AC voltage OK  
Normal AC switch (Q1) closed  
Site wiring OK  
Automatic Bypass switch (Q4S) closed  
Bypass AC frequency OK  
Automatic Bypass OK  
Automatic Bypass load OK  
Automatic Bypass temperature OK  
Automatic Bypass load OK  
Bypass AC phase OK  
Bypass AC voltage OK  
Load protected - Return from Bypass  
Battery switch (QF1) closed  
Manual Bypass switch (Q3BP) open

Inverter limitation	Inverter end of limitation
Inverter overload	Inverter load OK
Inverter overtemperature	Inverter temperature OK
Inverter thermal overload	Inverter load OK
Negative DC bus too high	Negative DC bus OK
Positive DC bus too high	Positive DC bus OK
Negative DC bus too low	Negative DC bus OK
Positive DC bus too low	Positive DC bus OK
Output switch (Q5N) open	Output switch (Q5N) closed
Normal AC NOK	Normal AC OK
UPS on battery	UPS on normal AC
UPS overload	UPS returns to normal load
UPS overtemperature	UPS temperature OK
Fan fault	Fan OK
UPS communication failed	UPS communication restored

### 7.1.2 Table of UPS events

List of time dated informations

<b>Alarm on</b>	<b>Alarm off</b>
Battery fuse blown	Battery fuse OK
Battery temperature fault	Battery temperature OK
No Battery	Battery present
Battery charger fault	Battery charger OK
Charger temperature fault	Charger temperature OK
MAX charger voltage fault	Charger voltage OK
MIN charger voltage fault	Charger voltage OK
End of Warranty	LCM message OK
End of battery life	LCM message OK
End of life of the wearing parts	LCM message OK
Outlet 1 open	Outlet 1 closed
Outlet 2 open	Outlet 2 closed
Chopper fault	Chopper OK
Normal AC switch (Q1) open	Normal AC switch (Q1) closed
Normal AC frequency out of tolerance	Normal AC frequency OK
Normal AC fuses blown	Normal AC fuses OK
Normal AC module fault	Normal AC module OK
Normal AC voltage out of tolerance	Normal AC voltage OK
Site wiring fault	Site wiring OK
Automatic Bypass switch (Q4S) open	Automatic Bypass switch (Q4S) closed



Bypass AC frequency out of tolerance	Bypass AC frequency OK
Automatic Bypass fault	Automatic Bypass OK
Automatic Bypass overload	Automatic Bypass load OK
Automatic Bypass overtemperature	Automatic Bypass temperature OK
Bypass AC phase out of tolerance	Bypass AC phase OK
Automatic Bypass thermal overload	Automatic Bypass load OK
Load not protected - On Automatic Bypass	Load protected - Return from Bypass
Bypass AC voltage out of tolerance	Bypass AC voltage OK
Battery switch (QF1) open	Battery switch (QF1) closed
Manual Bypass switch (Q3BP) closed	Manual Bypass switch (Q3BP) open
UPS on manual bypass	
Inverter limitation	Inverter end of limitation
Inverter fuses blown	Input fuses OK
Inverter fault	Inverter OK
Inverter overload	Inverter load OK
Inverter overtemperature	Inverter temperature OK
Inverter short circuit	Inverter OK
Inverter thermal overload	Inverter load OK
Output switch (Q5N) open	Output switch (Q5N) closed
Load short circuit	Load OK
Single wave load fault	Load OK
Negative DC bus too high	Negative DC bus OK
Positive DC bus too high	Positive DC bus OK
Rectifier fault	Rectifier OK
Negative DC bus too low	Negative DC bus OK
Positive DC bus too low	Positive DC bus OK
Protection Lost	Protection OK
Redundancy Lost	Redundancy OK
Normal AC NOK	Normal AC OK
Low battery	Battery OK
UPS communication failed	UPS communication restored
UPS data base not available	UPS data base OK
UPS on battery	UPS on normal AC
Emergency button ON	Emergency button OFF
Fan fault	Fan OK
Load not powered	Load powered
UPS internal fault	UPS OK
Battery fault	Battery OK
UPS overload	UPS returns to normal load
UPS overtemperature	UPS temperature OK
Imminent UPS shutoff	UPS OK

< Sensor Name> : Temperature is above high threshold <xx> (°C) or (°F)

<Sensor Name> : Temperature is in normal range

< Sensor Name> : Humidity is above high threshold <xx> (%)

<Sensor Name> : Temperature is in normal range

< Sensor Name> : Temperature is below low threshold <xx> °C or (°F)

<Sensor Name> : Temperature is in normal range

< Sensor Name> : Humidity is below high threshold <xx> (%)

<Sensor Name> : Temperature is in normal range

<Sensor name>: <Input #1 label> <when closed label>

<Sensor name>: <Input #1 label> <when open label>

<Sensor name>: <Input #2 label> <when closed label>

<Sensor name>: <Input #2 label> <when open label>>

### 7.1.3 Table of system alarms

Network Management Card startup
Send test mail SUCCESS
Send test mail ERROR
Send mail to <recipient> ERROR
<Sensor name> Communication failure
<Sensor name> Communication restored
Firmware upgraded
Connected NSM list Full, last connection refused
sendTrap()-> Unable to resolve hostname <hostname>
SNMP Send Trap # <num> failure to <hostname>
Time changed by user with yyyy/mm/dd hh:mm:ss
Time synchronized by NSM or EPM with yyyy/mm/dd hh:mm:ss

## 7.2 SNMP objects

### 7.2.1 IETF Mib

The Card implements the full IETF standard UPS MIB (RFC 1628), including the IETF alarm table. The IETF traps are not sent. Visit <http://tools.ietf.org> for a description of the MIB. The UPS MIB access path is 1.3.6.1.2.1.33

### 7.2.2 EATON Pulsar MIB (ex MGE)

This section contains an overview of MIB definitions for each of the MIB files:

- Eaton Pulsar MIB (MGE MIB)
- Eaton Pulsar MIB (MGE MIB) for environmental sensors

The NMC implements the reduced Eaton Pulsar MIB (MGE MIB), only the objects listed in the following tables are managed. The entire MIB description is available at <http://download.mgeops.com>

The Eaton Pulsar MIB access path is 1.3.6.1.4.1.705.1.

MIB object	SNMP Format	Add.path
upsmgIdentFamilyName	String	{1.1.0}
upsmgIdentModelName	String	{1.2.0}
upsmgIdentFirmwareVersion	String	{1.4.0}
upsmgIdentSerialNumber	String	{1.7.0}
upsmgConfigLowBatteryTime	seconds	{4.7.0}
upsmgConfigLowBatteryLevel	%	{4.8.0}
upsmgConfigAutoRestart	1(yes) 2(no)	{4.9.0}
upsmgConfigVARating	VA	{4.12.0}
upsmgBatteryRemainingTime	seconds	{5.1.0}
upsmgBatteryLevel	%	{5.2.0}
upsmgBatteryVoltage	deciVolts	{5.5.0}
upsmgBatteryCurrent	deciAmps	{5.6.0}
upsmgBatteryFaultBattery	1(yes) 2(no)	{5.9.0}
upsmgBatteryReplacement	1(yes) 2(no)	{5.11.0}
upsmgBatteryLowBattery	1(yes) 2(no)	{5.14.0}
upsmgBatteryChargerFault	1(yes) 2(no)	{5.15.0}
upsmgBatteryLowCondition	1(yes) 2(no)	{5.16.0}
upsmgInputPhaseNum		{6.1.0}
mginputVoltage_1	DeciVolts	{6.2.1.2.1.0}
mginputVoltage_2	DeciVolts	{6.2.1.2.2.0}
mginputVoltage_3	DeciVolts	{6.2.1.2.3.0}
mginputFrequency_1	DeciHz	{6.2.1.3.1.0}
mginputFrequency_2	DeciHz	{6.2.1.3.2.0}
mginputFrequency_3	DeciHz	{6.2.1.3.3.0}
mginputMinimumVoltage		{6.2.1.4.0}

mginputMaximumVoltage		{6.2.1.5.0}
mginputCurrent_1	DeciAmps	{6.2.1.6.1.0}
mginputCurrent_2	DeciAmps	{6.2.1.6.2.0}
mginputCurrent_3	DeciAmps	{6.2.1.6.3.0}
upsmgInputBadStatus		{6.3.0}
upsmgInputLineFailCause		{6.4.0}
upsmgOutputPhaseNum		{7.1.0}
mgoutputPhaseIndex_1		{7.2.1.1.1.0}
mgoutputPhaseIndex_2		{7.2.1.1.2.0}
mgoutputPhaseIndex_3		{7.2.1.1.3.0}
mgoutputVoltage_1	deciVolts	{7.2.1.2.1.0}
mgoutputVoltage_2	deciVolts	{7.2.1.2.2.0}
mgoutputVoltage_3	deciVolts	{7.2.1.2.3.0}
mgoutputFrequency_1	deciHz	{7.2.1.3.1.0}
mgoutputFrequency_2	deciHz	{7.2.1.3.2.0}
mgoutputFrequency_3	deciHz	{7.2.1.3.3.0}
mgoutputLoadPerPhase_1	%	{7.2.1.4.1.0}
mgoutputLoadPerPhase_2	%	{7.2.1.4.2.0}
mgoutputLoadPerPhase_3	%	{7.2.1.4.3.0}
mgoutputCurrent_1	deciAmps	{7.2.1.5.1.0}
mgoutputCurrent_2	deciAmps	{7.2.1.5.2.0}
mgoutputCurrent_3	deciAmps	{7.2.1.5.3.0}
upsmgOutputOnBattery	1(yes) 2(no)	{7.3.0}
upsmgOutputOnByPass	1(yes) 2(no)	{7.4.0}
upsmgOutputUtilityOff	1(yes) 2(no)	{7.7.0}
upsmgOutputInverterOff	1(yes) 2(no)	{7.9.0}
upsmgOutputOverLoad	1(yes) 2(no)	{7.10.0}
upsmgOutputOverTemp	1(yes) 2(no)	{7.11.0}
upsmgAgentIpAddress		{12.1.0}
upsmgAgentSubnetMask		{12.2.0}
upsmgAgentDefGateway		{12.3.0}
upsmgAgentType		{12.6.0}
upsmgAgentMibVersion		{12.11.0}
upsmgAgentFirmwareVersion		{12.12.0}
upsmgAgentCommUPS	1(yes) 2(no)	{12.13.0}

This table lists objects that are managed if there is an optional Sensor / Environmental Monitoring Probe (EMP) installed. The Eaton Pulsar MIB access path is 1.3.6.1.4.1.705.1.

upsmgEnvironAmbientTemp	0.1 degré	{8.1.0}
upsmgEnvironAmbientHumidity	0.1 %	{8.2.0}
upsmgEnvironmentNum		{8.6.0}
upsmgEnvironmentIndex		{8.7.1.1.1}
upsmgEnvironmentComFailure	1(yes) 2(no)	{8.7.1.2.1}
upsmgEnvironmentTemperature	0.1 degré	{8.7.1.3.1}
upsmgEnvironmentTemperatureLow	1(yes) 2(no)	{8.7.1.4.1}
upsmgEnvironmentTemperatureHigh	1(yes) 2(no)	{8.7.1.5.1}
upsmgEnvironmentHumidity	0.1 %	{8.7.1.6.1}
upsmgEnvironmentHumidityLow	1(yes) 2(no)	{8.7.1.7.1}
upsmgEnvironmentHumidityHigh	1(yes) 2(no)	{8.7.1.8.1}
upsmgEnvironmentInput1State	closed(1), open(2)	{8.7.1.9.1}
upsmgEnvironmentInput2State	closed(1), open(2)	{8.7.1.10.1}

### 7.2.3 TRAPS table: (1.3.6.1.4.1.705.1.11)

SNMP traps are sent when alarms appears and disappears.

Level 1:informational, 2:major, 3:critical

MIB TRAP	Trap #	Level
upsmgBatteryFault	Trap 1	Level 3
upsmgBatteryOK	Trap 2	Level 1
upsmgAtLowBattery	Trap 5	Level 3
upsmgFromLowBattery	Trap 6	Level 1
upsmgChargerFault	Trap 7	Level 3
upsmgChargerOK	Trap 8	Level 1
upsmgOnBattery	Trap 11	Level 2
upsmgReturnFromBattery	Trap 12	Level 1
upsmgOnByPass	Trap 13	Level 2
upsmgReturnFromByPass	Trap 14	Level 1
upsmgUtilityFailure	Trap 17	Level 2
upsmgUtilityRestored	Trap 18	Level 1
upsmgOverLoad	Trap 21	Level 3
upsmgLoadOK	Trap 22	Level 1
upsmgOverTemperature	Trap 23	Level 3
upsmgTemperatureOK	Trap 24	Level 1
upsmgOffToStart	Trap 29	Level 2
upsmgOffInProgress	Trap 31	Level 3
upsmgCommunicationFailure	Trap 37	Level 3
upsmgCommunicationRestored	Trap 38	Level 1
upsmgRedundancyLost	Trap 65	Level 2
upsmgRedundancyOK	Trap 66	Level 2
upsmgProtectionLost	Trap 67	Level 2
upsmgProtectionOK	Trap 68	Level 2

If the Environment Sensor is detected, the following information is managed:

upsEnvironmentComFailure	Trap 53	Level 2
upsEnvironmentComOK	Trap 54	Level 2
upsEnvironmentTemperatureLow	Trap 55	Level 2
upsEnvironmentTemperatureHigh	Trap 56	Level 2
upsEnvironmentTemperatureOK	Trap 57	Level 2
upsEnvironmentHumidityLow	Trap 58	Level 2
upsEnvironmentHumidityHigh	Trap 59	Level 2
upsEnvironmentHumidityOK	Trap 60	Level 2

upsEnvironmentInput1Closed	Trap 61	Level 2
upsEnvironmentInput1Open	Trap 62	Level 2
upsEnvironmentInput2Open	Trap 64	Level 2
upsEnvironmentInput2Closed	Trap 63	Level 2

The level is used to select traps to be sent to the supervisor. This adjustment is available from the “Notified applications” page

## 7.2.4 EATON Powerware MIB

The Card implements the full Eaton Powerware MIB (PowerMIB), including alarm tables. The Eaton traps are sent. The Eaton Powerware MIB access path is 1.3.6.1.4.1.534.

Table is an abbreviated list of objects from the PowerMIB. The UPS output/load segment controls objects and the entire MIB description is available at <http://powerquality.eaton.com/Support/SoftwareDrivers>.

MIB Object	SNMP Format	Add.path
xupsIdentManufacturer	String	{1.1.0}
xupsIdentModel	String	{1.2.0}
xupsIdentSoftwareVersion	String	{1.3.0}
xupsIdentOemCode	Integer	{1.4.0}
xupsBatTimeRemaining	Seconds	{2.1.0}
xupsBatVoltage	Volts DC	{2.2.0}
xupsBatCurrent	Amps DC	{2.3.0}
xupsBatCapacity	Percent	{2.4.0}
xupsBatteryAbmStatus	Integer	{2.5.0}
xupsBatteryLastReplacedDate	String	{2.6.0}
xupsInputFrequency	0.1 Hertz	{3.1.0}
xupsInputLineBads	Integer	{3.2.0}
xupsInputNumPhases	Integer	{3.3.0}
xupsInputTable		{3.4.0}
xupsInputPhase	Integer	{3.4.1.1.x}
xupsInputVoltage	RMS Volts	{3.4.1.2.x}
xupsInputCurrent	RMS Amps	{3.4.1.3.x}
xupsInputWatts	Watts	{3.4.1.4.x}
xupsInputSource	Integer	{3.5.0}
xupsDualInputStatus	Integer	{3.6.0}
xupsSecondaryInputWatch	Integer	{3.7.0}
xupsOutputLoad	Percent	{4.1.0}



xupsOutputFrequency	0.1 Hertz	{4.2.0}
xupsOutputNumPhases	Integer	{4.3.0}
xupsOutputTable		{4.4.0}
xupsOutputPhase	Integer	{4.4.1.1.x}
xupsOutputVoltage	RMS Volts	{4.4.1.2.x}
xupsOutputCurrent	RMS Amps	{4.4.1.3.x}
xupsOutputWatts	Watts	{4.4.1.4.x}
xupsOutputSource	Integer	{4.5.0}
xupsBypassFrequency	0.1 Hertz	{5.1.0}
xupsBypassNumPhases	Integer	{5.2.0}
xupsBypassTable		{5.3.0}
xupsBypassPhase	Integer	{5.3.1.1.x}
xupsBypassVoltage	RMS Volts	{5.3.1.2.x}
xupsEnvAmbientTemp	Degrees C	{6.1.0}
xupsEnvAmbientLowerLimit	Degrees C	{6.2.0}
xupsEnvAmbientUpperLimit	Degrees C	{6.3.0}
xupsEnvAmbientHumidity	Percent	{6.4.0}
xupsEnvRemoteTemp	Degrees C	{6.5.0}
xupsEnvRemoteHumidity	Percent	{6.6.0}
xupsEnvNumContacts	Integer	{6.7.0}
xupsContactSenseTable	table	{6.8.0}
xupsContactIndex	Integer	{6.8.1.1.x}
xupsContactType	Integer	{6.8.1.2.x}
xupsContactState	Integer	{6.8.1.3.x}
xupsContactDescr	String	{6.8.1.4.x}
xupsEnvRemoteTempLowerLimit	Degrees C	{6.9.0}
xupsEnvRemoteTempUpperLimit	Degrees C	{6.10.0}
xupsEnvRemoteHumidityLowerLimit	Percent	{6.11.0}
xupsEnvRemoteHumidityUpperLimit	Percent	{6.12.0}
xupsAlarmTable	table	{7.2.0}
xupsAlarmID		{7.2.1.1.x}
xupsAlarmDescr		{7.2.1.2.x}
xupsAlarmTime		{7.2.1.3.x}
xupsOnBattery		{7.3.0}
xupsLowBattery		{7.4.0}
xupsUtilityPowerRestored		{7.5.0}

xupsReturnFromLowBattery		{7.6.0}
upsOutputOverload		{7.7.0}
xupsInternalFailure		{7.8.0}
xupsBatteryDischarged		{7.9.0}
xupsInverterFailure		{7.10.0}
xupsOnBypass		{7.11.0}
xupsBypassNotAvailable		{7.12.0}
xupsOutputOff		{7.13.0}
xupsInputFailure		{7.14.0}
xupsBuildingAlarm		{7.15.0}
xupsShutdownImminent		{7.16.0}
xupsOnInverter		{7.17.0}
xupsBreakerOpen		{7.20.0}
xupsAlarmBatteryBad		{7.23.0}
xupsOutputOffAsRequested		{7.24.0}
xupsDiagnosticTestFailed		{7.25.0}
xupsCommunicationsLost		{7.26.0}
xupsUpsShutdownPending		{7.27.0}
xupsAlarmTestInProgress		{7.28.0}
xupsAmbientTempBad		{7.29.0}
xupsLossOfRedundancy		{7.30.0}
xupsAlarmTempBad		{7.31.0}
xupsAlarmChargerFailed		{7.32.0}
xupsAlarmFanFailure		{7.33.0}
xupsAlarmFuseFailure		{7.34.0}
xupsPowerSwitchBad		{7.35.0}
xupsModuleFailure		{7.36.0}
xupsOnAlternatePowerSource		{7.37.0}
xupsAltPowerNotAvailable		{7.38.0}
xupsNoticeCondition		{7.39.0}
xupsRemoteTempBad		{7.40.0}
xupsRemoteHumidityBad		{7.41.0}
xupsAlarmOutputBad		{7.42.0}
xupsAlarmAwaitingPower		{7.43.0}
xupsOnMaintenanceBypass		{7.44.0}
xupsTestBatteryStatus	Integer	{8.2.0}
xupsLastGeneralTest	Integer	{8.3.0}
xupsLastGeneralTestResult	Integer	{8.4.0}

xupsConfigOutputVoltage	RMS Volts	{10.1.0}
xupsConfigInputVoltage	RMS Volts	{10.2.0}
xupsConfigOutputWatts	Watts	{10.3.0}
xupsConfigOutputFreq	0.1 Hertz	{10.4.0}
xupsConfigDateAndTime	String	{10.5.0}
xupsConfigLowOutputVoltageLimit RMS Volts		{10.6.0}
xupsConfigHighOutputVoltageLimit RMS Volts		{10.7.0}
xupsConfigInstallDate	String	{10.8.0}
xupsTopologyType	Integer	{13.1.0}
xupsTopoMachineCode	Integer	{13.2.0}
xupsTopoUnitNumber	Integer	{13.3.0}
xupsTopoPowerStrategy	Integer	{13.4.0}

## 8 Glossary

### **Bootp:**

Protocol based on UDP used to allocate an IP address corresponding to an Ethernet card during the startup phase. Defined by the RCF 951

### **Community name:**

Access key to access SNMP agent information

### **DHCP** Dynamic Host Configuration Protocol

This IETF protocol enables remote, automatic, self-configuration of the IP addresses of a workstation.

### **DNS** Domain Name Service

The DNS protocol ensure correspondence between the name of a machine and its IP address

### **Gateway**

Interconnection equipment between networks with different conventions, to enable communication between them

### **HTML**

(HyperText Markup Language) Language used to describe hypertext pages on the web.

### **HTTPS:**

Secure version of HTTP, the communication protocol of the World Wide Web. It was invented by Netscape Communications Corporation to provide authentication and encrypted communication and is used in electronic commerce.

### **MIB** MANAGEMENT INFORMATION BASE

- Group of software commands to control and administrate a device through the network. Each type of device (server, hub, PC, UPS, etc.) has its own MIB

### **NETWORK MANAGEMENT CARD**

Communication cards to supervise UPS and communicate with Network Shutdown Module to insure power protection on servers

### **NETWORK MANAGEMENT PROXY**

Communication software installed on a PC connected to the UPS to supervise it and communicate with Network Shutdown Module to insure power protection on servers

### **NMS** NETWORK MANAGEMENT STATION (SNMP)

The dedicated PC or workstation is used on the company's networks to administrate all devices connected to the

network. Data are transmitted using the SNMP protocol. Popular NMS systems include HP OpenView, IBM Tivoli, CA Unicenter, etc.

**NSM: NETWORK SHUTDOWN MODULE**

Protection software installed on a PC or server to protect it

**NTP Network Time Protocol**

Network protocol that synchronizes the time on several machines.

**Programmable outlet** (controlled outlet):

Outlet that can be remote-switched on or off. UM-Client components enable management of such outlets.

**REBOOT:** To restart a system after an interruption.

– To perform an obstacle-free “reboot”, it is essential that the system is correctly and carefully shut down beforehand.

– The reboot is usually automatic if the computer is re-supplied with electricity (from the utility or from the UPS).

**RFC**

Request for Comments. All documents defining internal Internet operation.

**SNMP (SIMPLE NETWORK MANAGEMENT PROTOCOL)**

Protocol used to remote-supervise, administrate and control devices connected to a company network.

**SMTP (SIMPLE MAIL TRANSFER PROTOCOL)**

Enables message transfer between e-mail servers or between the client and its server. It is based on the server's port 25. It is described in RFC 821

**SSL (Secure Sockets Layers)** is a protocol developed by Netscape Communications Corporation for securing data transmission in commercial transactions on the Internet. Using public-key cryptography, SSL provides server authentication, data encryption, and data integrity for client/server communications

**Subnet mask:**

Mask of bits used to identify and differentiate the network address and the equipment address in an IP address. Normally, the mask is automatically determined by the class of address, which defines in a unique manner the network part/equipment part division of the IP address.

- Class A: internet address: 255.0.0.0.

- Class B: internet address: 255.255.0.0.

- Class C: internet address: 255.255.255.0.

**Trap (SNMP):** This term describes an event that affects a MIB variable. Traps are sent to the manager, which is programmed to perform specific tasks upon reception of the traps.