

# PALLET TRUCK SCALES

**TPWLK**  
“LOGISTIC”



**TPWA**  
“ACTIVITY”



**TPWP**  
“PROFESSIONAL”



**TPWI**



**TPWN09**  
“NETWORK”



**USER MANUAL**

## INDEX

|  |    |
|--|----|
| INTRODUCTION.....  | 3  |
| <b>PALLET TRUCK SCALE</b>  |    |
| !! WARNING !! .....  | 4  |
| 1. TECHNICAL SPECIFICATIONS.....   | 5  |
| 2. DIMENSIONS.....   | 5  |
| 3. OPERATING INSTRUCTION.....  | 6  |
| 4. REFERENCE DRAWINGS.....   | 7  |
| 5. POWER SUPPLY AND START UP .....   | 9  |
| <b>INDICATOR</b>   |    |
| 6. FRONT PANEL KEYS AND INDICATORS (5 key version) .....                                       | 10 |
| 7. FRONT PANEL KEYS AND INDICATORS (17 key version) .....                                      | 12 |
| 8. SYMBOLS ON THE LCD DISPLAY .....  | 14 |
| 9. BASIC FUNCTIONS .....   | 16 |
| 9.1 ZERO SCALE.....  | 16 |
| 9.2 TARE OPERATIONS .....  | 16 |
| 9.3 LIMITATION OF THE TARE FUNCTIONS .....   | 17 |
| 9.4 AUTO POWER OFF FUNCTION .....  | 17 |
| 9.5 LOW BATTERY WARNING .....  | 18 |
| 9.6 "TILT" DEVICE .....  | 18 |
| 9.7 MULTI RANGE FUNCTIONING (for legal for trade approved instruments) .....                   | 18 |
| 9.8 REMOTE CONTROL (OPTIONAL) .....  | 19 |
| 9.8.1 STAND-BY FUNCTION.....   | 19 |
| 9.9 DATE/TIME ADJUSTMENT (OPTIONAL).....   | 19 |
| 9.10 "SCREEN SAVER" FUNCTION (OPTIONAL OR INCLUDED DEPENDING ON THE MODEL) .....               | 20 |
| 9.11 PRINTING .....  | 20 |
| 9.12 REENABLING THE PRINTOUTS AND THE INDICATOR FUNCTIONS .....                                | 21 |
| 9.13 DISPLAY OF METRIC DATA (inFo).....  | 21 |
| 10. ADDITIONAL FUNCTIONS OF THE 17-KEY INDICATOR .....   | 22 |
| 10.1 STORED TARE MEMORY VALUES.....  | 22 |
| 10.2 ENTERING THE IDENTIFICATION CODE .....  | 22 |
| 10.3 KEYBOARD LOCK.....  | 23 |
| 10.4 REPETITION OF THE LAST PRINTOUT MADE .....  | 23 |
| 11. SELECTABLE OPERATING MODES .....   | 23 |
| 11.1 UNIT OF MEASURE/POUNDS CONVERSION (Std) .....   | 24 |
| 11.2 NET/GROSS SWITCH (ntGS).....  | 24 |
| 11.3 SET POINT ON THE GROSS WEIGHT (StPG).....   | 24 |
| 11.4 SET POINT ON THE NET WEIGHT (StPn) .....  | 25 |
| 11.5 INPUT/OUTPUT (inout).....   | 25 |
| 11.6 SINGLE - MULTISCALE REPEATER (MAStr) .....  | 26 |
| 11.7 ALIBI MEMORY (ALibi) (OPTIONAL).....  | 28 |
| 11.8 +/- TOLERANCE CHECK (ChEck).....  | 31 |
| 11.9 SAMPLE WEIGHT PERCENTAGE (PErC).....  | 33 |
| 11.10 SINGLE SCALE REPEATER (rPE).....   | 34 |
| 11.11 DISPLAY WITH SENSITIVITY X 10 (ViSS) (TO BE USED IN TESTING DURING THE CALIBRATION)..... | 34 |
| 11.12 HOLD: FREEZING THE WEIGHT ON THE DISPLAY (hLd) .....                                     | 34 |
| 11.13 WEIGHT PEAKS DETECTION (PEAk) .....  | 35 |
| 11.14 HORIZONTAL TOTALIZER (Sum of lots) (tot 0) .....   | 35 |
| 11.15 VERTICAL TOTALIZER (Sum by recipe) (tot S) .....   | 37 |
| 11.16 PIECE COUNTING (Coun).....   | 37 |
| 12. INDICATOR CONNECTED TO PRINTER, FUNCTIONING BY BATTERY .....                               | 38 |
| 13. INSTRUMENT MESSAGES WHILE IN USE .....   | 39 |
| DECLARATION OF CONFORMITY .....  | 41 |
| WARRANTY .....   | 41 |

## INTRODUCTION

This manual contains all the instructions for use and all information necessary for the correct operation of the weighing system.

In thanking you for the acquisition of this weight system, we want to call to your attention some aspects of this manual:

- This booklet supplies useful instructions for the correct operation and maintenance of the weighing system to which it refers; it is therefore necessary to pay the utmost attention to all the paragraphs which illustrate the most simple and secure way to operate;
- This booklet must be considered an integral part of the pallet truck scale and must be included with the deed of sale;
- Neither this publication, nor part of it, can be reproduced without written authorization on the part of the manufacturing firm;
- All of the information reported herein is based on data available at the moment of printing; the manufacturing firm reserves the right to carry out modifications to its own products at any moment, without notice and without any sanction. It is therefore suggested to always verify possible updates.
- Some functions written in the sections regarding the weight indicator might not be available, because these depend on the type of weighing system that has been purchased.

**PS: The person responsible for the use of the pallet truck scale must make sure that all of the safety rules in force in the country of its use should be applied, to guarantee that the equipment is used in conformity with the use for which it is destined and avoid any dangerous situation for the user.**

**The manufacturing firm declines any responsibility derivable from possible errors of weighing.**

**The 6V rechargeable battery has to be completely recharged (12 hours) in the first installation of the instrument; we RECOMMEND disconnecting the battery if the instrument is not going to be used for more than 30 days.**

**In order to avoid the deterioration of the rechargeable battery:**

**In standard conditions:**

- never leave the battery partially or completely uncharged; at least once a week recharge it completely .

**In case the instrument is not used for a long period, one needs to:**

- completely recharge the battery before the system is switched off for the last time.
- recharge completely every 3 months.

### NOTE FOR THE USER:

**Please take note that when the "TECH.MAN.REF." is mentioned, this refers to the Technical Manual which may be obtained from the Reseller.**



The crossed-out wheeled bin on the product means that at the product end of life, it must be taken to separate collection or to the reseller when a new equivalent type of equipment is purchased. The adequate differentiated refuse collection in having the product recycled, helps to avoid possible negative effects on the environment and health and supports the recycling of the materials of which the equipment is made. The unlawful disposal of the product by the user will entail fines foreseen by the current regulations.

# PALLET TRUCK SCALE

## !! WARNING !!

1. This pallet truck scale has been designed to only weigh on pallets
2. Never exceed maximum load, see the weight indicator's label
3. Do not use in an environment with any risk of explosion.
4. Load only when forks are in the lowest position.
5. Check that the pallet truck scale is in good operating conditions.
6. To get the best weighing results, lift up the forks about 5-10 cm.
7. Do not expose the weighting indicator to atmospheric agents ( rain, sun, etc. ).
8. All the connections of the indicator have to be made respecting the rules applicable in the zone and in the installing environment
9. Read and understand all instructions
10. In case of approved scale, the weighing has to be done on a EUR-EPAL 800x1200mm pallet (ref. Norms UIC 435-2 and UIC 435-4).

**FIX THE LOAD ON THE PALLET, AS SHOWN IN THE DRAWING**

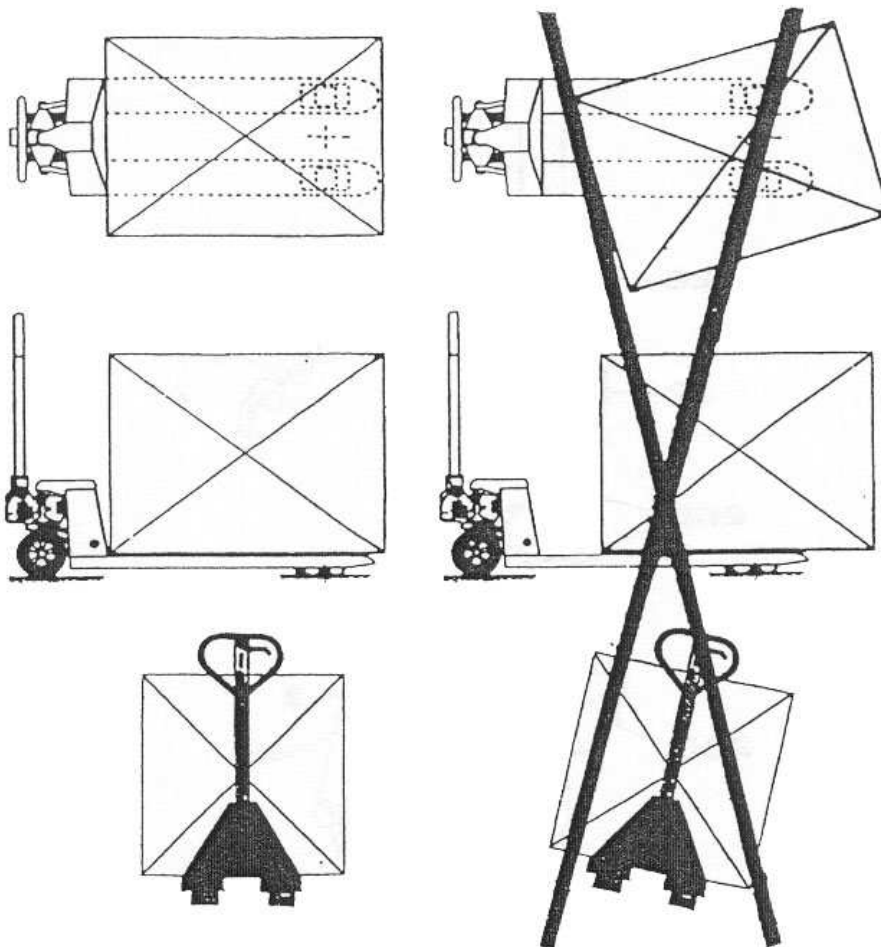

## 1. TECHNICAL SPECIFICATIONS

|                              |  |
|------------------------------|--|
| POWER SUPPLY                 | Rechargeable battery (6 V – 4,5 Ah).   |
| MAXIMUM POWER                | 5 VA   |
| OPERATING TEMPERATURE        | From -10 to +40 °C   |
| DISPLAYED DIVISIONS          | 10000e, 3X3000e for legal for trade use expandable to 800.000 for internal use (with <b>minimum</b> signal coming from the 1,6mV/V cell).  |
| MINIMUM VOLTAGE PER DIVISION | 0.3 μV (approved instrument); 0.03 μV (non approved instrument).   |
| RESOLUTION IN CALCULATION    | 1'500'000 points (with signal in input equal to 3mV/V).  |
| KEYBOARD                     | Water resistant polycarbonate membrane keys with tactile and acoustic feedback.  |
| TARE FUNCTION                | Available on entire range.   |
| AUTO POWER OFF               | Programmable from 1 to 255 minutes, or disinserted.  |
| LOW BATTERY WARNING          | "LoW Batt " will appear on display.  |
| BATTERY RECHARGE TIME        | 12 hours.  |
| LOAD CELL POWER SUPPLY       | 5Vdc ± 5%, 120mA   |
| SERIAL OUTPUTS               | 4 cells: TPWA, TPWLK, TPWI, TPWN09, TPWP.<br>1 RS232/TTL input/output configurable for connection to PC/PLC or WEIGHT REPEATER.<br>1 RS232 input/output for connection to printer. |
| WEIGHT ACCURACY              | +/- 0.03% of applied load.   |

**THE PARTS OF THE INSTRUMENT CONTAINING DANGEROUS ELECTRICAL TENSION ARE ISOLATED AND INACCESSIBLE TO THE USER UNLESS IT HAS BEEN DAMAGED, OPENED, OR ALTERED.**

## 2. DIMENSIONS

See on [www.diniargeo.com](http://www.diniargeo.com)

### 3. OPERATING INSTRUCTION

A pallet truck scale is an electronic weighing system directly installed on a pallet truck; it must be used on even solid surfaces and driven always in the normal position. Before loading, check the maximum load allowed by the pallet truck scale in use (refer to instruction plate on the side of the pallet truck).

The rudder has a double function, direction control and hydraulic lifting.

**N.B.** Lift up or pull down only when the pallet truck scale is in a standing still position.

#### WEIGHING

In order to obtain correct weighing results, one is required to use the pallet truck scale on a flat surface, lift up the forks about 5-10 cm (see the following "CONTROLS" chapter) and wait for the stability before the weight reading.

#### CONTROLS

The lever on the right side of the rudder can be put in 3 positions, like it shows on the plate "Y" in figure B.

POS. 1 – centre = **TRANSPORT** The rudder is completely free to allow driving control.

POS. 2 – down = **LIFT UP** By moving the lever downward the lifting mechanism is activated. Pushing down the rudder will cause the load to lift up.

POS. 3 – up = **PULL DOWN** By moving the lever upward the load will descend. When the lever is quickly moved upward, a special valve controls the descending speed of the load.

#### MAINTENANCE WARNINGS

Before you perform any service, make sure the pallet truck is in a condition of safety.

Never discharge any residue without taking the necessary environmental precautions.

Only perform the service described in this manual. Maintenance and repair jobs not included in this manual must be performed by authorised personnel only.

Serious injury could result from service or maintenance performed by unqualified personnel.

Never alter the safety level of the machine. Always use identical replacement parts.

Never remove or hide in anyway instruction plates and stickers.

Do not modify the pallet truck.

Do not use inflammable cleaners. Do not use direct jets of water. Do not pour liquids on the indicator.

#### RUDDER ASSEMBLY (figure C)

1. Lock rudder ( 228 ) to hydraulic pump ( 200 ) with screws ( 27 ) that you can find in the box.
2. Lock chain ( 208 ) to lift down pedal ( 50 ). Rotate pedal to simplify the connection.

#### DESCENDING SPEED REGULATION (FIGURE C)

1. Lift up forks to maximum height.
2. Set right lever to POS. 1 ( centre ).
3. Make sure the rudder ( 200 ) is in a vertical position.
4. Unscrew bolt ( 2 ) and turn clockwise the adjustable screw ( 48 ) until the forks **start** to descend.
5. Turn adjustable screw 1 ½ turn counter clockwise, then screw bolt ( 2 ).
6. You should be able to obtain a descending movement from every position of the rudder.

#### OIL LEVEL ( figure D )

Check oil level every 6 months. Only use hydraulic oil. No engine oil or brake oil.

Oil viscosity 30 Cst at 40°C . Quantity 0.3 lt.

With the fork in the lower position follow these steps:

1. Remove cover ( 204 ), o-ring ( 11 ) and cap ( 202 ).
2. If necessary add oil. Maximum filling level is 200mm below top of tank.
3. Turn on the pump to get air out of the hydraulic circuit.
4. Put cap ( 202 ), o-ring ( 11 ) and cover (204 ) back.

**DAILY MAINTENANCE**

To keep the pallet truck scale in good operating condition, **the operator must** perform daily these checkpoints:

- Check overall conditions.
- Check weighing scale.
- Check printer ( if installed ).
- Check pump.
- Check rollers and wheels.

**SCHEDULED MAINTENANCE**

Maintenance performed by qualified personnel only. Make sure to put the pallet truck scale on a flat and solid surface.

- Check that nothing is blocking the rollers.
- Grease rollers and wheels bearings.
- Grease control lever on rudder.
- Check oil every six months. Fill up if necessary with IP46 hydraulic oil.

**N.B.** If oil needs to be replaced, follow the necessary precaution and law requirements for the disposal of the exhausted oil.

- Replace rollers and wheels when necessary.

For any questions or problems check with an Authorised service Centre.

**4. REFERENCE DRAWINGS**

B''

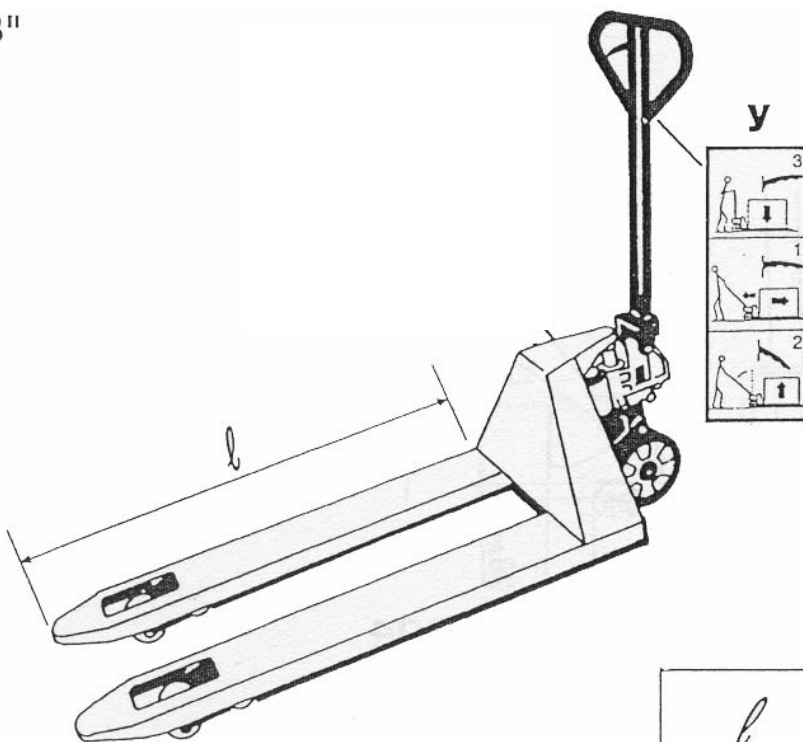

|   |             |
|---|-------------|
| <i>l</i>  | <b>1150</b> |
|  | <b>120</b>  |

C"

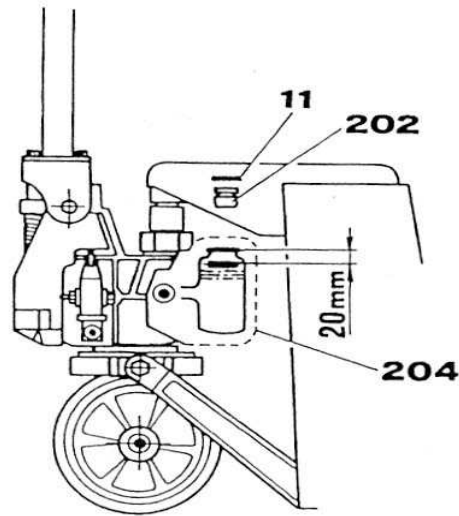

D"

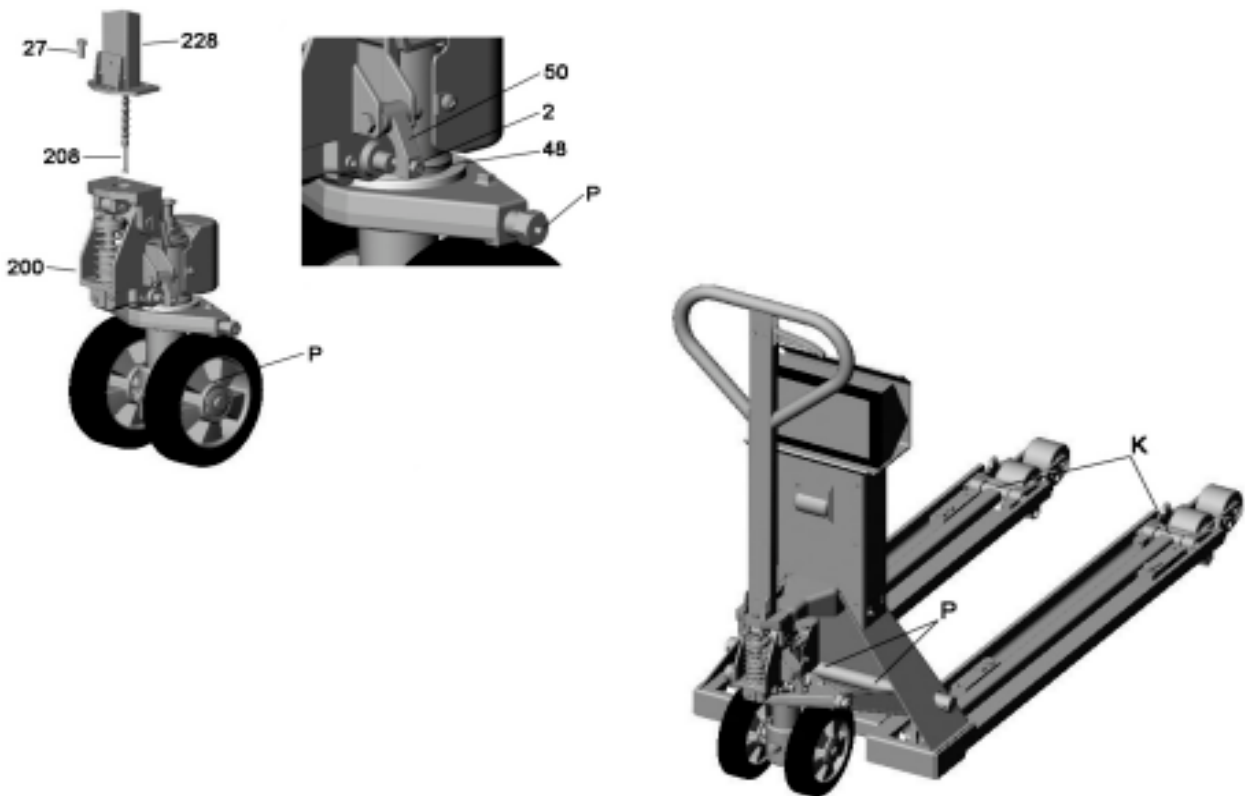

**LUBRICATION POINTS**

Ref. "K" fig. D needs silicon oil for food industry, expiry of 1 month.

Ref. "P" fig. D needs silicon grease for food industry, expiry of 2 months.



## 5. POWER SUPPLY AND START UP

The instruments are powered with a 6Vdc rechargeable internal battery.

It is possible to charge the battery through the 12V power adapter which should be connected to the 230 Vac mains voltage.

Safety norms must be respected for the connection to the mains voltage including the use of a line which has to be free from noise generated by other electronic equipment.

### BATTERY CHARACTERISTICS

Material LEAD

Power 4,5 Ah or 10 Ah

Output 6 V

**THE BATTERY MUST ONLY BE REPLACED WITH AN ORIGINAL FROM THE MANUFACTURER.**

In order **TO CHARGE THE BATTERY** through the 230Vac mains, one should insert the plug end of the AC/DC power adapter into the socket on the column, and the power adapter to your 230Vac current source.

**Do not connect other equipment to the same socket as the one that the adapter is in.**

**Do not step on or crush the power supply cable.**

**TO TURN ON** the instrument press the C key until the indicator turns on; then release.

The display shows:

**XX.YY** is the installed software version.

The instrument turns on all the display segments and symbols

**MAX XXX.XXX** capacity of channel 1

(or **MAStEr** if the "MAStEr" functioning mode has been selected, or **riPE** if the "rEPE" functioning mode has been selected)

**bt XXX** in which XXX is a number from 0 to 100 which indicates the battery level (if present).

The indicator has an "auto zero at start-up" function: in other words it means that if at start-up a weight within +/- 10% of the capacity is detected, it will be zeroed; if the weight is not within this tolerance, with a non approved instrument the display shows the present weight after a few instants, while with an approved instrument "Zero" is shown continuously on the display, until the weight does not re-enter within this tolerance; the auto zero function at start-up may be disabled in the set-up environment (only with non approved instrument); see **SEtuP >> ConFiG >> PArAM >> Auto-0** parameter (**TECH.MAN.REF.**).

By pressing the **ZERO** key for an instant while the version is shown in the LED display, the indicator will show the following in this order:

**MAStEr** if the "MAStEr" functioning mode has been selected or **riPE** if the "rEPE" functioning mode has been selected

**CLoCk** if date and time is detected .

**02.01** in which 02 indicates the instrument type, 01 indicates the metrological software version.

**XX.YY.ZZ** is the installed software version.

**dFW06, dFW06L, dFW06b** or **dFW06d** is the name of the installed software.

**bt XXX** in which XXX is a number from 0 to 100 which indicates the battery level (if present).

**-K- X.YY** in which K identifies the type of keyboard: K=0 5-key keyboard, K=1 17-key keyboard.

X.YY is the installed software version.

After this, it shows the programmed capacity and the minimum division, "hi rES" (in case of NOT approved instrument) or "LEGAL" (in case of approved instrument), the g gravity value, and finally it executes a countdown (self-check).

**TO RESTART** the instrument keep the **C** key pressed for 8 seconds long: the indicator will turn off, then release the key and the indicator will automatically turn on.

**TO TURN OFF** the instrument keep the **C** key pressed until the "- OFF"- " message appears on the display; then release the key.

# INDICATOR

## 6. FRONT PANEL KEYS AND INDICATORS (5 key version)

The front panel of the indicator is designed for quick but simple weighing applications. It consists of a display with 6 digits, 25 mm in height, 7 LED indicators (depending on the model), and a 5 key water-proof film keyboard.

If the indicator has an LCD display, while weighing various multifunction symbols indicating the functioning status will turn on (see section 8 - "SYMBOLS ON THE LCD DISPLAY").

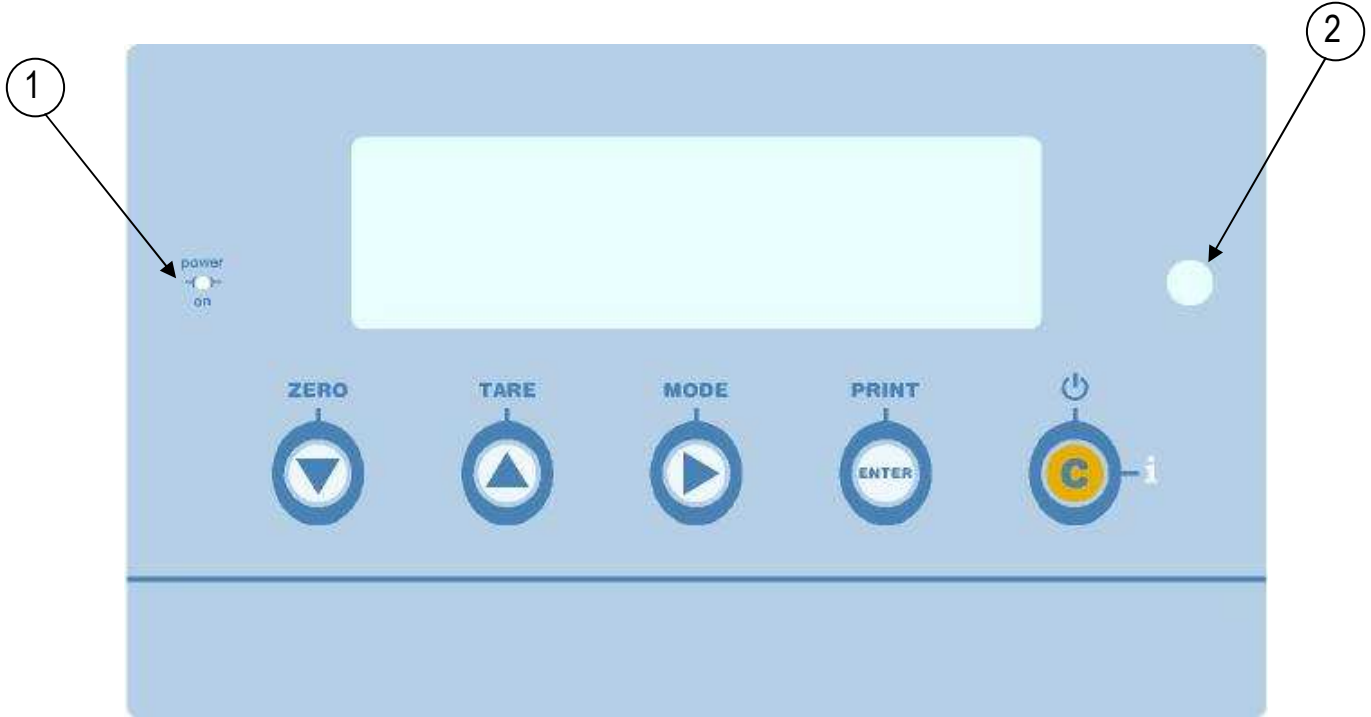

TPWA "ACTIVITY"

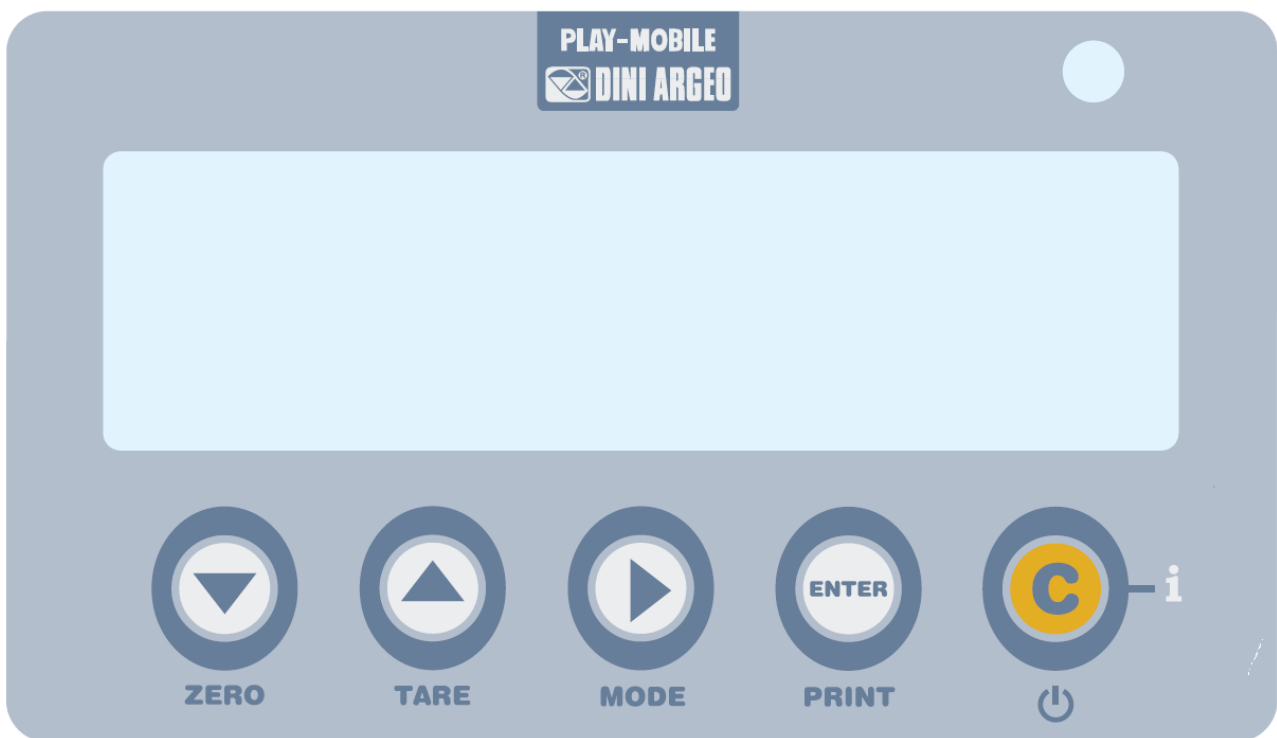

TPWN09 "NETWORK"

| SCALE KEY    | FUNCTION  |
|--------------|---|
| <b>ZERO</b>  | <ul style="list-style-type: none"> <li>- Zeros the displayed gross weight, if it is within +/- 2% of the total capacity.</li> <li>- Cancels the negative tare value.</li> <li>- When entering numbers it decreases the digit to be modified.</li> </ul>   |
| <b>TARE</b>  | <ul style="list-style-type: none"> <li>- If pressed for an instant it carries out the semiautomatic tare.</li> <li>- If pressed at length it allows entering the manual tare from keyboard.</li> <li>- Cancels the negative tare value.</li> <li>- In the numeric input phase it increases the digit to be modified.</li> </ul>   |
| <b>MODE</b>  | <ul style="list-style-type: none"> <li>- It carries out a specific function of the operating mode set in the set-up environment.</li> <li>- In the numeric input phase it selects the digit to be modified, from left to right.</li> </ul>  |
| <b>PRINT</b> | <ul style="list-style-type: none"> <li>- It carries out a specific function of the operating mode set in the set-up environment.</li> <li>- In the numeric input phase, it confirms the entry made.</li> <li>- In the SET-UP, it allows to enter a step or to confirm a parameter within a step.</li> <li>- It transmits the data from the serial port dedicated to the printer.</li> </ul>             |
| <b>C / i</b> | <ul style="list-style-type: none"> <li>- It turns the instrument on and off.</li> <li>- In the numeric input phase, it quickly zeros the present value.</li> <li>- In the SET-UP, it allows to exit a step without confirming the change made in the 5-key indicator.</li> <li>- Allows viewing the scale's metric information: capacity, division, minimum weigh for each configured range.</li> </ul> |

## 7. FRONT PANEL KEYS AND INDICATORS (17 key version)

The front panel of the indicator is designed for quick but simple weighing applications. It consists of an LCD display with 6 digits 25 mm in height, 7 LED indicators (depending on the model) and a water-proof film keyboard with 17 numeric and function keys.

If the indicator has an LCD display, while weighing various multifunction symbols indicating the functioning status will turn on (see section 8 - "SYMBOLS ON THE LCD DISPLAY").

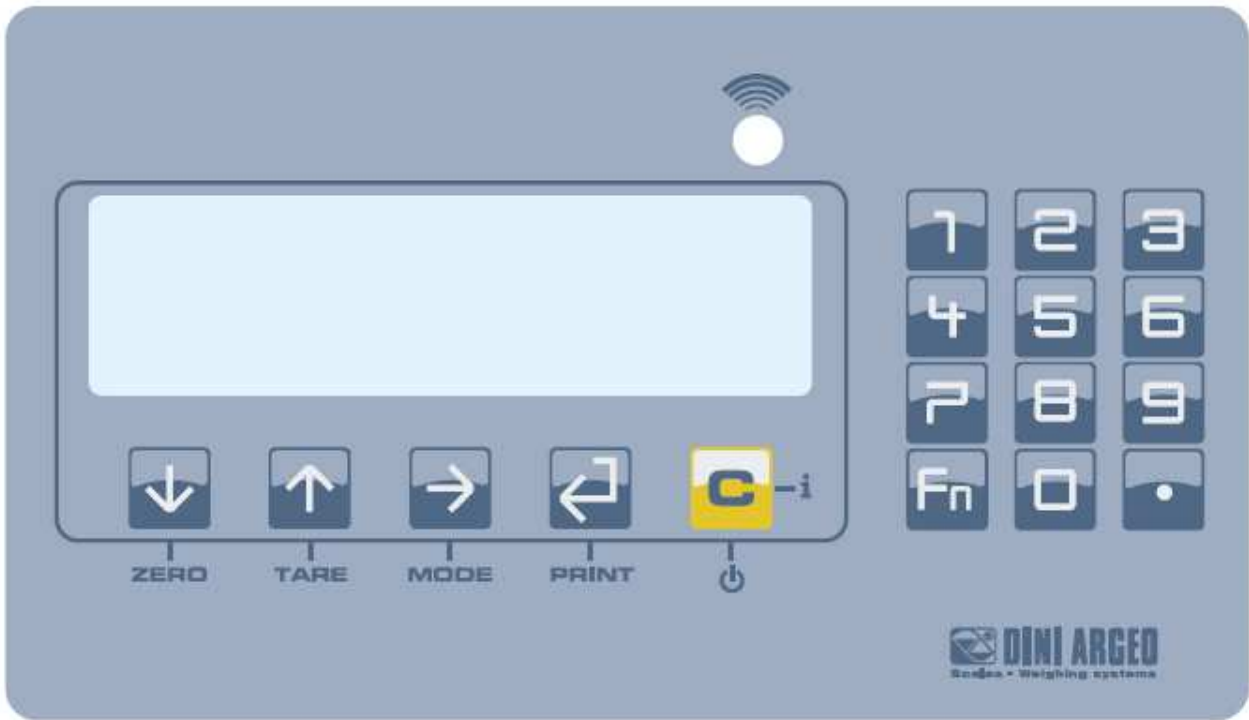

TPWLK "LOGISTIC"

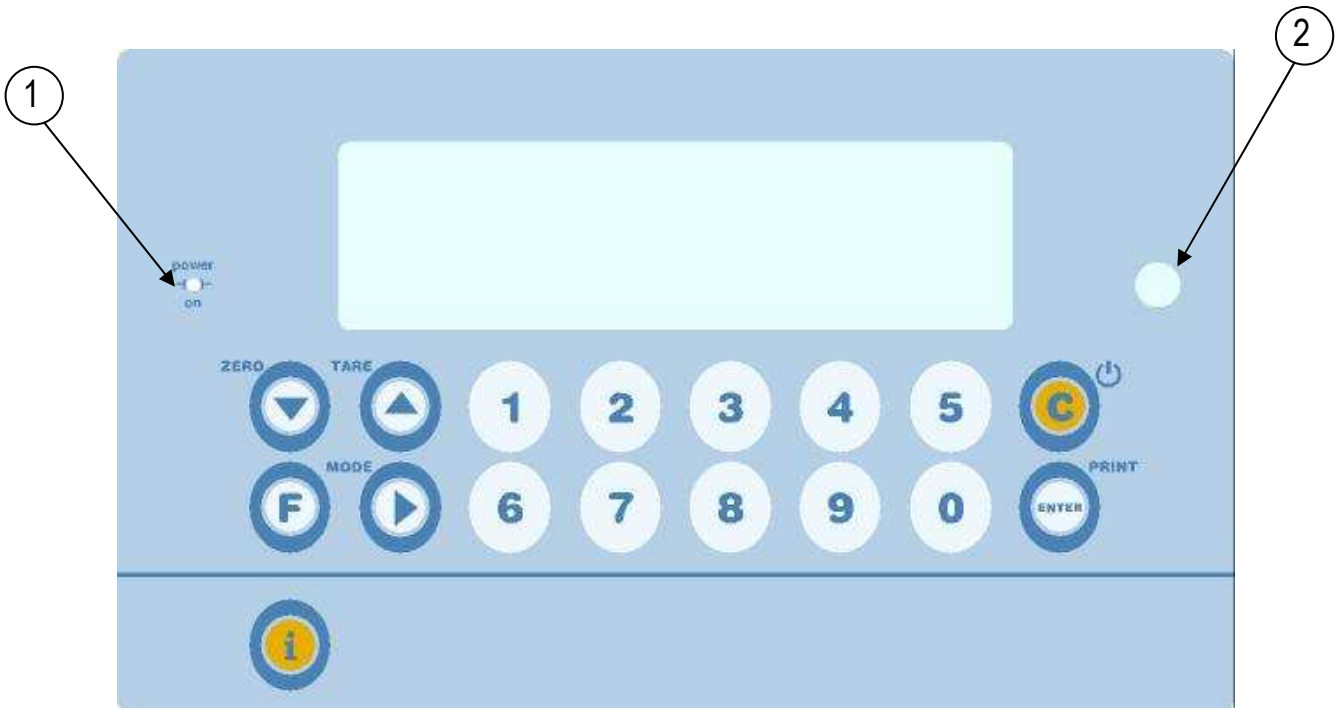

TPWP "PROFESSIONAL" - TPWI

- ① Indicates the presence of the power supply
- ② Sensor for the reception of the infrared signal.

| SCALE KEY               | FUNCTION  |
|-------------------------|---|
| <b>ZERO</b>             | <ul style="list-style-type: none"> <li>- Zeros the displayed gross weight, if it is within +/- 2% of the total capacity.</li> <li>- Cancels the negative tare value.</li> <li>- When entering numbers it decreases the digit to be modified.</li> </ul>   |
| <b>TARE</b>             | <ul style="list-style-type: none"> <li>- If pressed for an instant it carries out the semiautomatic tare.</li> <li>- If pressed at length it allows entering the manual tare from keyboard.</li> <li>- Cancels the negative tare value.</li> <li>- In the numeric input phase it increases the digit to be modified.</li> </ul>   |
| <b>MODE</b>             | <ul style="list-style-type: none"> <li>- It carries out a specific function of the operating mode set in the set-up environment.</li> <li>- In the numeric input phase it selects the digit to be modified, from left to right.</li> </ul>  |
| <b>PRINT</b>            | <ul style="list-style-type: none"> <li>- It carries out a specific function of the operating mode set in the set-up environment.</li> <li>- In the numeric input phase, it confirms the entry made.</li> <li>- In the SET-UP, it allows to enter a step or to confirm a parameter within a step.</li> <li>- It transmits the data from the serial port dedicated to the printer.</li> </ul> |
| <b>C</b>                | <ul style="list-style-type: none"> <li>- It turns the instrument on and off.</li> <li>- In the numeric input phase, it quickly zeros the present value.</li> <li>- In the set-up environment, it allows to exit a step without confirming the change made.</li> </ul>   |
| <b>F / Fn</b>           | <ul style="list-style-type: none"> <li>- It allows to select the desired function; see section 10 - "ADDITIONAL FUNCTIONS OF THE 17-KEY INDICATOR".</li> </ul>  |
| <b>i / .</b>            | <ul style="list-style-type: none"> <li>- Allows to view the scale's metric information: capacity, division, minimum weigh for each configured range.</li> </ul>   |
| <b>NUMERIC KEYBOARD</b> | <ul style="list-style-type: none"> <li>- In the numeric input phase it allows to enter the desired value.</li> </ul>  |

## 8. SYMBOLS ON THE LCD DISPLAY

The LCD display has symbols which show the indicator’s functioning status; you will find the description for each symbol below.

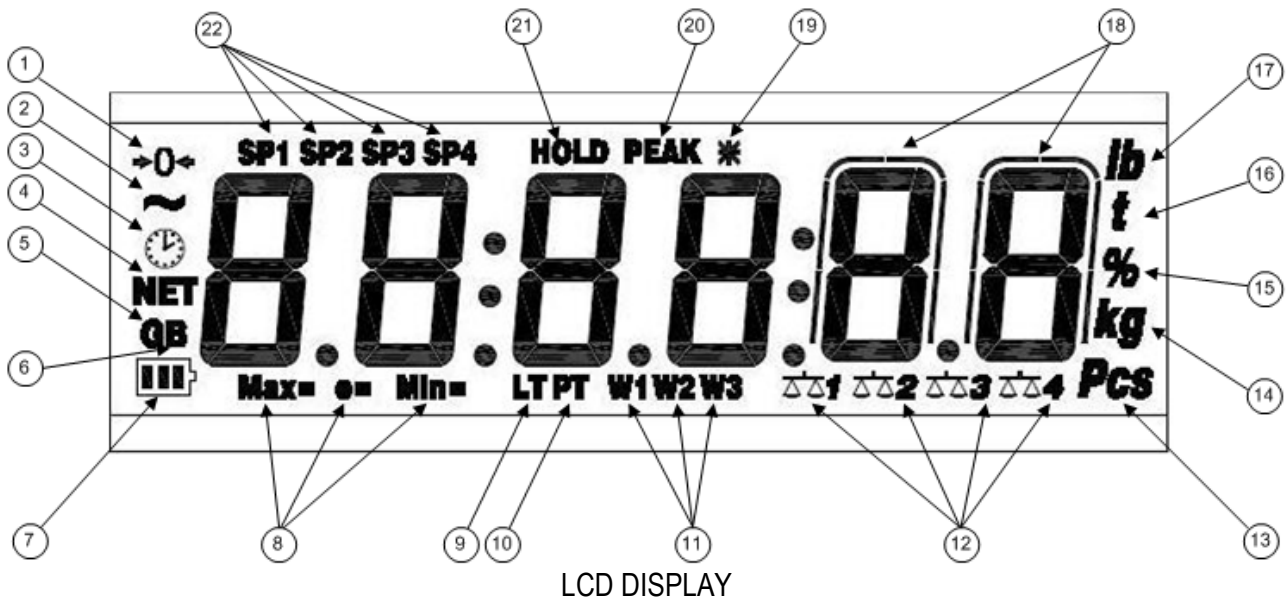

| NUMBER | SYMBOL             | FUNCTION  |
|--------|--------------------|---|
| (1)    | →0←                | The weight detected on the weighing system is near zero, within the interval of $-1/4 \div +1/4$ of the division.   |
| (2)    | ~                  | The weight is unstable.   |
| (3)    |                    | Steady: The time is being shown on the display, in the “HH:MM:SS” format.<br>Blinking: the date/time board is not present or the date/time is no set.   |
| (4)    | NET                | The displayed weight is a net weight.   |
| (5)    | G                  | The displayed value is a gross weight, if the Italian or English language is selected in the print configuration.   |
| (6)    | B                  | The displayed value is a gross weight, if the German, French or Spanish language is selected in the print configuration.  |
| (7)    |                    | Indicates the battery charge level: see section 9.5 - “LOW BATTERY WARNING”.  |
| (8)    | MAX=<br>MIN=<br>e= | When viewing the metric information, it identifies the indicated capacity range.<br>When viewing the metric information, it identifies the indicated minimum weigh range.<br>When viewing the metric information, it identifies the indicated division range. |
| (9)    | LT                 | The locked tare is enabled.   |
| (10)   | PT                 | The manual tare is active.  |
| (11)   | W1<br>W2<br>W3     | The instrument is in the first weighing range.<br>The instrument is in the second weighing range.<br>The instrument is in the third weighing range.   |
| (12)   |                    | Indicate the number of the slave being displayed, when in the SINGLE-MULTISCALE REPEATER functioning mode. In the other functioning modes scale nr. 1 is always shown.  |

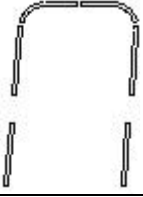
|      |   |  |
|------|---|--|
| (13) | <b>PCS</b>  | The number of pieces is being displayed.   |
| (14) | <b>kg</b>   | Indicates the unit of measure in use ("kg" for kilogram, "g" gram).                                |
| (15) | <b>%</b>  | Indicates the percentage of the weight on the scale ("Sample Weight Percentile" functioning mode). |
| (16) | <b>t</b>  | Indicates the unit of measure in use (tons).   |
| (17) | <b>LB</b>   | Indicates the unit of measure in use (pounds).   |
| (18) |  | These are displayed around the digits with higher sensitivity, when viewing the weight x 10.       |
| (19) | <b>*</b>  | Indicates that a key has been pressed.   |
| (20) | <b>PEAK</b>   | The PEAK function is enabled.  |
| (21) | <b>HOLD</b>   | The HOLD function is enabled.  |
| (22) | <b>SP1</b>  | The relay nr. 1 (optional) has been enabled.   |
|      | <b>SP2</b>  | The relay nr. 2 (optional) has been enabled.   |
|      | <b>SP3</b>  | The relay nr. 3 (optional) has been enabled.   |
|      | <b>SP4</b>  | The relay nr. 4 (optional) has been enabled.   |

## 9. BASIC FUNCTIONS

### 9.1 ZERO SCALE

By pressing the ZERO key, it is possible to zero a gross weight value which is within +/- 2% of the capacity; after the zeroing, the display shows 0 weight and the relative pilot lights are turned on.

### 9.2 TARE OPERATIONS

#### SEMI-AUTOMATIC TARE

By pressing the TARE key any weight value present on the display is tared: the display shows “**tArE**” for an instant and then 0 (net weight); the pilot lights turn on.

**NOTE:** The semiautomatic tare will be acquire only if the weight is AT LEAST A DIVISION, STABLE (instability ~ led off) and VALID (in other words, the OVERLOAD condition must not be created).

#### ENTERING THE MANUAL TARE FROM KEYBOARD

##### - With the 5-key indicator:

Press TARE for a few seconds: the display shows “- tM -” and then “000000”. Enter the desired value using the following keys:

**ZERO** decreases the blinking digit.

**TARE** increases the blinking digit.

**MODE** selects the digit to be modified (blinking); the scrolling of the digits takes place from left to right.

**C** if pressed for an instant it quickly zeros the present value; if pressed at length it allows to return to weighing without saving the changes made.

Confirm with the ENTER/PRINT key; the value will be subtracted from the weight present on the plate and the relative pilot lights will turn on.

##### - With the 17-key indicator:

1. digit the desired value through the numeric keys (depending on the model, press “i” or “.” to enter the decimal point).

**NOTE:** In the MASTER press the numeric 0 key and digit the desired value through the numeric keys.

2. confirm with TARE key

**NOTE:** If the entered value is not a multiple of the scale’s minimum division, it will be rounded off.

#### CANCELLING A TARE

One can manually cancel the tare value in different ways:

- unload the scale and press the TARE or ZERO key.

- carry out the tares in deduction, partially unloading the scale and pressing TARE to zero the display.

- press C without unloading the scale.

- enter a manual tare equal to 0.

**NOTE:** it is possible to automatically cancel the tare value; see the following section.

#### LOCKED/UNLOCKED/DISABLED TARE SELECTION

Normally, when a tare value is entered (automatic, manual, or from storage) by unloading the scale plate, the display shows the tare value with a negative sign (LOCKED TARE). For one’s convenience it is also possible to choose that the tare value cancels itself automatically each time that the scale is unloaded (UNLOCKED TARE); or disable the tare functions.

With the UNLOCKED tare:

**In case of SEMIAUTOMATIC TARE the net weight, before unloading the scale, may also be 0.**

**In case of MANUAL TARE or FROM DATABASE the net weight before unloading the scale must be greater than 2 divisions and stable.**

To set the type of tare:

- Turn on the indicator, press the TARE while the firmware version is displayed (the display shows the “typE” menu).

- Press ZERO many times (to scroll ahead through the parameters) or TARE (to scroll backwards) until one finds the “F.ModE” parameter.



- Press ENTER/PRINT to enter the menu.
- Press ZERO many times (to scroll ahead through the parameters) or TARE (to scroll backwards) until one finds the "tArE" parameter.
- Press ENTER/PRINT to enter the parameter.
- With the ZERO or TARE keys select the possible options: "LoCk" (locked tare), "unLoCk" (unlocked tare), "diSAb" (disabled tare).
- Confirm with ENTER/PRINT.
- Press the C key many times until the display shows the message "SAVE?".

Press ENTER/PRINT to confirm the changes made or another key for not saving.

**In the 17-key indicator**, it is possible to carry out the selection also during the weighing if the tare has not been disabled, by pressing in sequence the "F"+ "2" keys: the display shows "tA-L" = LOCKED TARE is selected; by pressing the same keys again the display shows "tA-U" = UNLOCKED TARE is selected.

The indicator stores the last selection made, also after it is turned off.

### 9.3 LIMITATION OF THE TARE FUNCTIONS

With approved instrument, it is possible to limit the tare functions, selecting: **SEtuP >> d.SALE >> yES (TECH.MAN.REF.)** the tare operations will have the following specifications:

| SCALE CAPACITY | FUNCTIONING   |
|----------------|---|
| < 100kg        | All the tare functions are disabled   |
| ≥ 100kg        | <ul style="list-style-type: none"> <li>- The SEMIAUTOMATIC TARE value can not be modified with a manual tare or from database.</li> <li>- The manual tare or from database can be entered or modified only with an UNLOADED scale.</li> <li>- It's possible to cancel the tare value only with an UNLOADED scale</li> </ul> |

With approved instrument, the **d.SALE** step is not displayed.

### 9.4 AUTO POWER OFF FUNCTION

It is possible to automatically turn off the indicator (from 1 to 255 minutes), or disable it; the auto power off takes place when, **with unloaded scale**, the weight has not been moved or a key has not been pressed for the time set: the display shows the "- oFF -" blinking message and an acoustic signal is emitted; after this the indicator turns off.

For the setting, follow the procedures below:



- Turn on the scale, press the TARE key while the firmware version is displayed (the display shows the "typE" menu).
- Press ZERO many times (to scroll ahead through the parameters) or TARE (to scroll backwards) until one finds the "F.Mode" parameter.
- Press ENTER/PRINT to enter the menu.
- Press ZERO many times (to scroll ahead through the parameters) or TARE (to scroll backwards) until one finds the "AutoFF" parameter.
- Press ENTER/PRINT to enter the parameter.
- With the ZERO or TARE keys select the possible options: "diSAb" (auto switch-off disabled), "EnAb" (auto switch-off enabled).
- Confirm with ENTER/PRINT; if "EnAb" has been selected, one will be asked to enter the number of minutes after which the indicator should turn off: enter a number between 1 and 255 (using the MODE key to select the digit to be modified and ZERO/TARE to decrease/increase it) and confirm with ENTER/PRINT.
- Press many times the C key until the display shows "SAVE?".
- Press ENTER/PRINT to confirm the changes made or another key for not saving.

## 9.5 LOW BATTERY WARNING

In TPWA - TPWP - TPWI version, the indicator is able to recognize whether it is powered from the mains or through a battery.

In TPWLK - TPWN09 version one should set the supply mode setting the step **SEtuP >> ALiM**.

If the indicator has the LCD display the charge level is shown in the weighing phase by the battery symbol:

-  : battery is charged.
  -  : battery is partially charged.
  -  : battery is discharged: connect the indicator to the mains for recharge the battery (if supplied) or replace it.
- Furthermore, for a few seconds the "Low.bat " message appears on the display (minimum level voltage).

When recharging the battery (if supplied), the indicator shows the recharging phase below:

**RECHARGING PHASE:**  →  →  →  →  ...

**RECHARGE IS COMPLETED:** 

### NOTES:

- While recharging, the instrument can be used as usual.
- The instrument automatically turns off when the voltage goes below the minimum level.
- It's possible to view the recharge percentile of the battery by pressing the **ZERO** key upon start-up (see section 5 – "POWER SUPPLY AND START-UP").

## 9.6 "TILT" DEVICE

The TILT is a device which inhibits the indicator's weighing system and starts working when the instrument's inclination is greater than 2% for the pallet truck application or 5% for application on lift trucks.

The "tilt" message is shown on the display, alternate to the weight value.

The activation of the tilt alarm has a delay of about three seconds from the detection of the exceeding inclination.

See the electrical connection scheme (**TECH.MAN.REF.**) for the connection of the device.

## 9.7 MULTI RANGE FUNCTIONING (for legal for trade approved instruments)

The multi range functioning allows to subdivide the scale capacity in two or three ranges, each which is up to 3000 divisions, improving in this way the first range division in the dual range and the first two ranges in the triple range.

For example, with a 10 kg cell platform it is possible to approve the weighing system with:

- A single range: 6 kg capacity and 2 g division (3000 div.).
- Dual range: 6 / 3 kg capacity and 2/1 g division (3000 + 3000 div.).
- Triple range: 15 / 6 / 3 kg capacity and 5/2/1 g division (3000 + 3000 + 3000 div.).

### NOTES:

- For the approval of the weighing system in dual and triple range the cell must have better technical features in comparison to the cell used for the approval in a single range.

The multirange functioning is shown by the turning on of the relative LED which identifies the range in which one is operating; by passing to the second range, the second range division is enabled; by passing to the third range, the third range division is enabled. At this point the first range division is restored **only by passing by the gross zero of the scale.**

- The selection of the range number with multirange functioning is made during the indicator's calibration (**TECH.MAN.REF.**).

## 9.8 REMOTE CONTROL (OPTIONAL)

**NOTE: indoor use only.**

If the model is provided for the remote control, it is possible to remotely use the functionality of the ZERO, TARE, MODE, ENTER/PRINT keys or just the TARE key. To choose which type of functioning follow the below procedure:

- Turn on the scale; press the TARE key while the firmware version is displayed (the display shows the “typE” menu).
- Press ZERO many times (to scroll ahead through the parameters) or TARE (to scroll backwards) until one finds the “F.ModE” parameter.
- Press ENTER/PRINT to enter the menu.
- Press ZERO many times (to scroll forwards through the parameters) or TARE (to scroll backwards) until one finds the “ir.ConF” parameter.
- Press ENTER/PRINT to enter the parameter.
- With the ZERO or TARE keys select the possible options: “ir no” (disabled remote control), “ir 1” (all the remote control keys function as the TARE key) or “ir 4” (the remote control keys functions as ZERO, TARE, MODE and ENTER/PRINT).
- Confirm with ENTER/PRINT.
- Press the C key many times until the message “SAVE?” appears on the display.
- Press ENTER/PRINT to confirm the changes made or another key to not save.

In the “multifunction” configuration, the remote control keys repeat the keys’ functions (both the ones obtained with a SHORT pressing as well as those with a LONG pressing) and they correspond to the following indicator keys:

| REMOTE CONTROL KEY | INDICATOR KEY |
|--------------------|---------------|
| ZERO               | ZERO          |
| TARE               | TARE          |
| F1/MODE            | MODE          |
| F2/PRINT           | ENTER/PRINT   |

### 9.8.1 STAND-BY FUNCTION

In the “multifunction” configuration, by pressing at length the ZERO key, it’s possible to put the instrument in stand-by; by pressing any other key one returns to the weighing mode.

## 9.9 DATE/TIME ADJUSTMENT (OPTIONAL)

The indicator can be fitted with the date/time board (optional or included, depending on the model); in this case, the “CLoCk” message is shown when instrument is turned on.

To set the date/time follow the procedure below:

- Turn on the scale, press the TARE key while the firmware version is displayed (the display shows the “typE” menu).
- Press ZERO many times (to scroll ahead through the parameters) or TARE (to scroll backwards) until one finds the “F.ModE” parameter.
- Press ENTER/PRINT to enter the menu.
- Press ZERO many times (to scroll forwards through the parameters) or TARE (to scroll backwards) to find the “CLoCk” parameter.
- Confirm with ENTER/PRINT: in this order one will be asked to enter the day, month, year, hour, and minutes. The entry of each parameter must be confirmed with ENTER/PRINT.
- Press the C key many times until the message “SAVE?” appears on the display.
- Press ENTER/PRINT to confirm the changes made or another key to not save.

### NOTES

- With the 17-key indicator, it is possible to programme the date and time during the weighing, pressing in sequence the F and 8 keys.
- If the supply cable is disconnected or the battery has been replaced, the indicators supplied with a date/time board can keep the date/time for 5 minutes
- **The “CLoCk” parameter is displayed if there is the date/time option.**

## 9.10 “SCREEN SAVER” FUNCTION (OPTIONAL OR INCLUDED DEPENDING ON THE MODEL)

If the indicator is fitted with the date/time function (optional or included depending on the model), it is possible to enable the “Screen Saver”: after a programmable time (from 1 to 255 minutes) with the scale unloaded, the time is shown on the display, in the “HH:MM:SS” format and the clock symbol (  ) is enabled. As soon as a weight variation is detected, or a key is pressed, the indicator returns to viewing the current weight.

To set the function:

- Turn on the scale, press the TARE key while the firmware version is displayed (the display shows the “typE” menu).
- Press ZERO many times (to scroll ahead through the parameters) or TARE (to scroll backwards) until one finds the “F.ModE” parameter.
- Press ENTER/PRINT to enter the menu.
- Press ZERO many times (to scroll forwards through the parameters) or TARE (to scroll backwards) to find the “SCr.SAV” parameter.
- Press ENTER/PRINT to enter the parameter.
- With the ZERO or TARE key select the possible options: “no” (disabled), “yES” (enabled).
- Confirm with ENTER/PRINT; if one has selected “yES”, one is asked to enter the number of minutes after which the indicator should show the time: enter a number between 1 and 255 (using the MODE key to select the digit to be modified and the ZERO/TARE keys to decrease/increase it) and confirm with ENTER/PRINT.
- Press the C key many times until the display shows the message “SAVE?”.
- Press ENTER/PRINT to confirm the changes made or another key to not save.

**NOTE: the “SCr.SAV” parameter is shown if there is the date/time option.**

## 9.11 PRINTING

If a printer is connected, it is possible to print the programmed weight data, for example:

- 4 heading lines of 24 characters
- GROSS weight
- TARE weight
- NET weight
- ticket number
- date and time (optional or included depending on the model)
- a CODE 39 bar code (both with the LP542PLUS labeller as well as the TPR thermal printer).

Besides the generic printing described above, each single functioning mode will have some specific printouts, which are described in the operating mode.

### Executing printouts with NON approved scales.

In order to print with non approved scales the following conditions must exist:

- the weight must be stable;
- the gross weight must be  $\geq 0$ ;
- the printout is always active;

**NOTE:** In the totaliser mode in order to print the totalised weight the following must take place:

- the weight must be stable;
- the net weight must be  $\geq$  of a division with normal or fast totalisation;
- the net weight must be  $\geq$  of 10 divisions with automatic totalisation;
- the printing is reactivated depending on how the “rEACT” parameter has been set in the set-up environment: passage by zero of the NET weight, weight instability, or always (see section 9.12 - “REENABLING THE PRINTOUTS AND THE INDICATOR FUNCTIONS”).

### Legal for Trade scale printing.

In order to be able to print with a legal for trade scale the following conditions must exist:

- the weight must be stable;
- the net weight must be  $\geq$  the minimum weight (minimum of 20 divisions).
- the printing is reactivated depending on how the “rEACT” parameter has been set in the set-up environment: passage by zero of the NET weight, weight instability, or always (see section 9.12 - “REENABLING THE PRINTOUTS AND THE INDICATOR FUNCTIONS”).

**Notes:**

- The printing is confirmed by the indication on the display of the "Print" message or "-tot-" in case of totalisation.
- If the printout is not reenabled the display shows the "no.0.unS" message
- With the weight unstable the display shows the "unStAb" message.
- If the gross or net weight is less than the requested minimum weight, by pressing the ENTER/PRINT key, the display shows the "LoW" error message.
- If the indicator is in under load or over load status, by pressing the ENTER/PRINT key, the display shows the "un.oVer" error message.

To configure the printouts, go to the section 9 - "PROGRAMMING THE PRINTOUTS" in the technical manual (TECH.MAN.REF.).

**9.12 REENABLING THE PRINTOUTS AND THE INDICATOR FUNCTIONS**

While using the indicator, it is possible to incur into the "no.0.unS" error shown on the display along with an acoustic signal; this means that the printing or the function which one wants to carry out must be reenabled (in order to avoid unwanted executions).

It is possible to set the reenabling in different ways: "passage by zero of the net weight", "weight instability" or "always". Follow the procedure below:

- Turn on the scale, press the TARE key while the firmware version is displayed (the display shows the "typE" menu).
- Press ZERO many times (to scroll ahead through the parameters) or TARE (to scroll backwards) until one finds the "F.ModE" parameter.
- Press ENTER/PRINT to enter the menu.
- Press ZERO many times (to scroll forwards through the parameters) or TARE (to scroll backwards) until one finds the "rEACt" parameter.
- Press ENTER/PRINT to enter the parameter.
- With the ZERO or TARE keys select the possible options: "ZEro" (passage by zero of the net weight), "inSt" (instability), "ALWAYs".
- Confirm with ENTER/PRINT.
- Press the C key many times until the message "SAVE?" is shown on the display.
- Press ENTER/PRINT to confirm the changes made or another key to not save.

**9.13 DISPLAY OF METRIC DATA (inFo)**

The indicator is fitted with a function named "INFO", thanks to which it is possible to view the configuration metric data:

- **With the 5-key indicator** : keep the **C** key pressed until the display shows "inFo", and release.
- **With the 17-key indicator** : depending on the model:
  - press the key **i** once, or:
  - press the keys **MODE + C** in sequence, or:
  - keep the **C** key pressed until the display shows "inFo", and release.
- The capacity value of the first range will appear.
- Press the ZERO key to scroll the following data, in this order:  
Capacity 1° range ⇒ Minimum weigh 1° range ⇒ Division 1° range ⇒  
Capacity 2° range ⇒ Minimum weigh 2° range ⇒ Division 2° range ⇒  
Capacity 3° range ⇒ Minimum weigh 3° range ⇒ Division 3° range ⇒  
Capacity 1° range ⇒.....
- Press the TARE key to scroll backwards the metric data.
- Press the C key to return to weighing.

**NOTES:**

- The minimum weigh corresponds to 20 net weight divisions.
- The data of the second and third range appear only if actually configured.

## 10. ADDITIONAL FUNCTIONS OF THE 17-KEY INDICATOR

### 10.1 STORED TARE MEMORY VALUES

It's possible to store up to **30 tare memory values**, identified by the location numbers 1 to 30, which the user can recall when needed.

To insert or modify a tare value:

- press the keys "F" + "9" in sequence - the display will indicate "t nn". in which nn is the storage number to be entered. For example, by pressing "01" and then ENTER/PRINT, the display will indicate "t00000" or any value that already exists in the tare memory location "01."
- Insert the tare value with the numeric keyboard (with the C key one quickly zeros the entered value) and press ENTER/PRINT.
- Repeat the sequence for the following memory positions.

**The value must be entered as a multiple of the scale's minimum division.**

### RECALLING STORED TARE VALUES

To recall a stored value:

- Press the keys "F" + "1" in sequence. The display will indicate "t nn" in which nn is the storage number to be entered. Press the keys corresponding to the desired tare value location in memory (01-30) and then ENTER/PRINT, the tare will be enabled.

### RECALLING STORED TARE VALUES

To recall a stored value:

- Press the keys "F" + "1" in sequence. The display will indicate "t nn" in which nn is the storage number to be entered.
- Press the keys corresponding to the desired tare value location in memory (01-30) and then ENTER/PRINT, the tare will be enabled.

### 10.2 ENTERING THE IDENTIFICATION CODE

It is possible to insert 2 numerical codes of up to 10 digits in length (maximum) to use as a reference during printing:

- Press the "F" + "3" keys in sequence. The display will indicate "Id n" in which n identifies the code number which one wants to enter.
- Press 1 or 2: the display will show 00000 or the last entered value.
- Enter the code through the numeric keyboard and confirm with ENTER/PRINT or press C to exit without saving the modifications. While entering, just the last 6 digits entered will be displayed; in any case it is possible to scroll all the digits using the MODE key.

After its entry, the code will automatically be printed with its abbreviation (ID1 or ID2) in each printing that will be made. It is also possible to set the automatic cancellation of the code after the printing made.

**IN ANY CASE**, the stored codes are cancelled when the instrument is turned off.

#### NOTES:

- The values between 0'000'000'001 and 9'999'999'999 are valid; by entering 0'000'000'000 the code is cancelled.
- In the TOTALIZER functioning mode, the codes will be printed only in the printing of the total.

### LOCKED / UNLOCKED CODE SELECTION

Normally the code is LOCKED, in other words once it is set it remains stored (and therefore printed) until it is cancelled or until the instrument is turned off. In any case it is possible to make it so the code is cancelled as soon as it is printed (UNLOCKED CODE).

- Press the keys "F" + "4" in sequence; the display indicates "MId n".
- Press "1"; the display indicates "Id1 U" = CODE 1 UNLOCKED.
- Press the same keys again: the display indicates "Id1 L" = CODE 1 LOCKED.
- Repeat the same operations for CODE 2.

### 10.3 KEYBOARD LOCK

It is possible to disable the keyboard functions in order to avoid accidental pressing of the keys:

- Press in sequence the **F** and **0** keys: the display shows "LoC.kEy" for an instant (LOCKED KEYBOARD).
- If in this status a key is pressed the message "LoCkEd" is shown on the display.
- To UNLOCK the keyboard, press again the **F** and **0** keys: the display shows "unL.kEy" for an instant (UNLOCKED KEYBOARD).

**NOTE:** The keyboard may be disabled also by closing an input, if programmed, of the optional expansion board (also in the 5-key indicator): refer to the "inPutS" parameter of the set-up environment (**TECH.MAN.REF.**); in this case however when the keys are enabled or disabled, the message "LoCkEd" does not appear on the display and upon pressing a key the display shows "LoCkin" for an instant.

### 10.4 REPETITION OF THE LAST PRINTOUT MADE

Press in sequence the **F** and **PRINT** keys: the last printout made by the indicator will be repeated.

**NOTE:** By turning off the instrument, the information relative to the last printout made, will be lost; therefore this function is not enabled until the first printout is made.

## 11. SELECTABLE OPERATING MODES

In addition to the STANDARD weighing mode - with TARE deduction and transmission of data, the indicator can carry out one of the following functions: UNIT OF MEASURE/POUNDS CONVERSION, NET/GROSS SWITCH, SET POINT ON THE GROSS WEIGHT, SET POINT ON THE NET WEIGHT, IN/OUT, SINGLE - MULTISCALE REPEATER, ALIBI MEMORY, +/- TOLERANCE CHECK, SAMPLE WEIGHT PERCENTAGE, SINGLE SCALE REPEATER, DISPLAY WITH SENSITIVITY X 10, FREEZING OF THE WEIGHT ON THE DISPLAY, PEAK DETECTOR, HORIZONTAL TOTALIZER, VERTICAL TOTALIZER, PIECE COUNTING.

Each functioning mode foresees the turning on of various function pilot lights, described in detail in the sections "KEYS AND INDICATORS OF THE FRONT PANEL" and "SYMBOLS ON THE LCD DISPLAY".

**To set the operating mode, carry out the following procedures:**

- Turn on the scale, press the TARE key while the firmware version is displayed (the display shows the "typE" menu).
- Press ZERO many times (to scroll ahead through the parameters) or TARE (to scroll backwards) until one finds the "F.ModE" parameter.
- Press ENTER/PRINT to enter the menu (the display shows the "FunCt" menu).
- Press ENTER/PRINT to enter the parameter.
- With the ZERO or TARE keys select the possible options:
 

|              |                                      |
|--------------|--------------------------------------|
| <b>Std</b>   | Unit of measure / pounds conversion  |
| <b>ntGS</b>  | Net weight / gross weight conversion |
| <b>StPG</b>  | Set point on the GROSS weight        |
| <b>StPn</b>  | Set point on the NET weight          |
| <b>inout</b> | Input / output weighing              |
| <b>MAStr</b> | Single – multiscale repeater         |
| <b>ALibi</b> | Alibi memory                         |
| <b>ChECk</b> | +/- Tolerance Check                  |
| <b>PErC</b>  | Sample weight percentage             |
| <b>rEPE</b>  | Single scale repeater                |
| <b>ViSS</b>  | Sensitivity times ten                |
| <b>hLd</b>   | Hold                                 |
| <b>PEAk</b>  | Peak detector                        |
| <b>tot o</b> | Horizontal totalizer                 |
| <b>tot S</b> | Vertical totalizer                   |
| <b>Coun</b>  | Counting                             |
- Confirm with ENTER/PRINT; if one has selected the inout, MASTr, ChECk, PErC, tot o, tot S or Coun mode, one will be asked to select one or more operating parameter; refer to the specific functioning mode section for the relative description.

- The instrument automatically goes to the following step.
- Press many times the C key until the display shows the message "SAVE?".
- Press ENTER/PRINT to confirm the changes made or another key to not save.

**NOTE:** If there is a printer, once the functioning mode is selected, the relative printout is automatically enabled, depending on the type of printer selected in the **SEtuP >> SEriAL >> CoM.Prn >> Pr.ModE (TECH.MAN.REF.)**.

### 11.1 UNIT OF MEASURE/POUNDS CONVERSION (Std)

By pressing the MODE key the weight conversion between the scale unit of measure and lb is made and vice versa.

**NOTES:**

- The conversion takes place for any unit of measure set during the calibration.
- With APPROVED instrument the weight in pounds is displayed for 5 seconds, after which the display goes to the scale unit of measure. During the viewing in pounds it is not possible to print the weight (when pressing ENTER/PRINT the message "ConV" is shown and an acoustic signal is emitted).

### 11.2 NET/GROSS SWITCH (ntGS)

If a tare is set by pressing the MODE key, for about 3 second interval, the gross weight is displayed.

**NOTE:** While the gross weight is being viewed it is not possible to print.

### 11.3 SET POINT ON THE GROSS WEIGHT (StPG)

By selecting this functioning mode, in the normal scale status, one enables the function of the relays on the GROSS weight; with the optional boards, it is possible to use up to 4 relays.

In the **outPut** menu of the SET-UP environment (**TECH.MAN.REF.**), one sets the functioning mode for each relay used: none, with hysteresis (enabling and disabling set point) without hysteresis (single set point).

Furthermore it is possible to set the status of the relays (normally open or normally closed), or the type of check (direct or weight stability).

**MODE WITH HYSTERESIS**

One enters two SET POINTS for each relay: a DISABLING one, which, when the gross weight is lower than it, it disables the concerned relay; and an ENABLING one, which, when the gross weight is equal or greater than it, it enables the concerned relay.

By keeping the ENTER/PRINT key pressed for about 3 seconds one enters the DISABLING and ENABLING SET POINT values, only for the configured relays:

- The display shows " S1 oF " (DISABLING relay 1 SET POINT): press ENTER/PRINT to enter the Step.
- Use the MODE key to choose the digit to be increased (BLINKING DIGIT), the scrolling of the digits goes from left to right.
- Decrease or increase the value using the ZERO or TARE keys.
- When finished entering the values, confirm with ENTER/PRINT.
- The display shows " S1 on " (ENABLING relay 1 SET POINT): enter the weight value like in the preceding SET POINT and confirm with ENTER/PRINT.
- With the C key, one quickly zeros the set point value.
- In the same way go ahead with the "Sb2.oF", "Sb2.on", "Sb3.oF", "Sb3.on", "Sb4.oF", "Sb4.on" (if present).
- Once finished the programming of the set points, one should exit with the C key to return to weighing.

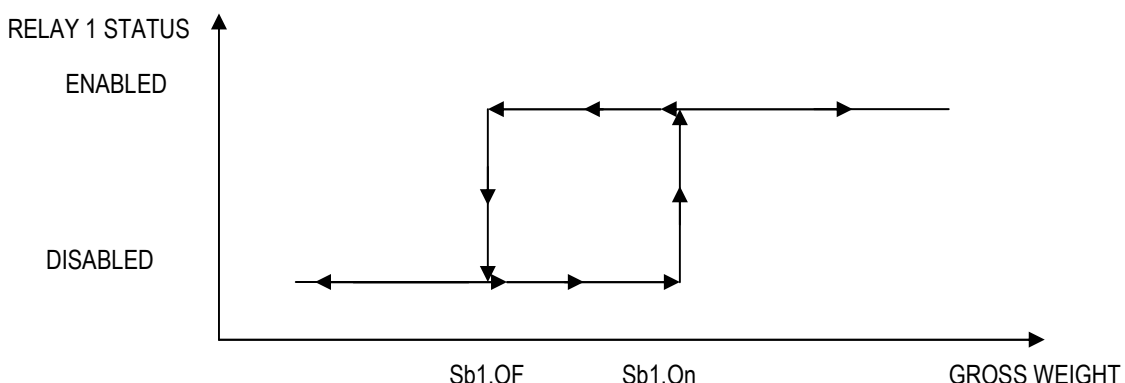



**NOTES**

- If the relay functioning mode has not been configured, the prolonged pressure of the ENTER/PRINT key **has no effect**.
- The DISABLING SET POINT must be equal or less than the ENABLING one;  
if in the DISABLING SET POINT one enters and confirms a value greater than the ENABLING one, the instrument will automatically set the same value in the ENABLING step and the anomaly is indicated through the "ModiFY" message at the exit of the configuration MENU of the SET POINTS.
- If in the ENABLING SET POINT one enters a value lower than the DISABLING one, the instrument does not allow to confirm.
- if one enters a set point with a number of divisions not coherent with the set minimum division it will be rounded up to the multiple of the minimum division closest to it.
- The 0 value is valid for the enabling and the disabling set points and just the set points greater or equal to zero are accepted.
- The check of the weight remains active on the present value even during the modification of the SET POINT, until the new value is confirmed.
- At start-up, the relays are managed from when the weight is displayed and these take on the configuration set in the set-up environment. These are not managed inside the technical set-up.
- The tare operations are active.

**MODE WITHOUT HYSTERESIS**

It is the same as the functioning mode with hysteresis, except that one enters just one SET POINT value (therefore the enabling threshold coincides with the disabling threshold).

**11.4 SET POINT ON THE NET WEIGHT (StPn)**

By selecting this functioning mode, in the normal scale status, one enables the function of the relays on the NET weight; the entry of the SET POINTS and the functioning notes are the same as the gross weight mode.

**11.5 INPUT/OUTPUT (inout)**

Simple display functioning mode with in / out weighing function: the indicator acquires two weight values through the confirmation of the operator and calculates the difference, automatically printing the data (if the presence of a printer has been configured).

Once the in/out mode has been selected, the message "tyPE" is shown and one is asked to select with ENTER/PRINT the printing mode of the acquired data:

- **G.t. gross/tare:**
  - GROSS Greater weight with unit of measure
  - TARE Lesser weight with unit of measure.
  - NET Difference between GROSS and TARE with unit of measure
- **1<sup>st</sup>.2<sup>nd</sup> first weigh/second weigh:**
  - WEIGH 2 Second weight with unit of measure.
  - NET Difference without sign between WEIGH 1 and WEIGH 2 with unit of measure.
- **in.out input/output:**
  - INPUT First weight with unit of measure.
  - OUTPUT Second weight with unit of measure.
  - NET Zero weight with unit of measure >> if WEIGH 1 = WEIGH 2
  - INPUT NET >> if WEIGH 1 > WEIGH 2  
Difference without sign between INPUT and OUTPUT with unit of measure.
  - OUTPUT NET >> if WEIGH 1 < WEIGH 2  
Difference without sign between INPUT and OUTPUT with unit of measure.

**PROCEDURE:**

- With the MODE key of the 5-key indicator (or keys “F”+ “1”of the 17-key indicator), one acquires the first weight, on the display is shown “ - - 1 - - -” accompanied by a prolonged beep;
- By pressing again MODE key of the 5-key indicator (or keys “F”+ “2”of the 17-key indicator), one acquires the second weight, and on the display is shown “ - - 2 - - -” accompanied by a prolonged beep.
- **NOTE:** The acquisition of the second weight is made only if the setting of the rEACt parameter in the set-up environment has been respected (passage by zero of the weight, instability, or always); see section 9.12 - “REENABLING THE PRINTOUTS AND THE INDICATOR FUNCTIONS”.
- When the second weight is acquired, the data printout is commanded.

It is possible to interrupt the weighing cycle by pressing the ENTER/PRINT key (in the 5-key indicator) or C (in the 17-key indicator) after the acquisition of the first weight: On the display the message “CLEAR?” is shown accompanied by a prolonged beep. Press ENTER/PRINT to confirm the cancelling of the first acquired weight or another key to not confirm.

**NOTES:**

- The weight is acquired if:
  - With a NON APPROVED scale one has a STABLE weight and GREATER than 0.
  - With an APPROVED scale one has a STABLE weight and GREATER than 20 divisions.
  - If the setting of the rEACt parameter in the set-up environment has been respected (passage by zero of the weight, instability, or always); see section 9.12 - “REENABLING THE PRINTOUTS AND THE INDICATOR FUNCTIONS”.
- The tare operations are DISABLED.

**11.6 SINGLE - MULTISCALE REPEATER (MAStR)**

The system is made up of one or more indicators (up to 4, called **SLAVES**), connected to one or more weighing system, which communicate with another indicator (called **MASTER**) which acts as weight repeater, on which it is possible to view (or printed if the printer is provided) the weight of each single scale or the sum of the weight detected by the single scales.

In the MASTER, by selecting with ENTER/PRINT in this operating mode:

- one is asked to enter the number of the SLAVES which one wants to use: for an instant “nuMSL” is displayed; then, one enters the number (between 01 and 04).
- one is asked to enter the protocol type.
- one is asked to enter the SLAVE keyboard type: “kb.dFW” (for DFW type instruments), “kb.dFkr” (for DFWKR type instruments), “kb.dGt” (for DGT type instruments), “kb.CPWE” (for CPWE type instruments), “kb.3590” (for 3590 type instruments).

In the SLAVES, instead, one needs to set a different functioning mode than the “MAStR” and enter a code (between 01 and 04, to identify each single SLAVE) in **SEtuP >> SEriAL >> CoMPC >> PCModE >> 485 (see set-up environment, TECH.MAN.REF.)**.

**NOTES:**

In this functioning mode, the printer port may have only the transmission modes to the printer and the “rEPE6” transmission mode, see section 7.4 – “SERIAL PORT TRANSMISSION MODES”, **TECH.MAN.REF..**

**FUNCTIONING**

When turned on, the MASTER predisposes itself for the connection to the SLAVES present (“ECo n” message appears, in which n is the SLAVE number which is to be detected): if it has detected more than one SLAVE, it shows the “SuM” message and then the sum of the weights of all the detected SLAVES; if only one SLAVE is detected, it positions itself on that scale.

- **If the MASTER indicator has a 5-key keyboard**, by pressing the MODE key various times:
  - if just one slave is configured this is repeated also on the active slave in that moment;
  - if various slaves are configured one goes from SLAVE to SLAVE, ordered by 485 addresses: the display shows “SCA n” (in which n is the SLAVE number); after this, the weight transmitted by the selected SLAVE is displayed. In this mode, about every 10 seconds, the message “SCA n” appears, indicating the meaning of the shown data and in which n is the number of the active scale in that moment.

By pressing the ZERO, TARE and ENTER/PRINT keys on the MASTER, these are repeated also on the active SLAVE in that moment.

It is possible to view the sum of weights present on all the detected scales, (also if lower than the number set in the **F.ModE >> FunCt >> MASTr >> nuMSL** step, as long as greather than 1), by pressing the MODE key pressed for a few seconds: the display shows “SuM” and then the sum of the net weight present on the detected scales.

**In the display of the sum:**

- the “SuM” message appears about every 10 seconds and it indicates that the sum of the weights present on the scales is being displayed.
- The reference unit of measure is that of the connected SLAVE with the lowest address; if the other weights have different units of measure, these are automatically converted.
- If the sum of the weights is greater than 999999, the segments in the upper part of the display are turned on.
- If the sum of the weights is less than -99999, the segments in the lower part of the display are turned on.
- If the sum of weights is not valid (because one or more slaves is in underload or overload), the segments in the central part of the display are turned on.

- **If the MASTER indicator has a 17-key keyboard**, the functioning is the same as the preceding one. Furthermore by pressing the numeric keys:
  - if just one slave is configured this is repeated also on the active slave in that moment;
  - if various slaves are configured, it is possible to directly select the number of the desired SLAVE through the relative numeric key of the keyboard (**I.E.:** MASTER → press the 1 key → selection of SLAVE 1).

**NOTE:** the functionality of the MODE key is the same as the preceding way.

**EXECUTION OF THE PRINTOUTS**

If there is a printer on the master:

- the printer has to be selected both in the SLAVE and in the MASTER (**SEtuP >> SEriAL >> CoM.Prn >> Pr.ModE** parameter, **TECH.MAN.REF.**)
- it's possible to direct on it the printouts and the heading configured in the active slave, by pressing on the MASTER or on the SLAVE the dedicated key (depending on the selected function on the SLAVE). In order to configure this format refer to section 9 - “PROGRAMMING THE PRINTOUTS”, **TECH.MAN.REF.**
- by pressing the ENTER/PRINT key when the sum is displayed, it is possible to execute a printout with the weights of all the detected scales and their sum. In order to configure this format refer to section 9 - “PROGRAMMING THE PRINTOUTS”, **TECH.MAN.REF.**; the heading is the one programmed in the MASTER

If there is a printer on a slave:

- the printer has to be selected in the SLAVE (**SEtuP >> SEriAL >> CoM.Prn >> Pr.ModE** parameter, **TECH.MAN.REF.**) but not in the MASTER.
- it is possible to execute the printout configured in the SLAVE

**Examples of printout:**

2 slaves connected to the master (TPR printer)

Slave 1

Slave 2

Master

|         |        |          |
|---------|--------|----------|
| SCALES  | 1      |          |
| SLAVE 1 | LINE 1 |          |
| SLAVE 1 | LINE 2 |          |
| SLAVE 1 | LINE 3 |          |
| SLAVE 1 | LINE 4 |          |
| GROSS   |        | 1.091 kg |
| TARE    |        | 0.091 kg |
| NET     |        | 1.000 kg |

|         |        |          |
|---------|--------|----------|
| SCALES  | 2      |          |
| SLAVE 2 | LINE 1 |          |
| SLAVE 2 | LINE 2 |          |
| SLAVE 2 | LINE 3 |          |
| SLAVE 2 | LINE 4 |          |
| GROSS   |        | 1.565 kg |
| TARE    |        | 0.152 kg |
| NET     |        | 1.413 kg |

|        |        |          |
|--------|--------|----------|
| MASTER | LINE 1 |          |
| MASTER | LINE 2 |          |
| MASTER | LINE 3 |          |
| MASTER | LINE 4 |          |
| SCALES | 1      | 1.000 kg |
| SCALES | 2      | 1.413 kg |
| SUM    |        | 2.413 kg |

**NOTES:**

If the printer has been selected in the MASTER but not in the SLAVE, it is not possible to print.

If more than one SLAVE is present, the number of the SLAVE from which the weight comes from will be added on each printout on the MASTER.

On the MASTER it is also possible to display and print the sum of the weights of a number of SLAVES lower than the value programmed in the **FunCt >> MASTr >> nuMSL** step, by turning off the SLAVES that are not used.

**WARNING:**

- To carry out the weight repeater function it is sufficient that just one SLAVE instrument in the system be turned on. When turned on, the MASTER places itself automatically on the first turned on SLAVE (lowest 485 address); if all the instruments are off or if the radio signal does not reach the MASTER, on the same display the "ECo n" message is displayed in which n is the address number of the SLAVE with which one is trying to communicate.
- If there are various slaves, in no case is it possible to transmit the functionality of the **MODE** key and the numeric keys (in case of 17-key indicator) to the active slave.
- To carry out the sum function, it is necessary to have a connection with at least two SLAVES.
- In the sum mode, it isn't possible to transmit the functionality of the **ZERO**, **TARE**, **ENTER/ PRINT** and **C** keys to the SLAVES.
- If the connection is lost with the SLAVE which is acting as a repeater, the MASTER will try to reconnect it; if after about a second this does not happen, it connects with the following SLAVE.
- If the connection is lost with a SLAVE in the sum mode, the MASTER tries to reconnect it: if this happens, it remains in the sum mode, otherwise it passes to the repeater mode of the following SLAVE.

**TURN OFF THE MASTER AND THE SLAVES**

If the MASTER displays the sum of the weights:

- by pressing at length the **C** key on the MASTER it is possible to turn off only this indicator.
- by pressing at length the **C** key on a SLAVE it is possible to turn off only that indicator: after a few instants the MASTER displays the "ECo n" message in which n is the number of the SLAVE that has been turned off and then the weight transmitted by the next detected SLAVE.

If the MASTER displays the weight transmitted by a SLAVE:

- by pressing briefly the **C** key on the MASTER this is repeated on the active SLAVE.
- by pressing the **C** key on the MASTER until the "-OFF-" message is displayed, it is possible to turn off the active SLAVE; the "-OFF-" message is displayed on the MASTER for a few seconds, then it displays the "ECo n" message in which n is the number of the SLAVE that has been turned off and then the weight transmitted by the possible next detected SLAVE. Note: while the "-OFF-" message is displayed it is possible to turn off the MASTER by pressing again at length the **C** key.
- by pressing the **C** key on the MASTER until the "-OFF-" message is displayed for the second time it is possible to turn off only the MASTER indicator.
- by pressing at length the **C** key on the active SLAVE it is possible to turn off only that indicator: the MASTER displays the "-OFF-" message and then the "ECo n" message in which n is the number of the SLAVE that has been turned off; then the MASTER displays the weight transmitted by the possible next detected SLAVE.
- by pressing at length the **C** key on a SLAVE that is not active it is possible to turn off only that indicator.

It is also possible to turn off only the MASTER indicator while it displays the "ECo n" message, by pressing at length the **C** key.

**11.7 ALIBI MEMORY (ALibi) (OPTIONAL)**

The alibi memory allows to file the transmitted weight values in the computer for data processing and/or integration. The filed values may then be recalled from the PC serial line or directly on the indicator's display for a following check.

The storage of a weigh takes place either following the reception of the serial command or following the pressure of the ENTER/PRINT key: the indicator transmits on the PC serial line the gross and tare weights and an ID which clearly identifies the weigh.

**The ID has the following format:**

<Rewriting number> — <Weigh number>

- Rewriting number: number of 5 digits which may go from 00000 to 00255; it indicates the number of complete rewritings of the alibi memory.
- Weigh number: number of 6 digits which may go from 00000 to 131072; it indicates the weigh number in the current rewriting of the alibi memory

With each storage the weigh number is increased of 000001; when this reaches the 131072 value, it restarts from 000000 and the rewriting number increases of 00001.

Therefore the weigh relative to an ID may be verified just if:

- it has a rewriting number equal to the current one of the alibi memory and a weighing number equal or less than the last value received with the "PID" command;
- it has a rewriting number equal or greater than zero, but less than 1, in comparison to the current value of the alibi memory, and a weigh number greater than the last value received with the "PID" command.

Example:

If the stored weigh is the following:

"PIDST,1, 1.000kg, 1.000kg,00126-131072"

and the following will be:

"PIDST,1, 1.000kg, 1.000kg,00127-000000"

The storage of a weigh is possible only if the weight is stable and valid (in other words not in under load nor in overload), if the gross weight is equal or greater than zero and without the TILT alarm (see paragraph 9.6).

The storage of the weigh by pressing a key is possible only if:

- the function is active (net weight passed from 0 or weight instability, or always depending on how the **F.ModE>> rEACT** step has been configured in the technical set-up, **TECH.MAN.REF.**).
- the net weight is at least of 20 divisions with approved instrument.

If these conditions are not respected:

- in the response to the PID serial command one has "NO" in the place of the ID.
- there is no transmission if ENTER/PRINT has been pressed.

When the weight is transmitted with the ID following the pressing of the ENTER/PRINT key, the display shows for about 2 seconds the message " tr.id ", and the transmitted string is the following:

**<ESC>[II]PIDSS,B,LLLLLLLLLUU,YYTTTTTTTTTUU,(ID | NO)<STX>**.

See the following section "Serial commands" for the string description.

**NOTES:**

- With approved or not approved instrument, the storage of the weigh through the PID serial command is always possible for all the weighs from 0 to full range value.

**READING OF THE WEIGHS CARRIED OUT**

In order to read the information relative to the weighs carried out:

- Press the **MODE** key.
- The message "rew.id" appears; now one should enter the rewriting number (from 00000 to 00255) and press ENTER/PRINT.
- The message " id " appears; now one should enter the weigh number (from 000000 to 131072) and press ENTER/PRINT.
- Now it is possible to view on the display the weigh information in sequence, and scroll through it with the ZERO key (ahead) or the TARE key (backwards):
  - "ch. x", in which x is the scale number (always 1).
  - " um yy" in which yy is the unit of measure (kg, g, t o lb).
  - gross weight (for about a second the message "GroSS" appears and then the gross weight value).
  - Tare weight (for about a second the message "tArE" appears or "tArEpt" if it is a manual tare; then the tare value appears).
- Press C to return to weighing.

**NOTES:**

- The alibi memory can store up to 131072 weighs; then the rewriting takes place from the beginning.
- If the alibi memory is empty, when the MODE key is pressed the message "EMPTY" appears for about a second, an error acoustic signal is enabled and one returns to weighing.
- If the entered ID is not valid, in other words, if there is no stored weigh relative to the entered ID, the message "no id" appears and an error acoustic signal is enabled and one returns to weighing.

**INITIALISATION OF THE ALIBI MEMORY**

It is possible to cancel all the weighs made, initialising the alibi memory; this operation can be made directly on the indicator (see the parameter "SETUP" >> "ini.AL" of the set-up environment, **TECH.MAN.REF.**) or through the serial command (see "SERIAL COMMANDS" below).

**NOTES:**

- It is not possible to just cancel a single weigh.
- The initialisation is possible only with a non approved instrument.

**SERIAL COMMANDS**

Besides the commands described in the section 7.5 – "FORMAT OF THE SERIAL COMMANDS", **TECH.MAN.REF.**, in this functioning mode also the commands below are available:

**WEIGH STORAGE**

**Command**

**[II]PID<CRLF> or <ESC>[II]PID<STX>**

**[II]PIDD<CRLF> or <ESC>[II]PIDD<STX>**

in which: [II]: 485 address  
 <ESC>: 27 ascii decimal character  
 <STX>: 2 ascii decimal character

Instrument response to the **[II]PID<CRLF>** command:  
**[II]PIDSS,B,LLLLLLLLLUU,YYTTTTTTTTTUU,(ID | NO) <CRLF>**

Instrument response to the **<ESC>[II]PID<STX>** command:  
**<ESC>[II]PIDSS,B,LLLLLLLLLUU,YYTTTTTTTTTUU,(ID | NO)<STX>**

Instrument response to the **[II]PIDD<CRLF>** command:  
**[II]PIDSS,B,LLLLLLLLLUU,YYTTTTTTTTTUU,(ID | NO),(dd/mm/yybbhh:mm:ss|"NO DATE TIME")<CRLF>**

Instrument response to the **<ESC>[II]PID<STX>** command:  
**<ESC>[II]PIDSS,B,LLLLLLLLLUU,YYTTTTTTTTTUU,(ID | NO),(dd/mm/yybbhh:mm:ss|"NO DATE TIME") <STX>**

In which:[II] 485 address (only when transmitting in 485 mode)  
 SS OL" (weight in overload) or "UL" (weight in underload) or "ST" (stable weight) or "US" (unstable weight) or "TL" (TILT input closed).  
 B scale number (always 1)  
 LLLLLLLLLL: gross weight on 10 digits  
 UU: unit of measure  
 YY: 2 spaces in the case of null tare or semiautomatic tare, "PT" in case of manual tare  
 TTTTTTTTTT: tare on 10 digits  
 ID XXXX-YYYYYY in which: XXXXX is the rewriting number (5 digits, from 00000 to 00255) and YYYYYY is the weigh number (6 digits, from 000000 to 131072).

dd/mm/yy Date in the "dd/mm/yy" format (only with PIDD command).  
 bb 2 space characters, 32 decimal ascii character (only with PIDD command).  
 hh:mm:ss Time in the "hh:mm:ss" format (only with PIDD command).

In the case in which the gross weight is negative or unstable, the weight is transmitted but not the ID; "NO" is in its place. In these cases there is no storage in the alibi memory.

In the case in which the date/time is not detected or set, the weight is transmitted but not the date and time; "NO DATE TIME" is in its place.

## WEIGH READING

### Command:

[II]ALRDXXXXX-YYYYYY <CR o CRLF>

In which: [II] 485 address (only when transmitting in 485 mode)  
XXXXX rewriting number (from 00000 to 00255)  
YYYYYY weigh number (from 000000 to 131072)

### Instrument response:

[II]B,LLLLLLLLLLUU,YYTTTTTTTTTTUU<CR o CRLF>

In which: [II] 485 address (only when transmitting in 485 mode)  
B scale number (always 1)  
LLLLLLLLLL gross weight on 10 digits  
UU unit of measure  
YY spaces in the case of null or semiautomatic tare, PT in the case of manual tare  
TTTTTTTTTT tare weight on 10 digits

## ALIBI MEMORY CANCELLATION (only with non approved instrument)

### Command:

[II]ALDL <CR o CRLF>

In which [II] 485 address (only when transmitting in the 485 mode)

### Instrument response:

[II]ALDLOK <CR o CRLF> if the cancellation has been effective

[II]ALDLNO <CR o CRLF> if the cancellation has not worked

NOTE: During the cancellation, the display shows "WAI" and all the indicator functions are "frozen".

The commands are ignored if one is not in the alibi memory functioning mode.

## 11.8 +/- TOLERANCE CHECK (ChEck)

In this functioning mode, the instrument commands the functioning of the SP1, SP2, SP3 and SP4 icons of the LCD display and the functioning of the 4 relais of the 2 expansion boards (optionals), on the basis of a freely programmed TARGET WEIGHT, a LOWER TOLERANCE value, an UPPER TOLERANCE value, and an ENABLING threshold.

------(thrESh)------(t.Min)-----TARGET WEIGHT------(t.MAX)-----

It is possible to carry out a check on the gross weight or the net weight: in the TECHNICAL set-up, after the selection of the Check mode, one is asked to select "GroSS" (gross weight) or "nEt" (net weight). The selection of the check type (net or gross), causes the configuration of the relay's relative default parameters.

By setting the threshold for activating the functioning mode, if the weight is under the set threshold, no check on the weight is made; if instead the weight reaches or surpasses the threshold, the check on the tolerances is enabled.

## ENTERING THE ACTIVATION THRESHOLD, TARGET AND THE TOLERANCES

- Press the **MODE** key; the instrument first shows "tArGEt" then "000000" or the target previously used. With the keyboard enter the desired target; with **C** one quickly zeros the entered value; by pressing **C** again one cancels the entry and returns to weighing.
- Confirm with **ENTER/PRINT**: the display shows first "t.Min" then "000000" or the T1 lower tolerance previously used. With the keyboard enter the desired lower tolerance; with **C** one quickly zeros the entered value; by pressing **C** again

one cancels the entry and returns to weighing.

- Confirm with **ENTER/PRINT**: the display shows first “t.MAX” then “000000” or the T1 upper tolerance previously used. With the keyboard enter the desired upper tolerance; with **C** one quickly zeros the entered value; by pressing **C** again one cancels the entry and returns to weighing.
- Confirm with **ENTER/PRINT**: the display shows first “thrESh” and then “000000” or the enabling threshold used previously. Through the keyboard enter the desired enabling threshold; by pressing **C** one quickly clears the entered value, while by pressing again **C** one cancels the entry and returns to the weighing mode.
- Confirm with **ENTER/PRINT**: the display shows “StorE” for an instant; after this it returns to weighing.

**NOTE:** If the entered value is wrong (i.e. tolerance value greater than the target or target greater than the scale capacity) the indicator emits a prolonged sound and zeros the entered value; furthermore, if a value different than the scale division is entered, it is rounded off to the nearest minimum division multiple.

## PROCEDURE

After having entered the activation threshold, the target and the tolerance values, put the weight on the scale: if the target is greater than 0, the display shows, at regular intervals, if the weight is within the entered tolerances:

| Scale                   | Display View | Enable Relay |
|-------------------------|--------------|--------------|
| Weight < Target – t.Min | _undEr       | reL.b.1      |
| Target – t.Min ≤ Weight | _oK –X       | reL.b.2      |
| Weight = Target         | -oK-         | reL.b.2      |
| Weight ≤ Target + t.MAX | ˆoK X        | reL.b.2      |
| Weight > Target + t.MAX | ˆoVEr        | reL.b.3      |
| Weight ≥ thrESh         |              | reL.b.4      |

**NOTE:** X is the difference (1 digit) between the weight on the scale and the target.

## ACOUSTIC SIGNAL

It is possible to enable an acoustic signal (beep) that is emitted when the weight is greater than the enabling threshold; the frequency with which the acoustic signal is emitted increases when the weight approaches the target and vice versa. When the weight reaches the target, the indicator emits a different acoustic signal.

To enable this function, press the keys “F” and “6” in sequence (in the 17-key indicators): the display shows “bEEP” and then “StorE”; to disable the function press again the keys “F” and “6” in sequence: the display shows “MutE” and then “StorE”.

In the 5-key indicators, it is possible to enable or disable the function only through DiniTools™ software (see the corresponding manual).

## TECHNICAL NOTES

- The 0 value is valid for the tolerances and for the activation threshold as well.
- By setting the target at 0 the weight check is disabled.
- If the printer has been configured and a target greater than 0 has been set, the target, tolerances, and check result will be printed.
- The check of the weight is active also during the modification of the target and the tolerances, according to the last confirmed values. The new entered values start working after having been confirmed.
- The 4 relays of the 2 expansion boards (optional) are automatically enabled depending on the mode selection, and may be used to manage external signals which show the operator whether the weight on the scale is INSUFFICIENT, CORRECT, ABUNDANT in comparison to the TARGET WEIGHT. Furthermore it is not possible to set the functioning mode of the relays, but just the status (NO / NC) and the type of check (direct or upon stability).
- It is possible to set the target, the tolerances and the activation threshold through the serial line, see section 7.5 - “FORMAT OF THE SERIAL COMMANDS”, **TECH.MAN.REF.**.



## 11.9 SAMPLE WEIGHT PERCENTAGE (PErC)

In this operating mode, the instrument shows on the display the net weight expressed as a percentage, comparing it with a reference weight which has been previously linked to a percentage.

When the functioning mode is selected, one is asked to set of:

### - "WAI.t" : sampling interval.

Setting of the sampling time (in seconds, with a decimal); greater is the time set and more precise will the sampling be.

- Set the desired time.
- Confirm with ENTER/PRINT.
- Press many times the C key until the display shows the message "SAVE?".

With the indicator fitted of a 17-key keyboard, by pressing the F and 7 keys, it's possible to change the sampling time also in the weighing mode. If the entered value is confirmed, it will substitute the one in the set-up environment.

## PROCEDURE

- 1) Place the empty container on the scale and press TARE to tare it.
- 2) Check that the zero is on the display and press MODE.
- 3) The display suggests a percentage; the possible options are: 100.0, 200.0, 5.0, 10.0, 20.0, 30.0, 40.0, 50.0, 60.0, 75.0.
- 4) Press "ZERO" or "TARE" several times to reach the desired sample size.
- 5) Put the reference weight on the scale and press ENTER/PRINT to confirm or C to cancel the operation and return to weighing.
- 6) Press ENTER/PRINT; the display will show "SAMPL". After a few instants the display will show the percentage selected put on the platform.
- 7) Add the quantity to be measured on the scale and the value will appear on the display.
- 8) By pressing the MODE key one switches from the display of the percentage to the display of the net weight and vice versa.
- 9) **To carry out a new sampling**, press at length the MODE key and repeat the operations as describe in point 3).

### "Er.Mot" ERROR DUE TO WEIGHT INSTABILITY DURING THE SAMPLING

It may happen that during the sampling phase the weight is unstable; the "Er.Mot" is shown remaining for about three seconds. One should therefore repeat the sampling operation.

### MINIMUM WEIGHT OF THE SAMPLE

It is necessary to use a net weight greater than 0.

### VARIABLE PERCENTAGE QUANTITY (only for 17-key indicator)

It is possible to insert directly by keyboard any percentage, different from the ones proposed by the MODE key:

- With the scale at zero, after having stored a tare, press "F"+ "5"; the display will indicate "n S" and then "0" or a quantity already stored.
- Modify and/or enter the quantity (max 3000.0) using the numeric keys.
- Follow the operations describe in point 5) in the **PROCEDURE** section.

## PRINTING

If the presence of a printer has been configured, each time ENTER/PRINT is pressed, while either weight or percentage are displayed, one prints the data programmed in the SEtUP >> SEriAL >> CoM.Prn >> Pr.ConF of the set-up environment (**TECH.MAN.REF.**); for example:

- GROSS weight
- TARE weight
- NET weight
- Percentage quantity on the scale in that moment.

NOTE: If the sampling has not been made, the quantity percentile is not printed.

## 11.10 SINGLE SCALE REPEATER (rEPE)

The system is made up of one or more indicators (named **REPEATERS**) which receive the data of the display or of the weight from another indicator or from a PC/PLC (named **TRANSMITTER**) and which therefore act as repeaters.

In the **REPEATERS** once this functioning mode has been set, one should configure the "rEPE.6", "rEPE.dC", "Pr1577" or "W.rEPE" parameter in the communication mode of the PC serial port (**SEtuP >> SEriAL >> CoM.PC** step (**TECH.MAN.REF.**)).

For further configuration and functioning details refer to the technical manual (**SEtuP >> SEriAL >> CoM.PC** step and section 7.4 - "SERIAL PORT TRANSMISSION MODES", **TECH.MAN.REF.**).

If "rEPE.6", "rEPE.dC" or "Pr1577" communication protocol has been set in the **REPEATER**, one will need to set the "rEPE.6" communication protocol in the **TRANSMITTER** on the desired port.

If "W.rEPE" communication protocol has been set in the **REPEATER**, one will need to set the protocol of the continuous weight transmission on the desired port of the **TRANSMITTER**.

For further configuration details refer to the technical manual of the connected indicator.

### FUNCTIONING

When the indicator is turned on it waits for the data; if it does not receive a correct communication string, the communication parameters are wrong, or it does not receive any character, it remains in the test condition, in other words, with all the central segments of the display turned on.

When the serial string of the connected instrument is identified, the indicator repeats the data of the display or the weight string of the instrument to which it is connected.

### CAREFUL:

- The keys pressed in the **REPEATER** are not repeated on the **TRANSMITTER** and vice versa.
- The indicator acts as a simple weight repeater: only the **C – ON/OFF** key is enabled for turning on/off.

### Example of Dini Argeo REPEATER/TRANSMITTER configuration:

|             | FunCt | PCModE | bAud | bit       |
|-------------|-------|--------|------|-----------|
| REPEATER    | rEPE  | rEPE.6 | 9600 | n – 8 - 1 |
| TRANSMITTER | (*)   | rEPE.6 | 9600 | n – 8 - 1 |

(\*) all functions (except "MAStr")

## 11.11 DISPLAY WITH SENSITIVITY X 10 (ViSS) (TO BE USED IN TESTING DURING THE CALIBRATION)

By pressing the MODE key one switches from the weight display with normal sensitivity to a sensitivity ten times greater; in fact, one will note that the last digit on the right of the display will have a sensitivity equal to the scale's division divided by 10.

The printout can only be done when the indicator has the standard sensitivity.

**TAKE NOTE:** In case the instrument is LEGAL FOR TRADE, when "MODE" is pressed, the sensitivity times 10 is displayed for five seconds after which the instrument returns to standard weight displaying. Furthermore, if the direct sales has been configured in the **SEtuP >> d.SALE** parameter, **TECH.MAN.REF.**, this displaying is possible only with if the capacity is equal or less than 100 kg (220 lb).

## 11.12 HOLD: FREEZING THE WEIGHT ON THE DISPLAY (hLd)

By pressing MODE, the value of the weight is held on the display, and the display shows hoLd alternately with the weight held value (every 5 sec). To release the weight value on the display, press MODE key again.

### 11.13 WEIGHT PEAKS DETECTION (PEAK)

It is possible to use the instrument to store the maximum weight value measured during the weigh (PEAK), useful to measure, for example, the breaking load of the materials.

By pressing the **MODE** key, the peak mode is enabled; on the LED display the maximum weight reached will be displayed, alternated with the message PEAK every 5 sec.

The test terminates by pressing the **MODE** key again or when the weight peak surpasses the maximum capacity of the instrument (for an instant PEAK.oF is displayed and the indicator returns to standard operation)

### SETTING SAMPLING TIME

It is possible to set the minimum time period of the peak impulse beyond which the measuring is accepted. This time is set by keeping "ENTER/PRINT" pressed for a few seconds when the indicator is not in the peak mode: the message **-tP-** appears on the display followed by a number which corresponds to the minimum time length of the impulse expressed in hundredths of seconds.

By pressing "ZERO" or "TARE" the following settable values are proposed: 1, 2, 3, 4, 5, 10, 20, 50, 100 and 127; press "ENTER/PRINT" to confirm the desired value, (the indicator will return to weighing). The default value is 2.

### TABLE OF OPERATING PARAMETERS IN PEAK MODE

| LENGTH | SAMPLINGS PER SECOND | ACQUIRED VALUES | MEDIATED VALUES |
|--------|----------------------|-----------------|-----------------|
| 1      | 400                  | 1               | 1               |
| 2      | 200                  | 1               | 1               |
| 3      | 100                  | 1               | 1               |
| 4      | 100                  | 4               | 2               |
| 5      | 50                   | 4               | 2               |
| 10     | 25                   | 4               | 2               |
| 20     | 12                   | 4               | 2               |
| 50     | 6                    | 4               | 2               |
| 100    | 6                    | 8               | 2               |
| 127    | 6                    | 12              | 2               |

### 11.14 HORIZONTAL TOTALIZER (Sum of lots) (tot 0)

**tot.Mod:** TYPE OF TOTALISATION (NORMAL, FAST, AUTOMATIC)

Once the totalizer operating mode is selected, both horizontal and vertical, one is asked to set the type of totalization: normal (t.norM), fast (t.FASt) or automatic (Auto); with ZERO or TARE one changes the parameter; with ENTER/PRINT one confirms.

- In the normal totalisation, for each accumulation operation there is the display of the weigh number and the net weight total, before the printing of the data.
- In the fast one, just the display of the "-tot-" message appears on the display, before the printing of the data.
- In the automatic one, there is the automatic acquisition of the stable weight; therefore the display of the "-tot-" message on the display and then the printing of the data.

**MAX.tot:** NUMBER OF CONSECUTIVE TOTALISATIONS AFTER WHICH THE TOTAL IS AUTOMATICALLY PRINTED AND RESET

After having carried out the set weighs, the accumulated general total is printed and reset; set a value between 0 and 63.

**NOTE:** the value 0 disables the function

### TOTALISATION OPERATIONS

In order to carry out the totalisation it is necessary to load the weight on the scale and press the MODE key (if the automatic totalisation has not been set): the weight is accumulated in two total levels (a partial total and a general total).

**To totalize, the net weight must be**

- at least 1 division with non approved instrument and with normal or fast totalisation;
- at least 10 division with non approved instrument and with automatic totalisation;
- at least 20 divisions with approved instrument.

To avoid undesired accumulations, the MODE key is active just once; it reactivates depending on the setting of the "rEACt" parameter in the SET-UP environment, in other words, either after passing by the net zero of the scale, by instability or

always (see section 9.12 - "REENABLING THE PRINTOUTS AND THE INDICATOR FUNCTIONS").  
If the presence of a printer has been configured, the MODE key causes also the printing of the weight values.

By pressing the MODE key again, **without having reenabled the totalisation**:

- with the normal totalizer, one can temporarily view on the display the number of weighs carried out and the PARTIAL NET TOTAL accumulated until that moment (Subtotal): if the accumulated digit is more than 5 digits the visualisation takes place in two stages.
- with the fast totalizer the " no.0.UnS " error message is displayed.

#### NOTE:

- If the gross or net weight is less or equal to zero, by pressing the **MODE** key the display shows the "LoW" error message.
- If the indicator is in the under load or over load status, by pressing the **MODE** key the display shows the "un.oVER" error message.

#### TOTALISATION WITH PRINTING

If the presence of a printer has been configured, upon each pressing of MODE, one prints the data programmed in step **SEtuP >> SEriAL >> CoM.Prn >> Pr.ConF** of the set-up environment (**TECH.MAN.REF.**), for example:

- Weigh number
- GROSS weight
- TARE weight
- NET weight

#### PRINTING AND ZEROING OF THE TOTALS

The instrument has two different total levels, a partial total and a general total, which increase upon each totalisation; these may be printed and zeroed independently from each other.

To print and zero the PARTIAL TOTAL one should press for an instant the ENTER/PRINT key; depending on the type of totalisation, various messages will be displayed:

- With **normal totalisation** the number of weighs and the accumulated total will be displayed.
- With **fast or automatic totalisation** the message "totAL" will be displayed.

The number of weighs made and the NET WEIGHT PARTIAL TOTAL are printed.

To print and zero the GENERAL TOTAL one should press for a few seconds the ENTER/PRINT key; depending on the type of totalisation; various messages will be displayed:

- With **normal totalisation** the number of weighs and the accumulated total will be displayed.
- With **fast or automatic totalisation** the message "G.totAL" will be displayed.

The number of weighs made and the NET WEIGHT GENERAL TOTAL is printed.

In the 17-key indicator, during the weighing, it is possible to view at any time the number of weighs and the accumulated net weight in the totals:

- By pressing for an instant the **6** key, the following will be displayed in this sequence:  
"n x", in which x is the number of weighs made  
"totAL", followed by the accumulated **PARTIAL NET TOTAL**.
- By pressing in sequence the **F** and **6** keys, the following will be displayed in sequence:  
"n x", in which x is the number of weighs made  
"totAL", followed by the accumulated **GENERAL NET TOTAL**.

#### MEMORY STORAGES (only for 17-key indicator)

It is possible to memorize the weigh totalisation in one of nine memory storages (identified from 1 to 9).

- Press in sequence the **F** and **5** keys; the display shows "rn n ":
- Enter the desired storage number (from 1 to 9).
- Now all the made totalisations are stored in the storage number just entered.
- To change the storage, repeat the same operations.

To recall or zero the PARTIAL TOTAL of a storage, it is necessary to recall first its identifying number, as previously described; however the GRAND TOTAL is not available for each storage.

**NOTE:**

- The selected storage remains active for all the following totalizations until it is substituted with another.
  - All the values accumulated in the single storage numbers are automatically zeroed each time the instrument is turned off.
  - When turned on, the indicator automatically goes to storage nr. 0 (not selectable).
- Storage nr. 0 is considered to be the basic one in which non-addressed weights are accumulated.

**11.15 VERTICAL TOTALIZER (Sum by recipe) (tot S)**

Like the horizontal totaliser but with each pressing of MODE the indicated weight is totalised and automatically tared; in this way it is possible for example to fill a container with various products.

**Note:** At the end of the totalisation operations, if one wants to view the gross weight on the scale one should press the **C** key.

**11.16 PIECE COUNTING (Coun)**

In this functioning mode it is possible to carry out the reference operations in order to use the scale for counting pieces. When the functioning mode is selected, one is asked to set some parameters:

- **"uM.APW" : unit of measure of the average unit weight (APW).**
  - Press ENTER/PRINT to enter the step.
  - With the ZERO or TARE keys select the unit of measure (*g / kg / t / Lb*).
  - Confirm with ENTER/PRINT.
  - Press many times the C key until the display shows the message "SAVE?".
  - Press ENTER/PRINT to confirm the changes made or another key to not save.

Independently from the unit of measure selected, the APW has always three fixed decimals.

- **"WAI.t" : sampling interval.**  
Setting of the sampling time (in seconds, with a decimal); greater is the time set and more precise will the calculated APW be.
    - Press ENTER/PRINT to enter the step.
    - Set the desired time.
    - Confirm with ENTER/PRINT.
    - Press many times the C key until the display shows the message "SAVE?".
- Press ENTER/PRINT to confirm the changes made or another key to not save.

**COUNTING PROCEDURE**

- 1) Place the empty container on the scale and press TARE to tare it.
- 2) Check that the zero is on the display and press the MODE button: the counting function is enabled.
- 3) The display suggests a REFERENCE QUANTITY. The possible options are: 5, 10, 20, 30, 40, 50, 60, 75, 100, 200.
- 4) Press "ZERO" or "TARE" the number of times needed to reach the desired sample size.
- 5) Put the quantity of pieces chosen for the SAMPLE on the scale and press ENTER/PRINT to confirm or C to cancel the operation and return to weighing.
- 6) Press ENTER/PRINT; the display will indicate SAMPL and the indicator will calculate the **Average Piece Weight (APW)**. After a few instants the display will indicate the quantity selected put on the platform.
- 7) Add the rest of the items to count in the container and whose value will appear on the display.
- 8) Unload the scale, the APW will remain stored in memory for the next counting of similar pieces, without having to repeat the REFERENCE operation.
- 9) By pressing the MODE key one switches from the display of the number of pieces to the display of the net weight and vice versa.
- 10) **To carry out a new reference operation**, press at length the MODE key and repeat the operations as describe in point 3).

**NOTE:** If the number of calculated pieces is greater than 999999, the display shows just the first 6 digits on the right.

## PIECE COUNTING IN EXTRACTION

- 1) Load a FULL container on the scale and press "TARE" to tare it.
- 2) Press "MODE": The display suggests various REFERENCE QUANTITIES: 5,10,20,30,40,50,60,75,100,200.
- 3) Press "ZERO" or "TARE" various times until the chosen quantity is displayed.
- 4) From the container take off the same number of pieces and press "ENTER/PRINT" to confirm. The display shows "SAMPL" while the indicator calculates the Average Piece Weight. The display shows in negative the quantity extracted.
- 5) Continue the counting in extraction.

### "Er.Mot" ERROR DUE TO WEIGHT INSTABILITY DURING THE SAMPLING

It may happen that during the sampling phase the weight is unstable and therefore it is not possible to correctly calculate the APW. The "Er.Mot" is shown remaining for about three seconds. One should therefore repeat the sampling operation.

### MINIMUM WEIGHT OF THE SAMPLE

It is advisable to use a reference quantity equal or greater than 0,1% of the scale capacity.

In any case, the weight of the reference quantity should not create an APW lower than the two internal points of the converter (intrinsic limit of the instrument); if this condition takes place, during the sampling, the display will indicate for an instant: "Error " and the quantity put on the plate will not be accepted. One should therefore use a higher reference quantity.

### VARIABLE SAMPLE SIZE (REFERENCE QUANTITY) (only for 17-key indicator)

It is possible to insert directly by keyboard any reference quantity up to 999999 (not only the quantities proposed by the MODE key).

- With the scale at zero, after having stored a tare, press "F"+ "5"; the display will indicate "n S" and then "0" or a quantity already stored.
- Modify and/or enter the quantity (up to 999999) using the numeric keys.
- Follow the operations describe in point 5) in the **COUNTING PROCEDURE** section.

### DISPLAY AND MODIFICATION OF THE AVERAGE PIECE WEIGHT (only for 17-key indicator)

It is possible to view or enter a known Average Piece weight using the keyboard. This can significantly speed up the reference operations.

- With the scale at zero, after having stored a tare, press "F" + "6", or the ENTER/PRINT key at length.
- The display will indicate " APW " and then "000.000" or a previously entered value expressed with three decimal digits in the programmed unit of measure.
- Enter the APW value with the keyboard (or leave the one present) and press ENTER/PRINT to confirm.

Example:

Unit of measure of the APW in g

000.000 means 000,000 g (for example APW = 001,050 = 1,05 g).

### PRINTING UNDER COUNTING MODE

If the presence of a printer has been configured, each time ENTER/PRINT is pressed, while either weight or pieces are displayed, one prints the data programmed in the **SEtuP >> SEriAL >> CoM.Prn >> Pr.ConF** of the set-up environment (**TECH.MAN.REF.**); for example:

- GROSS weight
- TARE weight
- NET weight
- Quantity of PIECES (PCS) on the scale in that moment.
- calculated APW, expressed in the set unit of measure, with three decimal digits

## 12. INDICATOR CONNECTED TO PRINTER, FUNCTIONING BY BATTERY

In a system made up of an indicator connected to a printer in which both are battery powered, the printer, normally in STAND-BY, will be powered only when one prints. When the printing is finished the printer returns to STAND-BY automatically. This functioning is useful to reduce the energy absorbed from the battery when the printer is not used.

In this configuration if one has the need to maintain the printer powered in order to replace the paper and for other operations:

- Press the ZERO key for a few seconds.
- On the display the blinking “onPri” message will appear.
- Press any key to exit.

**NOTE:** it is not possible to turn on the printer with the ZERO key in the REPEATER IN RADIO FREQUENCY functioning mode.

- The printer is now on; carry out the desired operations.

### 13. INSTRUMENT MESSAGES WHILE IN USE

| MESSAGE         | DESCRIPTION  |
|-----------------|--|
| <b>ZEr0</b>     | The scale is zeroing the weight.   |
| <b>AL.Err</b>   | It is displayed when one selects the alibi memory functioning mode, and upon start-up, the alibi memory is not connected or there are communication problems between the indicator and the board. The “unit of measure/pounds conversion” functioning is automatically set, but not saved in the set-up environment. |
| <b>Er.i.b.X</b> | A function has been linked to input X (from 1 to 4) and this is not present; see the “InPutS” parameter of the set-up environment ( <b>TECH.MAN.REF.</b> ).  |
| <b>Er.r.b.X</b> | In a set point functioning mode the relay X has been set (from 1 to 4) and this is not present; see the “outPut” parameter of the set-up environment ( <b>TECH.MAN.REF.</b> ).   |
| <b>buSy</b>     | Print under way (PRN serial port is occupied) or indicator waiting to transmit a printing to a PC.   |
| <b>unStAb</b>   | One is trying to print with an unstable weight.  |
| <b>un.oVER</b>  | One is trying to print with the weight in underload or in overload, in other words, with a weight of 9 divisions greater than the capacity or of 100 divisions below the gross zero.   |
| <b>LoW</b>      | Weight less than the minimum weight provided for the printing, the totalisation or the transmission of the string, standard or extended, upon pressing of the print key.   |
| <b>no.0.unS</b> | Weight not passed by net 0 or by instability.  |
| <b>ConV.</b>    | In standard mode, with approved instrument, one is trying to print while the instrument is converting the unit of measure.   |
| <b>no in</b>    | In the input/output mode (set as “in.out”), one is trying to acquire a second time the input weight.   |
| <b>no out</b>   | In the input/output mode (set as “in.out”), one is trying to acquire a second time the output weight.  |
| <b>no 1</b>     | In the input/output mode (set as “G.t.” or “1st.2nd”), one is trying to acquire a second time the input weight.  |
| <b>no 2</b>     | In the input/output mode (set as “G.t.” or “1st.2nd”), one is trying to acquire a second time the output weight.   |
| <b>Er.Mot</b>   | Unstable weight.   |
| <b>Error</b>    | In the counting mode, the sampling has not been made because one should use a higher reference quantity. In the equalization procedure, the cell that is being equalized is not the cell with the greater weight.  |
| <b>Eq.Err</b>   | It is displayed if it was not possible to perform the equalization.  |
| <b>StorE</b>    | It is displayed when data is stored in the permanent storage of the instrument (setpoint, tares, ticket progressive, etc.).  |
| <b>Err.CLk</b>  | Communication problems with the date/time of the indicator: check the <b>F.ModE</b> >> <b>CLoCk</b> step of the set-up ( <b>TECH.MAN.REF.</b> ).   |
| <b>SEt.CLk</b>  | Date/time not set: check the <b>F.ModE</b> >> <b>CLoCk</b> step of the set-up ( <b>TECH.MAN.REF.</b> ).  |
| <b>PrEC.</b>    | It is displayed if one tries to calibrate the zero point without first having confirmed the number of calibration points.  |
| <b>ErPnt</b>    | During the acquisition of a calibration point a null value has been read by the converter.   |
| <b>Err.rF</b>   | Selecting the “MASTER” functioning mode and enabled the energy saving mode, it is displayed when the indicator doesn’t detect the SLAVE for more than 60 seconds.  |

|                            |   |
|----------------------------|---|
| <b>Er – 11</b>             | Calibration error: a too small sample weight has been used; it is advisable to use a weight equal to at least half of the scale capacity.   |
| <b>Er – 12</b>             | Calibration error: the acquired calibration point (tP1 o tP2 o tP3) is equal to the zero point (tP0).   |
| <b>Er – 37</b>             | The number of converter points per scale division is less than two. Carry out again the calibration with special attention to the capacity and the division.  |
| <b>Er – 39</b>             | It is displayed when the instrument has not yet been calibrated and initialized.<br>Press the <b>TARE</b> key when the instrument displays “Er – 39” to enter the technical set-up environment. Carry out the initialization of the indicator (“dEFau” parameter) and the selection of the type of keyboard (“kEyB” parameter) and finally the programming of all the parameters of the set-up environment and the calibration. |
| <b>Er – 85</b>             | It is displayed when the instrument has been initialized but not yet been calibrated.<br>Press the <b>TARE</b> key when the instrument displays “Er – 85” to enter the technical set-up environment and carry out the calibration.  |
| <b>C.Er. – 36</b>          | During the calibration some internal negative points have been calculated: <ul style="list-style-type: none"> <li>- the calibration point is less than the zero point.</li> <li>- the signal is negative (check the connections).</li> </ul>  |
| <b>undEr</b><br>(blinking) | the weight in underload (i.e. a weight of 100 divisions below the gross zero, if the instrument is approved) is notified through this message and by an acoustic signal.  |
| <b>oVER</b><br>(blinking)  | the weight in overload (i.e. a weight o of 9 divisions greater than the capacity ) is notified through this message and by an acoustic signal.  |
| <b>ECo n</b>               | It is displayed for an instant if the master can connect to the slave n; if the connection is not possible, the message remains fixed and the master emits an acoustic signal.  |



## DECLARATION OF CONFORMITY

This device conforms to the essential standards and norms relative to the applicable European regulations. The Declaration of Conformity is available in the web site [www.diniargeo.com](http://www.diniargeo.com)

## WARRANTY

The TWO YEARS warranty period begins on the day the instrument is delivered. It includes spare parts and labour repair at no charge if the INSTRUMENT IS RETURNED prepaid to the DEALER'S PLACE OF BUSINESS. Warranty covers all defects NOT attributable to the Customer (such as improper use) and NOT caused during transport.

If on site service is requested (or necessary), for any reason, where the instrument is used, the Customer will pay for all of the service technician's costs: travel time and expenses plus room and board (if any).

the Customer pays for the transport costs (both ways), if the instrument is shipped to DEALER or manufacturer for repair.

The WARRANTY is VOIDED if any of the following occurs: repairs or attempted repairs are made by unauthorised personnel, connected to equipment installed by others, or is incorrectly connected to the power supply, or instrument has defects or damage due to carelessness or failure to follow the guidelines in this instruction manual.

This warranty DOES NOT provide for any compensation for losses or damages incurred by the Customer due to complete or partial failure of instruments, even during the warranty period.

## AUTHORIZED SERVICE CENTRE STAMP

