

The experience we've gained in electronics branch, mainly in the production of power supplies and the knowledge of the requirements of the market motivated us to extend the market offer to our products. Among them are devices operating the heating systems as follows: **temperature controller of the central heating solid fuel boiler, controller of the water jacket stove, controller of the conventional stove, controller of the blower rotations, controller of pumps and valves, and emergency AC power supply.** Their functions enable to fully make use of the capabilities of operated heating systems. They improve safety and decrease a fuel consumption. Besides, with small design changes they can be applicable to many uses in the heating and ventilation domain (e.g. in the heating system that is based on solar collectors).

CONTENTS

RT 08 G TATAREK Controller of the water jacket stove	2
RT 08 G BUFOR Controller of the water jacket stove with the graphic display	3
RT 08 G BUFOR-SOLAR Controller of the water jacket stove with the graphic display	4
RT 03 B WOJTUS Temperature controller for the c.h. pumps, dedicated to the water jacket stove	5
RT 08 K KOMINEK PLUS Temperature controller for the c.h. pumps and WAW (Warm Process Water), dedicated to the water jacket stove	6
RT 08 P KOMINEK LUX Temperature controller of the water jacket stove.....	7
RT 05 JACUS Automatic controller of rotations for the stove fan in systems of distribution of hot air (DGP)	8
RT 03 ARO Automatic controller of rotations for the stove fan in systems of distribution of hot air (DGP)	9
RT 10, RT 10N, RT-10L Rotations controller of the blower.....	10
RT 08 SAC Combustion controller with control of the air damper for stoves and stoves operating in heat accumulation systems.....	11
RT 08 OS Combustion optimizer of the conventional stoves with control of the air damper, or with heat accumulation	12
RT 08 OM Power optimizer of the conventional stoves with control of the air damper	13
RT 08 OS GRAFIK Combustion optimizer with graphic display of the conventional stoves with control of the air damper, or with heat accumulation	14
RP-01 PILOT Manual remote controller of the air damper	15
OTHER COMPONENTS of stove systems Peripheral devices that can cooperate with TATAREK stove automatics series	16
RT 14 PID Temperature controller of the central heating solid fuel boiler	17
RT 04 C PID Temperature controller of the central heating solid fuel boiler	18
RT 04 B PID „ADAŚ” Temperature controller of the central heating solid fuel boiler	19
RT 01 B PID „ANIA” Temperature controller of the central heating solid fuel boiler	20
RT 02 B PID „ANETA” Temperature controller of the central heating solid fuel boiler	21
RT 09 PID RETORTA Temperature controller of the central heating boiler with the feeder	22
TSP-100 Temperature controller of turning on the central heating circulating pump	23
RT 08 SOLAR Temperature controller of the heating system equipped with the solar collectors.....	24
RT-12 MIXER Temperature controller of the mixing valve	25
A 200 WAC Emergency power supply of the heating system.....	26
A 600WAC Emergency power supply of the heating system.....	27
RT-16 Controller of the heating system equipped with the solid fuel boiler.....	28

RT-08G TATAREK

Microprocessor controller with the graphic display for the heating systems based on the water jacket stove with a control of the air damper

■ **RT-08G TATAREK is a microprocessor controller** with the graphic display controlling the heating system (CH and WAW), in which the water jacket stove is a heat source. The operation of the stove is controlled by the air damper that controls combustion process. The main function of the controller is to keep up the temperature in the water jacket at the preset value. The process is mainly realized by gradually opening/ closing the air damper which, depending on the temperature of the water jacket, provides air to the combustion chamber. The RT08G controller is equipped with 3 temperature sensors. It ensures an automatic servicing of the CH, WAW- or buffer-based systems.

■ Basic functions of the controller:

- Smooth control of the air damper that provides air supply to the furnace, control of combustion process in the stove chamber
- Optimization of combustion process in the water jacket stove
- Control of the loading pump of the Warm Process Water (WAW) or buffer container
- Control of the 2 circulating pumps of the central heating (CH)
- Temperature hysteresis of switching on/off the pumps
- Visualization of all the parameters, operation modes and alarm situations of the stove on the LCD graphic display
- 3 temperature sensors (mounted on the water jacket, at the bottom and the top of the WAW or buffer container respectively)
- Blocking function of another heat source in a moment when the stove feeds heat into the system (nonvoltage contact)
- Protection of the WAW container against overheating (maximal temperature of the WAW switches off the loading pump)
- Integrated thermostat that allows selecting a proper range of WAW temperatures at the selected times of the day
- Capability of operation in the „SUMMER” mode implemented to only supply the WAW container
- Capability of operation without the WAW
- Capability of parallel operations of the CH and WAW systems (with WAW priority as well)
- Extending operation time of the WAW pump. It prevents abrupt temperature increases of the water jacket after ending loading the WAW container
- Capability of manual control of the air damper
- Automatic full closing of the air damper at the end of the burning, protecting the input and the rooms against cooling off
- Automatic full closing of the air damper in case of voltage decline in the mains
- Alarm of sensor damage and overheating of the system
- Function „Anti-stop” protecting the pumps outside the heating season
- Protection of the system against freezing
- Indication of the air damper locking, and in case of removing the cause there's a restoration of the previous settings
- Programmable memory of the CPU that allows in case of voltage decline restoring the original settings of the controller before the decline
- Selection of the language



■ RT-08G TATAREK



■ Air damper of the diameter 100, 120 or 150 Ø

Basic technical parameters:

Power	230V / 50Hz
Power consumption without load	5W
Maximum connection power	750W
Number of outputs to control pumps	3 *250W/230V/ 50Hz
Number of nonvoltage outputs	1
Number of outputs to control the air damper drive (RT-08G)	1 *5V/500mA/DC
Number of water temperature sensors	3 *KTY81 (0...+100°C)
Temp. measurement precision	2°C
Temp. measurement resolution	0,5°C
Number of the time zones	4
Fuse	6,3A / 250V
Protection class	IP41

APPLICATION

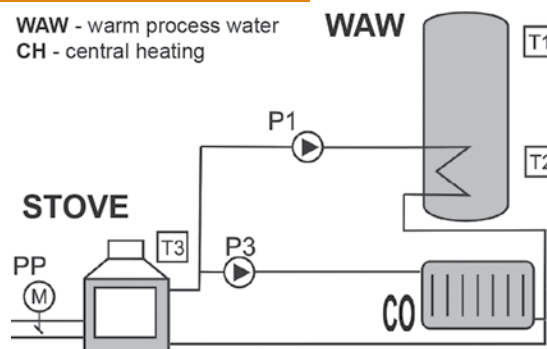

Microprocessor controller with the graphic display for the heating systems based on the water jacket stove with a control of the air damper

RT-08G BUFOR

RT-08G BUFOR is a microprocessor controller with the graphic display controlling the heating system (BUFFOR, CH and WAW), in which the water jacket stove is a heat source. The operation of the stove is controlled by the air damper that controls combustion process. The main function of the controller is to keep up the temperature in the water jacket at the preset value. The process is mainly realized by gradually opening/ closing the air damper which, depending on the temperature of the water jacket, provides air to the combustion chamber. The controller is equipped with 3 temperature sensors. It ensures an automatic servicing of the CH, WAW- or buffer-based systems.

Basic functions of the controller:

- Smooth control of the air damper that provides air supply to the furnace, control of combustion process in the stove chamber
- Optimization of combustion process
- Control of the loading pump of the Warm Process Water (WAW) and buffer container
- Control of the circulating pump of the central heating
- Temperature hysteresis of switching on/off the pumps
- Visualization of all the parameters, operation modes and alarm situations of the stove on the LCD graphic display
- 3 temperature sensors (mounted on the water jacket, on the WAW and buffer container respectively)
- Blocking function of another heat source in a moment when the stove feeds heat into the system (nonvoltage contact)
- Protection of the WAW and buffer container against overheating (Alarm of maximum temperature of the buffer and WAW)
- Integrated thermostat that allows selecting a proper range of WAW temperatures at the selected times of the day
- Capability of operation in the „SUMMER” mode implemented to only supply the WAW container
- Capability of operation without the WAW
- Capability of parallel operations of the CH and WAW systems (with WAW priority as well)
- Extending operation time of the WAW pump. It prevents abrupt temperature increases of the water jacket after ending loading the WAW container
- Capability of manual control of the air damper
- Automatic full closing of the air damper at the end of the burning, protecting the input and the rooms against cooling off
- Automatic full closing of the air damper in case of voltage decline in the mains
- Alarm of sensor damage and overheating of the system
- Function „Anti-stop” protecting the pumps outside the heating season
- Protection of the system against freezing
- Indication of the air damper locking, and in case of removing the cause there's a restoration of the previous settings
- Programmable memory of the CPU that allows in case of voltage decline restoring the original settings of the controller before the decline
- Selection of the language



RT-08G BUFOR



Air damper of the diameter 100, 120 or 150 Ø

Basic technical parameters are the same as for RT-08 G TATAREK

APPLICATION I

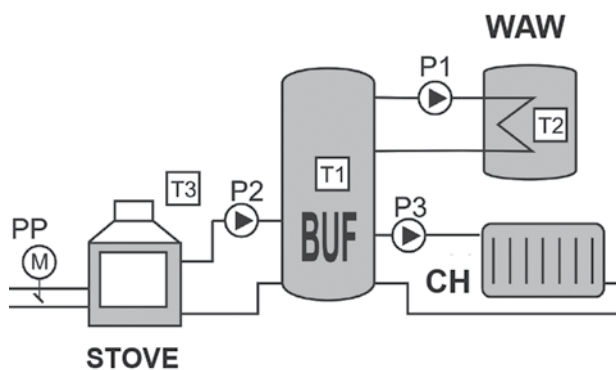

APPLICATION II

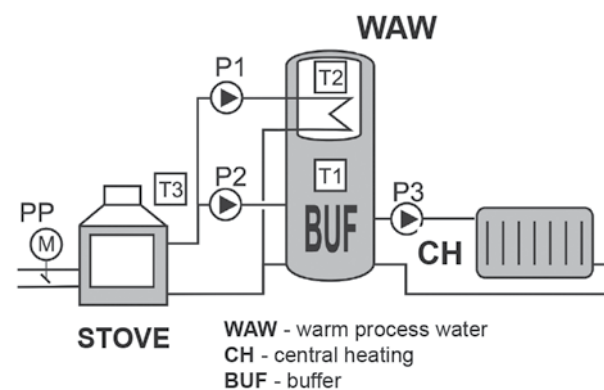

RT-08G BUFOR-SOLAR

Microprocessor controller with the graphic display for the heating systems based on the water jacket stove with a control of the air damper

RT-08G BUFOR-SOLAR is a microprocessor controller with the graphic display controlling the heating system CH based on the buffer container, in which the water jacket stove and solar collector are heat sources. The operation of the stove is controlled by the air damper that controls the combustion process. The main function of the controller is to keep up the temperature in the water jacket at the preset value. The process is mainly realized by gradually opening/ closing the air damper which, depending on the temperature of the water jacket, provides air to the combustion chamber. The controller is equipped with 3 temperature sensors. It ensures an automatic servicing of the buffer-based central heating (CH) systems with water jacket stove and solar collector.

Basic functions of the controller:

- Smooth control of the air damper that provides air supply to the furnace, control of the combustion process in the stove chamber
- Optimization of the combustion process in the water jacket stove
- Control of the loading pump of the buffer container from the water jacket stove side.
- Control of the circulating pump of the central heating
- Control of the loading pump of the buffer container from the solar collector side.
- Temperature hysteresis of switching on/off the pumps
- Visualization of all the parameters, operation modes and alarm situations of the stove on the LCD graphic display
- 3 temperature sensors (mounted on the water jacket, on the buffer container and solar collector respectively)
- Blocking function of another heat source in a moment when the stove feeds heat into the system (nonvoltage contact)
- Protection of the buffer container and solar collector against overheating (Alarm of maximum temperature)
- Protection of the solar collector has a higher priority than limiting the BUF temperature
- Capability of operation in the „SUMMER” mode implemented to only supply the buffer container without the CH pump
- Extending operation time of the buffer pump. It prevents abrupt temperature increases of the water jacket after ending loading the buffer container
- Capability of manual control of the air damper
- Automatic full closing of the air damper at the end of the burning, protecting the input and the rooms against cooling off
- Automatic full closing of the air damper in case of voltage decline in the mains
- Alarm of sensor damage and overheating of the system
- Function „Anti-stop” protecting the pumps outside the heating season
- Protection of the system against freezing
- Indication of the air damper locking, and in case of removing the cause there's a restoration of the previous settings
- Programmable settings memory of the CPU
- Selection of the language



RT-08G BUFOR-SOLAR



Air damper of the diameter 100, 120 or 150 Ø

Basic technical parameters:

Power	230V / 50Hz
Power consumption without load	5W
Maximum connection power	750W
Number of outputs to control pumps	3 *250W/230V/ 50Hz
Number of nonvoltage outputs	1
Number of outputs to control the air damper drive	1 *5V/500mA/DC
Number of water temperature sensors	3 *PT1000 (-50..+200 °C)
Temp. measurement precision	2°C
Temp. measurement resolution	0,5°C
Number of the time zones	4
Fuse	6,3A / 250V
Protection class	IP41

APPLICATION

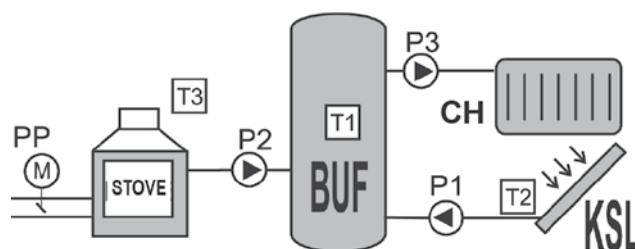

KSL - solar collector
CH - central heating
BUF - buffer

■ Microprocessor temperature controller RT-03B „WOJTUŚ” is a temperature controller designed for servicing heating systems equipped with stove inputs as well as stand-alone water jacket stoves or other heating solutions using water as a heat exchanger. It measures temperature in the water jacket of the stove and on base of pre-set data regulates the circulating pump motor and electromagnetic valve (based on individual temperature settings for each devices). Additionally it is equipped with a manually switched-on circuit handling the work of grill (if the stove is equipped with that kind of device) or other peripheral device the operation of which can be controlled by hand on the control panel (e.g. casing lighting, draught generator or extra pump).

The RT-03B controller was supplemented with the nonvoltage contact enabling to automatically switch off another heat source if the temperature of the water jacket reaches the pre-set limit value and the circulating pump motor starts operating. The temperature fall by 2°C below the limit value causes the pump turned off and a reswitching-on of the CH stove.

■ 2 systems implemented into the controller take care of the safety of the system:

- alarm system to prevent overheating (activated over 95°C)
- alarm system to prevent freezing of the system (the circulating pump runs at the temperature drop below 5°C).

■ The controller characterizes its compact design, small dimensions, what along with an ergonomic frame of the control panel allows its assembly to be done in any place in rooms without enclipping its esthetic values.

The controller increases the comfort of using of the water jacket heating systems with stove inputs and brings to a more economic usage of that kind of heating systems in residential areas.

Simple assembly and service as well as the possibility of configuration with many additional peripheral devices (casing lighting, draught generator or extra pump.) cause to get up its usage values. The controller RT-03B WOJTUŚ is an acclaimed product among jacket stoves’ producers and assemblymen of that kind of heating system, confirming its operational values and high quality guaranteeing a long-term, noncrashable device operation



■ RT-03B TITANIUM DESIGN



■ RT-03B Wojtuś STANDARD

Basic technical parameters:

Power	230V/50Hz
Power consumption	4W
Output load	3A/230V/50Hz
Temp. measurement range	0÷99°C
Temp. measurement error	0,5°C
Boiler temperature limitation	93°C
Range of temp. adjustments for pump and valve switch-on	5÷70°C
Alarm temperature	95°C
Fuse	3,15A/250V
Temperature sensor	Digital (company Dallas)

Basic functions of the controller:

- Control of the 2 circulating pumps of the central heating (CH)
- Switching off another heat source if the stove supplies heat to the system
- Additional circuit that enables to manually control the spit-roaster drive or another peripheral device e.g. casing lighting, draught generator or extra pump.
- Detection of sensor damage and overheating of the system
- Function „Anti-stop” protecting the pumps outside the heating season
- Protection of the system against freezing. Switching on the pumps at the temperature below 5°C
- Programmable memory of the CPU that allows in case of voltage decline restoring the original settings of the controller before the decline

APPLICATION

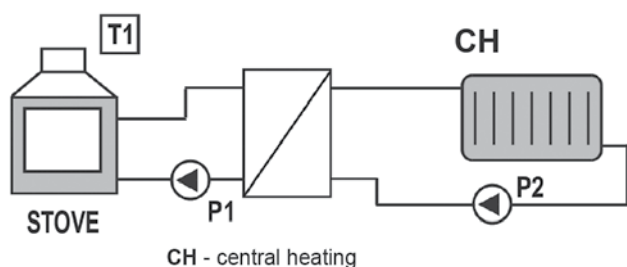

RT-08K KOMINEK PLUS

Microprocessor controller of the water jacket stove with the capability of controlling the warm process water container (WAW)

Microprocessor temperature controller RT-08K KOMINEK PLUS is the latest product of the company TATAREK dedicated to operate advanced heating systems supplied through the inputs of the water jacket stove, which also cooperate with the warm process water container (WAW).

The main functions of this controller is a fully automatic operation of the 2 circulating pumps CH, which is based on separate temperature settings for each of them and the loading pump of the WAW or buffer whose operation is controlled acc. to temperature measurements by 2 sensors of the WAW or buffer container.

The controller is an advanced version of the base model, that is, RT-03B WOJTUS for water jacket stoves. The improved controller is equipped with the control contact of the WAW loading pump with the WAW priority algorithm, which enables making use of that in advanced heating systems based on the water jacket input as a primary heating source.

It's noticeable that the controller can operate in the SUMMER mode, which enables to only operate the WAW loading pump without the need for the other CH pumps of the heating system to run.

The main change to the previous version is an integrated programmable thermostat. Thanks to it you can set individual ranges of temperature in the 4 time zones of the day. The controller has a backlit LCD display that shows all the data about the actual operation and utility functions subject to changes.

Equipment of the controller also includes an alarm circuit indicating temperature sensor damage and water overheating in the system, which apart from sound and light signals causes turning on both of the circulating pumps.

Like with the other products of the TATAREK company this controller has the algorithm of protecting the pumps against jamming if the system is not used for a long time (this function is only available with the controller switched on)

APPLICATION

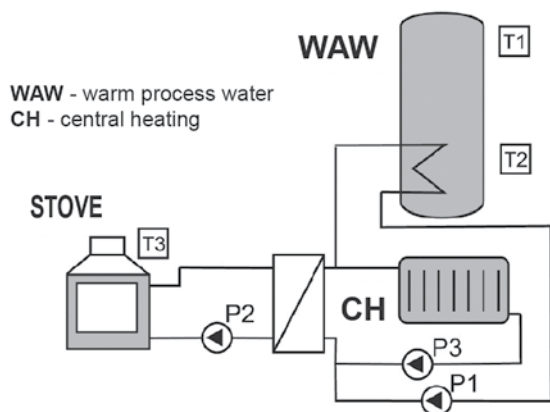

RT-08K TITANIUM DESIGN



RT-08K Kominek PLUS STANDARD

Basic technical parameters:

Power	230V / 50Hz
Power consumption (no load)	5W
Maximum connection power	750W
Outputs number to control pumps	3 *250W/230V/ 50Hz
Number of nonvoltage control outputs	1
Number of water temperature sensors	3 *KTY81 (0...+100°C)
Temp. measurement precision	2°C
Temp. measurement resolution	0,5°C
Number of time-zones	4
Fuse	6,3A / 250V
Housing protection class	IP41
Operation conditions	0÷50°C, humidity 10÷90% no condensation

Basic functions of the controller:

- Control of the pump loading the WAW container with the WAW priority or buffer container (Temperature measurements of water in the lower and upper part of the container)
- Control of the 2 circulating pumps of the central heating (CH)
- Switching off another heat source if the stove supplies heat to the system
- Integrated programmable room thermostat
- Capability of operation in the „SUMMER” mode implemented to only supply the WAW or buffer container
- Capability to configure the number of connected sensors
- Detection of sensor damage and overheating of the system
- Function „Anti-stop” protecting the pumps outside the heating season
- Protection of the system against freezing.
- Programmable settings memory of the CPU

Microprocessor temperature controller of the heating system based on the water jacket stove with air damper control

RT-08P KOMINEK LUX

■ Microprocessor temperature controller RT-08P TITANIUM is a device designed to operate the heating installations, in which the water jacket stove is a heat source and whose operation is regulated by the air damper that controls the combustion process.

■ The basic function of the controller is to maintain the temperature of the stove water jacket at the preset value, which is realized by opening the air damper supplying air into the combustion chamber based on the measured water jacket temperature. To the main functions of that controller also belongs the automatic control of the 2 circulating pumps CH dependent on the set temperatures for both of them and the loading pump WAW whose operation is steered by the measurements of 2 sensors located on the WAW or buffer container.

■ The air damper operation is based on the comparison of the set temperature and the real temperature in the water jacket. The difference controls the opening level of the air damper.

In one cycle the air damper opens by 10% (100% - full open). The specific LED on the control panel goes on every time when the air damper turns on.

Voltage decline or switching off the controller makes the air damper fully closed and the air supply to the combustion chamber is blocked.

■ The SUMMER mode is also integrated into the controller. The mode operates the loading pump of the WAW or buffer container without the necessity for the other pumps CH operating the heating system to run.

Another function is an integrated programmable thermostat, which enables to set temperature for each one of the 4 time-zones. The backlit LCD-display shows a complete data both about the actual state of the controller operation and the operational functions subject to changes.

■ The alarms indicate both the damage of any sensor and the system overheating, which apart from the audible and light signals causes both the 2 circulating pumps to operate in the continuous running and the air damper to be fully closed in order to ensure that the furnace be safely burned out.



■ RT-08P TITANIUM DESIGN



■ RT-08P Kominek LUX STANDARD

Basic technical parameters:

Power	230V / 50Hz
Power consumption (no load)	5W
Maximum connection power	750W
Outputs number to control pumps	3 *250W/230V/50Hz
Number of nonvoltage control outputs	1
Outputs number to control the air damper	1 *5V/500mA/DC
Number of water temperature sensors	3 *KTY81 (0...+100°C)
Temp. measurement precision	2°C
Temp. measurement resolution	0,5°C
Number of time-zones	4
Fuse	6,3A / 250V
Housing protection class	IP41

- Automatic full closing of the air damper at the end of the burning, protecting the input and the rooms against cooling off
- Alarm of sensor damage and overheating of the system
- Function „Anti-stop” protecting the pumps outside the heating season
- Protection of the system against freezing
- Indication of the air damper locking, and in case of removing the cause there's a restoration of the previous settings
- Programmable settings memory of the CPU

APPLICATION

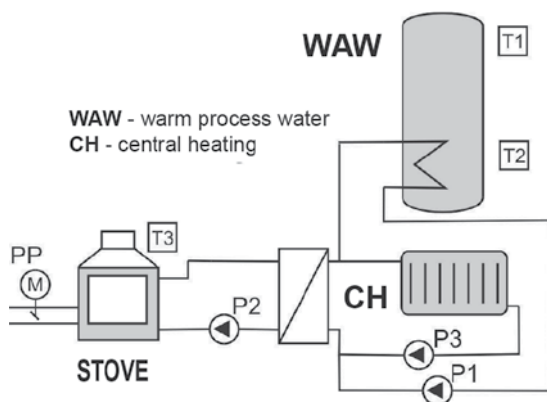

■ The controller is also available in the buffer version BUFOR

RT-05 JACUŚ

Temperature controller of rotations for the stove blowing fan in systems of distribution of hot air (DGP)

MICROPROCESSOR TEMPERATURE CONTROLLER OF MOTOR ROTATIONS FOR THE STOVE BLOWING FAN AND OTHER HEATING-AIRBLOW DEVICES OPERATING IN THE DISTRIBUTION-OF-HOT-AIR SYSTEMS.

■ MICROPROCESSOR TEMPERATURE CONTROLLER RT-05 „JACUŚ” is an innovative device finding application as a temperature controller in stove systems with the distribution of hot air (DGP) as well as in heating-airblow systems.

The controller is designed to operate with every kind of blower and airblow device in order to improve the efficiency of thermal exchange in rooms heated by the stove of the forced air circulation. It ensures a variable regulation of air forced-circulation in heated rooms on base of pre-set temperature adjustment demanded by the user.

The simplicity of assembly enables the controller to be used in already created systems and can work with every kind of air blower available on the market.

Outside the heating season by specific programming our controller can be applied for room ventilation with cool air by the forced circulation of any airblow appliance.

■ It consists of two components:

- **executive module**, which is a central controlling all the functions of the controller. It is mounted next to a fan/blower and apart from key tasks, it watches the circuit security protecting the fan motor from overheating.
- **control panel**, which is an actually single visible element of the whole set in which the measurement of room temperature is made. On this panel a user can set a desirable temperature and rotation speed of the blower.

■ Though RT-05 JACUŚ is brief enough on the market, its innovative approach to the theme of controlling with hot air won a lot of satisfied users both among producers of stove fans and individual clients giving them the possibility of full control over such a demanding heat carrier as air itself is.

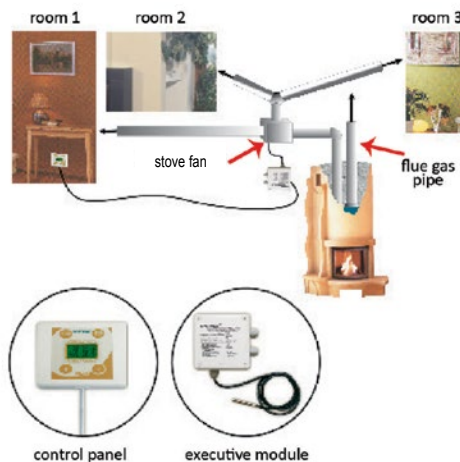

Basic technical parameters:

Power	230V/50Hz
Output load	3A/230V/50Hz
Maximum connection power	460VA
Operation temperature	0°C÷40°C
Measurement range of airblow temperature	0°C±155°C ± 5°C
Measurement range of room temperature	0°C±35°C ± 1°C
Switch-on temperature of alarm	145°C
Switch-off temperature of alarm	135°C
Variable regulation range of rotation	10%÷100%
Fuse	3,15A / 250V
Housing protection class	IP 55 (module)
Dimensions (w . x h . x l .)	110x30x80 (control panel) 115x50x115 (exec. module)

APPLICATION

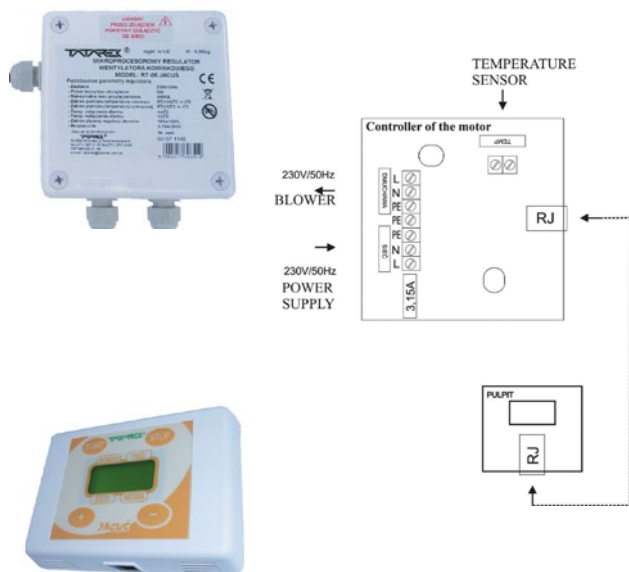

Basic functions of the controller:

- The controller controls temperature in the chamber of the blower motor and prevents it from a seizure by switching on the blower if temperature exceeds 145°C.
- In the operation mode of „rotation regulator” you can variably control rotations in the range of 10%...100% maximum rotation of the blower
- In the operation mode of „temperature regulator” you can stabilize temperature in the room in the range of 8°C ... 30°C by the variable regulation of a warm airblow

Temperature controller of rotations for the stove blowing fan in systems of distribution of hot air (DGP)

RT-03C ARO

MICROPROCESSOR TEMPERATURE CONTROLLER OF MOTOR ROTATIONS FOR THE STOVE BLOWING FAN AND OTHER HEATING-AIRBLOW DEVICES OPERATING IN THE DISTRIBUTION-OF-HOT-AIR SYSTEMS.

Microprocessor rotations controller RT-03C is designed to measure temperature in the chamber of a stove airblow fan and establishes its rotation speed steering the distribution of hot air.

The regulation of operation is based on two modes:

- manual (MAN)
- automatic (AUTO)

In the manual mode (MAN) you can manually set the rotation speed of the fan motor in the range of 0...10, where 0 means the switch-off of the motor and 10 maximum rotation. In this mode a temperature measurement doesn't affect the rotation.

In the automatic mode (AUTO) the rotation speed of the blower motor is automatically modulated to the temperature measurements. Over 40°C the fan starts working ensuring a minimum rotation available. The increasing temperature is proportionally related to the rotation reaching the maximum value at 80°C.

In the automatic mode the controller display shows measured temperature in the range of 0...99°C.

Over 99°C it shows „HI”. By clicking the „MAN” button you can at any time get control of the actual motor rotations. The working range of the controller can be adjusted to specific requirements of an individual blower motor doing the adjustments in the service mode by restricting its minimum and maximum rotations. Minimum turns (0) and maximal ones (99) mean the full range of rotation speed regulation (100%). Minimum turns can be elevated to the value 40 (40% of the full rotation), and maximum ones can be decreased to the value of 60 (60% of the full rotation of the motor).

If the mains is off (the switch SIEĆ or in case of voltage decline), the actual operation mode and set parameter are stored. After controller re-launching the values get restored.

The controller has got an alarm sound, which is activated in case of the damage of the temperature sensor or its wrong connection.



RT-03C TITANIUM DESIGN



RT-03C ARO STANDARD

Basic technical parameters:

Power	230V / 50Hz
Power consumption (no load)	4W
Load capacity of the blower output	1A / 230V / 50Hz
Operation conditions	0°C ÷ 50°C, humidity 10 ÷ 90% no condensation
Housing protection class	IP20
Thermal probe	KTY84
Maximum temp. of the probe	300°C
Temperature range	0°C ÷ 99°C
Temperature measurement error	1°C
Fuse	3,15A / 250V
Mounting	recessed install can P2 * 60
Dimension (w. x h. x l.)	148 x 80 x 55

APPLICATION



Basic functions of the controller:

- In the automatic mode the controller controls the range of rotations of a fan/blower engine. It depends on the settings of the pre-set temperature.
- In the manual mode the controller can manually control the range of 0...100% of the maximum rotation speed of the blower.
- The controller's got a service mode. In this mode you can adjust the application rotation range to the individual needs of selected types of blowers.

RT-10, RT-10L

Microprocessor rotations controller of the blower

■ MICROPROCESSOR ROTATIONS REGULATOR OF THE BLOWER RT-10 is designed for a precise regulation of rotation for different kind of blowers. It cooperates with blowers whose turns depend on the effective voltage put to the blower motor. Triac is an executive element that steers the actual rotation of the motor.

■ It's the simplest controller in the offer of the TATAREK company designed to control blower motors and supplements a spectrum of automatic controllers RT-03C ARO and RT-05 JACUŚ, which apart from a variable regulation of rotations realize tasks regarding temperature regulation.

The control panel shows rotations level by the lighting LEDs. If the controller is off, the LEDs are off. In the switch-on process the diodes gradually light up according to the actual rotation.

The increase of rotation is signalled at the start by the blinking LEDs beginning from the minimum level.

In the launch phase the intensity of the light impulses changes from short to more and more longer and in the end phase the LEDs light constantly. In that way the controller indicates the increasingly higher levels of blower rotations till the maximum value meaning the reaching of 100% power of the blower motor is achieved.

In the work you can change rotations at any time by pushing the button „+” or „-”.

■ The controller has also the service mode, in which you can select the type of motor. The option was applied in view of old motors used by some producers (described by RV), whose operation is possible only after a proper intervention in the service mode and should be done by an installer during the first run.

■ The controller RT-10 is an excellent completion of the TATAREK offer regarding controllers designed for ventilation systems and an innovative solution of the variable regulation of blower motors. It certainly gets up the comfort and economy of using such types of systems at minimum cost for control automatics.

■ This controller is available in 2 versions:

RT-10 underplaster and RT10N on-plaster. The TITANIUM version is only available as the underplaster one. The RT-10L controller is equipped with a digital display that shows the rotation speed where the digit 1 indicates 10% of the efficiency

Basic functions of the controller:

- Variable regulation of blower motor rotations
- On the control panel it displays information about the actual rotation speed of the blower
- It can operate with old motors used in blowers described as RV



■ RT- 10 and RT-10N STANDARD



■ RT- 10 TITANIUM DESIGN



■ RT- 10L TITANIUM DESIGN



Basic technical parameters:

Power	230V / 50Hz
Power consumption (no load)	1W
Maximum blower power	400W
Range of variable rotation regulation	10% ÷ 100%
Fuse	3,15A/ 250V
Dimensions (w. x h. x l.)	70 x 70 x 65

CHNNECTING – ASSEMBLY



■ The controller RT-08 SAC is a device suited to operate heating sources in heat accumulation systems, whose task is to optimize the combustion process and maintain for as long as possible the embers phase in order to obtain maximum heat energy from fuel and send it to accumulation elements and protect them from prematurely losing that energy.

■ Variable regulation of the air damper that supplies air to the furnace (the air damper is a main device of the combustion proces) is based on measuring temperature of the area directly above the furnace chamber by the flue gas temperature sensor. It allows to most efficiently select a proper dose of air for obtaining maximum heat energy from fuel. Additionally the controller operates the chimney flap drive (e.g. Moritz) to increase a chimney draught during the firing-up phase and if need be, bypassing the circulation of accumulation elements in the burnout phase what prevents them from cooling off.

■ The controller is equipped with its own alarm module, which causes the air damper to fully open up and a full burnout of the fuel input. The alarm situation is indicated by sound and light signal (the red LED on the control panel). Because of this kind of furnace specificity the controller has got the free relay contact that allows for connecting any CO detector close to the furnace. In this model an extra programmable relay was used, thanks to that you can operate other devices working in the system (e.g. auxiliary heating, ventilation).

■ The controller has a capability to cooperate with the door sensor of the furnace in order to fully automate the burning process in the heat accumulation system.



■ RT-08 SAC TITANIUM DESIGN



■ RT-08 SAC STANDARD

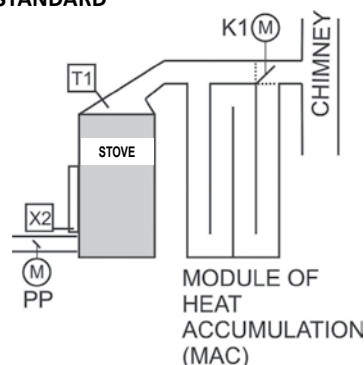

Basic functions of the controller:

- Optimizes and controls the combustion process by variably controlling the air damper that supplies air to the combustion chamber based on the temperature of the flue gas
- Extends a lot the combustion process and breaks between each refuel. It informs about the need for refuelling
- Indicates a combustion error caused by e.g. wet fuel, wrong chimney draught, flame putting out.
- Decreases fuel consumption up to 30% yearly.
- Improves the efficiency and safety of the heating system
- Controls the drive of the chimney flap (e.g. Moritz)
- Shuts off air supply to the furnace after the burning ends. It prevents the input and rooms from cooling off.
- Has a backup UPS-like power supply that maintains the air damper operation in case the mains is down (the air damper and chimney flap open up)
- Cooperates with a CO detector
- Cooperates with the door sensor of the furnace
- Turns on/off other devices cooperating with the system (auxiliary heating, ventilation and the like)

Basic technical parameters:

Power	230V / 50Hz
Auxiliary power	Battery 4,8V/60mAh
Power consumption without load	5W
Maximum connection power	250W
Operation conditions	0-40 °C, humidity 10-90% no condensation
Housing protection class	IP41
Fuse	6,3A/ 250V
Number of outputs to control the flap drive	1 * 250W/230V/50Hz
Number of nonvoltage outputs	1 * NO and NC contacts
Number of outputs to control the air damper drive	1 * 5V/500mA/DC
Number of temperature sensors	1 * thermocouple type (0...+1300 °C)
Temperature measurement precision	5 °C
Temperature measurement resolution	1 °C

RT-08 SAC microprocessor controller of the stove with heat accumulation system

RT-08 OS

Combustion optimizer of the conventional stoves, with heat accumulation and water attachment

■ The controller RT-08 OS optimizes the combustion process in the furnaces equipped with a direct air supply to the combustion chamber.

Thanks to the temperature measurement made directly above the combustion chamber you can achieve the most efficient regulation of the air supply, what along with right algorithms of control allows to optimize the burning process and therefore a more economic use of the heat obtained in this process. It can operate the heat accumulation module and water attachment in parallel, which is also applicable to this kind of systems.

■ Variable regulation of the air damper that supplies air to the furnace (the air damper is a main device of the combustion process) is based on measuring temperature of the area directly above the furnace chamber by the flue gas temperature sensor. It allows to most efficiently select a proper dose of air for obtaining maximum heat energy from fuel. Additionally the controller can operate the chimney flap drive (e.g. Moritz) to increase a chimney draught, transfer heat energy of the flue gas to the accumulation elements or water attachment.

Basic functions of the controller

- Optimizes and controls the combustion process by variably controlling the air damper that supplies air to the combustion chamber based on the temperature in the furnace
- Restricts the maximum temperature of combustion
- Extends a lot the combustion process
- Decreases fuel consumption
- Extends an exploitation time of the stove input
- Improves safety of the stove system
- Boosts the efficiency and heat comfort of the heating system
- Shuts off air supply to the furnace after the burning ends. It prevents the furnace from cooling off.
- Makes scavenges of the combustion chamber in the burnout phase to get rid of excessive flue gas.
- Available diameters of the air damper: 100, 120, 150mm
- Temperature sensor of the flue gas up to 1300°C
- Optimal use of the water attachment with the operation of the loading pump of the buffer (option)
- Cooperates with a CO detector (opening the chimney flap and air damper in case of alarm, activating an additional peripheral device e.g. draught fan. Acoustic alarm)
- Has a backup UPS-like power supply that maintains the air damper operation in case the mains is down (the air damper opens up)
- Capability to set individual parameters in terms of the heating input and protect them with a password.
- Controls the flap operation that regulates a chimney draught
- Cooperates with the door sensor of the furnace
- Informs about the need for refuelling



■ RT-08 OS TITANIUM DESIGN



Diagrams of basic operation

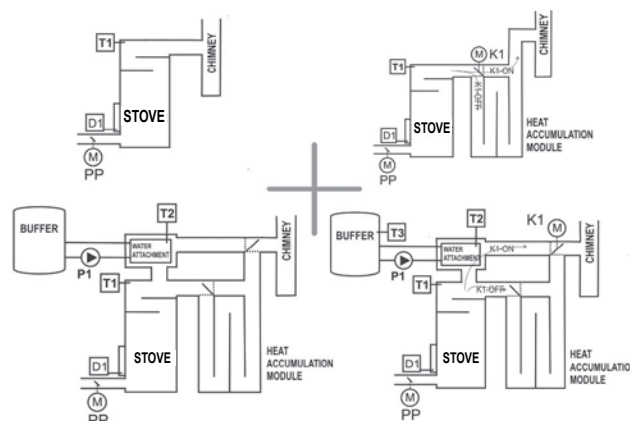

Basic technical parameters:

Power	230V / 50Hz
Auxiliary power	Battery 4,8V/60mAh
Power consumption without load	5W
Maximum connection power	250W
Fuse	6,3A/ 250V
Number of nonvoltage outputs	1 * NO and NC contacts
Number of outputs to control the air damper drive	1 * 5V/500mA/DC
Number of outputs to control the pump	1 * 230V/50Hz/AC
Number of temperature sensors of flue gas	1 * thermocouple type (0...+1300 °C)
Number of outputs to connect water temperature sensors	2 * KTY (0...+100 °C)
Temperature measurement precision	5 °C
Temperature measurement resolution	1 °C

■ The RT-08OM controller is dedicated to the optimization of combustion power of the stove

It's a device designed for operating traditional stoves and air ones, whose task is to optimize the combustion power of the stove.

There're 3 temperature-defined power ranges selectable for a specific furnace:

- -minimum
- -medium
- -maximum

in order to most efficiently transfer the received heat to the room.

■ Smooth control of operation of the air damper, which feeds air to the furnace and is the main component affecting the combustion process, is based on the measurement of the temperature above the furnace chamber by the flue gas temperature sensor. It allows to supply a proper amount of air that is essential in the combustion process for receiving from fuel a thermal energy at the user's preset level of stove power.

■ The controller is equipped with an alarm module that opens up fully the air damper in case the power supply is off in order to completely burn out the furnace feed as soon as possible. Any alarm situation is accompanied by a sound and light alarm (a red LED on the control panel). On account of the specifics of that kind of furnace the controller is equipped with a free relay contact to connect to any CO-concentration measurement gauge close to the furnace. In this model an additional programmable relay was integrated that enables to control other devices of the system (e.g. auxiliary heating, ventilation).

■ The controller enables the cooperation with the furnace door's sensor.

Basic functions of the controller:

The controller:

- optimizes the combustion process by controlling the air damper that feeds air to the combustion chamber based on the flue gas temperature.
- ensures the comfort of the combustion process that is adjustable to the preset power of the stove. It keeps you informed about the need for refuelling.
- informs about combustion errors caused by e.g. wet fuel, wrong chimney draught, the flame being put out.
- decreases the fuel consumption by up to 30% a year
- prevents the furnace from overheating
- improves the performance and safety of the heating system
- closes off air supply to the furnace chamber after the combustion is finished, prevents the fuel feed and rooms from cooling off.
- has an auxiliary power supply that maintains the operation of the air damper in case the mains is down (emergency opening of the air damper).
- cooperates with any CO-concentration measurement gauge
- cooperates with the furnace door's sensor
- switches on/off other devices cooperating with the system (auxiliary heating, ventilation and such).



■ RT-08 OM TITANIUM DESIGN



Diagram of basic operation

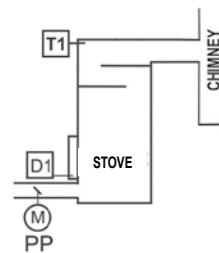

T1 - Temperature sensor of the combustion
 D1 - Sensor of opening the furnace door (option)
 PP - Controlled air damper

Basic technical parameters:

Power supply	230V / 50Hz
Auxiliary power supply	Battery 4,8V/60mAh
Power consumption without load	5W
Maximum connection power	250W
Operation conditions	0-40 °C, humidity 10-90% no condensation
Protection class	IP41
Fuse	6,3A/ 250V
Nonvoltage control outputs	1 * contact NC and NO
Number of outputs controlling the drive of the air damper	1 * 5V/500mA/DC
Number of temperature sensors	1 * Thermocouple type K (0...+1300 °C)
Measuring accuracy of temperature	5 °C
Resolution of temperature measurement	1 °C

RT-08 OS GRAFIK

Combustion optimizer in the conventional stoves or with heat accumulation

■ The controller RT-08 OS GRAFIK optimizes the combustion process in the furnaces equipped with a direct air supply to the combustion chamber.

Thanks to the temperature measurement made directly above the combustion chamber you can achieve the most efficient regulation of the air supply, what along with right algorithms of control allows to optimize the burning process and therefore a more economic use of the heat obtained in this process. It can operate the heat accumulation module and water attachment in parallel, which is also applicable to this kind of systems.

■ Variable regulation of the air damper that supplies air to the furnace (the air damper is a main device of the combustion process) is based on measuring temperature of the area directly above the furnace chamber by the flue gas temperature sensor. It allows to most efficiently select a proper dose of air for obtaining maximum heat energy from fuel. Additionally the controller can operate the chimney flap drive (e.g. Moritz) to increase a chimney draught, transfer heat energy of the flue gas to the accumulation elements or water attachment.

Basic functions of the controller

- Optimizes and controls the combustion process by variably controlling the air damper that supplies air to the combustion chamber based on the temperature of flue gas
- Restricts the maximum temperature of combustion
- Extends a lot the combustion process
- Decreases fuel consumption
- Extends an exploitation time of the stove input
- Improves safety of the stove system
- Boosts the efficiency and heat comfort of the heating system
- Shuts off air supply to the furnace after the burning ends. It prevents the furnace from cooling off.
- Makes scavenges of the combustion chamber in the burnout phase to get rid of excessive flue gas.
- Available diameters of the air damper: 100, 120, 150mm
- Temperature sensor of the flue gas up to 1300°C
- Optimal use of the water attachment with the operation of the loading pump of the buffer (option)
- Cooperates with a CO detector (opening the chimney flap and air damper in case of alarm, activating an additional peripheral device e.g. draught fan. Acoustic alarm)
- Has a backup UPS-like power supply that maintains the air damper operation in case the mains is down (the air damper opens up)
- Capability to set individual parameters in terms of the heating input and protect them with a password.
- Controls the flap operation that regulates a chimney draught (T-pipe Moritz)
- Controls the draught generator
- Cooperates with the door sensor of the furnace
- Informs about the need for refuelling
- Has a capability to connect another temperature sensor of flue gas (only readyonly mode).



■ RT-08 OS TITANIUM DESIGN



Diagram of basic operation

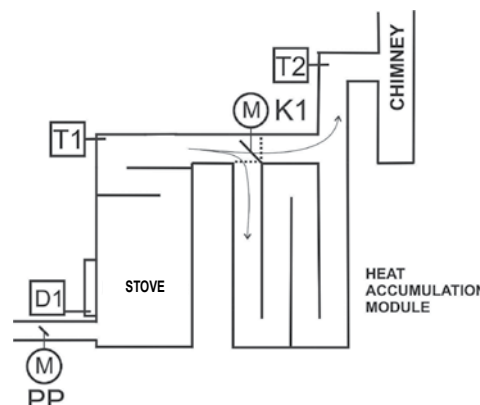

Basic technical parameters:

Power	230V / 50Hz
Auxiliary power	Battery 4,8V/60mAh
Power consumption (no load)	5W
Maximum connection power	250W
Fuse	6,3A/ 250V
Number of control nonvoltage outputs	1 * NO and NC contacts
Number of outputs to control the air damper	1 * 5V/500mA/DC
Number of outputs to control the pump	1 * 230V/50Hz/AC
Number of temperature sensors of flue gas	1 * Thermocouple K (0...+1300 °C)
Number of outputs to connect the flue gas sensor	2 * Thermocouple K (0...+1300 °C)
Temperature measurement precision	5 °C
Temperature measurement resolution	1 °C

■ THE CONTROLLER RP-01 OF THE AIR DAMPER is the simplest solution ensuring a remote controlling of the air damper that delivers air to the combustion chamber.

The set includes the following devices:

- Air damper that variably controls the air supply
- Executive module and charging module that charges batteries of the backup power supply
- Receiver of signals from the remote controller
- Remote controller
- Rechargeable battery of the UPS-like backup power supply

The remote controller itself is equipped with the LED curved strip indicating the opening angle of the air damper, which allows to observe a current operation of the air damper. The controller is also equipped with a battery-based backup power supply with the function of its charging when there's power supply in the mains. The backup power supply ensures an operation of the air damper when the power is off.

■ The controller RP-01 is a basic kind of regulation for any sort of furnaces, for which the air supply needed for combustion process is delivered through the supplying channel. It also enables to remotely control the combustion process from any distance ensuring the communication reach to the executive module. The actual reach range of the remote controller in residential buildings equals up to 20m with a wide angle of the beam signal. The executive module can be mounted at any place (e.g. in the walls of a stove) within a distance of no more than 6m from the air damper (standardly the cable is 3m long). The only device that must be placed in a visible place is the infrared receiver receiving signals from the remote controller.

■ This controller is an excellent solution for any kind of furnace, in which it's not required to use an automatic regulation of the combustion process and for the user that wants a direct control over the flame - especially in standalone stoves and classic ones distributing hot gravitational air. It enables to get rid of one of the most unreliable elements of mechanical air dampers, that is, the pull rod for manual regulation.



■ Remote controller



■ Executive module



■ Air damper of the diameter 100, 120 or 150 Ø

Basic technical parameters:

Power	230V / 50Hz
Auxiliary power	Battery 12V/1,3Ah
Power consumption without load	5W
Operation conditions	0-40 °C, humidity 10-90% no condensation
Housing protection class	IP41
Fuse	500mA/ 250V
Number of outputs to control the air damper drive	1 * 5V/500mA/DC
Power of the remote controller	Li-battery 3V CR2025

Basic functions of the controller:

- Remote control of the angle of the air damper movement
- Controller informs about the actual angle value on the control panel.
- Controller allows the combustion process to be controlled by decreasing or increasing the air supply to the furnace.
- Controller ensures a remote controlling without the need for additional elements mounted in the open view.
- Controller ensures an emergency operation of the air damper during power supply decline.

Diagram of basic operation

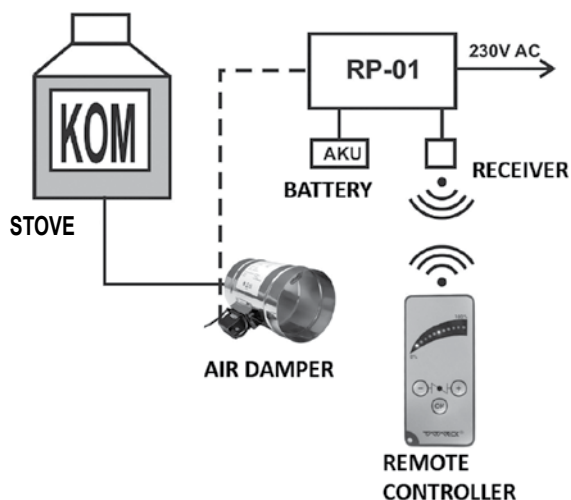

Other components of stove systems

Peripheral devices that can cooperate with TATAREK stove automatics series: RT-08OS, RT-08OM, RT-08SAC.

Home CO detector DDCH-N.P.



■ Home CO detector GAZEX DDCH-N.P continuously detects the CO concentration (carbon monoxide) in rooms exposed to the dangerous gas. The detection is based on a cyclical measurement of the CO concentration. If the preset limit value of CO and the exposition time are reached, the detector emits alarm sound and flashing light. The alarm switches on if the concentration is over 0,005% CO and the exposition time is over 60 min or if the concentration is 0,01% CO and the exposition time is 10 min or if the concentration is 0,03% CO and the exposition time is 3 min (according to the European Standard PN-EN 50291). It's got an extra output to connect an additional alarm horn and an output to connect TATAREK controllers, blower or extra alarm system.

Chimney 2-way T-Pipe 90°

■ The chimney T-Pipe directs the flow of flue gas in the stove systems and is mainly applied in heat accumulation systems. The T-Pipe also named Moritz is made of heat-resisting sheet CrNi 1.4828, sheet gauge 2mm, thermal resistance 1000°C, diameter DN 180. You can connect up the BELIMO servomotor, thanks to this the T-Pipe can be controlled by TATAREK stove controllers.



Servomotor BELIMO TF230 with assembly kit ZG-TF1



■ Servomotor BELIMO TF230 with the return spring (Open/ Closed) powered by 230V along with the assembly kit ZG-TF1 is used to connect the chimney T-Pipe with a TATAREK stove controller. It's mainly applied in heat accumulation systems where it automatically directs a flue gas flow at the preset temperature or during any alarm situation or voltage decline of the mains.

Sensor of opening the stove door

■ Sensor of opening the stove door TATAREK is a magnetic reed relay to optimize the combustion process in the stove. It's mounted on the furnace door and with a TATAREK stove controller ensures a comfortable operation of the stove. Everytime the stove door opens the sensor informs the TATAREK controller about the combustion interference and enables an automatic adjustment of the combustion parameters to the actual situation in the furnace. The thermal resistance of the sensor is up to 200°C. The silicone cable is 4m long.



■ The RT-14 PID controller is a device designed to operate the CH solid fuel boiler in terms of stabilizing the boiler operation based on a temperature measurement of water. It controls the blower, circulating pump CH, pump WAW and servomotor of the 3-way valve.

Basic functions of the controller

- Control of the air blower (2 operation modes: variable control of rotation, or on/off)
- Realization of temporary scavenges of the boiler
- Control of the circulating pump CH
- Control of the loading pump WAW in parallel with the CH, with WAW priority, function SUMMER (only WAW) or it's switched off
- Control of the 3-way valve with the pump in different configurations (e.g. protection of the boiler return, floor heating, heaters)
- PID algorithm that can be turned off
- Safety thermostat STB
- Temperature sensor of the boiler, mixing valve and WAW container or buffer.
- During an alarm situation the controller decreases the boiler temperature by switching off the blower and switching on the pump CH
- Protection of the system against getting frozen. Switching on the pump if the boiler temperature drops below 5°C
- Function „AntiStop” (cyclical switch-on of the pumps) preventing the stone from settling outside of the heating season
- Light and sound alarm
- Capability to connect any room thermostat
- Cyclic realization of pump rundowns outside of the heating season to protect the rotor from jamming (turning it on once a week for 1min)
- Memory of recently applied settings after power supply decline
- LCD display informing about boiler and heating system operation
- Wide setting ranges of operation of all the devices (modulation of the blower, times and pauses of scavenges, temperature ranges of the pumps and valve)
- Selection of the language

CH - Central heating

APPLICATION

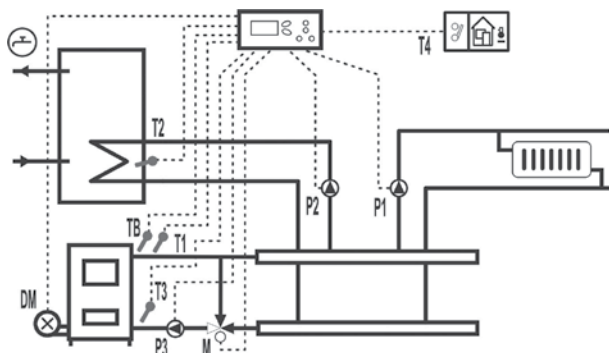

■ Controller is available

1. in the panel version for mounting in the casing of the boiler or
2. in the metal housing !

Basic technical parameters:

Power	230V / 50Hz
Power consumption without load	4W
Maximum connection power	750VA
Operation conditions	0°C ÷ 50°C
Power-carrying capacity of blower output	1,5A/230V/50Hz
Number of outputs to control the pumps	3 * 200W/230V/50Hz
Number of outputs to control the valve motor	2 * 200W/230V/50Hz
Range of temperature measurement	0°C ÷ 100°C
Number of temperature sensors of water	3 * KTY81 (0...+100 °C)
Operation modes of the blower	3
Temperature measurement precision	+/- 1°C
Limit of the boiler temperature	93°C
Switch-on temperature of the STB safety thermostat	94°C
Setting range of temperature	40÷90°C
Rotations of the blower	10%÷100%
Scavenge time	5÷60s
Scavenge pause	2÷10 min
Temperature of the burnout phase	35°C
Output with the nonvoltage relay to compatible room thermostat	

RT-04C PID

Microprocessor temperature controller of the central heating solid fuel boiler

Microprocessor temperature controller RT-04C PID is a device to operate the c.h. solid fuel boiler in the domain of stabilizing the boiler operation based on water measurement.

The controller controls the c.h. system with the solid fuel boiler, in which by variably controlling the efficiency of the blower the boiler temperature changes. Additionally the operation of the c.h. circulating pump is controlled.

Advantages of the PID algorithm:

- significant saving on the fuel
- stable temperature of the flue gas
- stable water temperature of the boiler
- longer life of the boiler
- no condensation

Options of the PID algorithm:

- standard
- extended (forcing a continuous operation of the blower)

Basic functions of the controller RT-04C:

- Temperature sensor of the c.h. boiler with an integrated safety thermostat STB.
- Acoustic and visual information of any alarm situation
- Storing any alarm situation in memory even after switching off the power.
- During any alarm the controller decreases the boiler temperature by switching off the blower and switching on the c.h. circulating pump
- Rundowns of the pumps beyond the heating season once a week for 1min
- Protection of the system against getting frozen, alarm switch-on of the pump at a boiler temperature drop below 5°C.
- **Operation modes of the blower motor**
 - variable regulation of rotations
 - variable regulation of rotations of the motor class RV-14
 - lack of variable rotations, operation ON/OFF
- Capability to adjust the controller to the blower motor (virtually to any motor)
- Low energy consumption of the controller due to a modern microprocessor
- LED display.
- Intuitive operation.
- Small, ergonomic casing made of high quality materials.
- A stand enabling an easy assembly on the boiler

APPLICATION

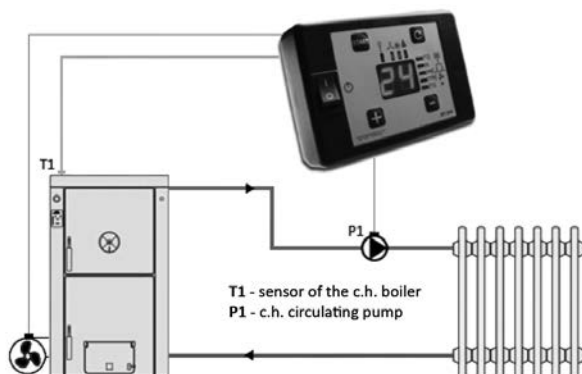

Basic technical parameters:

Power	230V/50Hz
Power consumption without load	4W
Maximum connection power	580W
Operation conditions	0÷40°C, humidity 10÷80% no condensation
Control output of the circulating pump CH	1A / 230VAC
Control output of the blower	1,5A / 230VAC variable regulation of rotations
Efficiency of the blower	10% - 100%
Safety thermostat of the boiler STB	94°C
Electronic limit temperature of the boiler	93°C
Range of temperature measurement	0°C÷100°C
Precision of temperature measurement	1°C
Range of temperature setting	40÷90°C
Switch-off temperature of the controller	35°C
Dimensions (w. x h. x l.)	110x70x40

Microprocessor temperature controller RT-04 „ADAŚ” is a device to operate the c.h. solid fuel boiler in the domain of stabilizing the boiler operation based on water measurement. The controller controls the c.h. system with the solid fuel boiler, in which by variably controlling the efficiency of the blower the boiler temperature changes. Additionally the operation of the c.h. circulating pump is controlled.

The controller RT-04B is equipped with an extra protection of the boiler against overheating (low-voltage sensor STB). The additional safety sensor STB is placed in one sleeve along with the main temperature sensor of the boiler.

Basic functions of the controller RT-04B:

- Temperature sensor of the c.h. boiler with an integrated safety thermostat STB.
- Acoustic and visual information of any alarm situation
- Storing any alarm situation in memory even after switching off the power.
- During any alarm the controller decreases the boiler temperature by switching off the blower and switching on the c.h. circulating pump
- Rundowns of the pumps beyond the heating season once a week for 1min
- Protection of the system against getting frozen, alarm switch-on of the pump at a boiler temperature drop below 5°C.
- Operation of the air blower with its efficiency regulation
- Operation of the circulating pump
- Realization of cyclic scavenges of the boiler (as of the ZAGAZ software version for a boiler that gases the wood - this function is disabled)
- Algorithm PID - optimization of the combustion process
- Digital display of operation parameters
- High load capacity of the output contacts
- Wide setting ranges of operation of all the devices (modulation of the blower, times and pauses of scavenges, temperature ranges of the pumps and valve)
- Stand-alone casing with sockets enabling a fast mounting and dismounting on any model of the boiler.
- Terminal for connecting an external alarm module (option)

APPLICATION

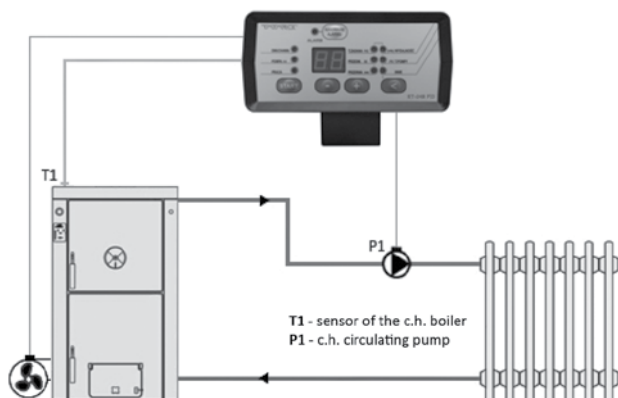

Basic technical parameters:

Power	230V / 50Hz
Power consumption (no load)	5W
Maximum connection power	580VA
Ambient temperature	0°C÷40°C
Load capacity of the blower output	1,5A/230V/50Hz (200W max)
Load capacity of the circulating pump output	1A/230V/50Hz (200W max)
Temperature measurement range	0°C÷100°C
Temperature measurement precision	1°C
Boiler temperature limit	93°C
Switch-on temperature of the safety thermostat STB	94°C
Range of the preset temperature	40÷90°C
Blower efficiency	10%÷100%
Scavenge time	1÷30s
Scavenge pause	2÷10 min
Switch-off temperature of the controller	35°C
Switch-on temperature of the circulating pump	30÷50°C
Dimensions (w. x h. x l.)	155x75x150

Basic functions of the controller:

- Algorithm PID - realization of the most effective process of combustion in the c.h. boiler
- Prevention of the c.h. system from damage and overheating STB
- Increase in comfort and economy of using the c.h. system with the use of the c.h. solid fuel boiler
- Protection of the circulating pump against jamming beyond the heating season (AntiSTOP)

RT-01 B ANIA

Microprocessor temperature controller of the central heating solid fuel boiler

Microprocessor temperature controller RT-01 B ANIA is a device to operate the c.h. solid fuel boiler in the domain of stabilizing the boiler operation based on the measurement of water temperature. The controller regulates the air blower, circulating pump, loading pump WAW (WAW - Warm Process Water), and protects the c.h. system against water boiling

Basic functions of the controller RT-04B:

- Operation of the blower (2 op modes: variable rotation or ON/OFF mode)
- Realization of temporal scavenges of the boiler
- Operation of the circulating pump CH (CH-central heating)
- Operation of the loading pump WAW with the WAW priority
- Algorithm PID - optimization of the combustion process
- Temperature sensor of the boiler CH with the integrated safety thermostat STB
- Temperature sensor of the WAW container or the buffer
- During any alarm the controller decreases the boiler temperature by switching off the blower and switching on the c.h. circulating pump CH
- Rundowns of the pumps beyond the heating season once a week for 1min
- Protection of the system against getting frozen, alarm switch-on of the pump at a boiler temperature drop below 5°C.
- You can connect any room thermostat
- Alarm indication: sound and visual
- Realization of cyclic scavenges of the pump beyond the heating season to protect the rotor against locking
- Memory of recently applied settings after power supply decline and their restoration ability
- 2 digital displays (1st- measurement screen, 2nd- settings screen)
- High load capacity of the output contacts
- Wide setting ranges of operation of all the devices (modulation of the blower, times and pauses of scavenges, temperature ranges of the pumps and valves)
- Stand-alone casing with sockets enabling a fast mounting and dismantling on any model of the boiler.
- **The controller can cooperate with a temperature sensor of the flue gas and with the pyrolysis boiler.**

APPLICATION

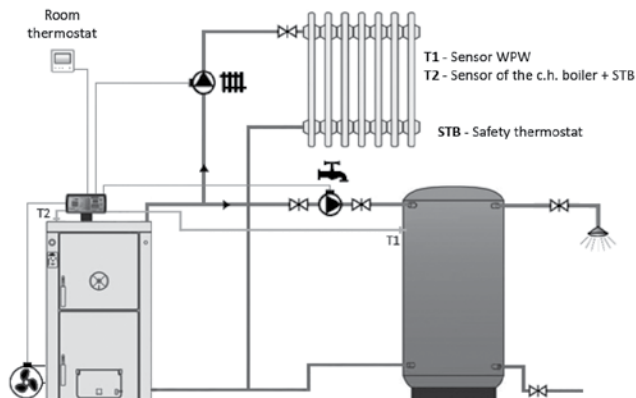

Basic technical parameters:

Power	230V / 50Hz
Power consumption (no load)	10W
Maximum connection power	800VA
Ambient temperature	0°C÷40°C
Load capacity of the blower output	1,5A/230V/50Hz (250VA max)
Load capacity of the circulating pump output	1A/230V/50Hz (150VA max)
Load capacity of the output of the loading pump WAW	1A/230V/50Hz (150VA max)
Temperature measurement range	0°C÷100°C
Temperature measurement precision	1°C
Electronic limit temperature of the boiler	93°C
Switch-on temperature of the safety thermostat STB	94°C
Range of the preset temperature	40°C÷90°C
Blower efficiency	10%÷100%
Scavenge time	1÷30s
Scavenge pause	2÷10 min
Switch-off temperature of the controller	35°C
Dimensions (w . x h . x l .)	155x75x150

Basic functions of the controller:

- Algorithm PID - Realization of the most effective process of combustion in the c.h. boiler
- Double protection of the c.h. system against damage and overheating (sensor STB)
- Protection of the circulating pump against jamming beyond the heating season (AntiStop)
- Operation of the loading pump WAW and WAW container (WAW priority) . WAW - Warm Process Water.
- Connecting a room thermostat is possible
- Maximum connection power 800 W !

Microprocessor temperature controller RT-02 B ANETA is a device to operate the c.h. solid fuel boiler in the domain of stabilizing the boiler operation based on the measurement of water temperature. The controller regulates the air blower, circulating pump, loading pump WAW (WAW - Warm Process Water), and protects the c.h. system against water boiling

Basic functions of the controller RT-04B:

- Operation of the blower (2 op modes: variable rotation or ON/OFF mode)
- Realization of temporal scavenges of the boiler
- Operation of the circulating pump CH (CH-central heating)
- Operation of the loading pump WAW with the WAW priority
- Integrated time zone thermostat enabling a time-based control of the boiler within a selected time zone of the day
- Algorithm PID - optimization of the combustion process
- Temperature sensor of the boiler CH with the integrated safety thermostat STB
- Temperature sensor of the WAW container or the buffer
- During any alarm the controller decreases the boiler temperature by switching off the blower and switching on the c.h. circulating pump CH
- Rundowns of the pumps to protect the rotor against locking beyond the heating season once a week for 1min
- Protection of the system against getting frozen, alarm switch-on of the pump at a boiler temperature drop below 5°C.
- You can connect any room thermostat
- Alarm indication: sound and visual
- Memory of recently applied settings after power supply decline and their restoration ability
- 2 digital displays (1st- measurement screen, 2nd- settings screen)
- High load capacity of the output contacts
- Wide setting ranges of operation of all the devices (modulation of the blower, times and pauses of scavenges, temperature ranges of the pumps and valves)
- Stand-alone casing enabling a fast mounting and dismounting on any model of the boiler.
- You can connect up an external alarm module (option)



Basic technical parameters:

Power	230V / 50Hz
Power consumption (no load)	10W
Maximum connection power	1260VA
Ambient temperature	0°C ÷ 40°C
Load capacity of the blower output	3,5A/230V/50Hz (800VA max)
Load capacity of the circulating pump output	1A/230V/50Hz (230VA max)
Load capacity of the output of the loading pump WAW	1A/230V/50Hz (230VA max)
Temperature measurement range	0°C ÷ 100°C
Number of time zones	4
Number of operation modes of the blower	3
Temperature measurement precision	1°C
Electronic limit temperature of the boiler	93°C
Switch-on temperature of the safety thermostat STB	94°C
Range of the preset temperature	40÷90°C
Blower efficiency	10%÷100%
Scavenge time	1÷30s
Scavenge pause	2÷10 min
Switch-off temperature of the controller	35°C

Output with the nonvoltage relay to compatible room thermostat

Basic functions of the controller:

- The controller is equipped with the clock enabling an automatic change of the boiler temperature in 4 selectable times of the day.
- Double protection of the c.h. system against overheating and the damage (sensor STB)
- Protection of the circulating pump against jamming beyond the heating season (AntiStop)
- Operation of the loading pump WAW and WAW container. The WAW priority. (WAW - Warm Process Water)
- Connecting a room thermostat is possible
- Maximum connection power 1260 W !

APPLICATION

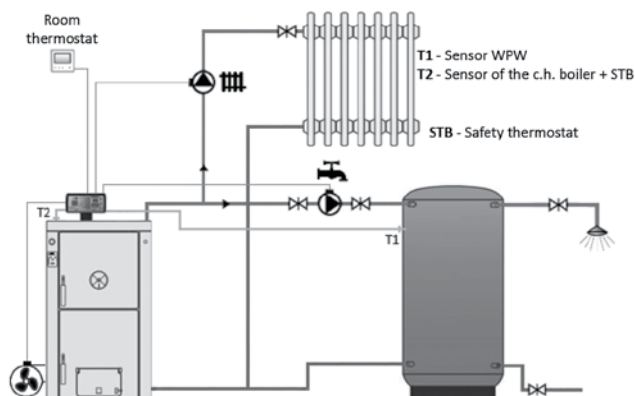

RT-02 B ANETA microprocessor temperature controller of the central heating solid fuel boiler

RT-09 RETORTA PID

Microprocessor temperature controller of the central heating boiler with the feeder

■ The controller RT-09 PID Tatarek is a high quality device with the PID algorithm, LCD display and capability to connect up a room panel of any producer. It also has the output for connecting a TATAREK home panel SP1, which shows up the boiler operation and features the time zones that control air temperature of the room. The PID denotes another version of the controller, in which an influence of the regulation error (the proportional part), its history, that is, the integral part) and the change rate (the derivative part) are taken into account. That's the source of the name PID. For the heating boiler the best results are theoretically achieved if the combustion is carried out in the continuous way, at such a selection of the air-fuel mixture at which a full combustion is reached. Therefore the controller has to give a variable control of the power and adjust the power to the actual needs of the heating system. By analyzing the tendencies of the temperature changes the controller RT-09 PID modifies its settings aiming for the so-called equilibrium point.

■ The controller controls the central heating system CH and WAW (Warm Process Water) with the boiler equipped with the worm or drawer feeder of the fuel, in which by altering the cycle of the fuel feeding the boiler temperature changes. The enhanced algorithm of the operation PID enables the operation with an automatic modulation of the boiler power, such an amount of heat is generated, for which the need arises, thanks to that the combustion process is smooth (There're no sudden changes of temperature in the combustion chamber and chimney), more efficient and guaranteeing a longer life of the heating system.

- **RT-09 PID controls** the operation of blower, circulating pump CH and loading pump WAW (warm process water)
- **RT-09 PID is equipped with** the clock, which enables an automatic change of the settings at a different time of the day.
- **RT-09 PID can** cooperate with any room thermostat or a remote controlled device of the TATAREK company.
- **RT-09 PID itself chooses** the fuel dose. Though the blower power has to be manually selected which corresponds to a coal quality for the moment of the fuel feeding and for the operation without the fuel feeding.

■ If you connect a room thermostat of any kind that is equipped with the nonvoltage relay output the rules of operation are as follows: After the preset temperature of the room is reached the thermostat decreases the preset temperature of the boiler to the value of the parameter 14, in service 50°C (programmable temperature in the range of 25-85OC with the reservation that the parameter is to be higher than the switch-off temperature of the controller). The cyclic operation of the pump CH is initiated (programmable parameter 41). The default is 30s (operation time is constant) , the pause is 4min (pause range 1-30min).

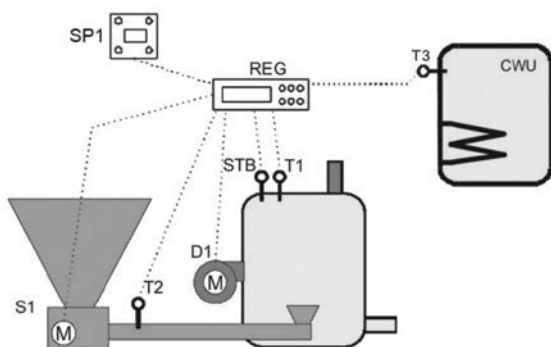

■ The controller has 4 levels of operation, which considerably helps the people who don't have much knowledge about dealing with electronic devices.

Level 0, no parameter is available.

Level 1, the most commonly used parameters are enabled:

- Switch-on time of the feeder in the operation and pause cycle
- Switch-off temperature of the pump WAW
- Priority WAW, range OFF./ON./SUMMER. The SUMMER mode is the same operation of the loading pump WAW.

Level 2, parameters connected with the settings of the time zones. The time zones are 4, the zone 0 or so-called base zone is the basic setting of the boiler.

Level 3 requires the activation of the configuration parameters. Entering this level requires a deep read of the user manual. It enables an exact adjustment of the controller to the system.

Basic technical parameters:

Power	230V/50Hz
Power consumption without load	10W
Maximum connection power	1400W
Operation conditions	0÷55°C, humidity 10÷80% no condensation
Housing protection class	IP30
Control output to the feeder	3A / 230VAC
Control output to the blower	1A / 230VAC variable regulation of rotations
Control output to the circulating pump CH	1A / 230VAC
Control output to the loading pump WAW	1A / 230VAC
Safety thermostat of the boiler	bimetallic 95°C
Safety thermostat of the feeder	bimetallic 90°C
Temperature sensor of the boiler	KTY81 (0...+100°C)
Temperature sensor of the container WAW	KTY81 (0...+100°C)
Temperature measurement precision	2°C
Temperature measurement resolution	0,5°C
Number of time zones	4

■ TSP-100 is an energy-saving and reliable controller of the c.h. pump, which manually or automatically turns on/off the circulating pump according to the preset temperature.

■ The controller allows to operate the devices of maximum connection power up to 600W. The whole control takes place based on the temperature measurement of water in the range of 25°C - 85°C. It's got 2 modes of operation, which are chosen on the control panel with the MANUAL/AUTO switch.

■ The first operation mode is the automatic one (AUTO) that allows to automatically turn on/off the pump after exceeding the temperature set by the user. The selection of the temperature takes place with the handle placed at the center of the control panel that has the temperature scale. Turning on and operation of the pump in the automatic mode is indicated by the light-emitting diode described as AUTO on the control panel. This same way is also indicated the manual operation of the pump. Here the diode described as MANUAL lights up.

The mode MANUAL is the second mode of operation that can be realized by this controller. After going over to that mode chosen with the MANUAL/AUTO switch it's possible to manually turn on/off the pump at any moment the user wants.



Basic functions of the controller:

- Operation of the c.h. pump in the AUTO mode based on the user's preset temperature
- Capability to operate in the MANUAL mode, where the continuous operation of the pump is realized. It ensures an emergency operation of the pump in case the temperature sensor is damaged or failure of activating the AUTO mode.
- Energy-saving and reliable operation

■ On special order the controller can have the reverse parameters of the pump operation, due to this enabling the operation of the loading pump WAW (switch-on of the pump at the temperature drop below the preset setting). The code of the controller is TSP-200.

APPLICATION

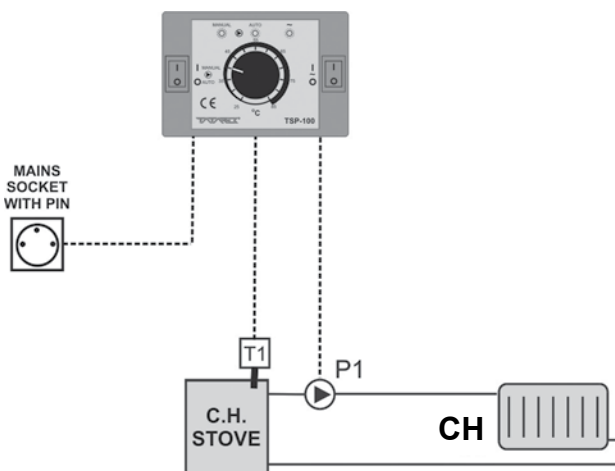

T1 - sensor KTY 81-210 encased
 CH - central heating
 P1 - c.h. circulating pump

Basic technical parameters:

Power	230V / 50Hz
Power consumption without load	1W
Maximum connection power	600W
Operation conditions	0°C÷40°C
Number of outputs to control the circulating pump (valve)	1* 500W/230V/50Hz
Number of temperature sensors	1
Setting range of temperature	25°C÷85°C
Precision of temperature setting	2°C
Resolution of temperature setting	5°C
Heat resistance of the sensor	-25°C±100°C
Time delay fuse	2,5A/250V
Housing protection class	IP40
Dimensions (w. x h. x l.) [mm]	110 x 70 x 40

RT-08 SOLAR

Microprocessor temperature controller of the heating system equipped with the solar collector and water jacket stove

■ **Microprocessor temperature controller RT-08 solar** is a family of devices to operate the heating systems, in which the heat sources are: solar collectors in different configurations and the heat receivers are: Warm Process Water container (WAW), buffer container and central heating (CH).

RT-08 SOLAR is available in different software versions:

■ **RT-08TL** - Controller controls the heating system, in which the heat source is a solar collector and the heat receiver is a buffer. The solar collector pump runs with a variable regulation of rotations, which enables to optimally make use of the collector heat.

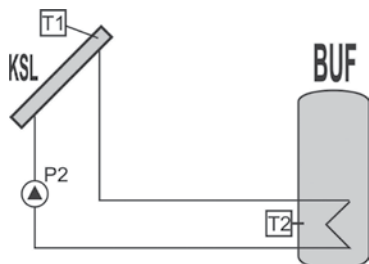

■ **RT-08TH** - Controller controls the heating system, in which the heat source is a solar collector and the heat receiver is a buffer. The solar collector pump runs with a variable regulation of rotations, which enables to optimally make use of the collector heat. The controller is equipped with the clock, which at the selected times of the day turns on the circulation pump of the process water and alternative heat source (e.g. electric heater, gas boiler and the like)

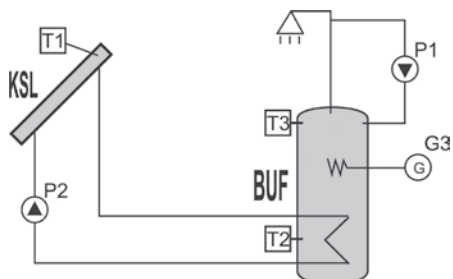

■ **RT-08T** - Controller controls the heating system, in which the heat sources are: solar collector and water jacket stove. The heat receivers are: Warm Process Water container (WAW) and Central Heating system (CH). The solar collector pump runs with a variable regulation of rotations, which enables to optimally make use of the collector heat.

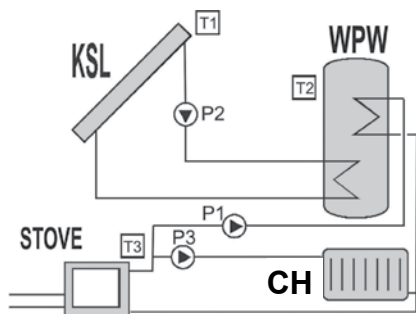

- KSL- Solar collector
- WPW- Warm Process Water container (boiler)
- CH- Central heating

- T1- Temperature sensor of the solar collector
- T2- Temperature sensor of the container WPW
- T3- Temperature sensor of the water jacket

- P1- Loading pump of the container WPW from the stove
- P2- Loading pump of the container WPW from the solar collector
- P3- Central heating circulating pump



■ RT-08 SOLAR TITANIUM DESIGN



■ RT-08 SOLAR STANDARD

Basic technical parameters:

Power	230V / 50Hz
Power consumption without load	5W
Maximum connection power	750W
Number of outputs to control the solar pump	1 *1A / 230V / 50Hz variable regulation of rotations
Number of temperature sensors of the solar collector	1 *KTY84 (0...+200°C)
Temperature measurement precision	2°C
Temperature measurement resolution	0,5°C
Number of time zones	4
Fuse	6,3A / 250V
Housing protection class	IP41
Operation conditions	0÷50°C, humidity 10÷90% no condensation

■ **RT-08 DUO** - Controller controls the heating system, in which the heat sources are 2 solar collectors. The heat receiver is the Warm Process Water container (WAW)

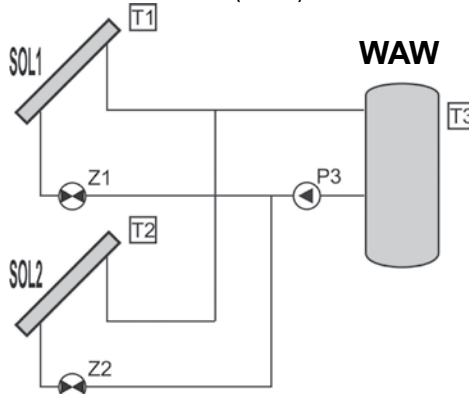

Temperature controller of the mixing valve and circulating pump

RT-12 MIXER

■ TEMPERATURE CONTROLLER OF THE MIXING VALVE RT-12 is suited for a variable regulation of the servo of the 3-way valve in order to maintain the user-defined temperature at its output. The controller can operate any mixing valve equipped with the drive motor of the valve supplied with 230V AC.

■ Advantage of applying the RT-12 controller is a protection of the heat receivers connected behind the mixing valve against too high temperature. It also helps maintain a constant temperature at the level set by the user to ensure a correct minimum temperature of the device operation. It's mainly important for such devices like boilers of the central heating where the protection of water returning to the boiler from the heating system allows to more economically make use of them. That also considerably extends the life of the boiler.

■ The control functions are realized by the 2 outputs that are responsible for controlling the valve drive and one extra output that enables to operate the circulating pump. To increase the comfort and safety of the system operation the controller additionally has 2 outputs for connecting the room thermostat and thermostat which protects the system against overheating.

■ All the alarm situations are indicated with sound and blinking alarm LED on the control panel

■ The controller features a small compact casing and easy mounting. The basic version of the RT12 controller is to be mounted subplaster in the conventional double electric box. The other version is an overplaster one.



■ RT-12 subplaster



■ RT-12 overplaster

Basic technical parameters:

Power	230V / 50Hz
Power consumption without load	2W
Maximum connection power	600W
Number of outputs to control the valve drive	2* 200W/230V/50Hz
Number of outputs to control the circulating pump	1* 200W/230V/50Hz
Number of temperature sensors	1
Setting range of temperature	30°C÷90°C
Temperature measurement precision	+/- 2°C
Temperature measurement resolution	1°C
Output of the room thermostat	1* 2mA/5V
Output of the alarm thermostat	1* 2mA/5V
Fuse	2,5A/250V zwłoczny
Housing protection class	IP41
Dimensions (w. x h. x l.) [mm]	110 x 70 x 40

Basic functions of the controller:

- Maintaining the user's setting of the constant water temperature of the heating system behind the mixing valve
- Protecting the central heating system against overheating and guaranteeing a safe operation of cooperating devices, which are connected behind the output of the mixing valve
- Increasing the comfort and safety of using the c.h. system due to cooperating with the room and alarm thermostat.

APPLICATION

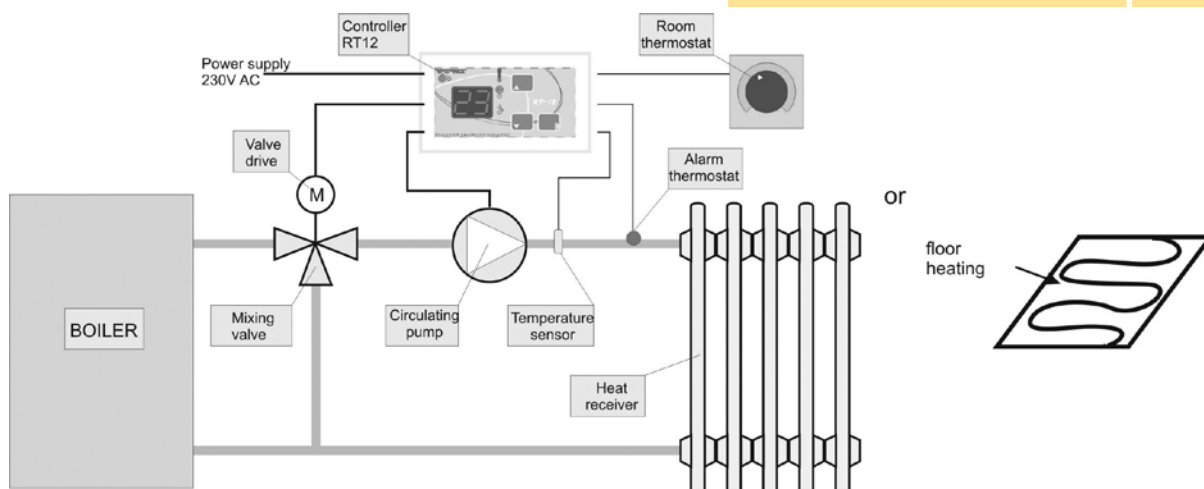

A200 WAC

**Emergency power supply of the heating systems:
c.h. stoves, water jacket stoves,
solar systems, pumps**

■ **The emergency power supply A 200 WAC TATAREK** supports devices in case of the mains voltage decline. It ensures the operation of devices supplied by AC current signal of 230V and total power not going over 200W. It works with the traction battery and capacity-dependently guarantees a long time substitute of the power supply source. In case the mains is down the A200WAC power supply also enables to operate any kind of gas or oil boiler, which has got an electronic regulation of the boiler operation.

■ **A200WAC TATAREK** is especially designed to cooperate with heating systems (heating automatics, circulating pumps, blowers, electrovalves, and the like). It can supply other devices that are not affected by temporary voltage declines (e.g.: fax, telephone exchange and the other telecommunication equipment).

■ The voltage decline of the mains automatically switches the power supply to the emergency mode. It draws current from the battery and supplies the connected devices. The voltage conversion is made by the built-in converter DC/AC. After the voltage comes back to the mains, the A 200 WAC automatically gets back to the standby mode charging the battery up to its maximum capacity. The power supply is equipped with a signalling of the battery voltage decline, protection of the battery's over-discharge as well as a system of keeping the battery in the standby mode.

■ **Which battery to choose ?** For the A200WAC power supply we recommend **new batteries that are designed to operate based on the buffer (e.g. AGM or gel battery)** of the minimum capacity 45Ah and the maximum one 120Ah, whose projected life is 5-12 years.

■ **Please be careful, because the A 200WAC is not UPS and not designed to be used for devices whose continuous operation is crucial (e.g. servers, medical appliances and the like).**

■ **The A200WAC is especially handy in places where the voltage often declines !** The user exempts from a lot of nerves. The power supply ensures the comfort and safety of the heating system at home or in an apartment.

APPLICATION

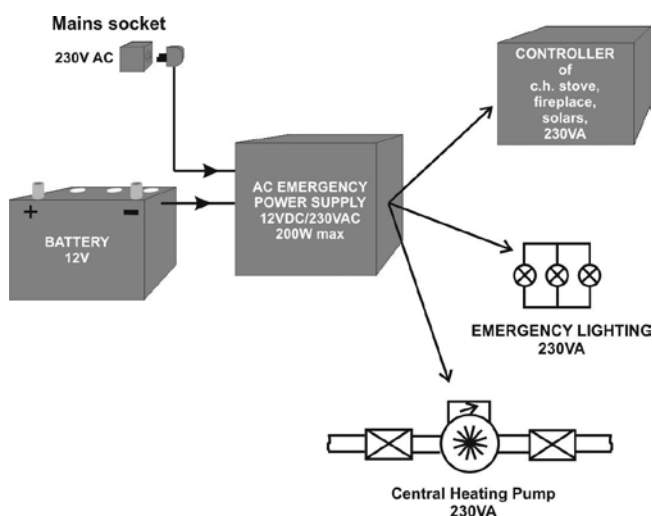

Approximate operation time of the A200WAC at the maximum load

Battery 12V	45Ah	65Ah	80Ah	120Ah
Operation time	~2h	~3,5h	~4,5h	~6,5h



■ A200WAC



Basic technical parameters

Power supply	~230VAC ± 10% 50Hz/1A/230VA
Battery voltage	12V (10,5÷15V)
Output voltage (mains operation)	~230VAC ± 10% 50Hz
Output voltage (battery operation)	~230VAC ± 10% 50Hz ± 2%
Maximum load power	200W
Maximum battery current (battery operation)	19A
Switching time to the battery operation	approx. 1s
Switching time to the mains operation	approx. 5s
Working temperature range	0÷40°C
Insulation class	class 1
Inflammability class	UL94-V1
Housing protection class	IP30

Output voltage waveform

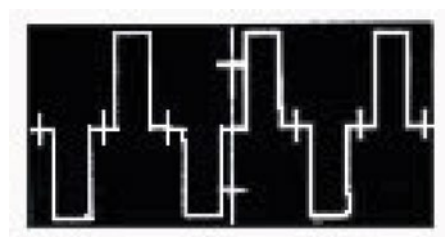

The power supply A 200 WAC generates the so-called approximate-sine voltage signal. That's why you need to make sure if the supplied device can be connected to such a power supply source !

Emergency power supply of the heating systems: c.h. stoves, water jacket stoves, solar systems, pumps

A600WAC

■ **The emergency power supply A 600 WAC TATAREK** supports devices in case of the mains voltage decline. It ensures the operation of devices supplied by AC current signal of 230V and total power not going over 600W. It works with the traction battery and capacity-dependently guarantees a long time substitute of the power supply source. In case the mains is down the A600WAC power supply also enables to operate any kind of gas or oil boiler, which has got an electronic regulation of the boiler operation.

■ **A600WAC TATAREK** is especially designed to cooperate with heating systems (heating automatics, circulating pumps, blowers, electrovalves, and the like). It can supply other devices that are not affected by temporary voltage declines (e.g.: fax, telephone exchange and the other telecommunication equipment).

■ The voltage decline of the mains automatically switches the power supply to the emergency mode. It draws current from the battery and supplies the connected devices. The voltage conversion is made by the built-in converter DC/AC. After the voltage comes back to the mains, the A 600 WAC automatically gets back to the standby mode charging the battery up to its maximum capacity. The power supply is equipped with a signalling of the battery voltage decline, protection of the battery's over-discharge as well as a system of keeping the battery in the standby mode.

■ **Which battery to choose ?** For the A600WAC power supply we recommend **new batteries that are designed to operate based on the buffer (e.g. AGM or gel battery)** of the minimum capacity 45Ah and the maximum one 120Ah, whose projected life is 5-12 years.

■ **Please be careful, because the A 600WAC is not UPS and not designed to be used for devices whose continuous operation is crucial (e.g. servers, medical appliances and the like).**

■ **The A600WAC is especially handy in places where the voltage often declines !** The user exempts from a lot of nerves. The power supply ensures the comfort and safety of the heating system at home or in an apartment.



■ **A600WAC**



Basic technical parameters

Power supply	~230VAC ± 10% 50Hz/1A/230VA
Battery voltage	12V (10,5÷15V)
Output voltage (mains operation)	~230VAC ± 10% 50Hz
Output voltage (battery operation)	~230VAC ± 10% 50Hz ± 2%
Maximum load power	600W
Maximum battery current (battery operation)	19A
Switching time to the battery operation	ok. 1s
Switching time to the mains operation	ok. 1s
Working temperature range	0÷40°C
Insulation class	class 1
Inflammability class	UL94-V1
Housing protection class	IP30

Output voltage waveform

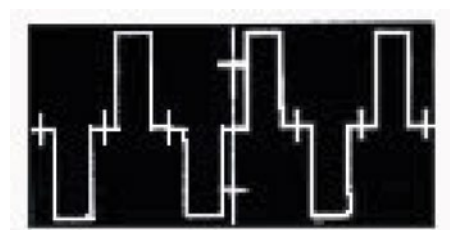

The power supply A 600 WAC generates the so-called approximate-sine voltage signal. That's why you need to make sure if the supplied device can be connected to such a power supply source !

APPLICATION

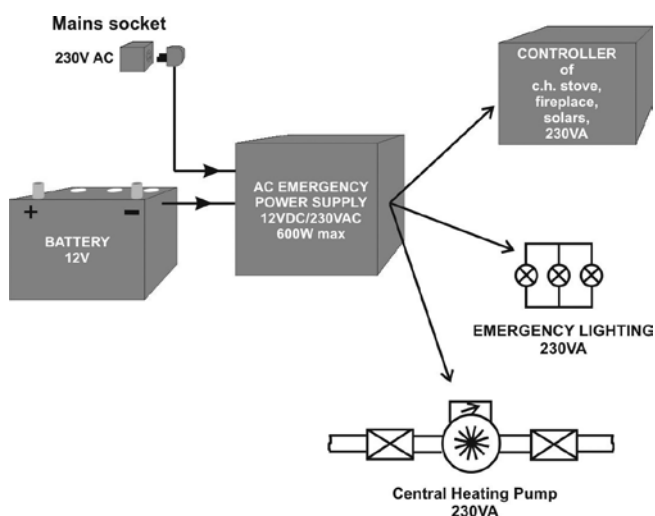

RT-16

Controller of the heating system equipped with the solid fuel boiler

■ The controller RT-16 TATAREK is the latest and most advanced device of the TATAREK company. It is designed for controlling both the solid fuel boilers with the automatic fuel feeder and the heating system supplied by the boiler. Thanks to the applied algorithm PID you can variably control the power modulation of the boiler depending on heat requirement in the system and then the whole process performs very smoothly, which contributes to a very efficient operation of the boiler and its longer life.

The controller has got a module-based design of the executive part, which allows it to be extended with any element depending on the type and structure of the boiler and the heating system supplied by the boiler.

In this model a new, modern solution has been applied in terms of protecting the furnace in case of the power supply decline and connected with that a risk of pushing back a flame through the fuel feeder to the feeding chamber. This solution is called Anti Fire System (AFS) and is applicable to all boiler types that are ready for connecting the air damper directly with the combustion chamber of the boiler. In case of the voltage collapse the air damper is being opened, delivering the so-called "leak" air that causes a safe burning out of the last portion of the fuel that was fed onto the retort before the collapse. That kind of solution gives a full protection of the feeder against a flame withdrawing and by that it meets the safety requirements included in the European Union standards that are related to the protection of heating systems.

■ The controller is capable of connecting the following sensors:

- Flue gas temperature sensor (thermocouple)
- Sensor of the delivery temperature of the boiler
- Sensor of the return temperature of the boiler
- Temperature sensor of the feeder
- Temperature sensor of the central heating CH (behind the mixing valve in the circuit 1)
- Temperature sensor of the central heating CH (behind the mixing valve in the circuit 2)
- Sensor of ambient temperature
- Temperature sensor of the circuit WAW
- Sensor STB (Safety thermostat)

■ The devices operating the operation of the boiler:

- Fan (250W max)
- Feeder drive (300W max)
- Heater of firing up the fuel (450W max)

■ The devices operating the operation of the heating system:

- Pump CH of the circuit 1 (150W max)
- Pump CH of the circuit 2 (150W max)
- Pump WAW (150W max)
- Drive of the mixing valve of the circuit 1 (150W max)
- Drive of the mixing valve of the circuit 2 (150W max)
- Room thermostat of the circuit 1
- Room thermostat of the circuit 2

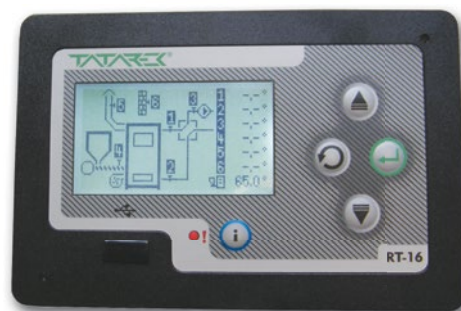

■ The controller is equipped with the USB port that allows for upgrading the software and as an option peaking into the history of the installations over the defined time.

The given description of the controller relates to its standard equipment. Its module-based construction allows for extending its functionality from the point of view of individual requirements of the manufacturer.

Basic technical parameters

Power	230V/50Hz
Power consumption without load	10W
Maximum connection power	1400W
Operating conditions	5÷50 °C, humidity 10÷80% no condensation
Output for controlling the feeder	300W/230VAC
Output for controlling the fan	250W/230VAC variable control of rotations
Output for controlling the pumps	150W/230VAC
Output for controlling the heater of the biomass	450W/230VAC
Fuse	6,3A/250V
Temperature sensors of the boiler	NTC 2.2k
Temperature measurement precision	2 °C
Temperature measurement resolution	0,1 °C