

## OTHER SYSTEMS OF THE TRIO FAMILY



### TRIO SESSION

Subwoofer 12" - 320 mm - VC 65 mm  
Satellites 2 x 8" - 200 mm - VC 50 mm  
Horn Compression Tweeter - VC 34 mm  
Power Max/RMS: 1280 / 640 W  
SPL Max: 124 dB



### TRIO MASTER

Subwoofer 15" - 380 mm - VC 75 mm  
Satellites 2 x 10" - 250 mm - VC 50 mm  
Horn Compression Tweeter - VC 44 mm  
Power Max/RMS: 1440 / 720 W  
SPL Max: 127 dB



Full Range Sound System

## TRIO CLUB

User Manual



PROFESSIONAL SPEAKERS, AMPLIFIERS AND ACCESSORIES

Audiodesign Srl  
Via dell'industria, 28 - 42025 CAVRIAGO (RE)  
+39 0522 941444 - Fax +39 0522 942363  
www.audiodesign-pro.com  
info@audiodesign.it

### Introduction

Thank you for purchasing an AudioDesign TRIO Active Sound system. TRIO series is designed to provide an high and powerful sound quality in a compact size.

The main features are:

- Active subwoofer cabinet with additional amplifiers for the passive satellites.
- High sensitivity passive satellites.
- High and precise acoustic quality also with high power.
- Portability: the system is easy fit and portable by one person.

The final result is a full, detailed and powerful sound.

### Application

The TRIO systems are a professional solution for every DJ or Live events where high pressure and extreme sound quality is required.

### Precautions:

Caution: When using any electric product , precautions should always be taken, including the following:

- 1) Read carefully all instructions before using the product.
- 2) To reduce the risk, strict supervision is necessary when the product is used near children.
- 3) Don't use the product near to water sources like sinks, kitchens, wet floors, pools, or similar or when raining.
- 4) In case hearing losses or buzzing occur, please contact a doctor.
- 5) This products should be located so that its position does not interfere or reduce its proper ventilation.
- 6) This product should be site away from heat sources such as radiators or any other product that generate heat.
- 7) This product should be connected to a power supply line only of the type described on the operating instructions. Check always the status of the power cable.
- 8) In case you need to replace the fuse, unplug power supply before replacement. The fuse is located over the power socket and needs to be replaced with a fuse of same type and value. If the fuse blows again, please contact our service. DON'T replace it a second time with a higher value fuse.
- 9) Unplug power supply when left unused for a long period of time. Don't draw the cable but pull out the plug.
- 10) Make sure that power switch can always be easily reached.
- 11) The product needs to be inspected by authorized or qualified personnel in case:
  - A- The power cable or plug are damaged
  - B- Objects or liquids fall inside the product
  - C- The product has been exposed to rain
  - D- The product doesn't appear to operate normally or exhibits a marked change in performance.
  - E- The product has fallen and been damaged.
- 12) DON'T operate on the product, except indications on the user's manual . Please refer to authorized and qualified personnel for any other operation.
- 13) Caution: Don't place objects on the product's power cable or place it in a position where it could be damaged or cause interferences. Improper installation could cause fire risk and/or personal injury.

### Service

All Audio Design PRO products have been inspected and tested before leaving the factory and , if properly used, they will work for many years. However, in case of any problem, please proceed in the following way:

Contact your dealer and inform about the defect you found

In case it won't be possible to solve the problem with the dealer, the product needs to be returned, preferably in its original packaging or in a proper packing to protect it during the transport. Purchase documents must be produced too.

Your dealer will arrange the shipment to our service centre.

### Conformity:

Audiodesign Pro products comply with presently existing directives and standards.

### TECHNICAL SPECIFICATIONS

SUBWOOFER STAGE PRO W10	
INPUT	LINE IN: Combo Socket XLR 3-F / Jack Stereo INPUT: Balanced and Unbalanced
OUTPUT	SATELLITES OUTPUT: Speakon NL4 (pin 1+ = +, pin 1- = -)
AMPLIFIERS	Subwoofer Power Output: 250 W RMS (500 W Max) Satellites Power Output: 2x125 W RMS (2x250 W Max) @ 4 Ohm Load
SPEAKER	Electronic Crossover LP Subwoofer: Frequency 46 - 240 Hz / 12 dB/Oct.
	Electronic Crossover HP Satellites: Frequency 38 - 250 Hz / 12 dB/Oct.
	Subwoofer: 1 x 10" (250 mm) VC 50 mm
	Frequency Response: 30 + 260 Hz (± 3 dB)
	SPL Max: 121 dB
WEIGHT & SIZES	Weight Subwoofer: 32 kg Sizes (WxLxH) cm: 43 x 39 x 39

SATELLITE STAGE PRO 65	
INPUT	SATELLITES INPUT: Speakon NL4 (pin 1+ = +, pin 1- = -)
SPEAKERS	High Sensitivity Woofer 1 x 6.5" (165 mm) VC 32 mm Dome Tweeter VC 30 mm
MAIN FEATURES	TOTAL IMPEDANCE : 4 Ohm TOTAL POWER : 160 W RMS (250 W Max) with X-over 200 Hz 18 dB/oct TOTAL SPL Max: 121 dB Frequency Response: 100 + 20000 Hz (± 3 dB) Tweeter Crossover: 6000 Hz 12 dB/oct Passive
WEIGHT & SIZES	Weight Satellite: 4 kg Size (WxLxH) cm: 20 x 19 x 27

BY MEANS OF OUR ACCESSORIES, DIFFERENT CONFIGURATIONS OF THE SYSTEM ARE POSSIBLE



Volume setting of the system is made by means of the three LEVEL knobs on top of the subwoofer:

- Left satellite is GAIN LEFT **6**
- Right satellite is GAIN RIGHT **6**
- Subwoofer is GAIN SUBWOOFER **3**

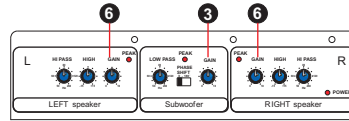

Before switching power on and proceed to system setting, make sure that all three knobs are completely turned counterclockwise, at level 0, and that the mixer output is set so that the peaks level stays about within 0 e +3 dB.

Set first the satellites volume alone and then the subwoofer volume alone.

### Satellites Volume setting

- Switch power on and begin to turn clockwise the satellite GAIN knobs **6** until the correspondent PEAK led begins to flash shortly for less than 1 second.  
This is the optimal level being connected to a mixer sending to MAIN a signal with level peaks within 0 and +3dB.
- Now listen to the satellites with this output level; if you detect distortion or saturation of the signal (i.e. of microphone) check the possibility of reducing the level of the signal concerned at his source, otherwise try to slightly lower the mixer's main output. Should this not be enough, reduce the satellites volume until you have an optimal sound. Memorize the knobs setting.

### Sub Volume setting

- After having memorized the knobs setting LEFT e RIGHT, take them back to 0 and begin now to turn clockwise the SUBWOOFER GAIN knob **3** until the correspondent PEAK led begins to flash shortly for less than 1 second.  
This is the optimal level being connected to a mixer sending to MAIN a signal with level peaks within 0 and +3dB.
- Now listen to the Sub with this output level; if you detect distortion of basses, turn slightly the knob back counterclockwise.

### Final system setting

- Bring the three knobs at the optimal level you have checked and listen to the complete system, again at the mixer main level peaks between 0 and +3 dB.  
If you detect too much basses compared with satellites output, turn slightly back the SUB LEVEL knob.  
If you detect instead not enough basses, turn slightly back the satellites LEVEL LEFT and RIGHT knobs.

As a general rule, the output level of the mixers should be set so that the sound peaks remain between 0 to +3 dB about. When the system TRIO CLUB gets in the two Line In (10 and 11) a signal with that amplitude and it is set as explained above, it grants the maximum performance in terms of maximum undistorted amplification (at clip limit) and in this conditions you get the maximum possible sound pressure (SPL).

RESPONSE DIAGRAM TRIO CLUB

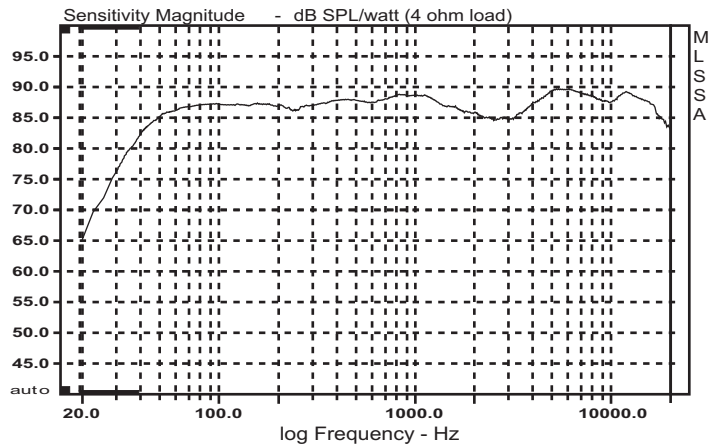

AUDIODESIGN PRO: TRIO CLUB

MLSSA: Frequency Domain

## SYSTEM COMPONENTS

This TRIO CLUB stereo system is composed by three elements: 1 Active Subwoofer **STAGE PRO W10**  
2 Passive Satellites **STAGE PRO 65**

### Active Subwoofer STAGE PRO W10



The active subwoofer STAGE PRO W10 is equipped with a 10" (250 mm) woofer with 50 mm VC.

The cabinet integrates all necessary electronics for amplification and system processing:

3 amplifiers in AB Class for a total power of 500 W RMS (1000 W Max)

1 x 250 W RMS (500 W Max) for the Subwoofer itself

2 x 125 W RMS (250 W Max) for the two passive satellites (@ 4 Ohm load)

The Subwoofer signal is LowPass filtered, adjustable from 46 to 240 Hz 12 dB/oct.

The Satellites signals are HighPass filtered, adjustable from 38 to 250 Hz 12 dB/oct.

Cabinet of high density MDF, anti-scratch embossed painting

Practical transport handles hollowed into the wood

Integral rigid metal grill

Housing hole for  $\varnothing$  35 mm stand tubes

Sizes & weight: 43 x 39 x 39 cm; 32 kg.

### Connections and Control Panels

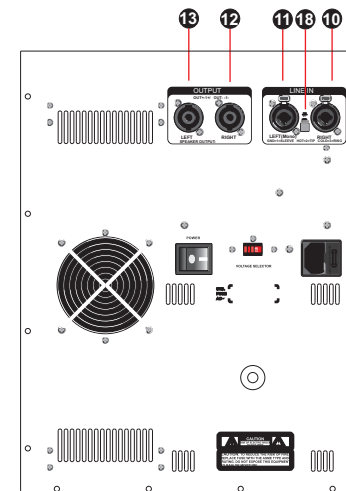
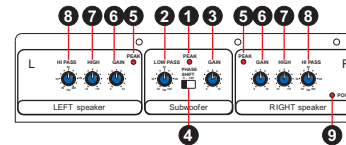

- 1 Subwoofer Clip Indicator
- 2 Subwoofer LOW PASS control adjustable from 46 to 240 Hz
- 3 Subwoofer Volume control
- 4 Phase Switch 0-180°
- 5 Satellites Clip Indicator (Separated Left and Right)
- 6 Satellites Volume control separated on channel LEFT and RIGHT. it controls only the signal going respectively to left and right satellite.
- 7 High tones equalization separated for left and right channel -15 / +15 dB
- 8 Satellites HI PASS control separated LEFT and RIGHT from 38 to 250 Hz  
**ATTENTION: the HI PASS frequency should not be set under 120 Hz**
- 9 ON LED indicator (Red)
- 10 Right Channel Line In  
Combo Socket XLR 3-F / Jack 6,3 mm Balanced
- 11 Left Channel Line In  
Combo Socket XLR 3-F / Jack 6,3 mm Balanced
- 12 Speakon Socket Right Satellite
- 13 Speakon Socket Left Satellite
- 14 Amplifier cooling fan; keep it clean for a correct ventilation.
- 15 On/Off power switch - In position 0 the system is Off
- 16 Voltage Selector
- 17 Power Net Socket
- 18 ST/MONO Switch (Stereo / Mono): se si seleziona STEREO,  
When STEREO is selected, the system sends to the Right and Left channels the correspondent Right and Left input signals.  
When MONO is selected, the system sends to both Right and Left channels only the LEFT input signal, so one complete system per channel can be used..

### High sensitivity passive satellites STAGE PRO 65



The high sensitivity passive satellite STAGE PRO 65 is a bass reflex cabinet equipped with:

One 6.5" (165 mm) woofer with a 32 mm vented voice coil

One DOME tweeter with a 30 mm voice coil

High Pass Filter at 6000 Hz 12 dB/oct on tweeter

4 ohm Impedance

Speakon socket for connection to the subwoofer amplifier

Cabinet in high density MDF , embossed anti-scratch painting

Integral protection grill

Housing hole for  $\varnothing$  35 mm stand tubes

Sizes and Weight: 20 x 19 x 27 cm; 5 kg.



### SYSTEM CONNECTION IN STEREO CONFIGURATION (ST/MONO Switch up)

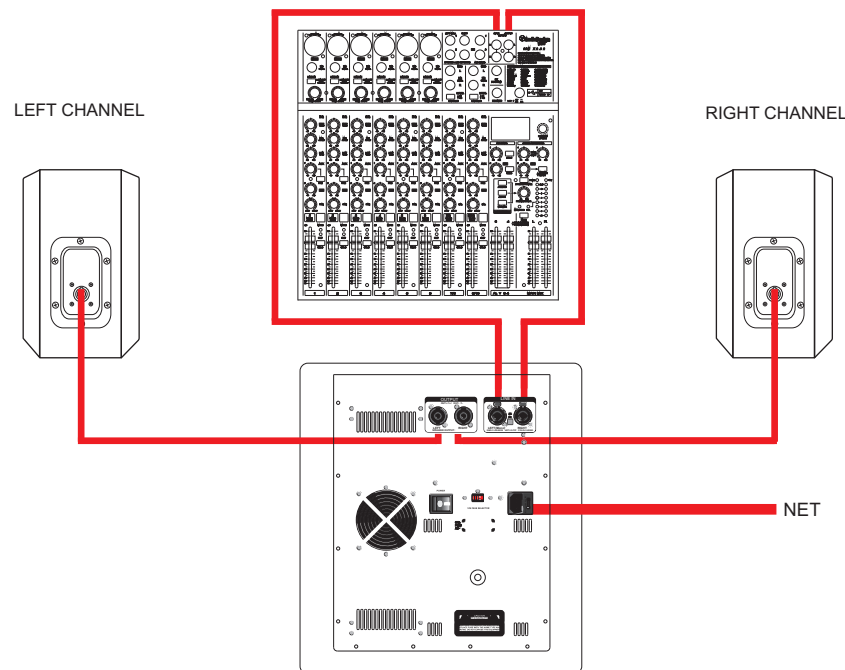

### CONNECTION OF TWO SYSTEMS IN MONO CONFIGURATION (ST/MONO Switch down)

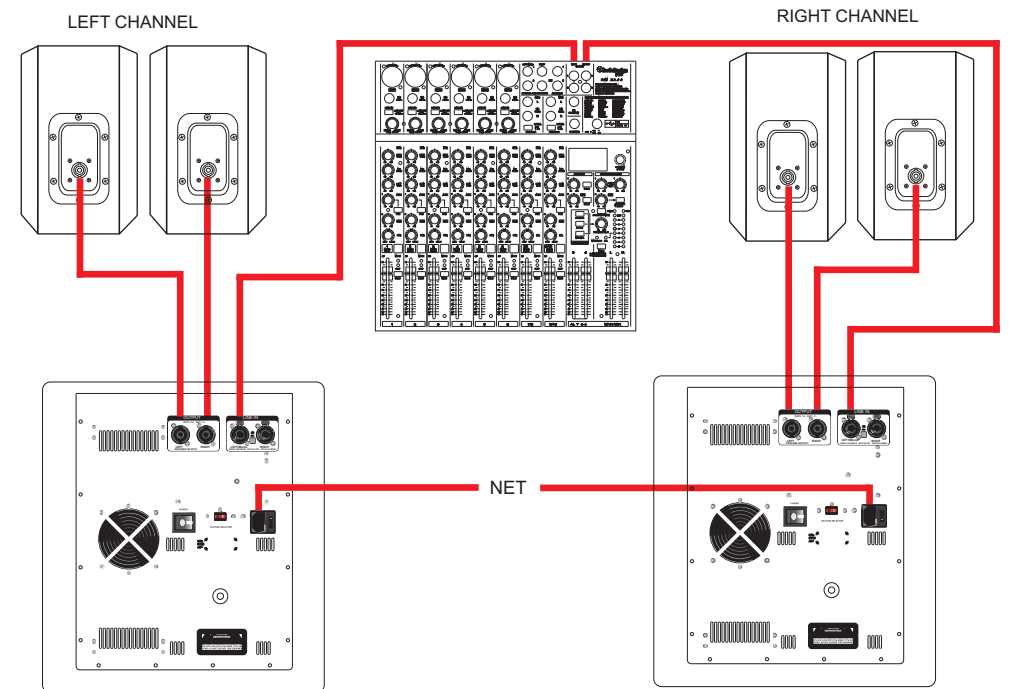

Depending on the chosen configuration, connect the system following the precedent wiring schemes.

#### Connection to the electric net

Check that Power switch  is in position 0 and that net voltage corresponds to the one selected in the system. Connect the supplied electric wire to an electric net socket equipped with a correct ground contact.

#### Satellite connection

Use wires with good quality Speakon plugs. Make sure to rotate the Speakon plugs clockwise up to the lock position.

#### Connection to the mixer

Before making any connection to the mixer make sure the system power switch is Off in order to avoid damages. Remember that electric net power it the last to be switced On and the first to be disconnected after use!

#### System Volume setting

The TRIO CLUB system is provided with clip limiters and peak level indicators separate and independent on all three channels, and doesn't require therefore any special setting procedure.

Thus the system is able to deliver excellent performances, and should be used with input signals at optimal level, starting from kind and quality of the used cables, and the prevention of any kind of distortion.

In fact the presence of distortion doesn't only deliver a poor performance of the system, but it is also a real risk on long periods, to damage the system itself.

We kindly invite you therefore, to strictly follow the following instructions on how to set the level of alla components.