

## Model 93 Temperature limit switch

Features marked with an asterisk (\*) are available only on units manufactured after January 1993 (Version 1.2).

### 1. Mechanical installation

- Prepare panel cutout.
- Install the optional front panel gasket (part no. BO 133 297) if required. Remove the backing from the gasket and apply it around the panel cutout on the *outside of the panel*.
- Slide instrument sleeve into the cutout from the front of the panel.
- Position the mounting bracket on the rear of the instrument sleeve with the 2 clips facing the rear and positioned on the top and bottom of the sleeve.
- While holding the sleeve, slide the mounting bracket towards the panel until the clips engage on the ratchets. While still pulling back on the sleeve, press on the upper left and lower right hand corners of the bracket to seat the mounting bracket. Another push on the clips

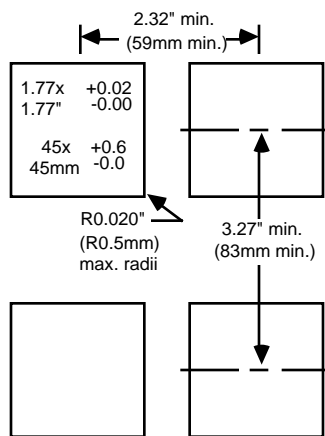

Panel cutout and minimum spacing  
Max. panel thickness: 0.51" (13mm)

with a screwdriver might be necessary to secure the installation.

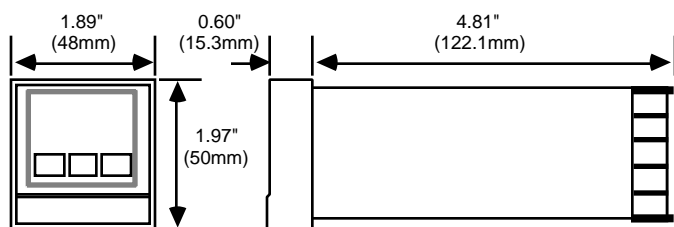

Dimensions

Panel depth: with rear terminal cover: 4.96" (126.1mm)  
with gasket fitted: less 0.060" (1.5mm)

### 2. Electrical connections

**WARNING!** Ensure that the maximum voltage which is applied to the unit power supply, between any two isolated circuits, or between any isolated circuit and ground does not exceed 264Vac.

**Power**  
Respect the polarity of the AC power supply: line wire must be connected to terminal 12, and the neutral must be connected to terminal 11.

**Alarm relay(s)**  
The alarm outputs are failsafe: the relays are de-energized during the alarm condition or power down. The attached alarm circuit should be designed for failsafe operation and fused appropriately. A snubber may be required; see below.

**Snubbers**  
Connect snubbers CZ 140 398 (22nf + 100 ) across the appropriate alarm relay contacts when driving AC inductive loads (mechanical contactors and solenoids). *Do not use snubbers when driving high impedance loads.* The snubber passes 1mA in 120Vac circuits, and 2mA in 240Vac circuits; this is sufficient to hold in certain relays with high impedance coils *and should not be used in such installations.*

**WARNING!** When an alarm contact is to be implemented as part of a failsafe alarm scheme, it is the user's responsibility to verify that the effect of the snubber does not interfere with the operation of the circuit. Certain high impedance circuits are not able to detect a contact opening when the snubber is placed across the contact. In these cases the snubber should not be installed across the relay contact.

**Reset input**  
Connect momentary contact, normally open pushbutton to terminals 6 and 7. Keep wiring run shorter than 3' (1m) and well away from noise generating circuits.

**Input**  
**WARNING!** This temperature limit switch must have its own input sensor. Never connect the input terminals 9 and 10 in parallel with the input of any other instrument, e.g. recorder, controller, etc. The paralleled inputs of other instruments interfere with proper operation of the sensor break detection circuitry and may also impair the measurement accuracy.  
NOTE: The input circuit is NOT isolated from the reset input (terminals 6 and 7).  
Use of shielded, twisted pair is

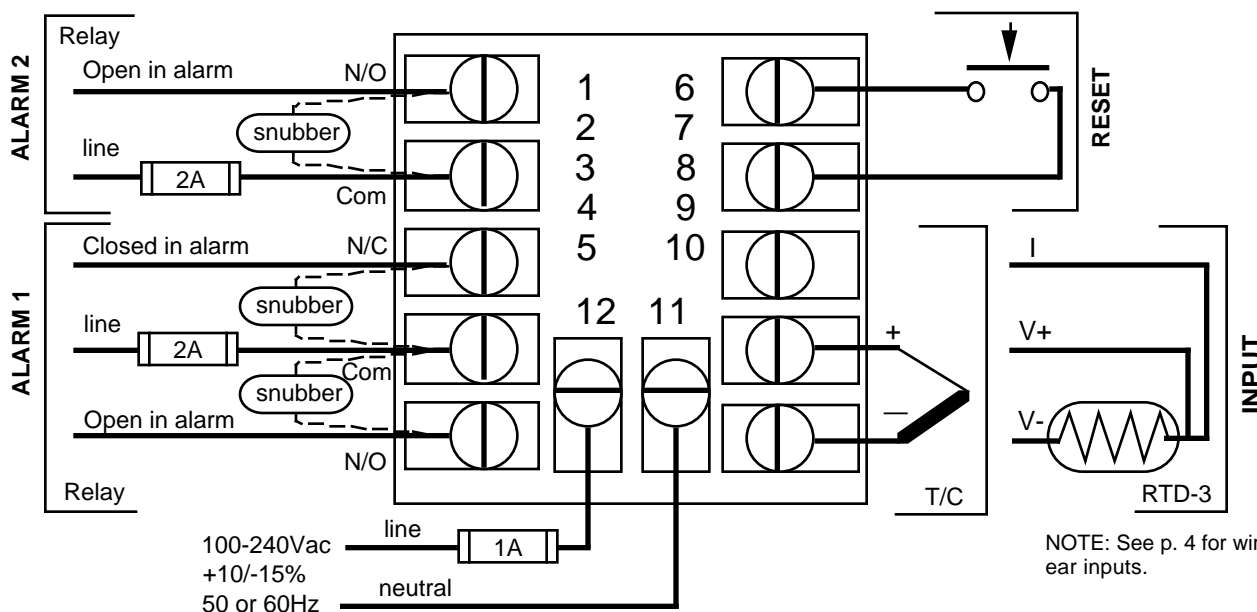

NOTE: See p. 4 for wiring of linear inputs.

recommended. The shield must be connected to terminal 10 even when grounded elsewhere.

- Thermocouple: Use appropriate compensation cable. Keep loop resistance as low as possible (1k maximum).
- RTD: Use 3 copper wires of same length and diameter

### 3. Configuration

#### Procedure

1. Cycle power OFF and ON. Touch and hold secret key when 4-digit configuration code appears *after* self test to enter configuration mode.  
NOTE: Touching the front panel during the start-up self test could lead to erroneous test results.
2. See configuration code with left digit blinking.

(20 /lead maximum resistance).  
• Linear inputs: see page 4.

**Rear terminal cover** (optional)  
After wiring, attach rear terminal cover BD133125 with screw FY133264U001.

3. Enter new code (refer to *Configuration code* table):  
▼ = select digit position (1 through 4)  
▲ = modify digit value.
4. To exit configuration mode do one of these:  
Secret key = accept new configuration; parameter value check follows.  
— = abort; return to previous configuration.

#### Configuration code

##### 1st (left) and 2nd digits

alarm 1 and alarm 2 functions

0	Disabled
1	Deviation low alarm
2	Deviation high alarm
3	Deviation band alarm
4	Full scale low alarm
5	Sensor break alarm
6	Full scale high alarm

##### 3rd digit

full specified range

input sensor type	°F min	°F max	°C min	°C max	
0	RTD—100 Pt, DIN43760	-148	1112	-100	600
1	B—Pt-30%Rh/Pt/6%Rh	1112	3308	600	1820
2	C—W-5%Re/W-26%Re (Hoskins)	32	3902	0	2150
3	E—Chromel™/Adams constantan	-436	1832	-260	1000
4	J—Fe/SAMA constantan	-328	2192	-200	1200
5	K—Chromel™/Alumel™	-418	2502	-250	1372
6	L—Fe/Konstantan	-148	1652	-100	900
7	N—NiCroSil/NiSil	32	2372	0	1300
8	Platinel II™	-418	2543	-250	1395
9	R—Pt-13%Rh/Pt	32	3213	0	1767
A	S—Pt-10%Rh/Pt	32	3213	0	1767
B	T—Cu/Adams constantan	-427	752	-255	400
C	Linear a—2-point entry scaling				
D	Linear b—point-and-span entry scaling				

##### 4th (right) digit

pwr fail

display	remote ack.	alarm	
0	°C	AL1 & 2	no
1	°C	AL1 & 2	yes
2	°C	AL1	no
3	°C	AL1	yes
4	°C	AL2	no
5	°C	AL2	yes
6	°F	AL1 & 2	no
7	°F	AL1 & 2	yes
8	°F	AL1	no
9	°F	AL1	yes
A	°F	AL2	no
B	°F	AL2	yes

#### Configuration example

##### 6646:

- 1st digit (6): full scale (absolute) high latching alarm (AL 1).  
2nd digit (6): full scale (absolute) high latching alarm (AL 2).  
3rd digit (4): type J thermocouple input.  
4th digit (6): display units in °F, remote alarm acknowledgement for both alarms, and power fail alarm disabled.

## 4. Operation

#### BASIC OPERATION

##### Open list procedures

- Measured value is displayed when unit is unattended.
- Depress — once to view display units.
- Depress — again to view AL 1. Push ▲ or ▼ to view alarm 1 setpoint.
- Depress — again to view AL 2. Push ▲ or ▼ to view alarm 2 setpoint.
- To acknowledge (or reset) latching alarms (flashing red AL1 or AL2 lamp); use — until AL 1 (AL 2) appears. Then do either: Method 1—Hold ▲ or ▼ for 5 sec-

onds until **Clr** appears, release, then press the button again.  
\*Method 2—Use “secret key”.

##### Protected list procedures

- To enter protected list: use — until units display (°F, °C or Lin), then “secret key”. Continue with — to view parameter mnemonics.
  - Push ▲ or ▼ to view parameter value. Push ▲ or ▼ again to modify parameter value.
  - To return to measured value display: use “secret key”.
- NOTE: Parameters not pertinent to the unit configuration do not appear in the scroll list.

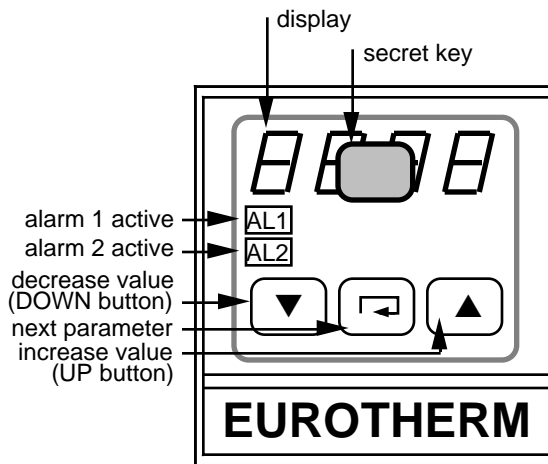

#### LIMIT SWITCH OPERATION

##### Temperature and process alarms

If the measured value enters an alarm condition (defined by the configuration code and the parameter values), then the appropriate red lamp, AL1 or AL2, lights and the corresponding relay de-energizes. The limit switch operation is always latching.

NOTE: Deviation alarm setpoints (d-1 and d-2) are in reference to the alarm setpoints (AL 1 and AL 2).

Examples: deviation low alarm setpoint = **AL 2 - d-2**, deviation high alarm setpoint = **AL 1 + d-1**, deviation band alarm setpoints = **AL 2 ± d-2**.

##### Resetting (acknowledging) alarms

Alarms are acknowledged in the open list (see “Open list procedures”) or by a remote pushbutton.

NOTE: The remote pushbutton can be configured to acknowledge only AL1, only AL2 or both.

##### Sensor fail alarm

Sensor fail detection is always operative. The unit displays **SnSr FAIL** upon detecting at least one of these conditions:

- if the input signal is less than -40mV or greater than +90mV,
- if the input is open circuit, or
- if the unit’s temperature is outside of the 0-55°C operating range (thermocouple inputs only).

The behavior of the relays and the alarm lamps AL1 and AL2 conforms to the table below.

NOTE: Selection of configuration code “5” for digits 1 or 2 enables the alarm relay operation only for sensor fail alarm (and power fail alarm if enabled) and not for any process alarm condition.

#### Alarm condition

Active Cleared

**Before resetting (unacknowledged)**

lamp flashing	relay de-energized	lamp flashing	relay de-energized
---------------	--------------------	---------------	--------------------

**After resetting (acknowledged)**

lamp steady ON	relay de-energized	lamp OFF	relay energized
----------------	--------------------	----------	-----------------

### Power fail alarm

- Manual reset after power restoration. If the power fail alarm is selected (one of the “yes” selections for configuration code digit 4), the limit switch always places both relays in the alarm state (de-energized) upon powering up. A *manual* reset by the operator is thus required to re-energize the alarm output relays. These alarms are acknowledged as all others in the open list or by the remote pushbutton.
- Automatic reset after power restoration. If the power fail alarm is not selected (one of the “no” selections for configuration code digit 4), the limit switch *automatically* re-affirms any alarm existing before the power failure.

### Alarm test

To test the operation of the output relays and the connected circuit, scroll to the appropriate alarm (**AL1** or **AL2**) in the *protected* list and hold ▲ or ▼ until **tESt** appears. Release, then depress the button again to change the state of the relay: if the relay is energized, then the alarm test de-energizes the relay and vice versa. When the button is released, the relay assumes the previous condition determined by the input.

### Adjustable parameters

Mnemonic	Parameter	Adjustable range	Comments
<b>OPEN LIST</b>			
°C, °F, Lin	Display units	View only.	Display units selected in configuration.
AL 1	Alarm 1 setpoint	View only.	To acknowledge latching alarms: Hold UP or DOWN button until “CLr” appears, release, then press the button again. Value adjustable in protected list, below.
AL 2	Alarm 2 setpoint		
<b>PROTECTED LIST</b>			
ConF	Configuration code	View only.	Can be changed upon power up only.
Id	Instrument model ident.	View only: “93”	
dP	Decimal point position for linear inputs a and b	0 to 2 decimal places. Formats: XXXX, XXX.X or XX.XX	Appears for linear inputs only. Affects all parameters displayed in process units.
AL 1	Alarm 1 setpoint	Full scale alarm setpoints and deviation alarm reference levels: configured input sensor range.	Alarm function selected in configuration. “AL 1” setting irrelevant for sensor break alarms: configuration code “5”. To test alarm operation: Hold UP or DOWN button until “tESt” appears, release, then press the button again. Alarm state should toggle.
HY 1	Alarm 1 hysteresis	1°C (or 1°F) to upper range limit Linear inputs: 1 to 9999, 0.1 to 999.9, 0.01 to 99.99	
-d-1	Deviation alarm offset from “AL1”	1°C (or 1°F) to upper range limit Linear inputs: 1 to 9999, 0.1 to 999.9, 0.01 to 99.99	Appears for deviation configurations only. <b>For deviation band alarms, “HY1” must be less than “-d-1”.</b>
AL 2	Alarm 2 setpoint	Same as alarm 1.	Same as alarm 1.
HY 2	Alarm 2 hysteresis		
-d-2	Deviation alarm offset from “AL 2”		
OFSt	Calibration offset	-50.0 to 50.0°C -90.0 to 90.0°F	Appears for temperature inputs only.
LinE	Line frequency	50 Hertz: “50”; 60 Hertz: “60”	Set to line frequency upon installation.

### Display messages

Message	Display condition	User action/comments
<b>INPUT STATUS MESSAGES</b>		
<b>SnSr FAIL</b>	Sensor fail. Input open or reversed; measured value outside of configured range.	Verify input sensor and connections. Message disappears when input signal is reinstated.
<i>flashing value</i>	Display overrange or out of specified accuracy range.	Unit should not be used in this range.
<b>SELF DIAGNOSTIC MESSAGES</b>		
<b>tESt 1111</b>	Internal self test upon power up.	Replace unit if all four 1’s do not light up or fails to go on to “8888” display. Do not touch front panel during self test.
<b>8888</b>	Display test after above self test. Lasts for approximately 3 seconds.	User should verify that all digits and lamps light up to prevent erroneous readings.
<b>EE FAIL</b>	Memory corruption.	Cycle power. Verify and correct all parameter and configuration values. If display persists, replace unit.
<b>Id FAIL</b>	Unit failure.	Replace unit.

Please note the following:

- Conductive pollution, such as carbon dust, must be excluded from the cabinet in which the instrument is mounted.
- Any voltage transients that occur on power supply lines, isolated inputs or outputs must not exceed 2.5V (in series or common mode). If occasional voltage transients of 2.5kV or higher are expected or measured, transient limiting devices should be part of installation.

## LINEAR INPUT SETUP

### Electrical connections

For all inputs use a shielded twisted pair.

- Millivolt inputs (-10 to 70mV).

Connect signal leads directly to input terminals 9 (+) and 10 (-).

- 0-20mA and 4-20mA inputs.

Connect 3.01 shunt (part no. CA 9G3 R01) across input terminals 9 (+) and 10 (-).

• Higher voltage inputs. Voltage divider network is required (resistors supplied by user). Refer to table for suggested values. Resistor specifications: 1%, 0.125W minimum,  $\pm 100$ ppm metal or metal oxide film.

**CAUTION: Use of the shunt or voltage divider inhibits operation of the sensor break detection feature.**

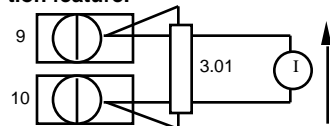

0-20mA and 4-20mA input

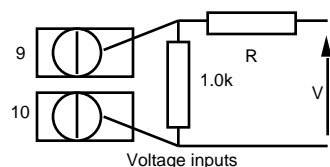

Voltage inputs

Nominal range	R
-20 to 200mV	2.2k
-0.1 to 1 V	15.0k
-0.5 to 5V	75.0k
-1 to 10V	150k
-2.5 to 25V	392k

### Scaling procedure

There are 2 methods for entering and scaling linear inputs:

- Linear a: 2-point scaling (configuration code "C").
- Linear b: point and span scaling (configuration code "D").

#### Linear a and Linear b

1. Set display decimal point position parameter, **dP**, to desired value.
2. If reading the input signal directly from the source, connect source (from signal generator or sensor) to input terminals. Apply a signal equal to a known low value for the first setup point.
3. Scroll through the protected list until **In.Lo**. Press and hold on **▲** or **▼** until **rEAd** appears, release, then push the button again. [Alternatively, if no input signal is required or the exact value is known, the input value in millivolts can be set in with **▲** or **▼**.]

4. Scroll to **dSLo**. Then set in the corresponding display value with **▲** or **▼**.

#### Linear a only

5. Again, if reading the input signal directly from the source, apply a signal equal to a known high value for the second setup point.
6. Scroll through the protects list until **In.Hi**. Press on **▲** or **▼** until **rEAd** appears, release, then push the button again. [Alternatively, if

no input signal is required or the exact value is known, the input value in millivolts can be set in with **▲** or **▼**.]

7. Access **dSHi**. Then set in the corresponding display value with **▲** or **▼**.

#### Linear b only

8. Access **In.Sn**. With **▲** or **▼** set in the input signal span in millivolts.

9. Access **dSSn**. With **▲** or **▼**

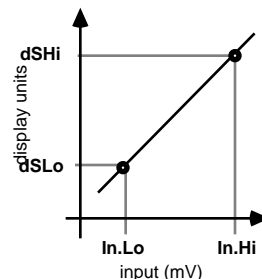

Linear a: 2-point scaling

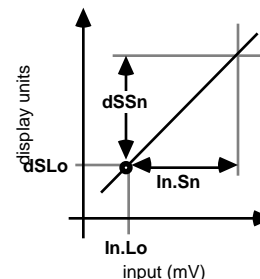

Linear b: point & span scaling

### LINEAR INPUT SCALING

(Replaces "OFSt" parameter in protected list)

Parameter	Description	Range	Notes
<b>In.Lo</b>	Input for low setup point	-9.99 to 70.00mV input signal range	Both linear a and b inputs. To read input signal value from rear terminals: Hold UP or DOWN until "rEAd" appears, release, then press the button again.
<b>dSLo</b>	Display value for low setup point	-999 to 9999, -99.9 to 999.9, or -9.99 to 99.99 process units	Both linear a and b inputs.
<b>In.Hi</b>	Input for high setup point	-9.99 to 70.00mV input signal range	Linear a inputs only. To read input signal value from rear terminals: See procedure for "In.Lo", above.
<b>dSHi</b>	Display value for high setup point	-999 to 9999, -99.9 to 999.9, or -9.99 to 99.99 process units	Linear a inputs only.
<b>In.Sn</b>	Input signal span	0.00 to 70.00mv	Linear b inputs only.
<b>dSSn</b>	Display span	-999 to 9999, -99.9 to 999.9, or -9.99 to 99.99 process units	Linear b inputs only.

### CAUTION!

Before installing, operating or servicing this unit supplied by Eurotherm please read the following:

#### INSTRUCTIONS FOR SAFE USE OF EUROTHERM EQUIPMENT

(Note: These instructions represent good engineering principles and are applicable to all control equipment of the same type, whether from Eurotherm or any other supplier.)

#### ENCLOSURE OF LIVE PARTS

This unit should be installed inside a suitable grounded metal enclosure to prevent live parts being accessible to human hands and metal tools. It is recommended that rear terminal covers (available as an option) be fitted.

#### WIRING

It is important to connect the unit correctly in accordance with the installation data on this sheet.

Wiring should conform to appropriate standards of good practice and local codes and regulations. Conductors should be commensurate with voltage and current ratings of the units.

#### OUT-OF-LIMITS ALARMS

In applications where excessive

deviation of a controlled parameter due to equipment failure could cause damage to machinery or materials, or injury to personnel, it is strongly recommended that an additional separate unit with its own input sensor be used to give alarm indication or to shut down the process or both, as may be appropriate. (Note: The alarm function built into controllers may not give sufficient protection in these circumstances). When the controller alarm function or separate alarm units are used they should be checked for correct operation at regular intervals.

#### CONFIGURATION

Many instrument functions are user selectable from the front panel. It is the user's responsibility to verify that the instrument configuration is correct. Personal injury, property loss and equipment damage could result from an improperly configured instrument.

#### GROUNDING

This instrument has internal circuits which are isolated or "floating." This is necessary to prevent the occurrence of a "ground loop" in signal circuits. To avoid possible shock hazards in the event of an internal fault causing break-

down of insulation, it is recommended that all equipment connected to this unit be enclosed in a grounded metal enclosure. Sheaths of thermocouples (or other sensors) should be properly grounded by a separate conductor (instead of being dependent on grounding via the machine framework).

#### ESD PRECAUTIONS

This instrument contains static sensitive components. Care should be taken to avoid electrostatic discharge (ESD) and thus reduce incidents of damage to the instrument when removed from its sleeve. Any manipulation of an unsleeved instrument should be performed on a conductive surface with the personnel in contact with the surface by means of a grounded, metal or conductive plastic wrist strap with a 1M series resistor.

#### SUPPLY ISOLATORS

Every electrical system should be provided with means for isolating the system from the AC supply to allow safe working during repair and maintenance. SCRs and triacs are not adequate means of isolating the supply, and should always be backed by a suitable

mechanical disconnect switch.

#### HAZARDOUS ATMOSPHERES

This unit is not suitable for use in areas subject to hazardous atmospheres. No Eurotherm product should be connected to a circuit which passes into or through a hazardous area unless appropriate precautions are taken (even though the instrument itself may be located in a safe area). Such an installation should conform to the requirements of the relevant Authority. (In the USA: Factory Mutual Research Corporation and Underwriters' Laboratories, Inc.).

#### PROCEDURE IN THE EVENT OF TROUBLE

Before beginning any investigation of a fault, the electrical supplies to all equipment concerned should be switched off and isolated. Units suspected of being faulty should be disconnected and removed to a properly equipped workshop for testing. There are no user-servicable parts inside this unit.

© 1990, 93, 96  
Eurotherm Controls Inc  
All rights reserved.  
Doc. HA133642 Issue 3 9608