



TU-20HT
Thermoregulator
Operator's Manual

Issue 7

Date of issue:

3rd May 2005

Techne is a trade mark

© Techne 2002

CONTENTS

TU-20HT Operator's Manual	
	<i>page</i>
SAFETY and INSTALATION	
English	4
Français	6
Deutsch	8
Español	10
THE TU-20C	12
Constant Temperature Baths	12
Description	12
Unpacking	13
Set Up	13
SPECIFICATION	
TU-20HT	18
Baths	19
OPERATION	20
When you switch on the TU-20HT	21
Front Panel controls	21
Setting the Operating Temperature	24
After Use	24
Setting the overtemperature cutout	25
RS232 Serial Interface	26
Sending Data to a PC	26
ADDITIONAL INFORMATION	27
Operator maintenance	27
Calibration	28
Replacement parts	29
Accessories	29

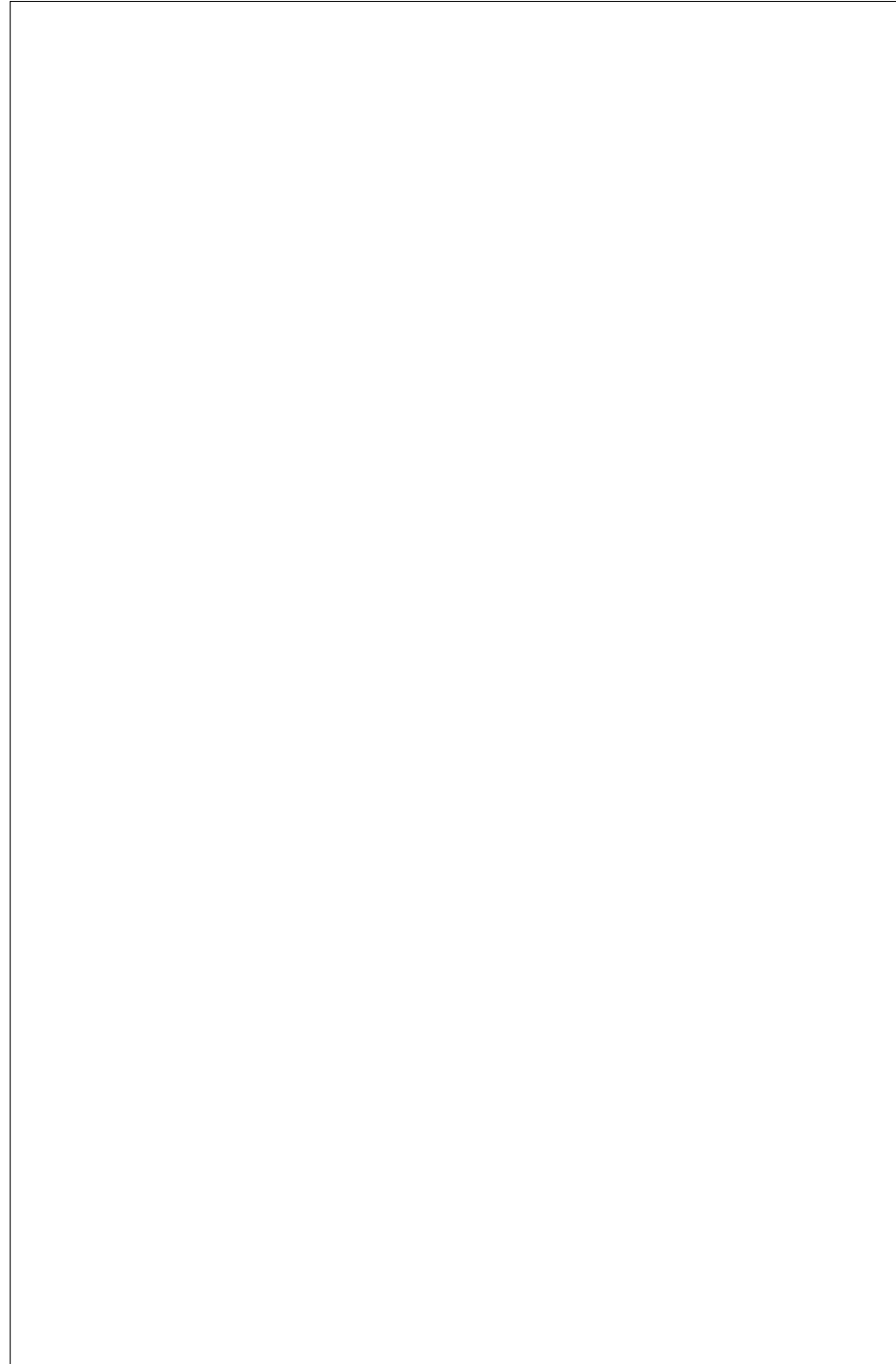

NOTES

Introduction

Please read all the information in this booklet before using the unit.

Warning

HIGH TEMPERATURES ARE DANGEROUS: they can cause serious burns to operators and ignite combustible material.

Techne have taken great care in the design of these units to protect operators from hazards, but Operators should pay attention to the following points:

- USE CARE AND WEAR PROTECTIVE GLOVES TO PROTECT HANDS;
- DO NOT put hot objects on or near combustible objects;
- DO NOT operate the unit close to inflammable liquids or gases;
- DO NOT place any liquid directly in your unit;
- At all times USE COMMON SENSE.

Operator Safety

All Operators of Techne equipment must have available the relevant literature needed to ensure their safety.

It is important that only suitably trained personnel operate this equipment, in accordance with the instructions contained in this manual and with general safety standards and procedures. If the equipment is used in a manner not specified by Techne the protection provided by the equipment to the Operator may be impaired.

All Techne units have been designed to conform to international safety requirements and are fitted with an overtemperature cutout. On some models, the cutout is adjustable and should be set to suit the application. On all other models the cutout is preset to protect the unit.

If a safety problem should be encountered, switch off at the mains socket and remove the plug from the supply.

Installation

1. All Techne units are supplied with a power cable. This may be integral or plug-in.
2. Before connecting the mains supply, check the voltage against the rating plate. The rating plate is on the rear of the unit. Connect the mains cable to a suitable plug according to the table below.

Note that the unit must be earthed to ensure proper electrical safety.

Connections	220V-240V	110V-120V
Live	Brown	Black
Neutral	Blue	White
Earth	Green/yellow	Green

The fused plug supplied with the mains lead for use in the UK is fitted with the following value fuse to protect the cable: 10AMP.

The fuse in the unit protects the unit and the operator

Note that units marked 230V on the rating plate work at 220V; units marked 120V work at 110V. In both cases, however, the heating rate will degrade by approximately 8%.

3. Plug the mains cable into the socket on the rear of the unit.
4. Place the unit on a suitable bench or flat workspace, or in a fume cupboard if required, ensuring that the air inlet vents are free from obstruction.
5. Note that the following symbols may be next to the indicator lamps on the front panel of the units and have the following meanings:

~	: the power indicator
⏏	: the heater indicator
⚡	: the overtemperature indicator

6. Symbols on or near the power switch of the unit have the following meanings:

I	: mains switch On
O	: mains switch Off

After use

When you have finished heating samples, remember that parts of the unit – the tubes, blocks and associated accessories – may be very hot. Take the precautions listed earlier.

Guarantee

The unit is guaranteed against any defect in material or workmanship for the period specified on the enclosed guarantee card. This period is from the date of purchase, and within this period all defective parts will be replaced free of charge provided that the defect is not the result of misuse, accident or negligence. Servicing under this guarantee should be obtained from the supplier.

Notwithstanding the description and specification(s) of the units contained in the Operator's Manual, Techne hereby reserves the right to make such changes as it sees fit to the units or to any component of the units.

This Manual has been prepared solely for the convenience of Techne customers and nothing in this Instruction Book shall be taken as a warranty, condition or representation concerning the description, merchantability, fitness for purpose or otherwise of the units or components.

Operator maintenance

NOTE: THAT THIS EQUIPMENT SHOULD ONLY BE DISMANTLED BY PROPERLY TRAINED PERSONNEL.

REMOVING THE SIDE, FRONT OR REAR PANELS EXPOSES POTENTIALLY LETHAL MAINS VOLTAGES.

THERE ARE NO OPERATOR MAINTAINABLE PARTS WITHIN THE EQUIPMENT.

In the unlikely event that you experience any problems with your unit which cannot easily be remedied, you should contact your supplier and return the unit if necessary. Please include any details of the fault observed and remember to return the unit in its original packing. Techne accept no responsibility for damage to units which are not properly packed for shipping: if in doubt, contact your supplier. See the Decontamination Certificate supplied with your unit.

1. Cleaning

Before cleaning your unit ALWAYS disconnect it from the power supply and allow it to cool below 50° C.

Your unit can be cleaned by wiping with a damp soapy cloth. Care should be exercised to prevent water from running inside the unit. Do not use abrasive cleaners.

2. Overtemperature cutout

In the event of no heater power, check the mains plug and lead. Repeated operation of the cutout indicates a serious fault: you may need to return the unit to your supplier for repair.

3. Fuses

Your unit is protected by one or two fuses. These should only be changed by suitably qualified personnel.

If the fuses blow persistently, a serious fault is indicated and you may need to return the unit to your supplier for repair.

Contact Information

For technical, sales or servicing information, contact your local Techne dealer or,

Barloworld Scientific Ltd
Beacon Road, Stone
Staffordshire
ST15 0SA, United Kingdom
Telephone: +44(0)1785 812121
Fax: +44(0)1785 813748
e-mail: equipment@barloworld-scientific.com

or,

Techne Inc, 3 Terri Lane,
Suite 10, Burlington,
New Jersey 08016, USA.
Telephone: 609-589-2560
Toll free: 800-225-9243 ext 306
Fax: 609-589-2571
e-mail: labproducts@techneusa.com
Web site: www.techneusa.com

Introduction

Veillez lire attentivement toutes les instructions de ce document avant d'utiliser l'appareil.

Avertissement

DANGER DE TEMPERATURES ELEVEES : les opérateurs peuvent subir de graves brûlures et les matériaux combustibles risquent de prendre feu.

Techne a apporté un soin tout particulier à la conception de ces appareils de façon à assurer une protection maximale des opérateurs, mais il est recommandé aux utilisateurs de porter une attention spéciale aux points suivants :

- PROCEDER AVEC SOIN ET PORTER DES GANTS POUR SE PROTEGER LES MAINS.
- NE PAS poser d'objets chauds sur ou près de matériaux combustibles.
- NE PAS utiliser l'appareil à proximité de liquides ou de gaz inflammables.
- NE PAS verser de liquide directement dans l'appareil.
- FAIRE TOUJOURS PREUVE DE BON SENS.

Sécurité de l'opérateur

Tous les utilisateurs de produits Techne doivent avoir pris connaissance des manuels et instructions nécessaires à la garantie de leur sécurité.

Important : cet appareil doit impérativement être manipulé par un personnel qualifié et utilisé selon les instructions données dans ce document, en accord avec les normes et procédures de sécurité générales. Dans le cas où cet appareil ne serait pas utilisé selon les consignes précisées par Techne, la protection pour l'utilisateur ne serait alors plus garantie.

Tous les appareils Techne sont conçus pour répondre aux normes de sécurité internationales et sont dotés d'un coupe-circuit en cas d'excès de température. Sur certains modèles, ce coupe-circuit est réglable pour s'adapter à l'application désirée. Sur d'autres modèles, il est pré-réglé en usine pour assurer la protection de l'appareil.

Dans le cas d'un problème de sécurité, coupez l'alimentation électrique au niveau de la prise murale et enlevez la prise connectée à l'appareil.

Installation

1. Tous les appareils Techne sont livrés avec un câble d'alimentation qui peut être intégré à l'appareil ou à raccorder.
2. Avant de brancher l'appareil, vérifiez la tension requise indiquée sur la plaque d'identification. Raccordez le câble électrique à la prise appropriée en vous reportant au tableau ci-dessous. **Il est important que l'appareil soit relié à la terre pour assurer la protection électrique requise.**

<i>Connexions</i>	<i>220V-240 V</i>	<i>110V-120 V</i>
Phase	marron	noir
Neutre	bleu	blanc
Terre	vert/jaune	vert

Le fusible à l'intérieur de l'appareil est destiné à assurer la protection de l'appareil et de l'opérateur.

Remarque : les appareils dont la plaque indique 230 V peuvent fonctionner sur 220 V, et ceux dont la plaque indique 120 V peuvent fonctionner sur 110 V. Dans les deux cas cependant, la capacité de chauffage diminuera d'environ 8 %. La plaque d'identification se trouve à l'arrière de l'appareil.

3. Raccordez le câble d'alimentation à la prise située à l'arrière de l'appareil.
4. Placez l'appareil sur un plan de travail ou surface plane, ou le cas échéant, dans une hotte d'aspiration, en s'assurant que les trous d'aération ne soient pas obstrués.
5. Les symboles ci-dessous situés à côté des témoins lumineux sur la face avant de l'appareil ont la signification suivante :

 : témoin d'alimentation

 : témoin de chauffage

 : témoin d'excès de température

6. Les symboles situés sur ou à côté de l'interrupteur de l'appareil ont la signification suivante :

I : marche

O : arrêt

Après utilisation

Lorsque vous avez fini de chauffer les échantillons, n'oubliez pas que certaines parties de l'appareil - les éprouvettes, leurs supports et autres accessoires - risquent d'être très chaudes. Il est donc recommandé de toujours prendre les précautions citées plus haut.

Garantie

L'appareil est garanti contre tout défaut ou visde fabrication pour la durée figurant sur la carte de garantie, à compter de la date d'achat de l'appareil. Au cours de cette période, toutes les pièces défectueuses seront remplacées gratuitement, dans la mesure où la défaillance n'est pas due à une mauvaise utilisation, un accident ou une négligence. Toute réparation sous garantie sera effectuée par le fournisseur.

Malgré la description et les spécifications de l'appareil données dans le manuel de l'utilisateur, Techne se réserve le droit d'effectuer les changements nécessaires à l'appareil ou à tout élément qui entre dans sa composition.

Ce manuel a été exclusivement rédigé à l'attention des clients de Techne, et aucun élément de ce guide d'instructions ne peut être utilisé comme garantie, condition ou représentation concernant la description, commercialisation, adaptation aux conditions d'utilisation ou autre des appareils ou leurs composants.

Entretien utilisateur

IMPORTANT : CET APPAREIL NE PEUT ETRE DEMONTE QUE PAR DU PERSONNEL QUALIFIE. LORSQUE LES PANNEAUX SONT DEMONTES, L'OPERATEUR EST EXPOSE A DES TENSIONS QUI PEUVENT ETRE MORTELLES.

CET APPAREIL NE CONTIENT AUCUN ELEMENT QUI DEMANDE UN ENTRETIEN DE LA PART DE L'UTILISATEUR.

Dans le cas peu probable où votre appareil présente un défaut de fonctionnement auquel il est difficile de remédier, il est alors préférable de contacter votre fournisseur et, le cas échéant, de renvoyer le matériel. Veuillez inclure une description détaillée du problème constaté et retourner l'appareil dans son emballage d'origine. Techne ne sera pas tenu responsable des dommages subis par tout appareil dont l'emballage est inadéquat pour le transport. Pour plus de sûreté, contactez votre fournisseur. Voir le certificat de décontamination livré avec le produit.

1. Nettoyage

Avant de nettoyer l'appareil, assurez-vous TOUJOURS que le câble d'alimentation est déconnecté et laissez la température redescendre en dessous de 50 °C.

Utilisez un chiffon imprégné d'eau savonneuse pour nettoyer l'appareil. Veillez à ne pas introduire d'eau dans l'appareil. N'utilisez pas de produits abrasifs.

2. Coupe-circuit d'excès de température

- En l'absence de puissance de chauffe, vérifiez la prise et le câble d'alimentation puis réglez la commande du coupe-circuit (si votre appareil est doté de ce mécanisme).
- Si la sécurité se déclenche trop souvent, il s'agit d'un problème plus sérieux. Nous vous conseillons dans ce cas de prendre contact avec votre fournisseur pour réparation.

3. Fusibles

La protection de l'appareil est assurée par un ou deux fusibles dont le remplacement ne peut être effectué que par un personnel qualifié.

Si les fusibles sautent sans arrêt, il s'agit d'un problème sérieux. Nous vous conseillons dans ce cas de prendre contact avec votre fournisseur pour réparation.

Einleitung

Bitte lesen Sie diese Bedienungsanleitung komplett bevor Sie dieses Gerät benutzen.

Warnung

HOHE TEMPERATUREN SIND GEFÄHRLICH: sie können dem Bediener ernsthafte Verletzungen zufügen und brennbare Materialien können sich leicht entzünden.

Techne hat bei der Konstruktion dieses Gerätes sehr darauf geachtet, daß der Bediener vor Gefahren geschützt ist. Dennoch sollten Sie auf die folgenden Punkte achten:

- SEIEN SIE VORSICHTIG UND TRAGEN SIE SCHUTZHANDSCHUHE
- Legen Sie heiße Gegenstände NICHT auf oder in die Nähe von leicht brennbaren Materialien; vermeiden Sie Arbeiten in der Nähe von leicht entzündbaren Flüssigkeiten oder Gasen.
- Bringen sie KEINE Flüssigkeiten direkt in Ihr Gerät.
- Benutzen Sie immer den normalen Menschenverstand

Sicherheit des Anwenders

Alle Benutzer von Techne Geräten müssen Zugang zu der entsprechenden Literatur haben, um ihre Sicherheit zu gewährleisten.

Es ist wichtig, daß diese Geräte nur von entsprechend geschultem Personal betrieben werden, das die in dieser Gebrauchsanweisung enthaltenen Maßnahmen und allgemeine Sicherheitsbestimmungen und -vorkehrungen beachtet. Wenn das Gerät anders eingesetzt wird als vom Hersteller empfohlen, kann dies die persönliche Sicherheit des Anwenders beeinträchtigen. Die Geräte von Techne entsprechen den internationalen Sicherheitsbestimmungen und sind mit einem automatischen Übertemperaturabschalter ausgestattet. Bei einigen Modellen ist der Übertemperaturabschalter verstellbar und sollte je nach Anwendung entsprechend eingestellt werden. Bei allen anderen Modellen ist der Temperaturschutz voreingestellt um Schäden am Gerät zu vermeiden. Wenn ein Sicherheitsproblem auftreten sollte, muß das Gerät ausgeschaltet und vom Stromnetz getrennt werden.

Installation

1. Alle Techne Geräte werden mit einem Stromanschlußkabel geliefert. Dieses ist entweder fest mit dem Gerät verbunden oder zum Einstecken.
2. Vergleichen Sie, ob die Spannung Ihrer Stromversorgung mit den Angaben auf dem Typenschild des Gerätes übereinstimmen. Verbinden Sie das Stromanschlußkabel mit einer geeigneten Stromversorgung gemäß der nächstehenden Tabelle. **Achtung:** Das Gerät muß geerdet sein, um die elektrische Sicherheit zu gewährleisten!

<i>Verbindungen</i>	<i>220V-240V</i>	<i>110V-120V</i>
Stromführend	Braun	Schwarz
Neutral	Blau	Weiß
Erde	Grün/Gelb	Grün

Geräte, die für 230 Volt ausgelegt sind, können auch bei 220 Volt arbeiten, Geräte für 120 Volt auch bei 110 Volt. In beiden Fällen verringert sich die Aufheizrate um ca. 8%. Das Typenschild befindet sich hinten am Gerät.

3. Stecken Sie das Stromkabel in die vorgesehene Buchse hinten am Gerät.
4. Stellen Sie das Gerät auf eine ebene Arbeitsfläche bzw. (falls erforderlich) unter einen Laborabzug. Beachten Sie, daß die Entlüftungsrippen immer frei zugänglich sind.
5. Wenn die Anzeigenlämpchen an der Vorderseite leuchten, hat dies folgende Bedeutung:

~ : Gerät ist eingeschaltet

⏏ : Gerät heizt

⚡ : Übertemperaturschutz ist ausgelöst

6. Die Symbole auf oder neben dem EIN/AUS-Schalter an der Geräterückseite bedeuten:

I : An

O : Aus

Nach dem Gebrauch

Vergessen Sie nicht, daß Teile des Gerätes (die Gefäße, die Blöcke und andere Zubehörteile) nach dem Erhitzen von Proben noch sehr heiß sein können. Bitte beachten Sie die oben genannten Vorsichtsmaßnahmen.

Garantie

Die Garantiedauer des Gerätes ist auf der beiliegenden Garantiekarte angegeben und schließt Fehler im Material oder der Verarbeitung ein. Die Garantiedauer beginnt am Tag des Einkaufs. Sämtliche defekte Teile werden innerhalb dieses Zeitraumes kostenlos ersetzt unter der Voraussetzung, daß dem Defekt keine unsachgemäße Handhabung, Fahrlässigkeit oder ein Unfall zugrundeliegt. Der unter diese Garantie fallende Service wird vom Lieferanten geleistet.

Ungeachtet der in dieser Gebrauchsanweisung enthaltenen Beschreibungen und Spezifikationen, behält sich Techné hiermit das Recht vor, Änderungen an den Geräten bzw. an einzelnen Geräteteilen durchzuführen.

Diese Gebrauchsanleitung wurde ausschließlich dazu erstellt, um Kunden die Handhabung der Techné-Geräte zu erleichtern. Nichts in dieser Gebrauchsanleitung darf als Garantie, Bedingung oder Voraussetzung verstanden werden, sei es die Beschreibung, Marktgängigkeit, Zweckdienlichkeit oder sonstiges bezüglich der Geräte oder deren Bestandteile.

Wartung durch den Bediener

BEACHTEN SIE, DASS DIESES GERÄT NUR VON TECHNISCHEN FACHKRÄFTEN GEÖFFNET UND DEMONTIERT WERDEN DARF.

DURCH ENTFERNEN DES GERÄUSES ODER GEHÄUSETEILEN SIND BAUTEILE MIT LEBENGEFÄHRLICHEN SPANNUNGEN FREI ZUGÄNGLICH.

IM INNERN DES GERÄTES BEFINDEN SICH KEINE TEILE, DIE VOM ANWENDER GEWARTET WERDEN MÜSSEN.

Falls Ihr Gerät nicht ordnungsgemäß arbeitet, wenden Sie sich an Ihren Lieferanten oder senden Sie das Gerät wenn nötig zurück. Fügen Sie eine genaue Beschreibung des Defektes bei. Verpacken Sie das Gerät möglichst im Originalkarton. Bitte beachten Sie, daß Techné keine Haftung bei Transportschäden aufgrund unzureichender Verpackung übernehmen. Setzen Sie sich im Zweifelsfall mit Ihrem Lieferanten in Verbindung. Bitte beachten Sie die Entgiftungsbescheinigung, die Sie mit dem Gerät erhalten haben.

1. Reinigen

Bevor Sie Ihr Gerät reinigen, sollten Sie

- zuerst den Netzstecker ziehen
- das Gerät unter 50°C abkühlen lassen.

Ein feuchtes Tuch mit Seifenlösung reinigt Ihr Gerät am besten. Achten Sie darauf, daß kein Wasser in das Gerät gelangt. Verwenden Sie keine Scheuermittel.

2. Übertemperaturabschalter

- Der Übertemperaturschutz ist ein empfindliches mechanisches Teil. Schon eine Erschütterung kann diesen auslösen.
- Falls die Heizung nicht funktioniert, überprüfen Sie zuerst Netzstecker und Kabel. Setzen Sie dann den Übertemperaturabschalter (an der Rückseite des Gerätes) wieder zurück, indem Sie den roten Knopf einmal bis zum Anschlag drücken.
- Wenn der Übertemperaturabschalter wiederholt auslöst, liegt ein größerer Defekt vor. Das Gerät muß zur Reparatur an Ihren Lieferanten eingeschickt werden.

3. Sicherungen

Die Stromzuleitung ist durch ein oder zwei Sicherungen geschützt. Diese sollten nur durch qualifiziertes Fachpersonal ausgetauscht werden. Wenn die Sicherung wiederholt durchbrennt, liegt ein größerer Defekt vor. Das Gerät muß zur Reparatur an Ihren Lieferanten eingeschickt werden.

Introducción

Le rogamos lea cuidadosamente la información contenida en este folleto antes de manipular el aparato.

Aviso

LAS TEMPERATURAS ELEVADAS SON PELIGROSAS: pueden causarle graves quemaduras y provocar fuego en materiales combustibles.

Techne ha puesto gran cuidado en el diseño de estos aparatos para proteger al usuario de cualquier peligro; aún así se deberá prestar atención a los siguientes puntos:

- EXTREME LAS PRECAUCIONES Y UTILICE GUANTES PARA PROTEGERSE LAS MANOS;
- NO coloque objetos calientes encima o cerca de objetos combustibles;
- NO maneje el aparato cerca de líquidos inflamables o gases;
- NO introduzca ningún líquido directamente en el aparato;
- UTILICE EL SENTIDO COMUN en todo momento.

Seguridad del usuario

Todos los usuarios de equipos Techne deben disponer de la información necesaria para asegurar su seguridad.

De acuerdo con las instrucciones contenidas en este manual y con las normas y procedimientos generales de seguridad, es muy importante que sólo personal debidamente capacitado opere estos aparatos. De no ser así, la protección que el equipo le proporciona al usuario puede verse reducida.

Todos los equipos Techne han sido diseñados para cumplir con los requisitos internacionales de seguridad y traen incorporados un sistema de desconexión en caso de sobretemperatura. En algunos modelos el sistema de desconexión es variable, lo que le permite elegir la temperatura según sus necesidades. En otros, el sistema de desconexión viene ya ajustado para evitar daños en el equipo. En caso de que surgiera un problema de seguridad, desconecte el equipo de la red.

Instalación

1. Todos los aparatos Techne se suministran con un cable de alimentación. Puede ser fijo o independiente del aparato.
2. Antes de conectarlo, compruebe que el voltaje corresponde al de la placa indicadora. Conecte el cable de alimentación a un enchufe adecuado según la tabla expuesta a continuación. El equipo debe estar conectado a tierra para garantizar la seguridad eléctrica.

<i>Conexiones</i>	220V-240V	110V-120V
Linea	Marrón	Negro
Neutro	Azul	Blanco
Tierra	Verde/amarillo	Verde

Asegúrese de que los equipos marcados 230V en la placa indicadora funcionan a 220V y de que los equipos marcados 120V funcionan a 110V. No obstante, en ambos casos la velocidad de calentamiento se verá reducida en un 8% aproximadamente. La placa indicadora está situada en la parte posterior del equipo.

3. Conecte el cable a la toma de tensión en la parte posterior del equipo.
4. Sitúe el aparato en un lugar apropiado tal como una superficie de trabajo plana, o si fuera necesario incluso en una campana con extractor de humos, asegurándose de que las entradas de aire no queden obstruidas.
5. Los símbolos, que pueden aparecer junto a las luces indicadoras en el panel frontal del equipo, tienen los siguientes significados:

 : Indicador de potencia

 : Indicador del calor

 : Indicador de sobretemperatura

6. Los símbolos que se encuentran en o cerca del interruptor de alimentación tienen los siguientes significados:

I : Interruptor principal encendido

O : Interruptor principal apagado

Después de su uso

Cuando haya finalizado el calentamiento de muestras, recuerde que las piezas del equipo, tales como tubos, bloques y demás accesorios, pueden estar muy calientes. Tome las precauciones mencionadas anteriormente.

Garantía

Este aparato está garantizado contra cualquier defecto material o de fabricación durante el periodo especificado en la tarjeta de garantía adjunta. Este plazo inicia a partir de la fecha de compra, y dentro de este periodo todas las piezas defectuosas serán reemplazadas gratuitamente siempre que el defecto no sea resultado de un uso incorrecto, accidente o negligencia. Mientras se encuentre bajo garantía las revisiones las debe llevar a cabo el proveedor.

A pesar de la descripción y las especificaciones de los aparatos contenidas en el Manual del Usuario, Techne se reserva por medio de este documento el derecho a efectuar los cambios que estime oportunos tanto en los aparatos como en cualquier componente de los mismos.

Este manual ha sido preparado exclusivamente para los clientes de Techne y nada de lo especificado en este folleto de instrucciones se tomará como una garantía, condición o aseveración de la descripción, comerciabilidad o adecuación para cualquier fin específico de los aparatos o sus componentes.

Mantenimiento

ESTE APARATO DEBE SER DESMONTADO SOLO Y EXCLUSIVAMENTE POR PERSONAL DEBIDAMENTE CAPACITADO.

EL RETIRAR LOS PANELES SUPONE DEJAR AL DESCUBIERTO TENSION DE LA RED PELIGROSA. EL EQUIPO NO CONSTA DE NINGUNA PIEZA DE CUYO MANTENIMIENTO SE PUEDA ENCARGAR EL USUARIO.

En el caso improbable de que experimentara algún problema con su aparato que no pudiera resolver con facilidad, debería ponerse en contacto con su proveedor y devolverlo si fuera necesario. Indique de forma detallada todos los defectos que haya notado y devuelva el equipo en su embalaje original. Techne no aceptará responsabilidad alguna por daños causados en equipos que no estuvieran debidamente embalados para su envío; si tuviera alguna duda, póngase en contacto con su proveedor. Sírvase consultar el Certificado de Descontaminación suministrado con su aparato.

1. Limpieza

Antes de limpiar su aparato, desconéctelo SIEMPRE de la fuente de alimentación y permita que se enfríe por debajo de los 50°C.

Este aparato se puede limpiar pasándole un paño húmedo enjabonado. Hágalo con cuidado para evitar que caiga agua dentro del mismo. No utilice limpiadores abrasivos.

2. Desconexión en caso de sobretemperaturas

El sistema de desconexión en caso de sobretemperaturas es un dispositivo mecánico sensible (una sacudida mecánica podría desconectarlo).

- Si el calefactor no recibiera alimentación, compruebe el enchufe y el cable de la toma de corriente; a continuación vuelva a ajustar el control del dispositivo (si su equipo lo lleva montado).
- Una desconexión repetida indicaría una avería grave; puede que tenga que devolverle el aparato a su proveedor para su reparación.

3. Fusibles

Su aparato está protegido por uno o dos fusibles. Sólo deben cambiarlos personal debidamente capacitado.

Si los fusibles se fundieran repetidamente, esto indicaría una avería grave y puede que tuviera que devolverle el aparato a su proveedor para su reparación.

THE TU-20HT

Make sure you have read this manual carefully before you use the thermoregulator.

The Calibration Bath

Techne supply a range of liquid calibration baths from 5 to 12 litres on which you can fit one of the thermoregulator range of units. The bath inner containers are manufactured from stainless steel, for maximum corrosion resistance. The 5 and 7 litre baths are deep drawn with large easy clean corner radii. The 12 litre bath is of welded construction.

Description

The thermoregulator is designed to fit all standard laboratory baths, especially Techne baths. It will heat, circulate and safely control the temperature of the liquid in the bath within precise limits.

The TU-20HT will control the temperature of the liquid in a suitable bath within the range -40°C to 250°C (see the specification for details). However, temperatures from -40°C to "5°C above ambient" require an additional cooling system such as a Techne Fridge unit.

The instrument consists of the following main parts:

- A base moulding in PPS plastic.
- Pump support legs and pump assembly in Victrex Peek.
- A heater assembly in Stainless Steel.
- A base plate made from stainless steel to which are mounted the motor, overtemperature cut-out, mains switch, fuse holder and PCB assembly.
- A cover made from Noryl plastic to which is fitted the digital controls.

The bath temperature is monitored and controlled by a PRT in conjunction with a 3 term controller.

Overtemperature protection is provided by means of an adjustable cutout which also activates an audible alarm. The pump motor and the transformer are also fitted with thermal fuses.

A portable clamp or a bridge piece are available as alternative ways of fixing the thermoregulator to a bath.

Unpacking

When unpacking the unit, check that the following have been removed from the packing: The TU-20HT unit; a Guarantee card; a De-contamination Certificate.

Within the guarantee period, shown on the Guarantee Card, we undertake to supply replacements free of charge for parts which may on examination prove to be defective, provided that the defect is not the result of misuse, accident or negligence. Any instrument requiring service under this guarantee should be sent to the supplier through whom it was purchased, or, in the case of difficulty, it should be carefully packed in its original packing and consigned, carriage paid, to us. Techne takes no responsibility for returned goods damaged in transit.

Returned goods will not be processed without a Returns Authorisation Number. Call + (44) (0)1223 832401 for a number. On all correspondence, please quote the Serial Number in full and/or the Sales Order Number. **Please write the Returns Number on the outside of any packing.**

Set Up

- 1 Ensure that the bath is set up on a flat level surface.
- 3 Fit the unit securely to the bath using the correct bridge piece for the unit/ bath or a portable clamp, see the list of accessories. THE UNIT MUST ALWAYS BE MOUNTED WITH THE BACK AND THE SWITCH END OUTSIDE THE AREA OF THE BATH. This will reduce the infiltration of hot vapours into the cooling system of the thermoregulator. Ensure that at all times the air inlet and outlet remain clear of obstructions. Free circulation of air inside the unit is essential for proper cooling of the electronics and pump motor.

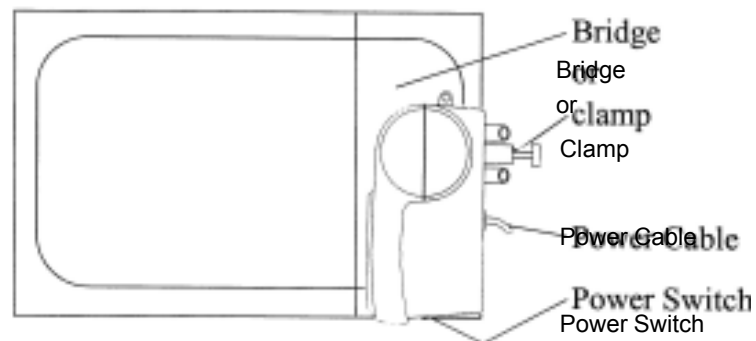

- 3 Use the M4 screw provided with the bridge kit to secure the bridge piece to the thermoregulator at the heater end of the thermoregulator, do not over tighten it. Thumb screw 2 secures both the unit and the bridge to the bath. Thumb screw 3 secures both the cover and the bridge to the bath. Thumb screw 4 is fitted at Techne and secures the cover to the bridge. A bung is provided to seal off the thermometer hole in the bridge piece if a thermometer is not used. It is necessary to fit this bung to reduce heat losses and prevent steam or other vapours getting to the thermoregulator.

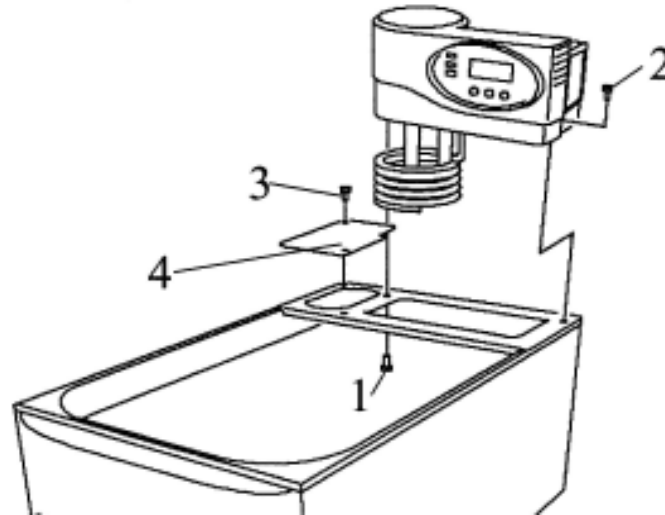

- 4 If you do not want to use a bridge piece to secure the unit to a bath then you must use a clamp. The clamp bracket fits between the pump legs in the slot provided. Slide the bracket into the slot and use the two screws in clamp kit to secure the clamp to the unit.

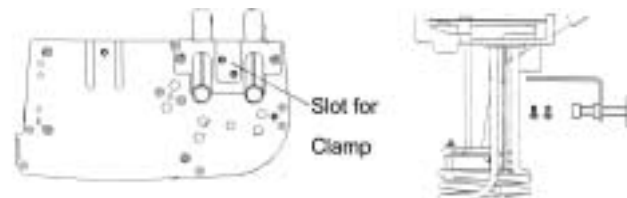

- 5 A cooling coil, which is an optional extra see the list of accessories at the end of this manual, will give control for temperatures between 5°C above ambient and 5°C above the temperature of the water supply.

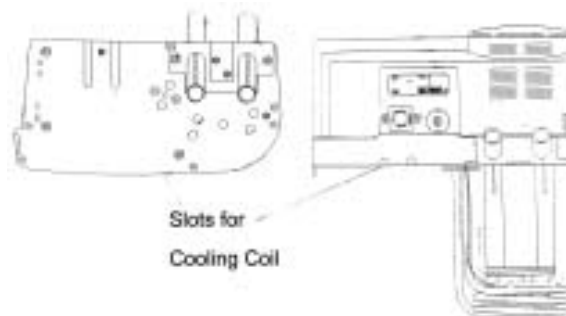

A cooling coil can be fitted to the thermoregulator just below the overtemperature cutout reset button. Connect a hose from a tap to one end of the coil and from the other end of the coil to drain. Adjust the water flow to give the required cooling.

If you are using the thermoregulator on certain baths, for example the Techne Calibration Bath 7 litre, you will not be able to fit a cooling coil. The calibration baths are fitted with their own cooling coil.

- 6 For lower temperatures, a Dip Cooler such as a Techne RU-200 or RU-500 is required. Alternatively you could use either the RB-5A or the RB-12A Techne refrigerated baths, then these have integral fridge coils and no additional cooling is required.

See the instruction Manuals for these units for connections and setup.

- 7 If a thermometer is to be used it may be fitted in the end of the top cover using the O-ring, supplied with the unit, between the two lugs. If a bridge is fitted it is necessary to remove the blanking plug.

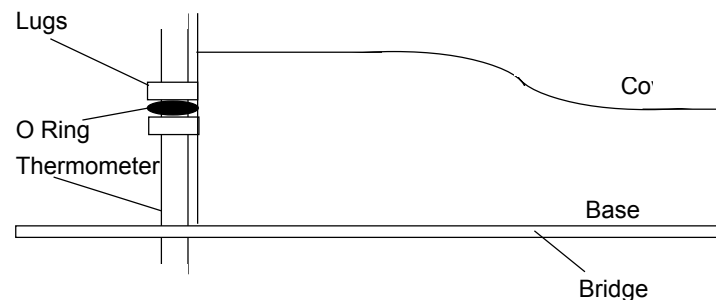

- 8 Fill the bath to between the minimum and maximum levels stated in the specification.

If you are using oil at the highest temperatures, remember that they will expand as the temperature rises. Even if you fill the bath with oil to the minimum level, it may well reach the maximum level before the top temperature is reached. Take all precautions and monitor the level through the full range.

If water is used, demineralised water is preferred to reduce the formation of scale. If scale should form, use only mild de-scaling agents to remove it. DO NOT attempt to hammer, chip or scrape the deposits from the surface of the bath

- 9 Recommended liquids:

<i>Temperature</i>	<i>Liquid</i>
-40°C to 0°C	40% water 40% ethylene glycol 20% alcohol
-20°C to 30°C	50% water 50% ethylene glycol
5°C to 95°C	water, preferably de-ionised with neutral pH
10°C to 150°C	Dow Corning Silicone Oil 200 series *
10°C to 250°C	Dow Corning Silicone Oil 210H/100cs series *

* **Warning:** check gel life at top end of range.

Extraction may be necessary at high temperatures; always check the manufacturer's data and safety sheets before using any of the liquids.

In all cases the OVERTEMPERATURE CUT-OUT must be **set correctly** for the liquid being used and the temperature at which it is to operate

- 10 A bath that is fitted with a lid or insulating ball blanket gives the best operating conditions. A lid or ball blanket will prevent vapour loss, heat loss and give better temperature control. If an open bath is used above 80°C (ie where steam or other readily condensing vapours are present) the operation of the unit, particularly the digital display, may be affected.

Below about 80°C a cover becomes less important but will still give better temperature control.

11 The symbols next to the indicator lamps on the front panel of the thermoregulators have the following meanings:

 : the power indicator

 : the heater indicator

 : the overtemperature indicator

12 Symbols on the switch have the following meanings:

I : mains switch On

O : mains switch Off

Specification

The specification was achieved in an 8 litre bath with a ball blanket according to DIN 58966.

Operating temperature range		-40 to +250°C
Working temperature range		5°C above ambient to 250°C
Temperature selection		Digital
Temperature display		Digital LED
Temperature stability		±0.005°C
Set point accuracy		±1°C
Method of control		3 Term
Temperature sensor		PRT
Nominal heater power	230V	1800W
	120V	1500W
	100V	1250W
Maximum watts density		6.2 W/cm ²
Audible alarm for		Overtemperature
Cooling coil		Accessory
Communications		RS232
Protection against hazards		IP30
Safety device classification		2

The TU-20HT has passed:

EN 50081-1:1992

Electromagnetic Compatibility
emission standard.

EN 50082-1:1992

Electromagnetic Compatibility
immunity standard
(Performance criterion B).



BATHS

Nominal Dimensions

Bath		B-8	B-12	B-18	B-26	B-48
<i>Overall</i>						
Length	A	265 mm	354 mm	530 mm	530 mm	559 mm
Width	B	325 mm	325 mm	325 mm	325 mm	365 mm
Height	C	172 mm	172 mm	172 mm	222 mm	296 mm
<i>Internal</i>						
Maximum Length	D	240 mm	329 mm	505 mm	505 mm	560 mm
Working Length	E	115 mm	205 mm	380 mm	380 mm	435 mm
Width	F	300 mm	300 mm	300 mm	300 mm	330 mm
Max. Working Depth	G	130 mm	130 mm	130 mm	180 mm	255 mm
Min. Working Depth	H	90 mm	90 mm	90 mm	140 mm	215 mm
Maximum Capacity		8 l	12.0 l	18.0 l	26.0 l	48.5 l
Minimum Capacity		6 l	8.4 l	13.2 l	20.5 l	42.5 l

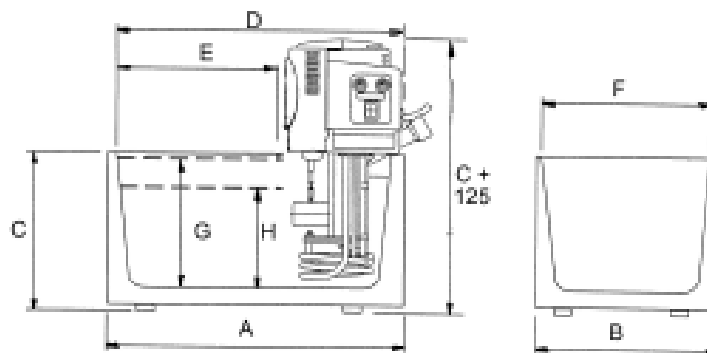
**Working Environment**

The TU-20HT units are designed to work safely under the following conditions:

Ambient temp. range 5°C to 40°C

Humidity Up to 95% relative humidity, non-condensing

Note: The control specifications quoted are for an ambient temperature range of 10°C to 30°C. The specification may deteriorate outside this range but the unit will still work safely.

Radio frequency interference tested and passed to EN50081-1.

Immunity Tested and passed to EN50082-1

OPERATION

- Ensure that both the outlet and return pipes have the blanking caps on.

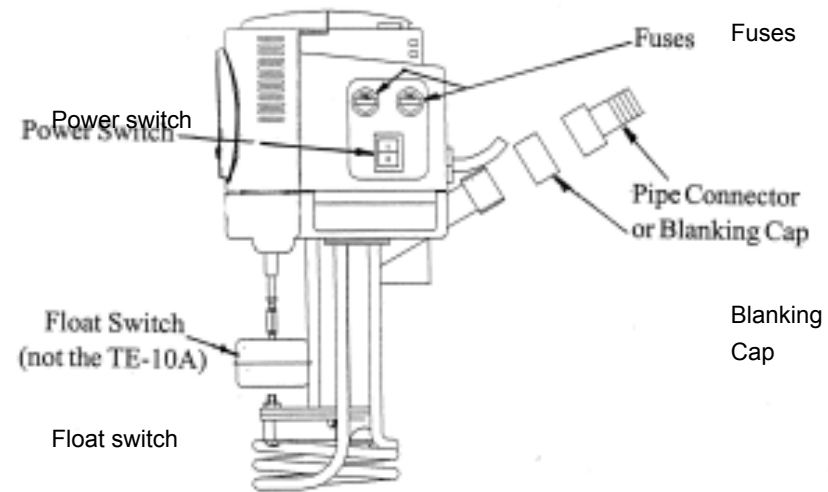

- Switch the unit on by pressing the power switch. The switch and the POWER indicator on the front will light up.

When you Switch On the TU-20HT

When you first switch on, the display will show the edition of the software which your unit uses. For example software issue "5.37" would be shown as follows:

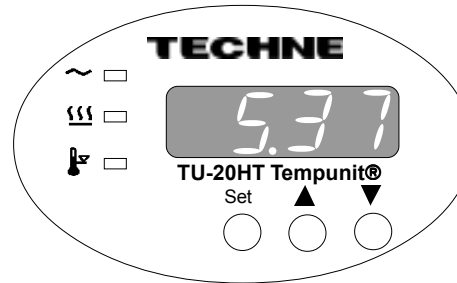

It will display this for 1 second, then the actual temperature of the bath will be indicated.

The Front Panel Controls

The front panel controls consist of three buttons for controlling the display, a four digit LED display and three indicators.

The SET temperature Button

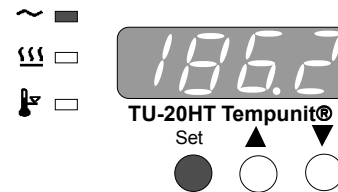

The **SET** temperature button displays the set temperature when pressed.

The UP ARROW Button

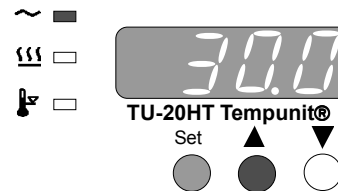

When the **SET** temperature button is held down and the **UP ARROW** button is pressed, the set temperature is increased.

The DOWN ARROW Button

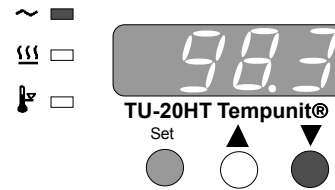

When the **SET** temperature button is held down and the **DOWN ARROW** button is pressed, the set temperature is decreased.

Speed of Change of Set Temperature

Each press of the **UP ARROW** or **DOWN ARROW** buttons will increase or decrease the set temperature by 0.1°C. If the buttons are held down the temperature change will accelerate to 5° per second

Power Indicator

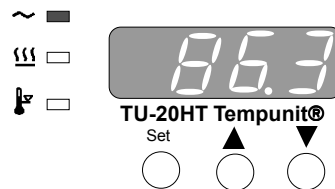

The top indicator shows that there is power to the unit

Heater Indicator

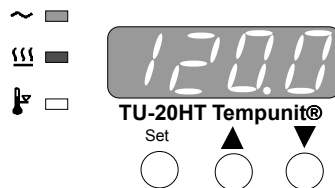

The next indicator shows when the heater is heating. When the temperature is being set, and the new set temperature is higher than the temperature already in the unit, the heater indicator will light as the unit tries to follow the set temperature. If the light is on continuously the heater is getting constant power. The only exception is described under Over-Temperature Indicator. As the temperature approaches the set temperature the heater indicator will flash. When set temperature is reached the indicator will stay on for shorter periods. If the bath temperature is above the set temperature then the indicator will be off, as the heater is not getting any power.

Over-Temperature Indicator

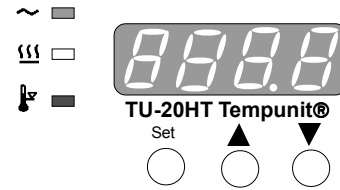

If the unit should, for any reason, exceed the temperature set for the over-temperature cutout, the over-temperature indicator will light. The heater will have been switched off and the unit will begin to cool even if the heater light is on (the light staying on or not depends on which circuit has sensed an over-temperature).

Low Liquid Level

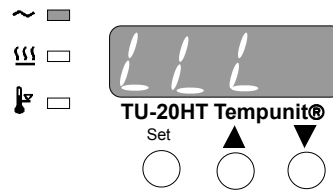

The float switch will trip if the liquid gets below a safe level; the display will change to "LLL". The heater will be switched off. Fill the bath to above the minimum level of 90mm and the display will return to the 'present' temperature; the unit will again work.

Sensor fault Indicator

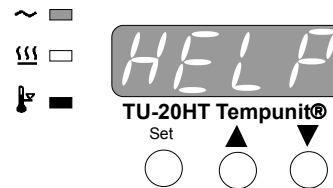

If there should, for any reason, be a sensor fault, the bottom indicator will light. The power to the heater will have been switched off and the unit will begin to return to ambient even if the heater light is on (the light staying on or not depends on which circuit has sensed a fault).

After Use

When you have finished heating samples, remember that parts of the unit and the samples may be very hot. Take the precautions listed earlier. We recommend that the samples should be allowed to cool to 50°C before being removed from the bath. They will still have to be handled with care.

Should you want to remove the unit from the bath, it too should be allowed to cool to 50°C before being removed.

Remember the bridge, the lid (if used), the bath and all other parts close to the bath will be hot while it is in use.

Setting the Overtemperature Cut-out

An adjustable overtemperature cutout is fitted to the TU-20HT. When the cutout operates, the heater will stop working, the audible alarm will sound and the 'Overtemperature cutout indicator' will illuminate. The pump will continue working.

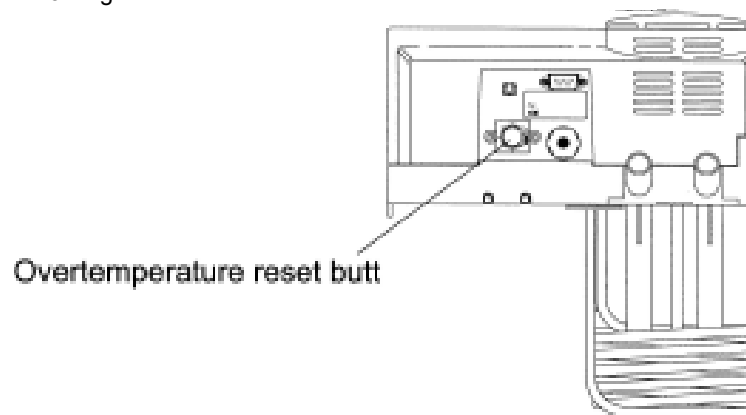

It should be set to approximately 10°C ABOVE THE OPERATING TEMPERATURE. This can be done in one of two ways; '1' is more accurate; '2' is quicker (and better if you do not want to overheat the liquid). For both, first turn the reset button fully clockwise then:

- 1 Heat the bath to the **desired cutout temperature** and turn the reset button anticlockwise until the cutout just trips.

Either: Switch off at the mains power. Remove the unit from the liquid and press the reset button. Return the unit to the liquid, switch on the mains power. The heater will again work.

Or: Allow the liquid to cool, maybe as much as 40°C, and press the reset button. The heater will again work.

- 2 Heat the bath to the required **maximum operating temperature** and turn the reset button anticlockwise until the cutout just trips. Turn the reset button clockwise one small division on the label and press the reset button. The heater will again work.

An alarm will sound when the overtemperature cutout is activated by a temperature higher than that set for the overtemperature cutout. Reset the overtemperature cutout, by pressing the reset button, to stop the alarm.

RS232 SERIAL INTERFACE

The TU-20HT may send data logging information to an IBM PC or compatible computer by connecting the unit and the PC via an RS232 cable, and installing the "Thermsoft" software. Contact your supplier for details.

RS232
Connection

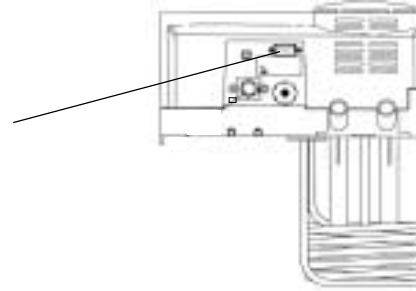

The RS232 cable must be fitted to both the unit and the PC before either unit is powered up, otherwise, data integrity cannot be guaranteed. Once the cable is fitted, it does not matter which unit is powered up first.

The following tables indicate the cable specifications for a 9-way PC serial port:

Thermoregulator		PC	
<i>9-way female D type</i>		<i>9-way female D type</i>	
pin	signal	pin	signal
Case	F.GND	Case	F.GND
3	TxD	3	TxD
2	RxD	2	RxD
7	RTS	7	RTS
8	CTS	8	CTS
6	DSR	6	DSR
1	CD	1	CD
4	DTR	4	DTR
5	S.GND	5	S.GND

Sending data to the PC

The procedure for sending data to the PC is described in the "help" instructions as part of the software. The PC must be properly connected by the RS232 cable and running "Thermsoft" to accept or display data.

ADDITIONAL INFORMATION

NOTE THAT THIS EQUIPMENT SHOULD ONLY BE DISMANTLED BY PROPERLY TRAINED PERSONNEL. **REMOVING THE TOP CASE EXPOSES POTENTIALLY LETHAL MAINS VOLTAGE.** THERE ARE NO OPERATOR MAINTAINABLE PARTS WITHIN THE EQUIPMENT.

In the unlikely event that you experience any problems with your Thermoregulator which cannot easily be remedied, you should contact your supplier and return the unit if necessary. Please include any details of the fault observed and remember to return the unit in its original packing. Techne accept no responsibility for damage to units which are not properly packed for shipping: if in doubt, contact your supplier.

Operator maintenance

1. Cleaning

Before cleaning your unit ALWAYS disconnect from the power supply and allow to cool below 50° C.

Your Thermoregulator can be cleaned by wiping with a damp soapy cloth. Care should be exercised to prevent water from running inside the unit. Do not use abrasive cleaners.

2. Overtemperature cut-out

The overtemperature cut-out is a sensitive mechanical device and mechanical shock can cause it to trip.

- In the event of no heater power, check the mains plug and lead, then reset the cut-out control.
- Repeated operation of the cut-out indicates a serious fault: you may need to return the unit to your supplier for repair.

3. Fuses

Your unit is protected by two fuses.

230V 2 x F10A; 120/100V 2 x T16A

These should only be changed by suitably qualified personnel.

The fuses must only be replaced by a fuse of the same type and value.

If the fuses blow persistently, a serious fault is indicated and you may need to return the unit to your supplier for repair.

Calibration

Remember that if you change the calibration from that set at the factory you may change the calibration at all temperatures. You may get different calibration with different baths and/or liquids.

In order to ensure that the calibration you are setting is correct, you will need to use an independent calibrated probe or thermometer.

Set the temperature display to the particular temperature at which you require to control. Measure the actual temperature of the bath liquid using a calibrated probe or thermometer.

If the calibration is not correct then you can follow this procedure.

- a Hold down the Up and Down buttons and then press the Set button at the same time for 5 seconds.
- b The display will change from the bath temperature to "EEEE".
- c Press the 'SET' button and either the 'UP' or the 'DOWN' button to adjust the display to the same temperature as the measured value.
- d Press 'UP' and 'DOWN' together to confirm the value. The display will return to the bath temperature and the unit will control with the new calibration parameters.

Replacement parts

Each unit is supplied with an O ring for a Thermometer . The following parts may be purchased if replacements or alternatives are required:

<i>Part Number</i>	<i>Description</i>
6007349	O ring (thermometer)
6103913	Cap seal
6103475	Cap

Accessories

There are many accessories both for the thermoregulators and the baths. These are constantly being updated and details can be found in Techne Sales literature. However they do include:

<i>Flat Lids</i>	<i>To fit Bath</i>	<i>Gabled Lids</i>	<i>To fit Bath</i>
FFLAT08	B-8	FGABLE08	B-8
FFLAT12	B-12	FGABLE12	B-12
FFLAT18	B-18 or B-26	FGABLE18	B-18 or B-26
FFLAT48	B-48	FGABLE48	B-48
<i>Bridge</i>		<i>Clamp</i>	
FBRIDGE1	B-8 to B-26 bridge	FCLAMP	TE clamp
FBRIDGE2	B-48 bridge	FCLAMP2	TU clamp
<i>Cooling Coil</i>			
FCC01	Cooling Coil		
<i>Fridge Baths</i>		<i>Dip Coolers</i>	
FRB5D	RB-5A 230V UK	FRU2D	RU-200 230V UK
FRB5E	RB-5A 230V Europe	FRU2E	RU-200 230V Europe
FRB5P	RB-5A 120V	FRU2P	RU-200 120V
FRB2D	RB-12A 230V UK	FRU5D	RU-500 230V UK
FRB2E	RB-12A 230V Europe	FRU5E	RU-500 230V Europe
FRB2P	RB-12A 120V	FRU5P	RU-500 120V
<i>Flow Coolers (not for TU-20HT)</i>			
FFC2D	FC-200 230V UK	Test Tube Racks; and so on.	
FFC2D	FC-200 230V Europe		
FFC2P	FC-200 120V		
FFC5D	FC-500 230V UK		
FFC5D	FC-500 230V Europe		
FFC5P	FC-500 120V		
FTU232	"Thermsoft" kit inc: disc, cable and connector for TU-20HT		

