

Cat. No. W363-E1-2

SYSMAC CQM1H Series

CQM1H-CPU□□ Programmable Controllers

CQM1H-□□□□ Inner Boards

OPERATION MANUAL

OMRON

SYSMAC CQM1H Series

CQM1H-CPU□□ Programmable Controllers

CQM1H-□□□□ Inner Boards

Operation Manual

Revised May 2000

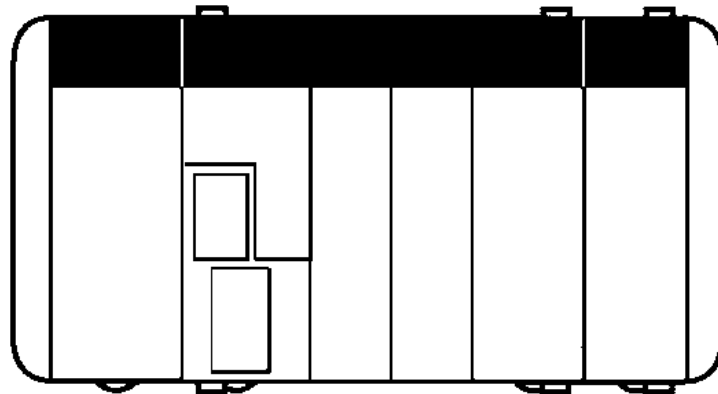



Notice:

OMRON products are manufactured for use according to proper procedures by a qualified operator and only for the purposes described in this manual.

The following conventions are used to indicate and classify precautions in this manual. Always heed the information provided with them. Failure to heed precautions can result in injury to people or damage to property.

 **DANGER** Indicates an imminently hazardous situation which, if not avoided, will result in death or serious injury.

 **WARNING** Indicates a potentially hazardous situation which, if not avoided, could result in death or serious injury.

 **Caution** Indicates a potentially hazardous situation which, if not avoided, may result in minor or moderate injury, or property damage.

OMRON Product References

All OMRON products are capitalized in this manual. The word “Unit” is also capitalized when it refers to an OMRON product, regardless of whether or not it appears in the proper name of the product.

The abbreviation “Ch,” which appears in some displays and on some OMRON products, often means “word” and is abbreviated “Wd” in documentation in this sense.

The abbreviation “PC” means Programmable Controller and is not used as an abbreviation for anything else.

Visual Aids

The following headings appear in the left column of the manual to help you locate different types of information.

Note Indicates information of particular interest for efficient and convenient operation of the product.

1, 2, 3... 1. Indicates lists of one sort or another, such as procedures, checklists, etc.

© OMRON, 1999

All rights reserved. No part of this publication may be reproduced, stored in a retrieval system, or transmitted, in any form, or by any means, mechanical, electronic, photocopying, recording, or otherwise, without the prior written permission of OMRON.

No patent liability is assumed with respect to the use of the information contained herein. Moreover, because OMRON is constantly striving to improve its high-quality products, the information contained in this manual is subject to change without notice. Every precaution has been taken in the preparation of this manual. Nevertheless, OMRON assumes no responsibility for errors or omissions. Neither is any liability assumed for damages resulting from the use of the information contained in this publication.

TABLE OF CONTENTS

PRECAUTIONS	
1 Intended Audience	
2 General Precautions	
3 Safety Precautions	
4 Operating Environment Precautions	
5 Application Precautions	
6 Conformance to EC Directives	
SECTION 1	
Introduction	
1-1 Features	
1-2 System Configuration	
1-3 Expanded System Configuration	
1-4 Functions Listed by Purpose	
1-5 CQM1-CQM1H Comparison	
1-6 Overview Application Procedure	
SECTION 2	
Specifications	
2-1 Unit Specifications	
2-2 Input Unit Specifications	
2-3 Output Unit Specifications	
SECTION 3	
Units	
3-1 CPU Units	
3-2 Power Supply Unit	
3-3 I/O Units	
3-4 Inner Boards	
3-5 Products for Expansion I/O Blocks	
3-6 Programming Devices	
SECTION 4	
Installation	
4-1 Fail-safe Circuits	
4-2 Installation Precautions	
4-3 Mounting Dimensions	
4-4 Connecting PC Components	
4-5 Inner Board Installation	
4-6 DIN Track Installation	
4-7 Wiring and Connections	
4-8 I/O Unit Wiring Precautions	
4-9 Connecting Programming Devices	
4-10 Connecting Programmable Terminals	
SECTION 5	
Overview of Operation	
5-1 Internal Structure of CPU Unit	
5-2 Operating Modes	
SECTION 6	
Switch Settings	
6-1 DIP Switch Settings	
6-2 Communications Port and Startup Modes Settings	

TABLE OF CONTENTS

SECTION 7

Using a Programming Console

- 7-1 Programming
- 7-2 Connecting the Programming Console
- 7-3 Programming Console Operations
- 7-4 Programming Example

SECTION 8

Inner Boards

- 8-1 High-speed Counter Board
- 8-2 Pulse I/O Board
- 8-3 Absolute Encoder Interface Board
- 8-4 Analog Setting Board
- 8-5 Analog I/O Board
- 8-6 Serial Communications Board

SECTION 9

Battery Maintenance

- 9-1 Battery Replacement
- 9-2 Battery Life
- 9-3 Replacement Procedure

Appendices

- A Preparing Cables for Inner Boards

Glossary

Index

Revision History

About this Manual:

The CQM1H is a compact, high-speed Programmable Controller (PC) designed for advanced control operations in systems requiring from 16 to 256 I/O points per PC. There are two manuals describing the setup and operation of the CQM1H: The *CQM1H Operation Manual* (this manual) and the *CQM1H Programming Manual*. Also available is the *CQM1-series Dedicated I/O Units Operation Manual*.

This manual describes the system configuration and installation of the CQM1H and provides a basic explanation of operating procedures for the Programming Consoles. It also introduces the capabilities of the SYSMAC Support Software (SSS) and SYSMAC-CPT Support Software. Read this manual first to acquaint yourself with the CQM1H.

The *CQM1H Programming Manual* (W364) provides detailed descriptions of the CQM1H's programming functions. The *SYSMAC Support Software Operation Manuals: Basics and C-series PCs* (W247 and W248) provide descriptions of SSS operations for the CQM1H and other SYSMAC C-series PCs. The *SYSMAC-CPT Support Software Quick Start Guide* (W332) and *User Manual* (W333) provide descriptions of ladder diagram operation in the Windows environment. The *CX-Programmer User Manual* (W361) and the *CX-Server User Manual* (W362) provide details of operations for the WS02-CXPC1-E CX-Programmer.

Please read this manual carefully and be sure you understand the information provided before attempting to install and operate the CQM1H.

Section 1 describes the CQM1H's special features and functions, describes the system configurations, and outlines the steps required before operation. It also provides a list of CQM1H functions by purpose and a comparison between the CQM1H and the CQM1.

Section 2 gives specifications for the Units that go together to create a CQM1H PC and provides functional specifications of the memory areas.

Section 3 provides details on functions and nomenclature for the Units that make up the CQM1H and provides information on Programming Devices and communications specifications.

Section 4 describes how to install the CQM1H PC, including how to mount Units, wire I/O, and connect Programming Devices. Installation precautions and mounting dimensions are also provided. Follow the instructions carefully to ensure proper operation. Improper installation can cause the PC to malfunction.

Section 5 gives a general overview of CQM1H operation and includes details on the internal structure of the CPU Unit and describes the different operating modes.

Section 6 describes the setting on the DIP switch on the front of the CPU Unit. Most PC operations are controlled by parameters set in the PC Setup. Refer to the *CQM1H Programming Manual* for information on the PC Setup.

Section 7 provides information on connecting and using a Programming Console. Refer to 7-4-2 Programming Console Error Messages for details on errors that might occur during Programming Console operations.

Section 8 describes hardware information for the following Inner Boards: Serial Communications Board, High-speed Counter Board, Pulse I/O Board, Absolute Encoder Interface Board, Analog Setting Board, and Analog I/O Board. Refer to the *CQM1H Programming Manual* for information on software application.

Section 9 describes the maintenance of the battery that backs up memory in the CPU Unit, including the replacement procedure.

The Appendix describes preparing cables for Inner Boards.

WARNING

Failure to read and understand the information provided in this manual may result in personal injury or death, damage to the product, or product failure. Please read each section in its entirety and be sure you understand the information provided in the section and related sections before attempting any of the procedures or operations given.

PRECAUTIONS

This section provides general precautions for using the CQM1H-series Programmable Controllers (PCs) and related devices.

The information contained in this section is important for the safe and reliable application of Programmable Controllers. You must read this section and understand the information contained before attempting to set up or operate a PC system.

- 1 Intended Audience
- 2 General Precautions
- 3 Safety Precautions
- 4 Operating Environment Precautions
- 5 Application Precautions
- 6 Conformance to EC Directives
- 6-1 Applicable Directives
- 6-2 Concepts
- 6-3 Conformance to EC Directives
- 6-4 Relay Output Noise Reduction Methods

1 Intended Audience

This manual is intended for the following personnel, who must also have knowledge of electrical systems (an electrical engineer or the equivalent).

- Personnel in charge of installing FA systems.
- Personnel in charge of designing FA systems.
- Personnel in charge of managing FA systems and facilities.

2 General Precautions

The user must operate the product according to the performance specifications described in the operation manuals.

Before using the product under conditions which are not described in the manual or applying the product to nuclear control systems, railroad systems, aviation systems, vehicles, combustion systems, medical equipment, amusement machines, safety equipment, and other systems, machines, and equipment that may have a serious influence on lives and property if used improperly, consult your OMRON representative.

Make sure that the ratings and performance characteristics of the product are sufficient for the systems, machines, and equipment, and be sure to provide the systems, machines, and equipment with double safety mechanisms.

This manual provides information for programming and operating the PC. Be sure to read this manual before attempting to use the PC and keep this manual close at hand for reference during operation.

 **WARNING** It is extremely important that a PC and all PC Units be used for the specified purpose and under the specified conditions, especially in applications that can directly or indirectly affect human life. You must consult with your OMRON representative before applying a PC System to the above-mentioned applications.

3 Safety Precautions

 **WARNING** The CPU Unit refreshes I/O even when the program is stopped (i.e., even in PROGRAM mode). Confirm safety thoroughly in advance before changing the status of any part of memory allocated to I/O Units, Dedicated I/O Units, or Inner Board. Any changes to the data allocated to any Unit may result in unexpected operation of the loads connected to the Unit. Any of the following operation may result in changes to memory status.

- Transferring I/O memory data to the CPU Unit from a Programming Device.
- Changing present values in memory from a Programming Device.
- Force-setting/-resetting bits from a Programming Device.
- Transferring I/O memory from a host computer or from another PC on a network.

 **WARNING** Do not attempt to take any Unit apart or touch the interior while the power is being supplied. Doing so may result in electric shock.

 **WARNING** Do not touch any of the terminals or terminal blocks while the power is being supplied. Doing so may result in electric shock.

 **WARNING** Provide safety measures in external circuits (i.e., not in the Programmable Controller), including the following items, in order to ensure safety in the system if an abnormality occurs due to malfunction of the PC or another external factor affecting the PC operation. Not doing so may result in serious accidents.

- Emergency stop circuits, interlock circuits, limit circuits, and similar safety measures must be provided in external control circuits.
- The PC will turn OFF all outputs when its self-diagnosis function detects any error or when a severe failure alarm (FALS) instruction is executed. As a countermeasure for such errors, external safety measures must be provided to ensure safety in the system.
- The PC outputs may remain ON or OFF due to deposition or burning of the output relays or destruction of the output transistors. As a countermeasure for such problems, external safety measures must be provided to ensure safety in the system.
- When the 24-VDC output (service power supply to the PC) is overloaded or short-circuited, the voltage may drop and result in the outputs being turned OFF. As a countermeasure for such problems, external safety measures must be provided to ensure safety in the system.

 **WARNING** Do not attempt to disassemble, repair, or modify any Units. Any attempt to do so may result in malfunction, fire, or electric shock.



 **WARNING** Do not touch the Power Supply Unit while power is being supplied or immediately after power has been turned OFF. Doing so may result in burns.

 **Caution** Execute online edit only after confirming that no adverse effects will be caused by extending the cycle time. Otherwise, the input signals may not be readable.

 **Caution** Confirm safety at the destination node before transferring a program to another node or changing contents of the I/O memory area. Doing either of these without confirming safety may result in injury.



 **Caution** Tighten the screws on the terminal block of the AC Power Supply Unit to the torque specified in the operation manual. The loose screws may result in burning or malfunction.

4 Operating Environment Precautions

-  **Caution** Do not operate the control system in the following locations:
- Locations subject to direct sunlight.
 - Locations subject to temperatures or humidity outside the range specified in the specifications.
 - Locations subject to condensation as the result of severe changes in temperature.
 - Locations subject to corrosive or flammable gases.
 - Locations subject to dust (especially iron dust) or salts.
 - Locations subject to exposure to water, oil, or chemicals.
 - Locations subject to shock or vibration.
-  **Caution** Take appropriate and sufficient countermeasures when installing systems in the following locations:
- Locations subject to static electricity or other forms of noise.
 - Locations subject to strong electromagnetic fields.
 - Locations subject to possible exposure to radioactivity.
 - Locations close to power supplies.
-  **Caution** The operating environment of the PC System can have a large effect on the longevity and reliability of the system. Improper operating environments can lead to malfunction, failure, and other unforeseeable problems with the PC System. Be sure that the operating environment is within the specified conditions at installation and remains within the specified conditions during the life of the system.

5 Application Precautions

Observe the following precautions when using the PC System.

-  **WARNING** Always heed these precautions. Failure to observe the following precautions could lead to serious or possibly fatal injury.
- Always ground the system to 100 Ω or less when installing the Units. Not connecting to a ground of 100 Ω or less may result in electric shock.
 - Always turn OFF the power supply to the PC before attempting any of the following. Not turning OFF the power supply may result in malfunction or electric shock.
 - Assembling the Units.
 - Connecting cables or wiring the system.
 - Connecting or disconnecting the connectors.
 - Setting DIP switches.
 - Replacing the battery.
-  **Caution** Failure to observe the following precautions could lead to faulty operation of the PC or the system, or could damage the PC or PC Units. Always heed these precautions.
- Fail-safe measures must be taken by the customer to ensure safety in the event of incorrect, missing, or abnormal signals caused by broken signal lines, momentary power interruptions, or other causes.

- Fail-safe measures must be taken by the customer to ensure safety in the event that outputs from Output Units remain ON as a result of internal circuit failures, which can occur in relays, transistors, and other elements.
- Always turn ON power to the PC before turning ON power to the control system. If the PC power supply is turned ON after the control power supply, temporary errors may result in control system signals because the output terminals on DC Output Units and other Units will momentarily turn ON when power is turned ON to the PC.
- Do not turn OFF the power supply to the PC when data is being transferred. In particular, do not turn OFF the power supply when reading or writing a Memory Card. Also, do not remove the Memory Card when the BUSY indicator is lit. To remove a Memory Card, first press the memory card power supply switch and then wait for the BUSY indicator to go out before removing the Memory Card.
- If the I/O Hold Bit (SR 25212) is turned ON, the outputs from the PC will not be turned OFF and will maintain their previous status when the PC is switched from RUN or MONITOR mode to PROGRAM mode. Make sure that the external loads will not produce dangerous conditions when this occurs. (When operation stops for a fatal error, including those produced with the FALS(07) instruction, all outputs from Output Unit will be turned OFF and only the internal output status will be maintained.)
- Install the Units properly as specified in the operation manuals. Improper installation of the Units may result in malfunction.
- Mount Units only after checking terminal blocks and connectors completely.
- When assembling the Units or mounting the end cover, be sure to lock them securely as shown in the following illustrations. If they are not properly locked, desired functionality may not be achieved.
- Be sure to mount the end cover to the rightmost Unit.
- Be sure that all the mounting screws, terminal screws, and cable connector screws are tightened to the torque specified in the relevant manuals. Incorrect tightening torque may result in malfunction.
- Be sure that the terminal blocks, Memory Units, expansion I/O cables, and other items with locking devices are properly locked into place. Improper locking may result in malfunction.
- Be sure to confirm the orientation and polarities when connecting terminal blocks and connectors.
- Leave the label attached to the Unit when wiring. Removing the label may result in malfunction if foreign matter enters the Unit.
- Remove the label after the completion of wiring to ensure proper heat dissipation. Leaving the label attached may result in malfunction.
- Wire all connections correctly.
- When supplying power at 200 to 240 V AC from a CQM1-PA216 Power Supply Unit, always remove the metal jumper from the voltage selector terminals. The product will be destroyed if 200 to 240 V AC is supplied while the metal jumper is attached.
- A ground of 100 Ω or less must be installed when shorting the GR and LG terminals on the Power Supply Unit.
- Use crimp terminals for wiring. Do not connect bare stranded wires directly to terminals. Connection of bare stranded wires may result in burning.
- Do not apply voltages to the Input Units in excess of the rated input voltage. Excess voltages may result in burning.
- Do not apply voltages or connect loads to the Output Units in excess of the maximum switching capacity. Excess voltage or loads may result in burning.

- Install external breakers and take other safety measures against short-circuiting in external wiring. Insufficient safety measures against short-circuiting may result in burning.
- Always use the power supply voltages specified in the operation manuals. An incorrect voltage may result in malfunction or burning.
- Take appropriate measures to ensure that the specified power with the rated voltage and frequency is supplied. Be particularly careful in places where the power supply is unstable. An incorrect power supply may result in malfunction.
- Disconnect the functional ground terminal when performing withstand voltage tests. Not disconnecting the functional ground terminal may result in burning.
- Check switch settings, the contents of the DM Area, and other preparations before starting operation. Starting operation without the proper settings or data may result in an unexpected operation.
- Check the user program for proper execution before actually running it on the Unit. Not checking the program may result in an unexpected operation.
- Double-check all wiring and switch settings before turning ON the power supply. Incorrect wiring may result in burning.
- Confirm that no adverse effect will occur in the system before attempting any of the following. Not doing so may result in an unexpected operation.
 - Changing the operating mode of the PC.
 - Force-setting/force-resetting any bit in memory.
 - Changing the present value of any word or any set value in memory.
- Before touching a Unit, be sure to first touch a grounded metallic object in order to discharge any static build-up. Not doing so may result in malfunction or damage.
- Do not pull on the cables or bend the cables beyond their natural limit. Doing either of these may break the cables.
- Do not place objects on top of the cables or other wiring lines. Doing so may break the cables.
- Resume operation only after transferring to the new CPU Unit the contents of the DM Area, HR Area, and other data required for resuming operation. Not doing so may result in an unexpected operation.
- Do not short the battery terminals or charge, disassemble, heat, or incinerate the battery. Do not subject the battery to strong shocks. Doing any of these may result in leakage, rupture, heat generation, or ignition of the battery. Dispose of any battery that has been dropped on the floor or otherwise subjected to excessive shock. Batteries that have been subjected to shock may leak if they are used.
- UL standards required that batteries be replaced only by experienced technicians. Do not allow unqualified persons to replace batteries.
- When replacing parts, be sure to confirm that the rating of a new part is correct. Not doing so may result in malfunction or burning.
- When transporting or storing circuit boards, cover them in antistatic material to protect them from static electricity and maintain the proper storage temperature.
- Do not touch circuit boards or the components mounted to them with your bare hands. There are sharp leads and other parts on the boards that may cause injury if handled improperly.
- Before touching a Unit or Board, be sure to first touch a grounded metallic object to discharge any static build-up from your body. Not doing so may result in malfunction or damage.
- Provide sufficient clearances around the Unit and other devices to ensure proper heat dissipation. Do not cover the ventilation openings of the Unit.

- For wiring, use crimp terminals of the appropriate size as specified in relevant manuals.
- Do not allow metallic objects or conductive wires to enter the Unit.
- Set the operating settings of the Temperature Controller properly according to the system to be controlled.
- Provide appropriate safety measures, such as overheat prevention and alarm systems, in separate circuits to ensure safety of the entire system even when the Temperature Controller malfunctions.
- Allow at least 10 minutes after turning ON the Temperature Controller as warm-up time.
- Do not use thinner to clean the product. Use commercially available cleaning alcohol.
- Mount the I/O Control Unit on the right of the CPU Block.
- When using Expansion I/O Blocks, configure the system so that the current consumptions for the CPU Block and each of the Expansion I/O Blocks do not exceed the specified values, and that the total current consumption does not exceed the current capacity of the Power Supply Unit.
- Configure the system so that the number of Units in both the CPU Block and Expansion I/O Blocks do not exceed the maximum number of connectable Units for the Block.

6 Conformance to EC Directives

6-1 Applicable Directives

- EMC Directives
- Low Voltage Directive

6-2 Concepts

EMC Directives

OMRON devices that comply with EC Directives also conform to the related EMC standards so that they can be more easily built into other devices or machines. The actual products have been checked for conformity to EMC standards (see the following note). Whether the products conform to the standards in the system used by the customer, however, must be checked by the customer.

EMC-related performance of the OMRON devices that comply with EC Directives will vary depending on the configuration, wiring, and other conditions of the equipment or control panel in which the OMRON devices are installed. The customer must, therefore, perform final checks to confirm that devices and the overall machine conform to EMC standards.

Note Applicable EMC (Electromagnetic Compatibility) standards are as follows:

EMS (Electromagnetic Susceptibility): EN61131-2

EMI (Electromagnetic Interference): EN50081-2

(Radiated emission: 10-m regulations)

Low Voltage Directive

Always ensure that devices operating at voltages of 50 to 1,000 V AC or 75 to 1,500 V DC meet the required safety standards for the PC (EN61131-2).

6-3 Conformance to EC Directives

The CQM1H-series PCs comply with EC Directives. To ensure that the machine or device in which a CQM1H-series PC is used complies with EC directives, the PC must be installed as follows:

- 1, 2, 3...**
1. The PC must be installed within a control panel.
 2. Reinforced insulation or double insulation must be used for the DC power supplies used for the communications and I/O power supplies.
 3. PCs complying with EC Directives also conform to the Common Emission Standard (EN50081-2). When a PC is built into a machine, however, noise can be generated by switching devices using relay outputs and cause the overall machine to fail to meet the Standards. If this occurs, surge killers must be connected or other measures taken external to the PC.

The following methods represent typical methods for reducing noise, and may not be sufficient in all cases. Required countermeasures will vary depending on the devices connected to the control panel, wiring, the configuration of the system, and other conditions.

6-4 Relay Output Noise Reduction Methods

The CQM1H-series PCs conforms to the Common Emission Standards (EN50081-2) of the EMC Directives. However, noise generated by relay output switching may not satisfy these Standards. In such a case, a noise filter must be connected to the load side or other appropriate countermeasures must be provided external to the PC.

Countermeasures taken to satisfy the standards vary depending on the devices on the load side, wiring, configuration of machines, etc. Following are examples of countermeasures for reducing the generated noise.

Countermeasures

Refer to EN50081-2 for more details.

Countermeasures are not required if the frequency of load switching for the whole system including the PC is less than 5 times per minute.

Countermeasures are required if the frequency of load switching for the whole system including the PC is 5 times or more per minute.

Countermeasure Examples

When switching an inductive load, connect a surge protector, diodes, etc., in parallel with the load or contact as shown below.

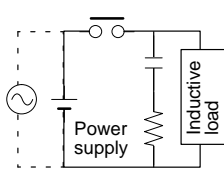
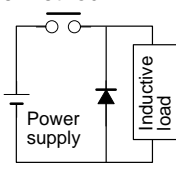
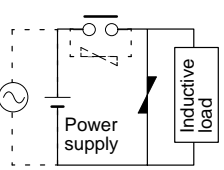
Circuit	Current		Characteristic	Required element
	AC	DC		
<p>CR method</p> 	Yes	Yes	<p>If the load is a relay or solenoid, there is a time lag between the moment the circuit is opened and the moment the load is reset.</p> <p>If the supply voltage is 24 or 48 V, insert the surge protector in parallel with the load. If the supply voltage is 100 to 200 V, insert the surge protector between the contacts.</p>	<p>The capacitance of the capacitor must be 1 to 0.5 μF per contact current of 1 A and resistance of the resistor must be 0.5 to 1 Ω per contact voltage of 1 V. These values, however, vary with the load and the characteristics of the relay. Decide these values from testing, and take into consideration that the capacitance suppresses spark discharge when the contacts are separated and the resistance limits the current that flows into the load when the circuit is closed again.</p> <p>The dielectric strength of the capacitor must be 200 to 300 V. If the circuit is an AC circuit, use a capacitor with no polarity.</p>
<p>Diode method</p> 	No	Yes	<p>The diode connected in parallel with the load changes energy accumulated by the coil into a current, which then flows into the coil so that the current will be converted into Joule heat by the resistance of the inductive load.</p> <p>This time lag, between the moment the circuit is opened and the moment the load is reset, caused by this method is longer than that caused by the CR method.</p>	<p>The reversed dielectric strength value of the diode must be at least 10 times as large as the circuit voltage value. The forward current of the diode must be the same as or larger than the load current.</p> <p>The reversed dielectric strength value of the diode may be two to three times larger than the supply voltage if the surge protector is applied to electronic circuits with low circuit voltages.</p>
<p>Varistor method</p> 	Yes	Yes	<p>The varistor method prevents the imposition of high voltage between the contacts by using the constant voltage characteristic of the varistor. There is time lag between the moment the circuit is opened and the moment the load is reset.</p> <p>If the supply voltage is 24 or 48 V, insert the varistor in parallel with the load. If the supply voltage is 100 to 200 V, insert the varistor between the contacts.</p>	---

When switching a load with a high inrush current such as an incandescent lamp, suppress the inrush current as shown below.

Countermeasure 1

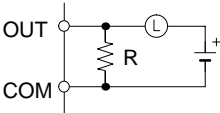

Providing a dark current of approx. one-third of the rated value through an incandescent lamp

Countermeasure 2

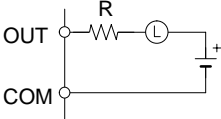

Providing a limiting resistor

SECTION 1

Introduction

This section describes the CQM1H's special features and functions, describes the system configurations, and outlines the steps required before operation. It also provides a list of CQM1H functions by purpose and a comparison between the CQM1H and the CQM1. Read this section first if you have not previously used the CQM1H.

Refer to the *CQM1H Programming Manual* for information on programming.

1-1	Features	
1-2	System Configuration	
1-2-1	Basic Configuration	
1-2-2	Connections to Programming Devices	
1-2-3	CPU Units	
1-2-4	Inner Boards	
1-2-5	Communications Units	
1-2-6	Memory Cassettes	
1-2-7	Power Supply Units	
1-2-8	Products for Expansion I/O Blocks	
1-2-9	I/O Units	
1-2-10	Dedicated I/O Units	
1-2-11	Accessories	
1-2-12	Maximum Number of I/O Units and I/O Points	
1-3	Expanded System Configuration	
1-3-1	Serial Communications System	
1-3-2	Communications Networks	
1-4	Functions Listed by Purpose	
1-4-1	High-speed Counters	
1-4-2	Pulse Outputs	
1-5	CQM1-CQM1H Comparison	
1-6	Overview Application Procedure	

1-1 Features

The CQM1H is a compact Programmable Controller (PC) that supports communications and other advanced functions. It is a package-type PC that is mounted to DIN Track to control small to medium-size machines.

A flexible system configuration is enhanced by serial communications with a protocol macro function, user-installed boards called Inner Boards, network communications, a wide range of monitoring and setting methods, higher speed, and larger capacity. These features enable added-value machine control.

- Mount up to two Inner Boards to add communications or control functions.
 Communications Functions: Serial Communications Board
 Control Functions: High-speed Counter Board, Pulse I/O Board, Absolute Encoder Interface Board, Analog Setting Board, and Analog I/O Board
- Mount a Controller Link Unit to connect to a Controller Link Network.
- Connect simultaneously to both a Programming Device and a Programmable Terminal (PT).
- Obtain higher speed and capacity in comparison to the CQM1: 1.25 times faster, twice the program capacity (15.2 Kwords), twice the I/O capacity (512 points), and twice the data memory capacity (12 Kwords).
- Use new instructions.
- Maintain compatibility with previous models of PC.

Flexible System Configuration

The CQM1H does not require a Backplane and is constructed by connecting Units via connectors on the sides of the Units, allowing flexible system configuration. The CPU Unit contains 16 built-in DC input points. Two Inner Boards can be mounted in the CPU Unit. One Controller Link Unit (a Communications Unit) and a combined maximum of eleven I/O Units and Dedicated I/O Units can also be connected. If an Expansion I/O Block is used, a maximum of 16 Units can be connected. (See 1-2-1 Basic Configuration.)

- Note**
1. The CQM1H is mounted to DIN Track.
 2. Only the CQM1H-CPU51/61 CPU Units support Inner Boards and the Controller Link Unit.

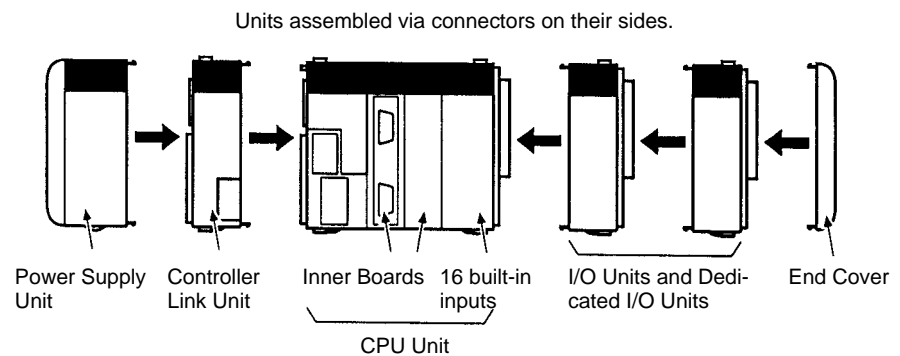

Higher Speeds and Greater Capacity

Execution times have been reduced to 0.375 μ s for the LOAD instruction (from 0.50 μ s for the CQM1), to 17.7 μ s for the MOVE instruction (from 23.5 μ s) and to 0.70 ms for overseeing (from 0.80 ms), reducing the total cycle time by approximately 25%.

- The program capacity, the I/O capacity, and the data memory capacity have all been approximately doubled. The program capacity has been increased to 15.2 Kwords (from 7.2 Kwords for the CQM1); the I/O capacity, to 512 points (from 256 points); and the data memory capacity, to 6 Kwords of DM and 6 Kwords of EM (from 6 Kwords of DM only).

- A 16-Kword Memory Cassette can be mounted in the CQM1H to handle large user programs or more data. These features ensure a higher level of machine control and greater ease of use.

Increased Functionality with Inner Boards

The CQM1H features Inner Boards that allow serial communications, multi-point high-speed counter (rotary encoder) inputs, simple positioning (trapezoidal acceleration/deceleration pulse outputs), speed changes, PWM (variable duty-factor pulse) outputs, absolute rotary encoder inputs, analog I/O (4 inputs, 2 outputs), and analog settings.

A Serial Communications Board, High-speed Counter Board, Pulse I/O Board, Absolute Encoder Interface Board, Analog I/O Board, and Analog Setting Board are available. These Inner Boards can be combined, mounted and used as required for the machine being controlled. (There are mounting restrictions for some of the Inner Boards.)

Note The CPU Unit also provides 16 built-in inputs, as well as high-speed counter and input interrupt functions. Pulse outputs are also supported using a standard Transistor Output Unit.

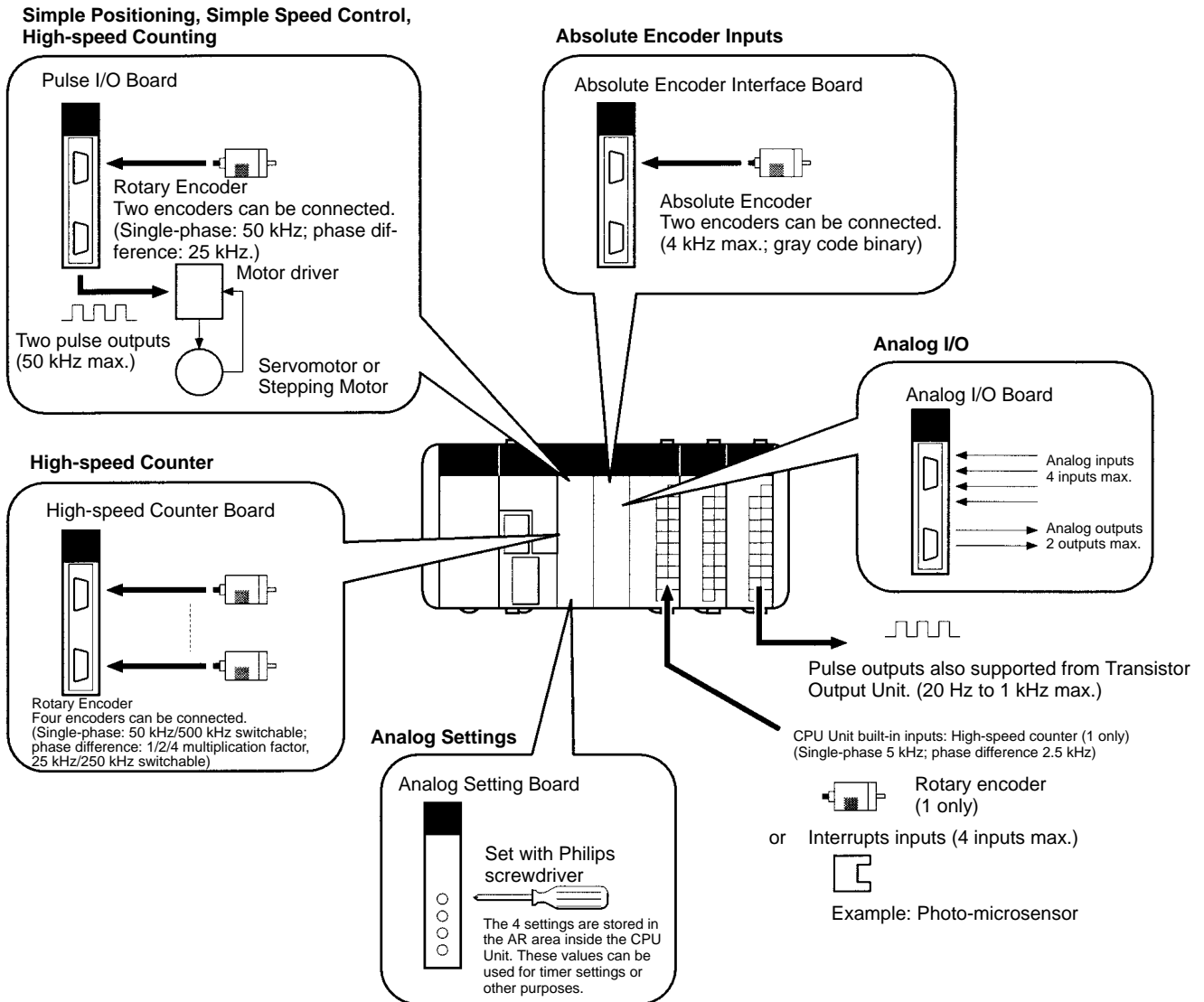

Better Connections to Machine Components with Serial Communications

Connections can be easily made to general-purpose machine components and dedicated controllers. The Serial Communications Board (an Inner Board) supports a protocol macro function. You can create macros for protocols according

to the communications specifications of the external device, allowing data transfers with general-purpose devices to be executed with a single PMCR instruction. Essentially any device with a serial port can be communicated with, such as temperature controllers, bar-code readers, and dedicated numeric controllers.

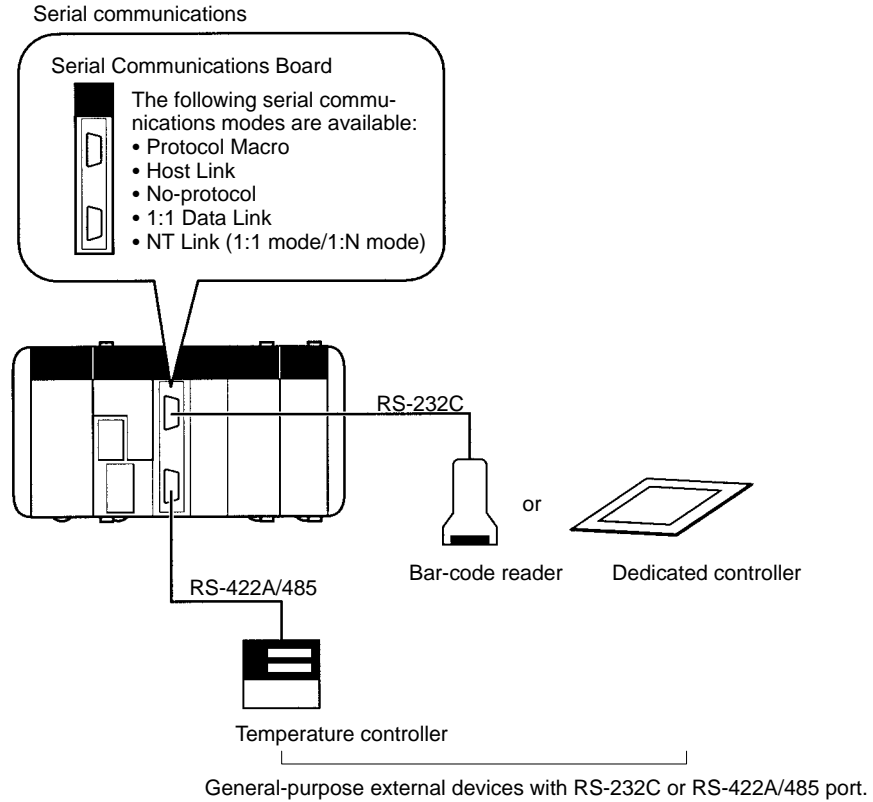

Distributed Control with Compact PCs with Network Communications

A Controller Link Unit can be included in the CQM1H. Data can be exchanged between several PCs using a Controller Link Network. Data links are supported to create shared data areas and message communications are supported to enable sending required data and commands using network communications instructions. The Controller Link Network can be easily constructed using twisted-pair cable. Data exchange is also supported with C200HX/HG/HE, CS1, CVM1, and CV-series PCs, as well as with personal computers.

Note Data links can be created with another CQM1H or with a CQM1, CPM1, CPM1A, CPM2A, CPM2C, SRM1, C200HX/HG/HE, or C200HS simply by making a 1:1 connection between the built-in RS-232C ports in the CPU Units.

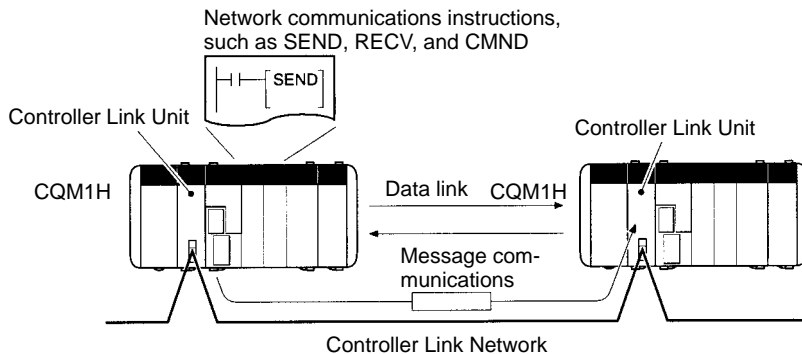

Baud rate: 2 Mbps; transmission distance: 1 km (when baud rate is 500 kbps); max. No. of nodes: 32.
 A maximum of 8,000 words per node can be sent for the CQM1H.
 Data exchange supported for CQM1, CQM1H, CS1, C200HX/HG/HE, and CVM1/CV-series PCs.

**High-speed/
Long-distance
Communications with
CompoBus/S**

A CompoBus/S Master Unit can be included in the CQM1H. High-speed or long-distance remote I/O communications can be performed with CompoBus/S Slaves. (The CompoBus/S Master Unit is a Dedicated I/O Unit for the CQM1H.)

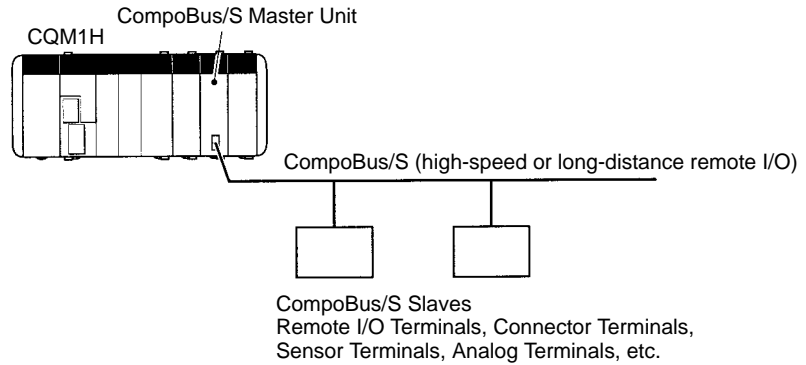

**A Wide Range of HMI
Monitoring and Setting
Methods**

Programming Devices and Programmable Terminals (PTs) can be connected to up to four ports, two ports on the CPU Unit and two ports on a Serial Communications Board. It is thus possible to set up and monitor machine control from a PT while monitoring or programming from a Programming Console or a personal computer.

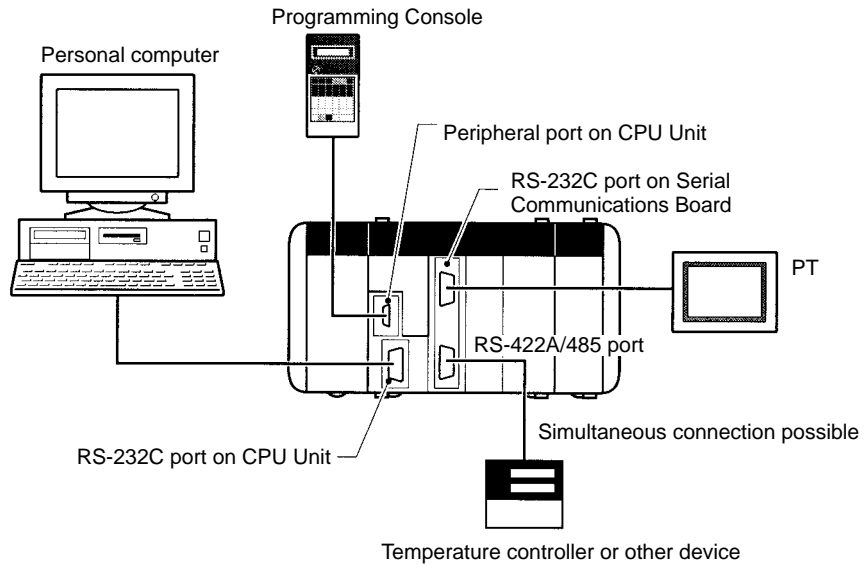

You can also program and monitor from a personal computer at a remote location via a modem. When used in combination with the protocol macro function, it is also possible to call the personal computer from the CQM1H using the PMCR(—) instruction, and when the connection is made, switch the serial communications mode to Host Link (for remote programming/monitoring) using the STUP(—) instruction.

If an Analog Setting Board is mounted, fine adjustments of settings, such as rotational speed or timer settings, are possible on-site using the adjustments on the front of the Board.

The ON/OFF status of a user-programmable DIP switch pin is stored in the AR area. The setting of this pin can be used on-site to switch between trial operation and actual operation, to switch set values, or to perform any other function that can be programmed in response to the changes in status of the AR bit corresponding to this DIP switch pin.

Easier Programming with a Complete Instruction Set and Interrupt Functions

Math instructions (such as floating-point math, exponential functions, logarithmic functions, and trigonometric functions), a TOTALIZING TIMER (TTIM(—)) instruction, a CHANGE RS-232C SETUP (STUP(—)) instruction, and network communications instructions have been added. In addition, complete interrupt functions for the CPU Unit are supported, including input interrupts, high-speed counter interrupts, and interval timer interrupts (with scheduled interrupts and one-shot interrupts). Interrupts from serial communications using a protocol macro (interrupt notification) are also supported. These interrupts enable easier and more flexible machine control.

Memory Cassettes for Program/Data Management; Clock Included

A Memory Cassette (EEPROM or flash memory) can be mounted in the front of the CPU Unit. User programs, data memory (read-only DM, PC Setup) and expansion instruction information can be saved and read in batch. It is also possible to make settings so that data contained in the Memory Cassette is loaded automatically at startup. This feature means that, in the event of battery expiration or careless programming/monitoring operations, data for user programs and data memory is not lost. It also means that changes in user programs required for different controlled machines can be made easily. Further, by using a Memory Cassette with a clock, times and dates can be used in the user program.

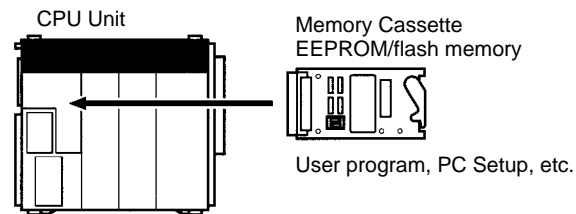

Compatibility with CQM1 Units

The Power Supply Units, Basic I/O Units, and Dedicated I/O Units for the CQM1 can be used in the CQM1H. Consequently, Dedicated I/O Units like Temperature Control Units, Sensor Units, B7A Interface Units, and CompoBus/D (DeviceNet) Link Units can all be used. In addition, user programs used on the CQM1, Programming Consoles for the CQM1 and conventional Memory Cassettes can also be used. (A conversion adapter is necessary to use the Programming Console.)

1-2 System Configuration

1-2-1 Basic Configuration

The PC configuration depends on the model of CPU Unit being used and on whether or not an Expansion I/O Block is connected. Examples are shown below.

CQM1H-CPU51/61

Up to two Inner Boards can be mounted and one Communications Unit can be connected with the CQM1H-CPU51 or CQM1H-CPU61 CPU Unit. The configuration is shown below.

CPU Block Only

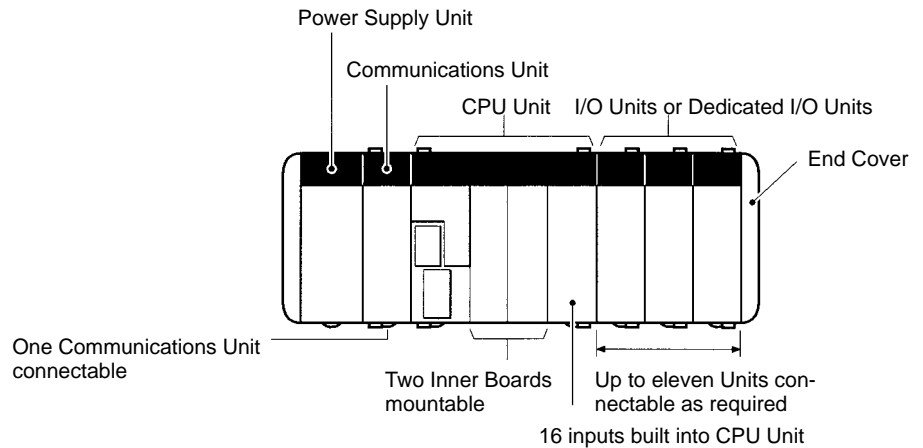

CPU Block and Expansion I/O Block

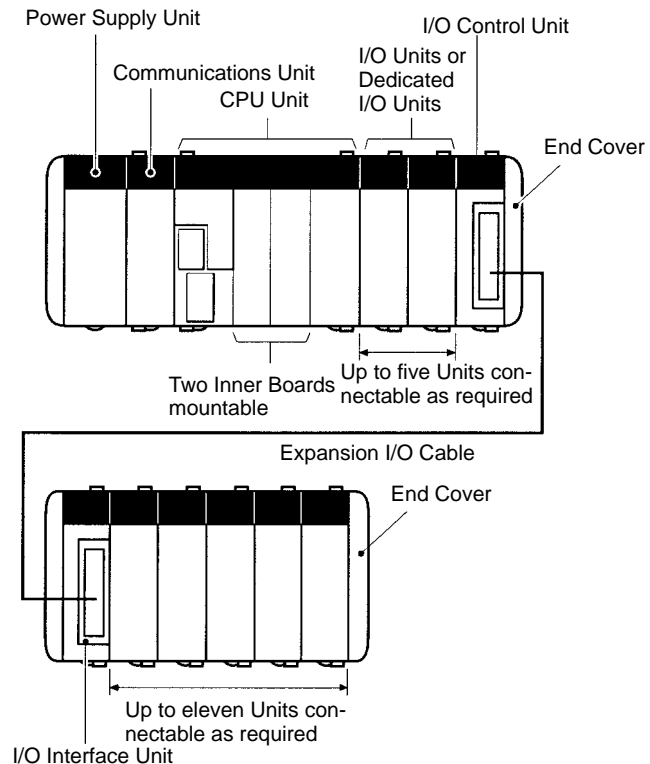

CQM1H-CPU11/21

The CQM1H-CPU11 and CQM1H-CPU21 CPU Units do not support Inner Boards or Communications Units. The configuration is shown below.

CPU Block Only

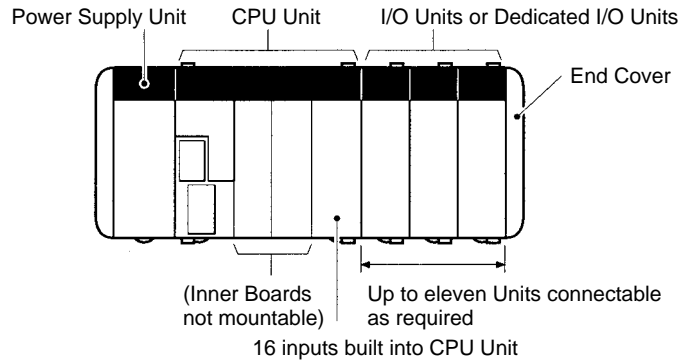

CPU Block and Expansion I/O Block

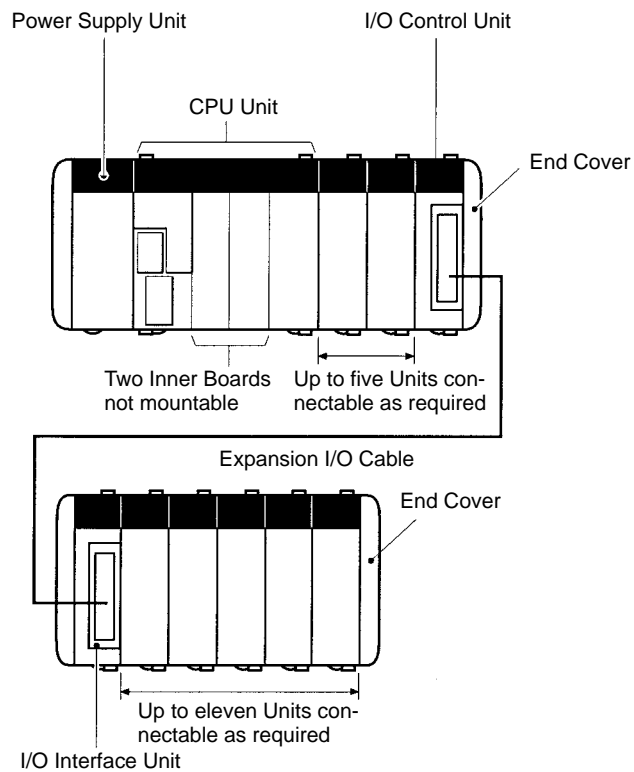

1-2-2 Connections to Programming Devices

Connections to personal computers running Support Software and connections to Programming Consoles are shown below.

Personal Computer

Connecting to CPU Unit's Peripheral Port

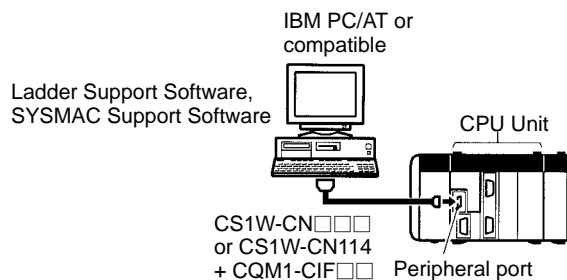

Connecting to CPU Unit's RS-232C Port

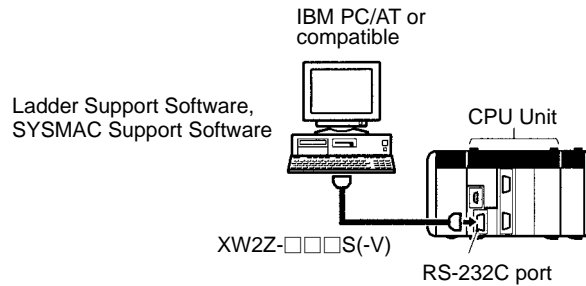

Note You can also connect to the RS-232C port on a Serial Communications Board.

Programming Console

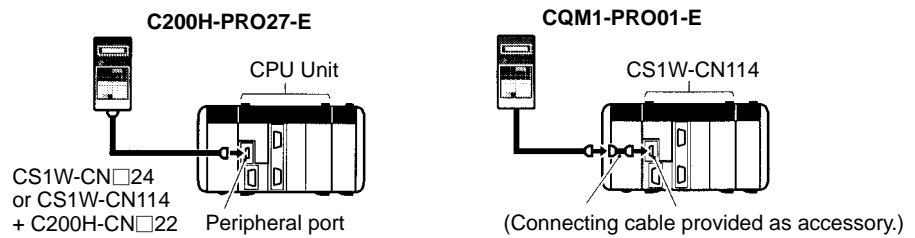

1-2-3 CPU Units

Basic Specifications

Model	Number of I/O points (see note)	Program capacity (words)	CPU Unit external input points	DM capacity (words)	EM capacity (words)	Built-in serial communications ports		Inner Boards	Communications Units
						Peripheral port	RS-232C port		
CQM1H-CPU61	512	15.2 K	DC: 16	6 K	6 K	With	With	Supported	Supported
CQM1H-CPU51		7.2 K		6 K	None				
CQM1H-CPU21	256	3.2 K		3 K	None	Without	Without	Not supported	Not supported
CQM1H-CPU11									

Note Number of I/O points = Number of input points (≤ 256) + Number of output points (≤ 256).

Maximum Number of Units

CPU Block Only

CPU Unit	Maximum number of Units connectable			
	Communications Units	Inner Boards	I/O Units	Dedicated I/O Units
CQM1H-CPU61	1	2	11	
CQM1H-CPU51				
CQM1H-CPU21	None	None		
CQM1H-CPU11				

CPU Block and Expansion I/O Block

CPU Unit	Maximum number of Units connectable			
	Communications Units	Inner Boards	I/O Units	Dedicated I/O Units
CQM1H-CPU61	1	2	5 on CPU Block	
CQM1H-CPU51			11 on Expansion I/O Block	
CQM1H-CPU21	None	None		
CQM1H-CPU11				

- Note**
1. An Analog Power Supply Unit is counted as one Unit, the same as I/O Units and Dedicated I/O Units.
 2. The Units that can be connected to the CPU Block and Expansion I/O Block are also limited by power supply capacity, as shown in the following table.

Block	Max. current consumption	
CPU Block	3.0 A (See note 2.)	5.0 A total (see note 1)
Expansion I/O Block	2.0 A (See note 3)	

- Note**
1. If the CQM1-PA203 Power Supply Unit is used, the maximum current consumption total is 3.6 A.
 2. Includes current consumed by the CPU Unit, Communications Unit, and Inner Boards.
 3. Includes current consumed by the I/O Control Unit.

1-2-4 Inner Boards

Name	Specifications	Model number
High-speed Counter Board	Pulse inputs (high-speed counter): 4 points (single-phase: 50 kHz/500 kHz switchable; phase difference: 1x/2x/4x multiplication ratio, 25 kHz/250 kHz switchable) External outputs: 4 points	CQM1H-CTB41
Pulse I/O Board	Pulse inputs (high-speed counter): 2 points (single-phase: 50 kHz, phase difference: 25 kHz) Pulse outputs: 2 points (50 kHz) (fixed duty factor and variable duty factor supported)	CQM1H-PLB21
Absolute Encoder Interface Board	Absolute encoder (gray code binary) inputs: 2 points (4 kHz)	CQM1H-ABB21
Analog Setting Board	Analog settings: 4 points	CQM1H-AVB41
Analog I/O Board	Analog inputs of 0 to 5 V, 0 to 20 mA, -10 to +10 V: 4 points Analog outputs of 0 to 20 mA, -10 to +10 V: 2 points	CQM1H-MAB42
Serial Communications Board	One RS-232C port and one RS-422A/485 port	CQM1H-SCB41

Mounting Combinations

CPU Unit and slot		Inner Board					
		High-speed Counter Board	Pulse I/O Board	Absolute Encoder Interface Board	Analog Setting Board	Analog I/O Board	Serial Communications Board
		CQM1H-CTB41	CQM1H-PLB21	CQM1H-ABB21	CQM1H-AVB41	CQM1H-MAB42	CQM1H-SCB41
CQM1H-CPU61/51	Slot 1 (left slot)	OK	Not possible	Not possible	OK	Not possible	OK
	Slot 2 (right slot)	OK	OK	OK	OK	OK	Not possible
CQM1H-CPU21/11		Not possible	Not possible	Not possible	Not possible	Not possible	Not possible

- Note**
1. High-speed Counter Boards can be mounted in both slots of the CQM1H-CPU51/61 simultaneously.

- 2. Analog Setting Boards cannot be mounted in both slots of the CQM1H-CPU51/61 simultaneously.

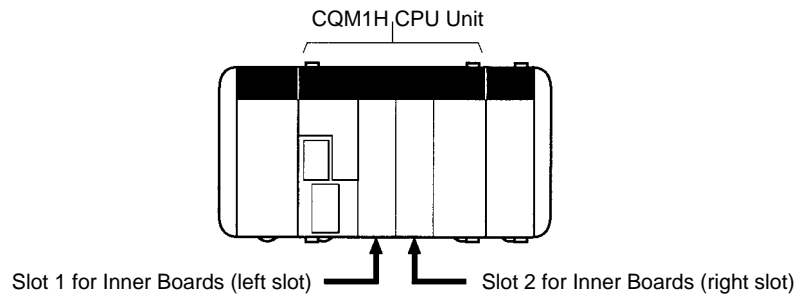

1-2-5 Communications Units

Name	Specifications	Model
Controller Link Unit (wired)	Data link (Maximum number of words per node: 8,000) Message communications (SEND/RECV/CMND instructions)	CQM1H-CLK21

Note A Communications Unit is connected between the Power Supply Unit and the CPU Unit. Communications Units cannot be connected to Expansion I/O Blocks.

1-2-6 Memory Cassettes

Model number	Memory	Capacity	Clock (see note)	Saveable data (saved together)			Reading/writing
				User programs	Data memory (read-only areas, PC Setup)	Expansion instruction information	
CQM1H-ME16K	Flash memory	16 Kwords	No	Yes	Yes	Yes	AR area: Memory Cassette ↔ CPU (comparison available) Automatic transfer at power ON: Memory Cassette → CPU
CQM1H-ME16R			Yes				
CQM1H-ME08K	EEPROM	8 Kwords	No	Yes	Yes	Yes	
CQM1H-ME08R			Yes				
CQM1H-ME04K			4 Kwords				
CQM1H-ME04R	Yes						
CQM1H-MP08K	EPROM	8K/16 Kwords (According to switch setting)	No	Yes	Yes	Yes	Read only: Memory Cassette → CPU
CQM1H-MP08R			Yes				

Note The accuracy of the clock is affected by the ambient temperature, as shown in the following table.

Ambient temperature	Accuracy by month
55°C	-3 to 0 min
25°C	±1 min
0°C	-2 to 0 min

1-2-7 Power Supply Units

Name	Specifications				Model number
	Supply voltage	Operating voltage range	Output capacity	Service power supply	
AC Power Supply Units	100 to 240 V AC, 50/60 Hz (wide range)	85 to 265 V AC	5 V DC: 3.6 A (18 W)	None	CQM1-PA203
			5 V DC: 6A 24 V DC: 0.5 A (30 W total)	24 V DC: 0.5 A	CQM1-PA206
	100 or 230 V AC (selectable), 50/60 Hz		5 V DC: 6A 24 V DC: 0.5 A (30 W total)		CQM1-PA216
DC Power Supply Units	24 V DC	20 to 28 V DC	30 W 5 V DC: 6 A	None	CQM1-PD026

1-2-8 Products for Expansion I/O Blocks

Name	Model	Specifications	
I/O Control Unit	CQM1H-IC101	Connected to right end of CPU Block.	
I/O Interface Unit	CQM1H-II101	Connected to the left end of Expansion I/O Block. An End Cover is provided.	
Expansion I/O Cable	CS1W-CN313	Length: 0.3 m	Connects the I/O Control Unit to the I/O Interface Unit.
	CS1W-CN713	Length: 0.7 m	

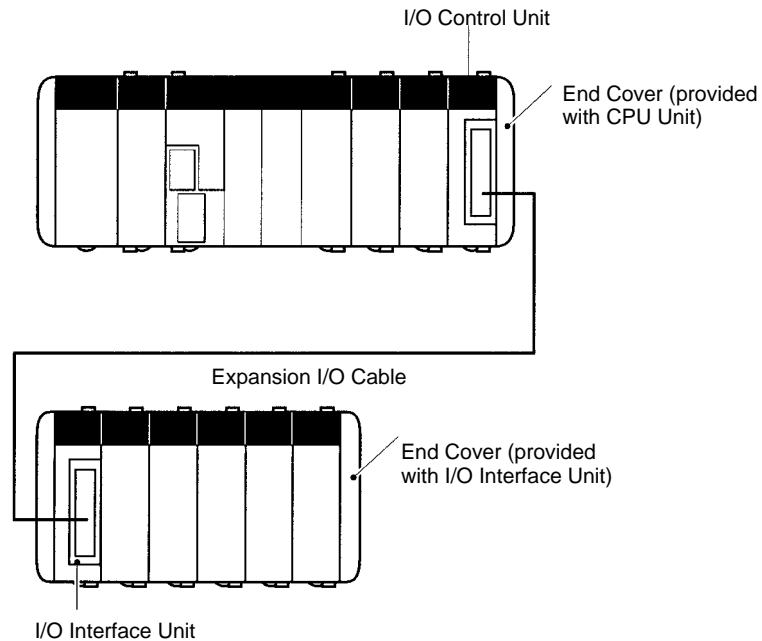

1-2-9 I/O Units

Name	Number of points	Specifications	Connection method	Model number	Input words allocated from IR 001	Output words allocated from IR 100
DC Input Units	8	12 to 24 V DC, independent commons (1 point per common, 8 circuits)	Terminal block	CQM1-ID211	1 word	---
	16	12 V DC (16 points per common, 1 circuit)		CQM1-ID111		
		24 V DC (16 points per common, 1 circuit)		CQM1-ID212		
	32	12 V DC (32 points per common)	Connector	CQM1-ID112	2 words	
		24 V DC (32 points per common)		CQM1-ID213		
		24 V DC (32 points per common)		CQM1-ID214		
AC Input Units	8	100 to 120 V AC (8 points per common)	Terminal block	CQM1-IA121	1 word	
		200 to 240 V AC (8 points per common)		CQM1-IA221		
Contact Output Units	8	2 A at 250 V AC ($\cos\phi = 1.0$) 2 A at 250 V AC ($\cos\phi = 0.4$) 2 A at 24 V DC (16 A per Unit), independent commons		CQM1-OC221	---	1 word
	16	2 A at 250 V AC ($\cos\phi = 1.0$) 2 A at 250 V AC ($\cos\phi = 0.4$) 2 A at 24 V DC (8 A per Unit)		CQM1-OC222		
	8	2 A at 250 V AC ($\cos\phi = 1.0$) 2 A at 250 V AC ($\cos\phi = 0.4$) 2 A at 24 V DC (16 A per Unit), independent commons		CQM1-OC224		
Transistor Output Units	8	2 A at 24 V DC (5 A per Unit) 8 points per common		CQM1-OD211		
	16	50 mA/4.5 V DC to 300 mA/26.4 V DC 16 points per common		CQM1-OD212		
	32	16 mA/4.5 V DC to 100 mA/26.4 V DC	Connector	CQM1-OD213		
		500 mA/24 V DC, PNP output		CQM1-OD216		
	16	300 mA/24 V DC, PNP output	Terminal block	CQM1-OD214		
8	1.0 A/24 V DC, PNP output (4A per Unit), short-circuit protection		CQM1-OD215	1 word		
Triac Output Units	8	0.4 A at 100 to 240 V AC, 4 points per common, 2 circuits		CQM1-OA221		
	6	0.4 A at 100 to 240 V AC		CQM1-OA222		

1-2-10 Dedicated I/O Units

Name	Specifications	Model number	Input words allocated from IR 001	Output words allocated from IR 100
Analog Input Unit	4 analog input points -10 to +10 V, 0 to 10 V, 1 to 5 V, 4 to 20 mA	CQM1-AD041	2 or 4 words	---
Analog Output Unit	2 analog output points -10 to +10 V, 0 to 20 mA	CQM1-DA021	---	2 words
Analog Power Supply Units	Power supply for Analog Input or Output Unit (required when using Analog Input or Output Unit)	CQM1-IPS01 (Supplies 1 Unit.)	---	---
		CQM1-IPS02 (Supplies 2 Units.)		
B7A Interface Units	16 output points	CQM1-B7A02	---	1 word
	16 input points	CQM1-B7A12	1 word	---
	32 output points	CQM1-B7A03	---	2 words
	32 input points	CQM1-B7A13	2 words	---
	16 input points and 16 output points	CQM1-B7A21	1 word	1 word
G730 Interface Units	2-wire transmission terminal G730 Master Unit (32 inputs/32 outputs max.) 32 points/16 points switchable	CQM1-G7M21	1 or 2 words	1 or 2 words
	For Expansion Master Input (32 points max.), 32 points/16 points switchable	CQM1-G7N11	1 or 2 words	---
	For Expansion Master Output (32 points max.), 32 points/16 points switchable	CQM1-G7N01	---	1 or 2 words
I/O Link Unit (SYSMAC BUS Wired Slave Unit)	For SYSMAC BUS Wired Slave Unit 32 input points and 32 output points	CQM1-LK501	2 words	2 words
Sensor Unit	Sensor input points: 4 max. Used with Sensor Module(s). Up to four Sensor Modules can be mounted to a single Sensor Unit.	CQM1-SEN01	1 word (Up to 5 words with following 4 Modules.)	---
Optical Fiber Photoelectric Module	For E32 series Fiber Units. Automatic teaching is supported.	E3X-MA11	1 word	---
Photoelectric Module with Separate Amplifier	For E3C-series Photoelectric Sensors. An automatic teaching function is incorporated	E3C-MA11	1 word	---
Proximity Module with Separate Amplifier	For E2C-series Proximity Sensors. Automatic teaching is supported.	E2C-MA11	1 word	---
Dummy Module	Mounted as spacers to the open slots of the CQM1 when no Sensor Module is mounted to the CQM1H.	E39-M11	1 word	---
Remote Console	Connected to a Sensor Unit for the adjustment of the sensitivities of the modules incorporated by the Sensor Unit, reading and changing of the set value, and teaching. Cable length: 3 m	CQM1-TU001	---	---

Name	Specifications	Model number	Input words allocated from IR 001	Output words allocated from IR 100
Temperature Control Units	2 thermocouple inputs (K/J), ON/OFF or advanced PID control, transistor (NPN) output, 2 loops	CQM1-TC001	1 or 2 words	1 or 2 words
	2 thermocouple inputs (K/J), ON/OFF or advanced PID control, transistor (NPN) output, 2 loops	CQM1-TC002	1 or 2 words	1 or 2 words
	2 platinum resistance thermometer inputs (Pt, JPt), ON/OFF or advanced PID control, transistor (NPN) output, 2 loops	CQM1-TC101	1 or 2 words	1 or 2 words
	2 platinum resistance thermometer inputs (Pt, JPt), ON/OFF or advanced PID control, transistor (NPN) output, 2 loops	CQM1-TC102	1 or 2 words	1 or 2 words
	2 thermocouple inputs (K/J/T/L/R/S/B), ON/OFF or advanced PID control, transistor (NPN) output, 4 loops	CQM1-TC201	1 word	1 word
	4 thermocouple inputs (K/J/T/L/R/S/B), ON/OFF or advanced PID control, transistor (PNP) output, 4 loops	CQM1-TC202	1 word	1 word
	4 platinum resistance thermometer inputs (Pt, JPt), ON/OFF or advanced PID control, transistor (NPN) output, 4 loops	CQM1-TC301	1 word	1 word
	4 platinum resistance thermometer inputs (Pt, JPt), ON/OFF or advanced PID control, transistor (PNP) output, 4 loops	CQM1-TC302	1 word	1 word
	2 thermocouple inputs (K/J/T/L/R/S/B), ON/OFF or advanced PID control, transistor (NPN) output, 2 loops, heater burnout detection function	CQM1-TC203	1 word	1 word
	2 thermocouple inputs (K/J/T/L/R/S/B), ON/OFF or advanced PID control, transistor (PNP) output, 2 loops, heater burnout detection function	CQM1-TC204	1 word	1 word
	2 platinum resistance thermometer inputs (Pt, JPt), ON/OFF or advanced PID control, transistor (NPN) output, 2 loops, heater burnout detection function	CQM1-TC303	1 word	1 word
	2 platinum resistance thermometer inputs (Pt, JPt), ON/OFF or advanced PID control, transistor (PNP) output, 2 loops, heater burnout detection function	CQM1-TC304	1 word	1 word
	Linear Sensor Interface Units	Measure voltage or current inputs from linear sensors and convert the measurements to numeric data for comparative decision processing. Standard type	CQM1-LSE01	1 word
With monitor output (-9.999 V to 9.999 V).		CQM1-LSE02	1 word	1 word
CompoBus/S Master Unit	128 points (64 inputs and 64 outputs), 64 points (32 inputs and 32 outputs), or 32 points (16 inputs and 16 outputs) selectable with a switch.	CQM1-SRM21-V1	1,2 or 4 words	1,2 or 4 words
CompoBus/D (DeviceNet) I/O Link Unit	CompoBus/D Slave: 32 points (16 inputs and 16 outputs)	CQM1-DRT21	1 word	1 word

1-2-11 Accessories

DIN Track

Name	Specifications	Model number
DIN Track	Track length: 1 m	PFP-100N
	Track length: 50 cm	PFP-50N
	Track length: 1 m	PFP-100N2
DIN Track Brackets	Mounting brackets fastened on both sides of the PC to prevent it from sliding left or right. Two are provided with the CPU Unit.	PFP-M

Maintenance Accessories

Name	Model number
Backup Battery	CPM2A-BAT01
End Cover	CQM1H-TER01

Inner Board Connectors

Inner Board	Name of connector on cable	Model number	Remarks
High-speed Counter Board, Pulse I/O Board, Absolute Encoder Interface Board, Analog I/O Board	Socket	XM2D-1501	Standard accessories for each Board
	Hood	XM2S-1511	

Cables for Connecting Pulse I/O Boards to OMRON Servo Drivers

Inner Board	Relay Cable	Servo Relay Unit	Cable	Servo Driver
Pulse I/O Board (pulse outputs)	XW2Z-□□□J-A3	XW2B-20J6-3B	For U-series Servo Drivers: XW2Z-□□□J-B1	R88D-UP□□□
			For M-series Servo Drivers: XW2Z-□□□J-B2	R88D-MT□□□
			For H-series Servo Drivers: XW2Z-□□□J-B3	R88D-H□□□

Cables for Connecting Absolute Encoder Interface Boards to OMRON Absolute Encoders

Inner Board	Cable	Compatible OMRON Absolute Encoder
Absolute Encoder Interface Board	E69-DC5	E6F-AG5C-C E6CP-AG5C-C E6C2-AG5C-C

Connectors for 32-point I/O Units

I/O Unit	Connector type		Model number (by Fujitsu)	Set model number (from OMRON)
CQM1-ID112/213 (32 inputs) CQM1-OD213 (32 outputs)	Soldered (Standard accessory)	Socket	FCN-361J040-AU	C500-CE404
		Connector cover	FCN-360C040-J2	
	Crimped	Housing	FCN-363J040	C500-CE405
		Contact	FCN-363J-AU	
		Connector cover	FCN-360C040-J2	
	Pressure welded		FCN-367J040-AU	C500-CE403

Cables for 32-point I/O Units

Purpose	I/O Unit	Connecting cable	Connector-Terminal Block Conversion Unit	
For connections to Terminal Blocks	CQM1-ID112/213 (32 inputs) CQM1-OD213 (32 outputs)	XW2Z-□□□B	XW2B-40G5	M3.5 terminal screws
			XW2B-40G4	M2.5 terminal screws
	CQM1-ID112/213 (32 inputs)	XW2Z-□□□D	XW2C-20G5-IN16	Common type

Purpose	I/O Unit	Connecting Cable	I/O Relay Terminal for input or output
For connections to Relay Terminals	CQM1-ID112/213 (32 inputs)	G79-I□C-□	G7TC-I□16
	CQM1-OD213 (32 outputs)	G79-O□C-□	G7TC-OC□□, G70D, G70A

1-2-12 Maximum Number of I/O Units and I/O Points

The maximum number of I/O Units, Dedicated I/O Units, Communications Units, and Inner Boards that can be connected and the maximum number of I/O points (i.e., allocated words) that can be controlled are listed in the following table.

CPU Block Only

CPU Unit	No. of I/O Units and Dedicated I/O Units	No. of Communications Units	No. of Inner Boards	Max. I/O points* (allocated words)
CQM1H-CPU61	11 max.	1 max.	2 max.	512 (32 words)
CQM1H-CPU51				
CQM1H-CPU21	11 max.	Connection not supported	Connection not supported	256 (16 words)
CQM1H-CPU11				

Note *Number of I/O points = Number of input points (≤ 256) + Number of output points (≤ 256).

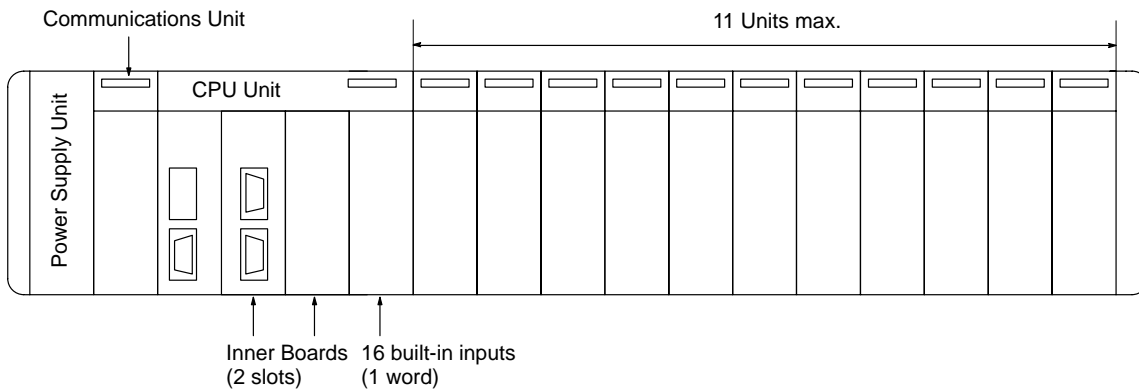

CPU Block and Expansion I/O Block

CPU Unit	No. of I/O Units and Dedicated I/O Units (see note 1)		No. of Communications Units	No. of Inner Boards	Max. I/O points (see note 2) (allocated words)
	CPU Block	Expansion I/O Block			
CQM1H-CPU61	5 max.	11 max.	1 max.	2 max.	512 (32 words)
CQM1H-CPU51					
CQM1H-CPU21					
CQM1H-CPU11			Connection not supported		

- Note**
1. An Analog Power Supply Unit is counted as one Unit, the same as I/O Units and Dedicated I/O Units.
 2. I/O points = Input points (256 max.) + Output points (256 max.)

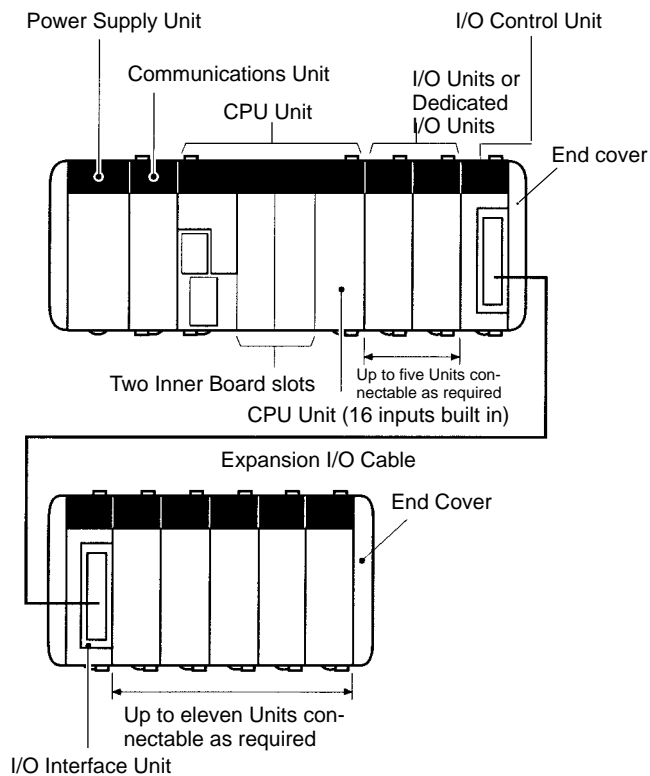

Exceeding the Maximum Number of I/O Units

When only a CPU Block is used, a maximum of 11 I/O Units and Dedicated I/O Units can be connected to the CQM1H-series CPU Unit. When an Expansion I/O Block is also used, a maximum of 5 I/O Units and Dedicated I/O Units can be connected to the CQM1H-series CPU Unit and a maximum of 11 I/O Units and Dedicated I/O Units can be connected to the Expansion I/O Block. If these limits are exceeded, the CQM1H may not operate properly because of drops in the voltage of the 5-V internal power supply. The CQM1H will detect if the maximum number of I/O points has been exceeded (as explained below), but will not detect if the maximum number of Units has been exceeded. Therefore, design the system so that the maximum number of Units is not exceeded.

Exceeding Maximum Number of I/O Points

When the maximum number of I/O points is exceeded, an "I/O UNIT OVER" message will be displayed and operation will stop. For details on I/O UNIT OVER errors, refer to the *CQM1H Programming Manual*.

The relationship between the maximum number of I/O points and Unit word allocation is shown in the following table. The CPU Unit has 16 built-in inputs for which one word is allocated.

CPU Unit	Max. no. of I/O points	Input allocation		Output allocation	Requirements
		CPU Unit	Connected Units	Connected Units	
CQM1H-CPU61	512 (32 words)	1 word	n words	m words	$1 + n + m \leq 32$ ($n, m \leq 16$)
CQM1H-CPU51					
CQM1H-CPU21	256 (16 words)	1 word	n words	m words	$1 + n + m \leq 16$ ($n, m \leq 16$)
CQM1H-CPU11					

Refer to the *CQM1H Programming Manual* for the number of words allocated to each Unit and other information on memory allocation to Units.

- Note**
1. It is possible to exceed the maximum number of Units without exceeding the maximum number of I/O points (and words allocated). For example, with the CQM1H-CPU61, if 12 Units that are allocated 1 word each are connected, the total number of words allocated will be 13 (including the 1 word allocated for the CPU Unit built-in inputs), which is less than the specified maximum. The number of Units, however, exceeds the maximum of 11.
 2. It is also possible to exceed the maximum number of I/O points (and words allocated) without exceeding the maximum number of Units. For example, with the CQM1H-CPU61, if 8 Units that are allocated 4 words each are connected, the maximum number of Units is not exceeded. However, the total word allocation will be $(4 \times 8) + 1 = 33$ words (including the 1 word allocated for the CPU Unit built-in inputs), and so consequently the maximum number of 32 words is exceeded.

1-3 Expanded System Configuration

1-3-1 Serial Communications System

The CQM1H system configuration can be expanded by using the following serial communications ports.

- CPU Unit built-in ports, 2 ports: Peripheral port and RS-232C port
- Serial Communications Board ports, 2 ports: RS-232C port and RS-422/485 port (CQM1H-CPU51/61 only)

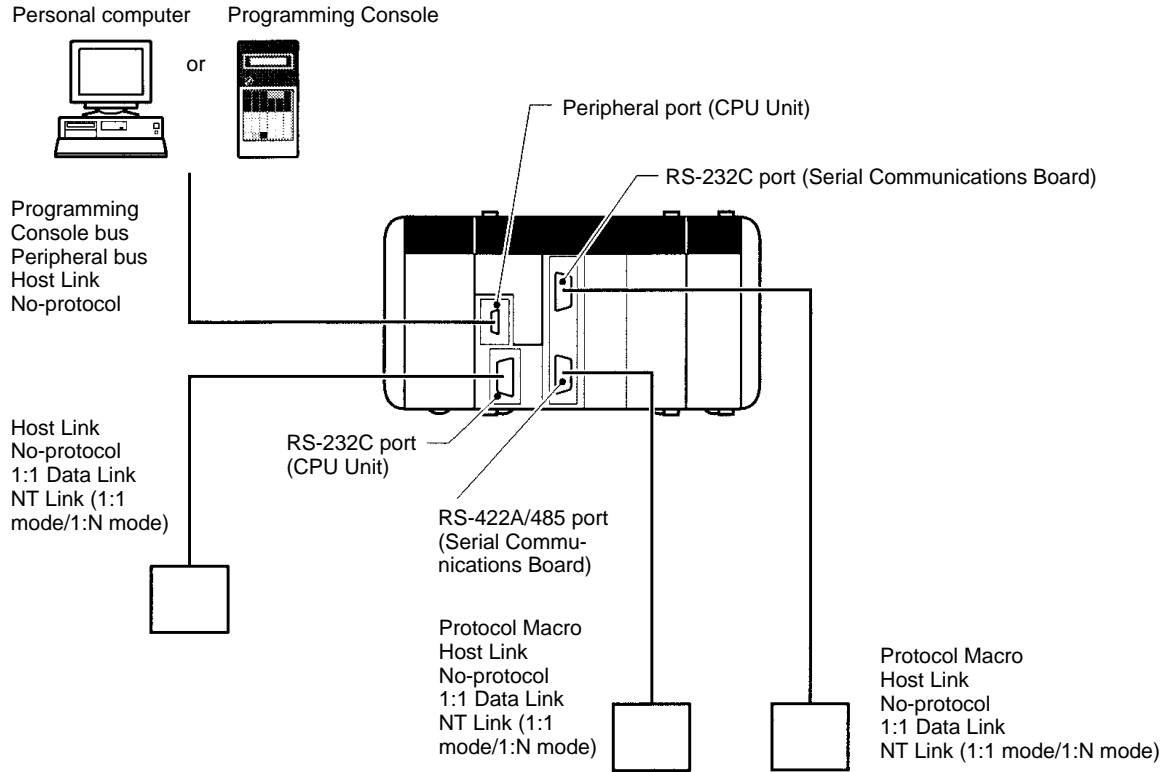

Communications Ports and Serial Communications Modes (Protocols)

Serial communications protocol	Application	CPU Unit		CQM1H-SCB41 Serial Communications Board	
		Peripheral port	RS-232C port (Not on CQM1H-CPU11)	RS-232C port (port 1)	RS-422A/485 port (port 2)
Programming Console bus	Communications with Programming Consoles	YES	No	No	No
Peripheral bus	Communications with Programming Devices	YES	No	No	No
Host Link (SYSMAC WAY)	Communications with a host computer or PT	YES	YES	YES	YES
Protocol macro	Sending and receiving messages according to the communications specifications of external devices	No	No	YES	YES
No-protocol	No-protocol communications with general-purpose devices	YES	YES	YES	YES
1:1 Data Link	Data links with other CPU Units	No	YES	YES	YES
NT Link (1:1 mode)	One-to-one communications with PT	No	YES (See note.)	YES	YES
NT Link (1:N mode)	One-to-one or one-to-many communications with PTs	No	No	YES	YES

Note Programming Console functions are possible with a PT. They are, however, not possible when pin 7 on the DIP switch on the front of the CPU Unit is OFF.

Protocols

The serial communications port protocol can be switched in the CPU Unit's PC Setup. Depending on the protocol selected, the following systems can be configured to support serial communications.

Protocol	Main connection	Application	Applicable commands, communications instructions
Programming Console bus	Programming Console	Communications between Programming Console and PC	None
Peripheral bus (see note)	Programming Devices, e.g., CX-Programmer	Communications between Programming Devices and the PC from the computer	None
Host Link	Personal computer OMRON Programmable Terminals	Communications between the host computer and the PC Commands can be sent to a computer from the PC.	Host Link commands/ FINS commands Commands can be sent to a computer from the PC.
Protocol macro	General-purpose external devices	Sending and receiving messages (communications frames) according to the communications specifications of external devices SYSMAC-PST is used to create protocols by setting various parameters.	PMCR(—) instruction
No-protocol communications	General-purpose external devices	No-protocol communications with general-purpose devices	TXD(—) and RXD(—) instructions
1:1 Data Link	C-series PCs	Shared link words between PCs	None
NT Link (1:1)	OMRON Programmable Terminals	High-speed one-to-one communications with a Programmable Terminal using direct access	None
NT Link (1: N)	OMRON Programmable Terminals	High-speed one-to-one or one-to-many communications with Programmable Terminals using direct access	None

Note The peripheral bus mode is used for Programming Devices other than Programming Consoles (e.g., CX-Programmer).

**Host Link System
(SYSMAC WAY Mode,
1:N)**

The Host Link System allows the I/O memory of the PC to be read/written, and the operating mode to be changed from a host computer (personal computer or Programmable Terminal) by executing Host Link commands. Other Programming Devices can also be connected via a computer using this mode. Alternatively, it is also possible to send data from the CPU Unit of the CQM1H to the host computer using TXD(—) instructions to initiate communications from the PC. This mode is supported by the peripheral port and the RS-232C port on the CPU

Unit, as well as the RS-232C port and RS-422A/485 port on the Serial Communications Board.

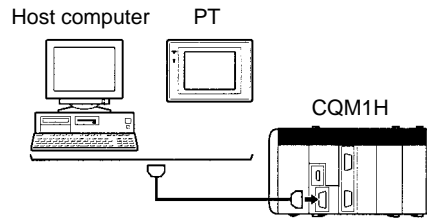

For details on cables required to connect the host computer to the CQM1H in Host Link Mode, refer to 3-6 Programming Devices.

No-protocol Communications

The TXD(—) and RXD(—) instructions in the ladder program can be used with no communications protocol or conversion to transfer data with a general-purpose external device equipped with an RS-232C port. It is possible to attach a start code to the beginning and an end code to the end of data (or specify the amount of data) when sending/receiving. Unlike protocol macro, it is not possible to construct a communications frame (message) according to the communications specifications of the communications partner. Also, there are no procedures for retry processing, data format conversion processing or branch processing for receiving data. This communications mode is thus used for simple data transmissions, such as inputting bar code data and outputting printer data. This mode is supported by the peripheral port and the RS-232C port on the CPU Unit, as well as the RS-232C port and RS-422A/485 port on the Serial Communications Board.

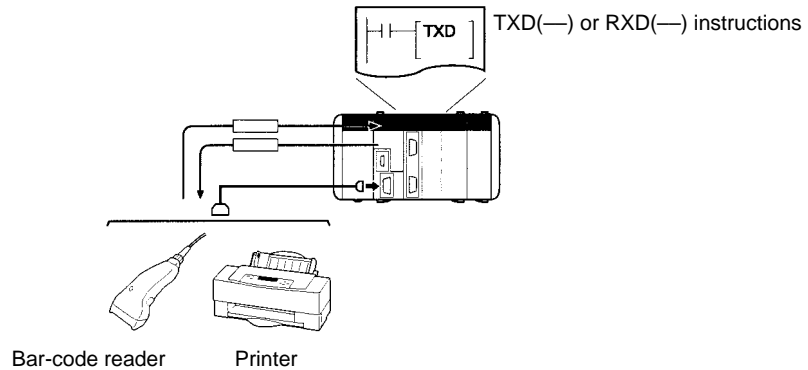

1:1 Data Link System

If two PCs are linked one-to-one by connecting them together through their RS-232C ports, they can share up to 64 words of LR area. One of the PCs will serve as the master and the other as the slave.

One of the following three ranges of words can be set to be linked:
 LR 00 to LR 63, LR 00 to LR 31, or LR 00 to LR 15

A 1:1 Data Link communications system can be created between the CQM1H and another CQM1H, or between the CQM1H and the CQM1, C200HX/HG/HE, C200HS, CPM1, CPM1A, CPM2A, CPM2C, or SRM1(-V2).

Note The link area will always be LR 00 to LR 15 (16 words) for 1:1 Data Link communications with the CPM1, CPM1A, CPM2A, CPM2C, or SRM1(-V2).

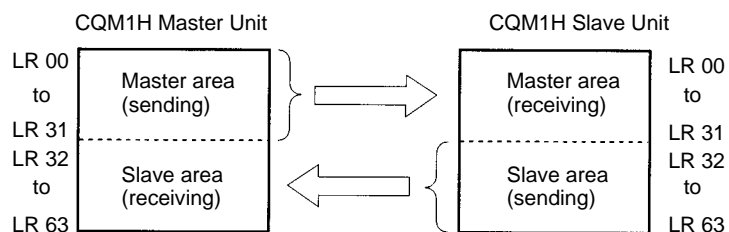

This mode is supported by the RS-232C port on the CPU Unit, as well as the RS-232C port and RS-422A/485 port on the Serial Communications Board.

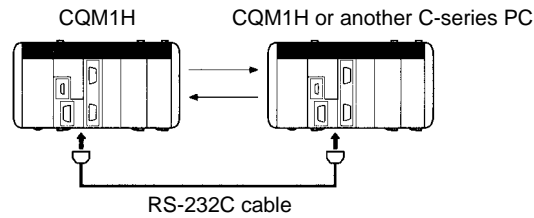

Wiring

Connect the Units with the cables wired as shown below.

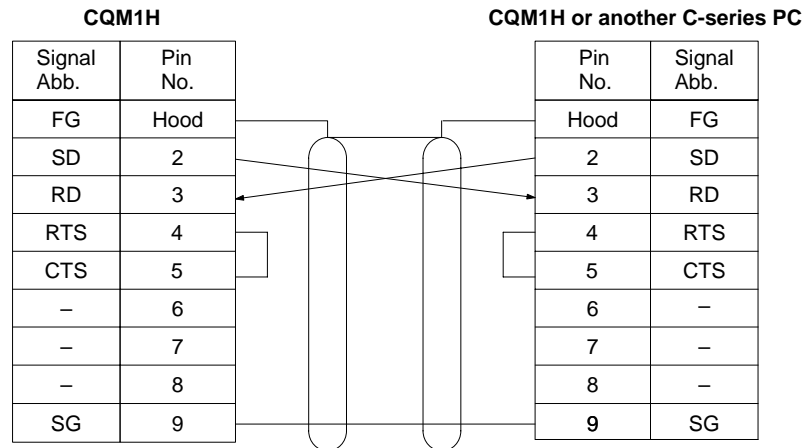

Recommended Cables

- UL2464 AWG28x5P IFS-RVV-SB (UL-approved, Fujikura Ltd.)
- AWG28x5P IFVV-SB (not UL standard) (not UL-approved, Fujikura Ltd.)
- UL2464-SB (MA) 5Px28AWG (7/0.127) (UL-approved, Hitachi Cable, Ltd.)
- CO-MA-VV-SB 5Px28AWG (7/0.127) not UL-approved, Hitachi Cable, Ltd.)

Applicable Connectors (Standard Accessories for CQM1H)

Socket: XM2A-0901 (OMRON); Hood: XM2S-0911-E (OMRON)

NT Link System

If a PC and Programmable Terminal (PT) are connected together using RS-232C or RS-422A/485, the allocations for the PT's status control area, status notify area, and objects (such as touch switches, indicators, and memory maps) can be allocated in the I/O memory of the PC. The NT Link System allows the PT to be controlled by the PC, and the PT can periodically read data from the status control area of the PC to perform necessary operations if there are any changes in the area. The PT can communicate with the PC by writing data to the status notify area or the I/O memory of the PC from the PT. The NT Link system allows the PT status to be controlled and monitored without using the PC's ladder program.

There are two NT Link modes: One is for communications between one PC and one PT (1:1 mode), and the other is for communications between one PC, and one or many PTs (1:N mode). These modes support completely different communications.

NT Link: 1:1 Mode

This mode is used for communications between one PC and one PT. This mode is supported by the RS-232C port on the CPU Unit, as well as the RS-232C port and RS-422A/485 port on the Serial Communications Board. The 1:1 NT Link

mode is supported for communications between only one PC and one PT. Set the PT communications settings for a 1:1 NT Link.

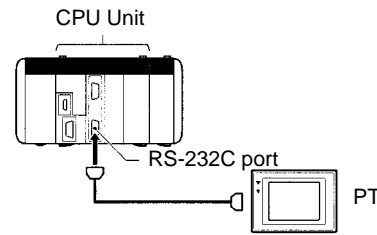

Link Mode: 1:N Mode

This mode is used for communications between one PC and n ($8 \geq n \geq 1$) PTs. This mode is supported by the RS-232C port on the CPU Unit, as well as the RS-232C port and RS-422A/485 port on the Serial Communications Board. The 1:N NT Link mode is supported for communications between one PC and one or more PTs. Set the PT communications settings for a 1:N NT Link.

NT Link: 1:1 Mode

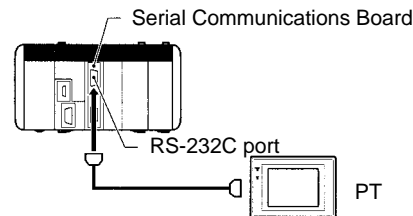

NT Link: 1:N Mode

Connection to RS-232C port of Serial Communications Board

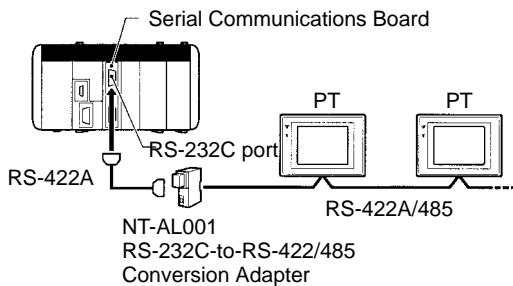

Connection to RS-422A/485 port of Serial Communications Board

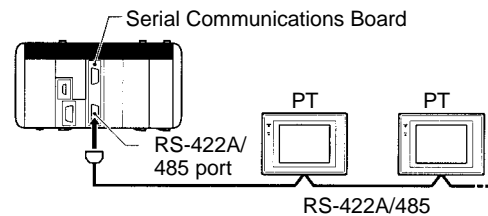

Note The 1:1 NT Link mode and 1:N NT Link mode use different types of serial communications and there is no data compatibility between them.

Protocol Macros

The CX-Protocol is used to create sets of data transmission procedures called protocols for general-purpose external devices according to the communications specifications of the general-purpose external devices. Communications must be half-duplex and must use start-stop synchronization. The protocols that have been created are recorded in a Serial Communications Board, enabling data to be sent to and received from the external devices by simply executing the PMCR(—) instruction in the CPU Unit. Protocols for data communications with OMRON devices, such as Temperature Controllers, Intelligent Signal Processors, Bar Code Readers, and Modems, are supported as standard protocols (see note 1). These protocols can be changed to suit user needs. Protocol macros are supported by the RS-232C port and RS-422A/485 port on the Serial Communications Board (see note 2).

Note 1. The standard protocols are provided as standard features with the CX-Protocol and Serial Communications Boards.

2. Protocol macros not supported by the CPU Unit's built-in ports.

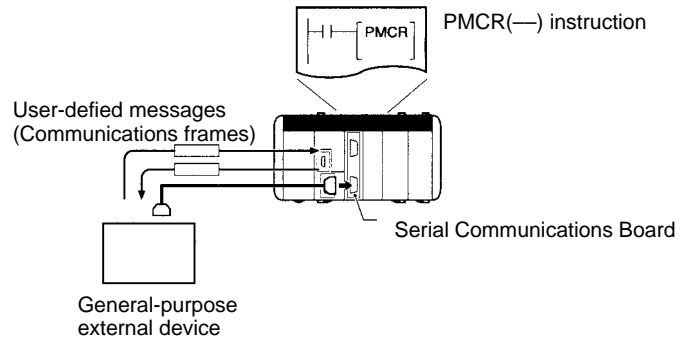

Note CompoWay/F (Host Function)

A CQM1H CPU Unit can operate as a host to send CompoWay/F commands to OMRON components connected in the system. CompoWay/F commands are executed by using the CompoWay/F send/receive sequences in one of the standard protocols provided in the protocol macros.

1-3-2 Communications Networks

With the CQM1H CPU Unit, networks can be created using the following Communications Units:

- CompoBus/S Master Unit
- Controller Link Unit (CQM1H-CPU51/61 only)

CompoBus/S Network

CompoBus/S is a high-speed ON/OFF bus for remote I/O communications. Connecting a CQM1-SRM21-V1 CompoBus/S Master Unit (a Dedicated I/O Unit) to the network allows remote I/O communications, without programming in the CPU Unit, between the PC and Slaves. High-speed communications are performed with 256 points in a cycle time of 1 ms max. With the CQM1H-SRM21-V1, a long-distance communications mode is also available in addition to the previous high-speed communications mode, enabling communications on a trunk line of up to 500 m.

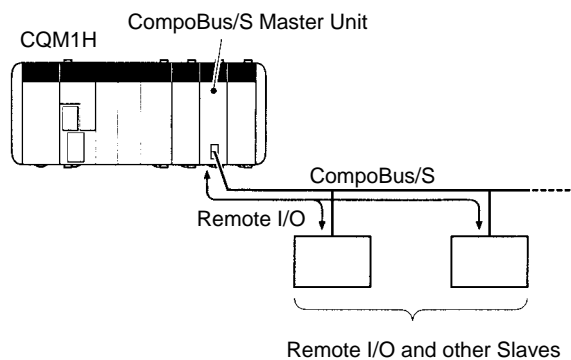

Controller Link Network

The Controller Link Network is the basic network of the OMRON PC FA Networks. When using a CQM1H-CPU51/61 CPU Unit, the CQM1H can be connected to the network using a Controller Link Unit. This enables the flexible and simple transfer of large amounts of data with other OMRON PCs (e.g., CQM1H, CS1, C200HX/HG/HE, CVM1, and CV-series PCs) or with personal computers. Data links can be created between PCs so that data can be shared without programming and FINS message communications can be performed, enabling separate control and data transfer when required. In particular, direct setting us-

ing data links allows the creation of a flexible data link system with effective use of data areas.

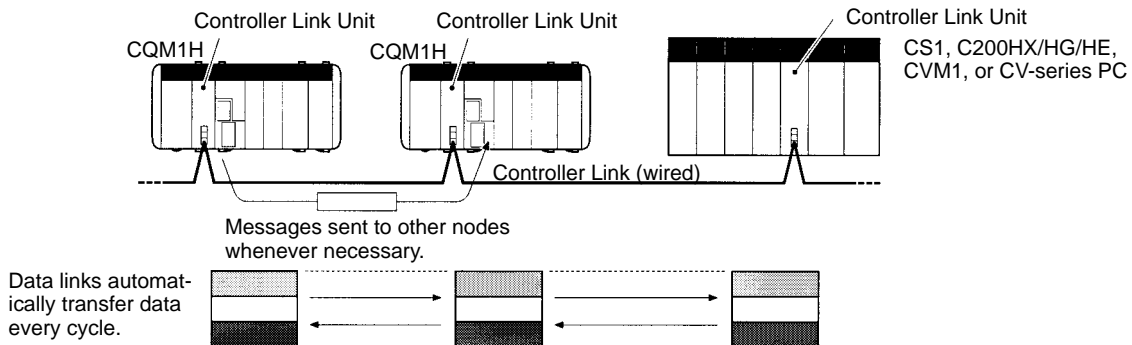

1-4 Functions Listed by Purpose

Purpose		Unit/Board	Function	Details
System design	Connecting 12 or more I/O or Dedicated I/O Units	I/O Control Unit and I/O Interface Unit	Using an Expansion I/O Block	You can connect up to 5 Units to the CPU Block and 11 Units to the Expansion I/O Block.
	Installing a PC in a narrow space			
Cycle time settings	Creating a minimum cycle time	CPU Unit	PC Setup: Cycle Time, Minimum Cycle Time	Set in DM 6619 (0001 to 9999 ms).
	Stopping operation if the cycle time exceeds a set time		PC Setup: Cycle Monitor Time	Set in DM 6618 (00 to 99; setting units: 10 ms, 100 ms, 1 s).
	Detecting when the cycle time exceeds 100 ms		SR area: Cycle Time Over Flag	SR 25309 turns ON.
	Detecting the maximum and current values of the cycle time		AR area: Maximum Cycle Time, Current Cycle Time	Maximum Cycle Time is stored in AR 26, and the Current Cycle Time is stored in AR 27.
Refresh method	Refreshing an output whenever an OUTPUT instruction is executed	CPU Unit	PC Setup: Output Refresh Method, Direct	Set direct output refresh method in DM 6639 bits 00 to 07. Output is refreshed when OUT is executed in the user program.
	Refreshing inputs when an interrupt occurs		PC Setup: First Input Refresh Word and Number of Input Refresh Words for interrupts	Set input refresh word for each interrupt in DM 6630 to DM 6638. The inputs for the specified words will be refreshed before the interrupt subroutine is executed when input interrupt, interval timer interrupt, or high-speed counter interrupt occurs.

Purpose		Unit/Board	Function	Details
Debugging	Turning OFF outputs from Output Units in any operating mode (stopping output refreshing)	CPU Unit	SR area: Output OFF Bit	Turn ON SR 25215.
	Detecting ON-to-OFF and OFF-to-ON transitions in specified bits		Differential Monitoring (from Programming Device)	---
	Sampling specified I/O memory data		Data Tracing	Sampling can be set to be performed at regular intervals, at the end of each cycle, or according to timing defined by the user.
	Changing the program during operation		Online Editing (from Programming Device)	---
Maintenance	Maintaining status of all outputs when operation stops	CPU Unit	SR area: I/O Hold Bit	Turn ON SR 25212.
	Starting operation with I/O memory in saved status			
	Maintaining I/O memory status when power is turned ON		SR area: I/O Hold Bit PC Setup: I/O Hold Bit Status, Maintain	Turn ON SR 25212 and set DM 6601 bits 08 to 11 in the PC Setup to maintain the I/O Hold Bit status at startup.
	Enabling input condition to be set using the DIP switch pin instead of Input Units (e.g., switching between trial and actual operation)		DIP switch: DIP switch pin customized for user operation is stored in the AR area.	Pin 6 setting is stored in the AR 0712.
	Write-protecting Program Memory and read-only DM data (general-purpose read-only area and PC Setup only) from a Peripheral Device		DIP switch: Program and data memory write-protection	Turn ON pin 1 on the DIP switch to prohibit writing.
	Specifying the startup mode		PC Setup: Startup Mode	Set in DM 6600 bits 00 to 07
	Counting the times power turned OFF		AR area: Power OFF Counter	Monitor AR 23.
Failure diagnosis	Handling user-defined errors and continuing or stopping PC operation accordingly	CPU Unit	User error instructions	FAL(06) and FALS(07)
	Performing time diagnosis and logic diagnosis for one section of the program		FPD(—) instruction	---
	Recording time-stamped errors, including user-defined errors		Error log	A logging function for input bits using FAL(06) and FALS(07) instruction is also supported.

Purpose		Unit/Board	Function	Details
Instructions	Creating step control programs	CPU Unit	Step programming instructions	---
	Performing floating-point math		Floating-point math instructions	---
	Performing trigonometric, logarithmic, or exponential functions on numerical data			
	Creating ladder subroutines that can be used at different places in the ladder program, changing only the operands.		MACRO instruction	(MCRO(99))
Memory Cassette	Changing systems when changing processes or machines	Memory Cassette	DIP switch: Automatic transfer of Memory Cassette contents	Turn ON pin 2 on the DIP switch for automatic transfer of Memory Cassette contents. At startup, user programs, part of the DM area (read-only DM and PC Setup) and expansion instruction information will be automatically read from the Memory Cassette to the CPU Unit.
	Transferring and verifying data between Memory Cassette and CPU Unit according to AR area settings		AR area: Backup functions	Turn ON AR 1400 to transfer data from the CPU Unit to the Memory Cassette. Turn ON AR 1401 to transfer data from the Memory Cassette to the CPU Unit. Turn ON AR 1402 to compare contents of Memory Cassette and CPU Unit data. (Results output to AR 1403.)
	Using clock functions to store data, such as error logs, with time of error occurrence	Memory Cassette with clock	AR area: Clock function	Use a Memory Cassette with a clock to store time data (minutes, hours, seconds, day of month, month, year, day of week) in AR 17 to AR 21.
Others	Reducing influence from chattering of input points and external noise	CPU Unit	PC Setup: Input Time Constants	Set input time constants for DC Input Units in DM 6620 to DM 6627. Settings available: 1, 2, 4, 8, 16, 32, 64, 128 ms.

Purpose	Unit/Board	Function	Details
Interrupt functions Processing interrupt when an input turns ON Example: Cut-to-length processing (sending instruction to a tool when interrupt input is received from a proximity or photoelectric sensor)	CPU Unit (built-in inputs)	Input interrupts (4 inputs): Input Interrupt Mode Input interrupt permitted by clearing mask using the INT(89) instruction with CC=000.	Interrupt subroutine is executed when CPU Unit built-in input (IR 00000 to IR 00003) turns ON.
Processing interrupts at regular intervals Example: Sheet speed calculation (calculates speed using input signals from an encoder at regular intervals)		Interval timer interrupt: Scheduled Interrupt Mode Specified with the first operand of the STIM(69) instruction.	Interrupt subroutine is executed at regular intervals.
Processing interrupt after a fixed time Example: Stopping conveyor belt with high precision after workpiece detected (independent of cycle time)		Interval timer interrupt: One-shot Mode Three interval timers (0 to 2). (Interval timer 2 cannot be used at the same time as high-speed counter 0.) Specified with the first operand of STIM(69).	Interrupt subroutine is executed once when the time expires.
Processing interrupt when the PV of a low-speed (1 kHz) counter reaches 0 Example: Counting workpieces (e.g., chip components), and stopping feeding when a set value is reached		Input interrupts (4 inputs): Counter Mode (decrementing) Counter Mode set value updated and masking cleared using the INT(89) instruction with CC=003.	Decrements the PV every time CPU Unit built-in input (IR 00000 to IR 00003) turns ON, and executes the subroutine when the PV reaches 0.
Processing interrupt when the high-speed counter PV matches a certain value Example: Performing processing required for cutting a workpiece (e.g., wire) when it is a certain length	CPU Unit (built-in inputs) Pulse I/O Board Absolute Encoder Interface Board	High-speed counter interrupt: Target value comparison	Interrupt subroutine is executed when the PV matches a value registered in the comparison table.
Processing interrupt when the high-speed counter PV is within a certain range Example: Picking workpieces (e.g., wires) within specified lengths at high speed		High-speed counter interrupt: Range comparison	Interrupt subroutine is executed when the counter PV lies between set upper and lower limits.
Interrupting program when data is received via serial communications	Serial Communications Board	Protocol macro interrupt notification	---

Purpose	Unit/Board	Function	Details	
High-speed counter functions	Detecting position and length when input is received from incremental rotary encoder			
	Low-speed (1 kHz) frequency count	CPU Unit (built-in inputs)	Input interrupt: Counter Mode (decrementing, 1 kHz)	CPU Unit built-in inputs (IR 00000 to IR 00003) can be used as high-speed counters without executing interrupt. PVs are stored in SR 244 to SR 247.
	Low-speed (2.5 kHz/5 kHz) frequency count		High-speed counter 0: Differential Phase Mode (2.5 kHz) Incrementing Mode (5 kHz)	High-speed pulse input from CPU Unit built-in inputs (IR 00004 to IR 00006) is counted. PVs are stored in SR 230 and SR 231.
	High-speed (25 kHz/50 kHz or 250 kHz/500 kHz) frequency count	High-speed Counter Board	High-speed counters 1 to 4: Differential Phase Mode (25 kHz/250 kHz, multiplication factor: 1/2/4) Pulse + Direction Mode (50 kHz/500 kHz) Up/Down Mode (50 kHz/500 kHz)	High-speed pulse input from ports 1, 2, 3 and 4 of the High-speed Counter Board is counted. For slot 1, the PVs are stored in IR 200 to IR 207 and for slot 2, in SR 232 to SR 239. (Ring mode or linear mode can be set as the numeric range.)
	High-speed (25 kHz/50 kHz) frequency count	Pulse I/O Board	High-speed counters 1 and 2: Differential Phase Mode (25 kHz) Pulse + Direction Mode (50 kHz) Up/Down Mode (50 kHz)	High-speed pulse input from ports 1 and 2 of the High-speed Counter Board is counted. For slot 1, the PVs are stored in IR 200 to IR 207 and for slot 2, in SR 232 to SR 239. (Ring mode or linear mode can be set as the numeric range.)
High-speed counting of signals from an absolute rotary encoder	Absolute Encoder Interface Board	High-speed counters 1 and 2: Input modes: BCD Mode and 360° Mode Resolution settings: 8-bit (0 to 255), 10-bit (0 to 1023), 12-bit (0 to 4095) Set the resolution to match the connected encoder.	Binary Grey code input from an absolute rotary encoder is counted. The PVs are stored in SR 232 to SR 235.	

Purpose		Unit/Board	Function	Details
Pulse output functions	Making simple pulse outputs	CPU Unit	PC Setup and SPED(64)/PULS(65) instructions: Pulse outputs can be made from standard Transistor Output Units.	Set the pulse output word address (specify a word from IR 100 to IR 115). Frequency: 20 Hz to 1 kHz Duty factor: 50%
	Making output to pulse train input motor driver (servomotor driver or stepping-motor driver) for positioning	Pulse I/O Board	Ports 1 and 2: Single-phase pulse output without acceleration/deceleration (using SPED(64) instruction) Trapezoidal single-phase pulse output with same acceleration and deceleration rates (using PLS2(--)) instruction) Trapezoidal single-phase pulse output with different acceleration/deceleration rates (using ACC(--)) instruction)	Frequency: 10 Hz to 50 kHz for servodriver; 10 Hz to 20 kHz for stepping motor Duty factor: 50% Pulse output PVs stored in SR 236 to SR 239.
	Performing time-proportional control of temperature using variable duty factor pulse output function		Ports 1 and 2: Variable duty factor pulse output (using PWM(--)) instruction)	Frequency: 5.9 kHz, 1.5 kHz, 91.6 Hz Duty factor: 1% to 99% Pulse output PVs stored in SR 236 to SR 239.
Analog setting	By setting the time for which a conveyor belt is temporarily stopped, the low-speed feed rate over a fixed distance can be simply controlled using the adjuster.	Analog Setting Board	Analog setting function	Values indicated by the adjuster are converted to digital values between 0 to 200 (BCD) and are stored in IR 220 to IR 223.
Analog I/O	Obtaining temperature data, pressure data, etc.	Analog I/O Board	Analog I/O function Analog control also possible when used in combination with PID(--).	Two input points and one output point for analog values (0 to 5 V, 0 to 20 mA, 0 to 10 V)

Purpose		Unit/Board	Function	Details
Serial communications	Changing protocols during operation (e.g., to Host Link via modem)	CPU Unit	STUP(--)	---
	Sending and receiving messages according to the communications protocol of the communications partner	Serial Communications Board	Protocol macro function	---
	Making one-to-one data links with other PCs	CPU Unit or Serial Communications Board	1:1 data link	---
	Sending and receiving data without protocol (no conversion)		No-protocol (TXD(48) and RXD(47))	---
	Sending unsolicited messages to a host computer		PC-initiated communications (TXD(48))	---
	Performing data transfer with PT (Programmable Terminal)		NT Link (1:1 mode or 1:N mode available)	---
Network communications	Making data links (shared data area) via FA network	Controller Link Unit	Data links	---
	Performing message communications (sending and receiving data when necessary) via FA network		Message communications (SEND(90), RECV(98), and CMND(--))	---
	Remote programming or monitoring of another PC on the network via a Host Link or a peripheral bus		Remote programming/monitoring	---
I/O communications	Reducing wiring using high-speed ON/OFF bus in machine	CompoBus/S Master Unit	CompoBus/S Master	Acts as CompoBus/S Master with up to 64 inputs and 64 outputs.
	Machine modularization and reduced wiring using distributed control of CPU Unit through the Master. Conforms to the DeviceNet multivender bus, providing data compatibility with devices from other companies.	CompoBus/D I/O Link Unit	CompoBus/D Slaves	Act as CompoBus/D Slaves with 16 inputs and 16 outputs.
	Reducing wiring Example: Simple communications between PCs, connections between PC robots etc.	B7A Interface Unit	Remote I/O communications	Five types of Unit are available to be used according to the scale of control. Connections possible with B7A Link Terminal at distance of up to 500 m.

Purpose		Unit/Board	Function	Details
Detection sensor input	Reducing wiring and space required for sensor output	Sensor Unit	Input function for Optic Fiber Photoelectric Module, Photoelectric Module with Separate Amplifier and Proximity Module with Separate Amplifier (amplifier function)	Up to four Sensor Modules (amplifier sections) of three kinds of sensor (fiber photoelectric sensor, photoelectric sensor with separable amplifier and proximity sensor with separable amplifier) can be mounted to a single Sensor Unit. Sensor Modules can be selected and combined according to the object to be detected and the distance.
Analog sensor input	Reading analog voltage or current signals from sensors or measuring devices, and outputting analog signals to inverters or analog control devices	Analog Input Unit or Analog Output Unit (Power Supply Unit required)	Analog I/O	Analog input: 4 points (0 to 20 mA, 0 to 5 V, -10 to +10 V) Analog output: 2 points (0 to 20 mA, -10 to +10 V)
	Reading distance data such as level differences and panel thicknesses, by using in combination with displacement sensors	Linear Sensor Interface Unit	Input/operation function for data from linear sensor/amplifier	High-speed, high-precision measurement of voltage or current input from linear (displacement) sensors is performed and the measurements are converted to numeric data for comparative decision processing. Input can be held according to external timing signals. Sampling cycle: 1 ms; External timing sampling time: 0.3 ms
Temperature control functions	Reading data from two temperature controllers with one Unit	Temperature Controller Unit CQM1-TC00□ CQM1-TC10□	Temperature control function	Number of loops: 2 Input: Thermocouple (K, J) or platinum resistance thermometer (Pt, JPt) Output: ON/OFF or advanced PID control (time-proportional) control
	Reading data from two or four temperature controllers with one Unit	Temperature Controller Unit CQM1-TC20□ CQM1-TC30□		Number of loops: 4 or 2 (heater burnout detection function) Input: Thermocouple (K, J, L, T, R, S, B) or platinum resistance thermometer (Pt, JPt) Output: ON/OFF or advanced PID control (time-proportional) control

1-4-1 High-speed Counters

CPU Unit/ Board	Name	No. of counters	Max. counting rate for each input mode				
			Differential Phase	Pulse + Direction	Up/Down	Incrementing	Decrementing
CPU Unit: Input interrupts (Counter Mode)	Input interrupts (Counter Mode)	4	---	---	---	---	1 kHz
CPU Unit: Built-in high-speed counter	High-speed counter 0	1	2.5 kHz	---	---	5 kHz	---
High-speed Counter Board	High-speed counters 1, 2, 3, and 4	4	25 kHz or 250 kHz; multiplication factor: 1/2/4	50 kHz or 500 kHz	50 kHz or 500 kHz	---	---
Pulse I/O Board	High-speed counters 1 and 2	2	25 kHz	50 kHz	50 kHz	---	---

System Configurations Supporting High-speed Counters

System configuration	Unit/Board	Function	Input modes and max. counting rate	No. of counters
Configuration A (13 counters total)	CPU Unit	Decrementing counters for input interrupts (Counter Mode)	Decrementing counter: 1 kHz	4
		High-speed counter 0 for built-in inputs (IR 00004 to IR 00006)	Differential Phase Mode: 2.5 kHz Incrementing Mode: 5 kHz	1
	High-speed Counter Board (mounted in slot 1)	High-speed counters 1, 2, 3 and 4	Differential Phase Mode (multiplication factor: 1/2/4): 25 kHz or 250 kHz, Pulse and Direction Mode, Up/Down Mode: 50 kHz or 500 kHz	4
	High-speed Counter Board (mounted in slot 2)	High-speed counters 1, 2, 3 and 4	Differential Phase Mode (multiplication factor: 1/2/4): 25 kHz or 250 kHz, Pulse and Direction Mode, Up/Down Mode: 50 kHz or 500 kHz	4
Configuration B (11 counters total)	CPU Unit	Decrementing counters for input interrupts (Counter Mode)	Decrementing count: 1 kHz	4
		High-speed counter 0 for built-in inputs (IR 00004 to IR 00006)	Differential Phase Mode: 2.5 kHz Incrementing Mode: 5 kHz	1
	High-speed Counter Board (mounted in slot 1)	High-speed counters 1, 2, 3 and 4	Differential Phase Mode (multiplication factor: 1/2/4): 25 kHz or 250 kHz, Pulse and Direction Mode, Up/Down Mode: 50 kHz or 500 kHz	4
	High-speed Counter Board (mounted in slot 2)	High-speed counters 1 and 2	Differential Phase Mode: 25 kHz Pulse and Direction Mode, Up/Down Mode 50 kHz	2

1-4-2 Pulse Outputs

Unit/Board	Name	No. of pulse output points	Standard pulse output frequency		Variable duty factor pulse output frequency
			Without acceleration/deceleration	With trapezoidal acceleration/deceleration	
Transistor Output Unit	Pulse outputs from an output point	1	20 Hz to 1 kHz	---	---
Pulse Output Board	Pulse outputs from port 1 or 2	2	10 Hz to 50 kHz (20 kHz for a stepping motor)	Acceleration or deceleration only: 0 to 50 kHz Acceleration/deceleration together: 100 Hz to 50 kHz	91.6 Hz, 1.5 kHz, 5.9 kHz

System Configuration Supporting Pulse Outputs

System Configuration	Unit/Board	Function	Output	No. of points
Configuration A (3 outputs total)	CPU Unit	Pulse outputs from Transistor Output Unit output point	Standard pulse output with no acceleration/deceleration: 20 Hz to 1 kHz	1
	Pulse I/O Board (in slot 2)	Pulse outputs 1 and 2	Standard pulse output with no acceleration/deceleration: 10 Hz to 50 kHz Standard pulse output with trapezoidal acceleration/deceleration: 0 Hz to 50 kHz Variable duty-factor pulse output	2

1-5 CQM1-CQM1H Comparison

The differences between the CQM1H and the CQM1 are listed in the following table.

Item	CQM1H	CQM1
Mounting structure	No Backplane (use connectors for mounting)	
Mounting	DIN Track mounting (screw mounting not possible)	
I/O capacity	CQM1H-CPU11/21: 256 points CQM1H-CPU51/61: 512 points	CQM1-CPU11/21-EV1: 128 points CQM1-CPU41/42/43/44/45-EV1: 256 points
Program capacity	CQM1H-CPU11/21: 3.2 Kwords CQM1H-CPU51: 7.2 Kwords CQM1H-CPU61: 15.2 Kwords	CQM1-CPU11/21-EV1: 3.2 Kwords CQM1-CPU41/42/43/44/45-EV1: 7.2 Kwords
Data memory capacity	CQM1H-CPU11/21: 3 Kwords CQM1H-CPU51: 6 Kwords CQM1H-CPU61: 12 Kwords (DM area: 6 Kwords; EM area: 6 Kwords)	CQM1-CPU11/21-EV1: 1 Kword CQM1-CPU41/42/43/44/45-EV1: 6 Kwords
Instruction lengths	1 step per instruction, 1 to 4 words per instruction	
Number of instructions in instruction set	162 (14 basic, 148 special instructions)	CQM1-CPU11/21-EV1: 117 (14 basic, 103 special instructions) CQM1-CPU41/42/43/44/45-EV1: 137 (14 basic, 123 special instructions)
Instruction execution times	LD instruction: 0.375 μ s MOV instruction: 17.6 μ s	LD instruction: 0.5 μ s MOV instruction: 23.5 μ s
Overseeing time	0.70 ms	0.80 ms

Item	CQM1H	CQM1
CPU Unit built-in input points	16 points	
Maximum number of Units (see note)	The number of I/O Units and Dedicated I/O Units that can be connected to a CQM1H CPU Unit is as follows: CPU Block only: 11 Units max. CPU Block and Expansion I/O Block CPU Block: 5 Units max. Expansion I/O Block: 11 Units max.	The number of I/O Units and Dedicated I/O Units that can be connected to a CQM1 CPU Units is as follows: CQM1-CPU11/21-EV1: 7 Units max. (I/O Units only) CQM1-CPU41/42/43/44-EV1: 11 Units max. (I/O Units or Dedicated I/O Units)
Inner Boards	CQM1H-CPU51/61: 2 slots	None
High-speed counters	Supported if CQM1H-CTB41 High-speed Counter Board is mounted.	Not supported

Note When considering the restrictions on the number of connectable Units, an Analog Power Supply Unit must be counted as a Unit, just like I/O or Dedicated I/O Units.

Item	CQM1H	CQM1
Pulse I/O	Supported if CQM1H-PLB2 Pulse I/O Board 1 is mounted.	Supported for CQM1-CPU43-EV1 CPU Unit.
Absolute encoder interface	Supported if CQM1H-ABB21 Absolute Encoder Interface Board is mounted.	Supported for CQM1-CPU44-EV1 CPU Unit.
Analog settings	Supported if CQM1H-AVB41 Analog Setting Board is mounted.	Supported for CQM1-CPU42-EV1 CPU Unit.
Analog I/O	Supported if CQM1H-MAB42 Analog I/O Board is mounted.	Supported for CQM1-CPU45-EV1 CPU Unit.
Protocol macros	Supported if CQM1H-SCB41 Serial Communications Board is mounted.	Not supported
Communications Units	CQM1H-CPU51/61: 1 Unit	None
Controller Link	Supported if CQM1H-CLK21 Controller Link Unit is connected.	Not supported
Peripheral port connections	Connecting cable for personal computer CS1W-CN□□□ Note Connection to personal computer also possible with CQM1-CIF01/02 via CS1W-CN114 Conversion Cable.	CQM1-CIF01/02
	Connecting cable for Programming Console CQM1-PRO01 Programming Console: Use the cable provided with the Console or CS1W-CN114. C200H-PRO27 Programming Console: CS1W-CN224/624 Note Connection to Programming Console also possible with C200H-CN222/422 via CS1W-CN114 Conversion Cable.	CQM1-PRO01 Programming Console: Use the cable provided with the Console. C200H-PRO27 Programming Console: C200H-CN222/422

Item		CQM1H	CQM1	
Interrupts	Input in- terrupts (4 points max.)	Input Interrupt Mode: Interrupts are executed from the CPU Unit's built-in input points (4 points) in response to inputs from external sources.		
		Counter Mode: Interrupts are executed from the CPU Unit's internal built-in input points (4 points) in response to inputs received a certain number of times, counted down.		
	Interval timer in- terrupts (3 points max.)	Scheduled Interrupt Mode: Program is interrupted at regular intervals measured by internal clock.		
		One-shot Interrupt Mode: One interrupt is executed after a certain time, measured by the internal clock.		
	High- speed counter interrupts	Target-value comparison: Interrupts are executed when the high-speed counter PV is equal to a specified value.		
Range Comparison: Interrupts are executed when the high-speed counter PV lies within specified ranges.				
		Counting is possible for high-speed counter input from the CPU Unit's internal input points, Pulse I/O Boards or Absolute Encoder Interface Boards.	Counting is possible for high-speed counter input from the CPU Unit's internal input points and, for the CQM1-CPU43/44-EV1, for input to ports 1 and 2.	
Interrupts from Serial Communications Board	Interrupt subroutines can be called from Serial Communications Board using the interrupt notification function.		Not supported	
I/O bits	CQM1H-CPU11/21: 256 points CQM1H-CPU51/61: 512 points		CQM1-CPU11/21-EV1: 128 points CQM1-CPU41/42/43/44/45-EV1: 256 points	
I/O points for Inner Board slot 1	256 points (16 words) Words used by Inner Board in slot 1: IR 200 to IR 215		None	
I/O points for Inner Board slot 2	192 points (12 words) Words used by Inner Board mounted to slot 2: IR 232 to IR 243		64 points (4 words)	CQM1-CPU43/44-EV1: PVs of high-speed counters 1 and 2 are stored in IR 232 to IR 235. Other CPU Units: IR 232 to IR 235 can be used as work bits.
			64 points (4 words)	CQM1-CPU43-EV1: PVs of pulse outputs are stored in IR 236 to IR 239. Other CPU Units: IR 236 to IR 239 are either used by the system or can be used as work bits.
			96 points (6 words)	CQM1-CPU45-EV1: Analog input conversion values and analog output values are stored in IR 232 to IR 237. Other CPU Units: IR 232 to IR 237 can be used as work bits.
Analog set values	64 points (4 words) Words where analog set values are stored when using the CQM1-AVB41 Analog Setting Board: IR 220 to IR 223		64 points (4 words)	CQM1-CPU42-EV1: Analog set values are stored in IR 220 to IR 223. Other CPU Units: IR 220 to IR 223 can be used as work bits.

Item	CQM1H		CQM1	
DM area	CQM1H-CPU51/61: 6,656 words CQM1H-CPU11/21: 3,584 words	DM area data is accessed (read/write) in word (16-bit) units. Word values are retained when the power is turned OFF or the mode is changed.	CQM1-CPU4□-EV1: 6,656 words CQM1-CPU11/21-EV1: 1,536 words	DM area data is accessed (read/write) in word (16-bit) units only. Word values are retained when the power is turned OFF or the mode is changed.
	Read/write	CQM1H-CPU51/61: DM 0000 to DM 6143 (6,144 words) CQM1H-CPU21/11: DM 0000 to DM 3071 (3,072 words) Can be written by program.	Read/write	CQM1-CPU4□-EV1: DM 0000 to DM 6143 (6,144 words) CQM1-CPU11/21-EV1: DM 0000 to DM 1023 (1,024 words) Can be written by program.
	Read-only	DM 6144 to DM 6568 (425 words) Cannot be written by program.	Read-only	DM 6144 to DM 6568 (425 words) Cannot be written by program.
	Controller Link DM parameter area	CQM1H-CPU51/61: DM 6400 to DM 6409 (11 words) CQM1H-CPU11/21: None	None	---
	Routing table area	CQM1H-CPU51/61: DM 6450 to DM 6499 (50 words) CQM1H-CPU11/21: None	None	---
	Serial Communications Board	CQM1H-CPU51/61: DM 6550 to DM 6559 (10 words) CQM1H-CPU11/21: None	None	---
	Error history area	DM 6569 to DM 6599 (31 words)	Error history area	DM 6569 to DM 6599 (31 words)
	PC Setup	DM 6600 to DM 6655 (56 words)	PC Setup	DM 6600 to DM 6655 (56 words)
EM area	6,144 words	EM area data can be read or written in word (16-bit) units. Contents are retained when the power is turned OFF or the mode is changed. Accessible using instructions from the program or Programming Devices. Read/write words: EM 0000 to EM 6143 (6,144 words)	None	---
Memory Cassette (EEPROM or flash memory)	Mounted from the front of the CPU Unit. Memory Cassettes are used to store and read the user's program, DM (read-only data and PC Setup), and expansion instruction information (as one block of data). It is possible to set the CPU Unit so that when power is turned ON, data stored in the Memory Cassette (user's program, DM, expansion instruction information) is automatically transferred, in one block, to the CPU Unit (auto-boot). Two-way transfer, and comparison of data between the CPU Unit and Memory Cassette is possible using AR area settings.			
	In addition to 4-Kword and 8-Kword EEPROM Memory Cassettes, 15.2-Kword flash memory Memory Cassettes are also available.	4-Kword and 8-Kword EEPROM Memory Cassettes are available.		
Trace memory	1,024 words (trace comparison data: 12 points, 3 words)		CQM1-CPU4□-EV1: 1,024 words (trace comparison data: 12 points, 3 words)	

Item	CQM1H		CQM1	
New instructions	TTIM (TOTALIZING TIMER) instruction, SEND(90)/RECV(98)/CMND(—) (network communications) instructions, PMCR (PROTOCOL MACRO) instruction, STUP(—) (CHANGE RS-232C SETUP) instruction and 19 floating-point math instructions available.		The instructions on the left are not supported by the CQM1.	
Serial communications ports	One built-in peripheral port Supports the following communications: Peripheral bus, Programming Console bus, Host Link, no-protocol			
	One built-in RS-232C port	CQM1H-CPU61/51/21: Supports Host Link, no-protocol, NT Link (1:1 mode) and 1:1 Data Link communications. CQM1H-CPU11: None Note Programming Console functions supported from a PT (except when pin 7 on the DIP switch is OFF).	One built-in RS-232C port	Supports Host Link and no-protocol communications (except CQM1-CPU11/21-EV1). CQM1-CPU4□-EV1 also supports 1:1 Data Link, NT Link (1:1 mode) Note CQM1-CPU4□-EV1 supports Programming Console functions from a PT.
	Serial Communications Board (available separately): 1 RS-232C port and 1 RS-422A/485 port	Host Link, no-protocol, 1:1 Data Link, NT Link (1:1 mode, 1:N mode) and protocol macro communications supported.	None	---
Serial communications modes	No-protocol Up to 256 bytes can be sent or received with special instruction. Header codes and end codes can be set. Transmission delay time setting available.			
	Host Link All of the CPU Unit's I/O memory areas, and the user's program can be accessed using Host Link commands.			
	NT Link (1:1 mode, 1:N mode)	Data transfer is possible without program between the PC and an OMRON PT. The ratio of PCs to PTs can be one-to-one or one-to-many. The 1:N-mode NT Link connections are possible only for the RS-232C port or RS-422A/485 port on the Serial Communications Board.	NT Link (1:1 mode only)	CQM1-CPU4□-EV1 only
Protocol macro	Protocol macro communications supported using the RS-232C port or RS-422A/485 port on the Serial Communications Board (CQM1H-CPU51/61 only). Sending and receiving data is possible using one instruction via a user-defined protocol from the ladder program.	Not supported	---	

Item	CQM1H	CQM1
Power failure detection time	AC power supply: 10 to 25 ms DC power supply: 5 to 25 ms	
Standard accessories	Battery Set: CPM2A-BAT01	Battery Set: C500-BAT08

1-6 Overview Application Procedure

The following procedure outlines the steps necessary to set up, program, and operate a CQM1H control system.

- 1, 2, 3...**
1. Determine the system configuration.

Decide if one or more Inner Boards are required in the system and whether they are to be mounted in the left or right slot. The following boards are available.

 - Serial Communications Board for serial communications.
 - High-speed Counter Board or Pulse I/O Board for high-speed counter inputs.
 - Pulse I/O Board or pulse outputs.
 - Absolute Encoder Interface Board for inputs from an absolute encoder.
 - Analog Setting Board to input settings via variable resistors.
 - Analog I/O Board for analog I/O.

Also, decide if it will be necessary to connect to a Controller Link System.
 2. Allocate I/O.

Nothing is required to allocate I/O with the CQM1H. I/O tables are not required and all I/O is allocated automatically. Words are allocated to I/O Units starting at the CPU Unit and going to the right, with Input Units being allocated words starting at IR 001 and Output Units being allocated words starting at IR 100.
 3. Set settings in the PC Setup.

The PC Setup can be used to control the functions of the CPU Unit and Inner Boards. The default settings in the PC Setup must be confirmed and if any changes are required, they must be made from a Programming Device before starting operation. The PC Setup must be changed to use Inner Boards.
 4. Assemble the PC.
 5. Turn ON the power supply.
 6. Write the ladder program.
 7. Transfer the program to the CPU Unit.
 8. Test operation.

The following steps must be performed in trial operation.

 - a) Check I/O wiring.
 - b) Set the required bits in memory (such as the I/O Hold Bit).
 - c) Monitor operation and debug the system in MONITOR Mode.
 9. Correct the program and return to step 7., above.
 10. Store/print the program.
 11. Begin actual operation.

SECTION 2

Specifications

This section gives specifications for the Units that go together to create a CQM1H PC and provides functional specifications of the memory areas.

- 2-1 Unit Specifications
- 2-1-1 Power Supply Units
- 2-1-2 CPU Unit Specifications
- 2-2 Input Unit Specifications
- 2-2-1 CPU Unit's Built-in 24-V DC Inputs
- 2-2-2 DC Input Units
- 2-2-3 AC Input Units
- 2-3 Output Unit Specifications
- 2-3-1 Contact Output Units
- 2-3-2 Transistor Output Units
- 2-3-3 Triac Output Units

2-1 Unit Specifications

2-1-1 Power Supply Units

Item	CQM1-PA203	CQM1-PA206	CQM1-PA216	CQM1-PD026
Supply voltage	100 to 240 V AC, 50/60 Hz		100 or 230 V AC (selectable), 50/60 Hz	24 V DC
Allowable voltage range	85 to 264 V AC		85 to 132 V AC or 170 to 264 V AC	20 to 28 V DC
Operating frequency range	47 to 63 Hz			---
Power consumption	60 VA max.	120 VA max.		50 W max.
Inrush current	30 A max.			
Output capacity	5 V DC: 3.6 A (18 W)	5 V DC: 6 A 24 V DC: 0.5 A (30 W total)		5 V DC: 6 A (30 W)
Insulation resistance	20 MΩ min. (at 500 V DC) between AC external terminals and GR terminals (see note 1)			20 MΩ min. (at 500 V DC) between AC external terminals and GR terminals (see note 1)
Dielectric strength	2,300 V AC 50/60 Hz for 1 min between AC external and GR terminals, (see note 1) leakage current: 10 mA max. 1,000 V AC 50/60 Hz for 1 min between DC external and GR terminals, (see note 1) leakage current: 20 mA max.			
Noise immunity	Conforms to IEC61000-4-4; 2 kV (power lines)			
Vibration resistance	10 to 57 Hz, 0.075-mm amplitude, 57 to 150 Hz, acceleration: 9.8 m/s ² (see note 2) in X, Y, and Z directions for 80 minutes each (Time coefficient of 8 minutes × coefficient factor of 10 = total time of 80 minutes)			
Shock resistance	147 m/s ² (118 m/s ² for Contact Output Units) 3 times each in X, Y, and Z directions			
Ambient temperature	Operating: 0 to 55 °C Storage: -20 to 75 °C (except battery)			
Humidity	10% to 90% (with no condensation)			
Atmosphere	Must be free from corrosive gases			
Grounding	Less than 100 Ω			
Enclosure rating	Mounted in a panel			
Weight	5 kg max.			
Dimensions (without cables)	187 to 603 × 110 × 107 mm (W×H×D)			

Note 1. Disconnect the LG terminal of the Power Supply Unit from the GR terminal when performing insulation and dielectric strength tests. If the tests are repeatedly performed with the LG and GR terminals short-circuited, the internal components may be damaged.

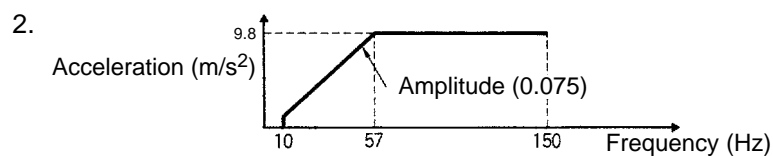

2-1-2 CPU Unit Specifications

Performance Specifications

Item		Specifications
Control method		Stored program method
I/O control method		Cyclic scan and direct output/immediate interrupt processing used together
Programming language		Ladder diagram
I/O capacity		CQM1H-CPU11/21: 256 CQM1H-CPU51/61: 512
Program capacity		CQM1H-CPU11/21: 3.2 Kwords CQM1H-CPU51: 7.2 Kwords CQM1H-CPU61: 15.2 Kwords
Data memory capacity		CQM1H-CPU11/21: 3 Kwords CQM1H-CPU51: 6 Kwords CQM1H-CPU61: 12 Kwords (DM: 6 Kwords; EM: 6 Kwords)
Instruction length		1 to 4 words per instruction
Number of instructions in instruction set		162 (14 basic, 148 special instructions)
Instruction execution times		Basic instructions: 0.375 to 1.125 μ s Special instructions: 17.7 μ s (MOV instruction)
Overseeing time		0.70 ms
Mounting structure		No Backplane (Units are joined horizontally using connectors)
Mounting		DIN Track mounting (screw mounting not possible)
CPU Unit built-in DC input points		16
Maximum number of Units		Maximum number of I/O and Dedication I/O Units (Analog Power Supply Units must also be counted.) CPU Block only: 11 Units max. CPU Block and Expansion I/O Block CPU Block: 5 Units max. Expansion I/O Block: 11 Units max.
Inner Boards		CQM1H-CPU11/21: None CQM1H-CPU51/61: 2 Boards
Communications Units		CQM1H-CPU11/21: None CQM1H-CPU51/61: 1 Unit
Types of interrupts	Input interrupts (4 points max.)	Input Interrupt Mode: Interrupt is executed in response to input from an external source to the CPU Unit's built-in input points. Counter Mode: Interrupt is executed in response to input received a certain number of times (counted down) via the CPU Unit's internal built-in input points (4 points).
	Interval timer interrupts (3 points max.)	Scheduled Interrupt Mode: Program is interrupted at regular intervals measured by one the CPU Unit's internal timers. One-shot Interrupt Mode: One interrupt is executed after a certain time, measured by one of the CPU Unit's internal timers.
	High-speed counter interrupt	Target Value Comparison: Interrupt is executed when the high-speed counter PV is equal to a specified value. Range Comparison: Interrupt is executed when the high-speed counter PV lies within a specified range. Note Counting is possible for high-speed counter inputs from the CPU Unit's internal input points, Pulse I/O Boards, or Absolute Encoder Interface Boards. (The High-speed Counter Board has no interrupt function, and can only output bit patterns internally and externally.)
I/O allocation		I/O is automatically allocated in order from the Unit nearest to the CPU Unit. (Because there are no I/O tables, it is not necessary, and not possible, to create I/O tables from a Programming Device.)

Memory Area Structure

Data area		Size	Words	Bits	Function
IR area (note 1)	Input area	256 bits	IR 000 to IR 015	IR 00000 to IR 01515	Input bits can be allocated to Input Units or I/O Units. The 16 bits in IR 000 are always allocated to the CPU Unit's built-in inputs.
	Output area	256 bits	IR 100 to IR 115	IR 10000 to IR 11515	Output bits can be allocated to Output Units or I/O Units.
	Work areas	2,528 bits min. (note 2)	IR 016 to IR 089	IR 01600 to IR 08915	Work bits do not have any specific function and they can be freely used within the program.
			IR 116 to IR 189	IR 11600 to IR 18915	
IR 216 to IR 219			IR 21600 to IR 21915		
Controller Link status areas	96 bits	IR 090 to IR 095	IR 09000 to IR 09515	Used to indicate the Controller Link data link status information. (Can be used as work bits when a Controller Link Unit is not connected.)	
		IR 190 to IR 195	IR 19000 to IR 19515	Used to indicate the Controller Link error and network participation information. (Can be used as work bits when a Controller Link Unit is not connected.)	
MACRO operand area (note 2)	Input area	64 bits	IR 096 to IR 099	IR 09600 to IR 09915	Used when the MACRO instruction, MCRO(99), is used. (Can be used as work bits when the MACRO instruction is not used.)
	Output area	64 bits	IR 196 to IR 199	IR 19600 to IR 19915	
Inner Board slot 1 area	256 bits	IR 200 to IR 215	IR 20000 to IR 21515	These bits are allocated to the Inner Board mounted in slot 1 of a CQM1H-CPU51/61. (Can be used as work bits when slot 1 is empty.) CQM1H-CTB41 High-speed Counter Board: IR 200 to IR 213 (14 words): Used by the Board IR 214 and IR 215 (2 words): Not used. CQM1H-SCB41 Serial Communications Board: IR 200 to IR 207 (8 words): Used by the Board IR 208 to IR 215 (8 words): Not used.	
Analog settings area (note 1)	64 bits	IR 220 to IR 223	IR 22000 to IR 22315	Used to store the analog settings when a CQM1H-AVB41 Analog Setting Board is mounted. (Can be used as work bits when an Analog Setting Board is not mounted.)	
High-speed Counter 0 PV (note 1)	32 bits	IR 230 to IR 231	IR 23000 to IR 23115	Used to store the present values of high-speed counter 0. (Can be used as work bits when high-speed counter 0 is not being used.)	
Inner Board slot 2 area	192 bits	IR 232 to IR 243	IR 23200 to IR 24315	These bits are allocated to the Inner Board mounted in slot 2. (Can be used as work bits when a CQM1H-CPU11/21 is being used or slot 2 is empty.) CQM1H-CTB41 High-speed Counter Board: IR 232 to IR 243 (12 words): Used by the Board CQM1H-ABB21 Absolute Encoder Interface Board: IR 232 to IR 239 (8 words): Used by the Board IR 240 to IR 243 (4 words): Not used. CQM1H-PLB21 Pulse I/O Board: IR 232 to IR 239 (8 words): Used by the Board IR 240 to IR 243 (4 words): Not used. CQM1H-MAB42 Analog I/O Board: IR 232 to IR 239 (8 words): Used by the Board IR 240 to IR 243 (4 words): Not used.	
SR area	184 bits	SR 244 to SR 255	SR 24400 to SR 25515	These bits serve specific functions such as flags and control bits.	
HR area	1,600 bits	HR 00 to HR 99	HR 0000 to HR 9915	These bits store data and retain their ON/OFF status when power is turned off.	

Data area		Size	Words	Bits	Function
AR area		448 bits	AR 00 to AR 27	AR 0000 to AR 2715	These bits serve specific functions such as flags and control bits.
TR area		8 bits	---	TR 0 to TR 7	These bits are used to temporarily store ON/OFF status at program branches.
LR area (note 1)		1,024 bits	LR 00 to LR 63	LR 0000 to LR 6315	Used for 1:1 data link through the RS-232 port or through a Controller Link Unit.
Timer/Counter area (note 3)		512 bits	TIM/CNT 000 to TIM/CNT 511 (timer/counter numbers)		The same numbers are used for both timers and counters. When TIMH(15) is being used, timer numbers 000 to 015 can be interrupt-refreshed to ensure proper timing during long cycles.
DM area	Read/write	3,072 words	DM 0000 to DM 3071	---	DM area data can be accessed in word units only. Word values are retained when the power is turned off.
		3,072 words	DM 3072 to DM 6143	---	Available in CQM1H-CPU51/61 CPU Units only.
	Read-only (note 4)	425 words	DM 6144 to DM 6568	---	Cannot be written from the program (only from a Programming Device). DM 6400 to DM 6409 (10 words): Controller Link parameters DM 6450 to DM 6499 (50 words): Routing tables DM 6550 to DM 6559 (10 words): Serial Communications Board settings
	Error history area (note 4)	31 words	DM 6569 to DM 6599	---	Used to store the time of occurrence and error code of errors that occur.
	PC Setup (note 4)	56 words	DM 6600 to DM 6655	---	Used to store various parameters that control PC operation.
EM area		6,144 words	EM 0000 to EM 6143	---	EM area data can be accessed in word units only. Word values are retained when the power is turned off. Available in the CQM1H-CPU61 CPU Unit only.

- Note**
1. IR and LR bits that are not used for their allocated functions can be used as work bits.
 2. A minimum of 2,528 bits are available as work bits. Other bits can be used as work bits when they are not used for their allocated functions, so the total number of available work bits depends on the configuration of the PC.
 3. When accessing a PV, TIM/CNT numbers are used as word address; when accessing Completion Flags, they are used as bit addresses.
 4. DM 6144 to DM 6655 cannot be written from the program.

Other Memory Specifications

Item	Details
Memory Cassette (EEPROM or flash memory)	Mounted from the front of the CPU Unit. Memory Cassettes are used to store and read the user's program, DM (read-only DM and PC Setup), and expansion instruction information as one block. It is possible to set the CPU Unit so that when power is turned ON, data stored in the Memory Cassette (user's program, DM, expansion instruction information) is automatically sent to the CPU Unit (auto-boot). Two-way transfer and comparison of data between the CPU Unit and Memory Cassette are possible using AR area control bits.
Trace memory	1,024 words (trace comparison data: 12 points, 3 words)

Function Specifications

Item	Specification
Macro instructions	Subroutines called by instructions containing arguments.
Constant cycle time	1 to 9,999 ms (Unit: 1 ms)
Cycle time monitoring	When the cycle time exceeds 100 ms, the Cycle Time Over Flag turns ON, and operation continues. (A setting can be made in the PC Setup so that this error is not generated.) When the cycle time exceeds the cycle monitor time, operation is stopped. Cycle monitor time settings: 0 to 990 ms in 10-ms units, 0 to 9,990 ms in 100-ms units, 0 to 99 s in 1-s units. Note The maximum and current values of the cycle time are stored in the AR area.
I/O refreshing	Cyclic refreshing, refreshing by IORF(097), direct output refreshing (set in the PC Setup), interrupt input refreshing. (The inputs that are refreshed can be set separately for input interrupts, high-speed counter interrupts, and interval timer interrupts in the PC Setup.)
I/O memory holding when changing operating modes	Depends on the ON/OFF status of the I/O Hold Bit (SR 25212).
Load OFF	All outputs on Output Units can be turned OFF when the CPU Unit is operating in RUN, MONITOR, or PROGRAM mode. (Used for stopping output in emergencies, for debugging, etc.)
User-customized DIP switch setting	A pin setting on the DIP switch on the front of the CPU Unit is stored in AR 0712. This setting can be used as an ON/OFF condition (e.g., to switch between trial operation and actual operation).
Mode setting at power-up	Possible
Debugging	Control set/reset, differential monitoring, data tracing (scheduled, each cycle, or when instruction is executed).
Online editing	User programs can be overwritten in program-block units when the CPU Unit is in MONITOR mode. With the CX-Programmer, more than one program block can be edited at the same time.
Program protection	Write-protection of user program, data memory (DM 6144 to DM 6655: read-only DM), and PC Setup (DM 6600 to DM 6655): Set using pin 1 on the DIP switch.
Error check	User-defined errors (i.e., user can define fatal errors and non-fatal errors using the FAL(06) and FALS(07) instructions.) Note It is possible to stop operation using user-programmed instructions for fatal errors. User-defined error logs can be created in specific bits (logging) when using user-programmed instructions for non-fatal errors.
Error log	Up to 10 errors (including user-defined errors) are stored in the error log. Information includes the error code, error details, and the time the error occurred.
Serial communications ports	Built-in peripheral port: Programming Device (including Programming Console) connections, Host Links, no-protocol communications Built-in RS-232C port: Programming Device (excluding Programming Console) connections, Host Links, no-protocol communications, NT Links (1:1 mode), 1:1 Data Links RS-232C port and RS-422A/485 port on Serial Communications Board (sold separately): Programming Device (excluding Programming Console) connections, Host Links, no-protocol communications, NT Links (1:1 mode, 1:N mode), 1:1 Data Links, protocol macros

Item	Specification			
Serial Communications Modes	CPU Unit built-in ports			Serial Communications Board ports
	Built-in peripheral port	Built-in RS-232C port		
Programming Console bus	Used for communications with Programming Consoles.	Yes (SW7: ON)	No	No
Peripheral bus	Used for communications with Programming Devices such as CX-Programmer.	Yes (SW7: ON)	No	No
Host Link (SYSMAC WAY)	Used to access the CPU Unit's I/O memory and programs using Host Link commands. Supports communications with Programming Devices and OMRON PTs. Communications can be initiated from the CQM1H in this mode.	Yes (SW7: ON)	Yes	Yes
No-protocol	Used for sending or receiving up to 256 bytes of data using special instructions with no protocol or conversion.	Yes (SW7: ON)	Yes	Yes
1:1 Data Link	Used for 1:1 communications via a data link with another CQM1H or with a CQM1, CPM1, C200HX/HG/HE, or C200HS PC.	No	Yes	Yes
NT Link (1:1 mode, 1:N mode)	Used for data exchange with OMRON PTs without program. One-to-one or one-to-many (PC:PT) connections supported. Note The 1:1 mode and 1:N mode are not compatible. Be sure to use the correct communications port at the PT.	No	Yes (1:1 mode only)	Yes (1:1 mode or 1:N mode)
Protocol macro	Used to freely exchange data with general-purpose external devices with a serial port (e.g., RS-232C). Note This mode is supported only by a Serial Communications Board.	No	No	Yes
Clock	Some Memory Cassette are equipped with a clock. Note Used to store the time when errors occur.			
Input time constants	Used to set the ON (or OFF) response times for DC Input Units. Available settings: 1, 2, 4, 8, 16, 32, 64, 128 ms.			
Power OFF detection time	AC power supply: 10 to 25 ms, DC power supply: 5 to 25 ms			
Memory protection	Held Areas: Holding bits, contents of Data Memory and Extended Data Memory, and status of the counter Completion Flags and present values. Note If the I/O Hold Bit (SR 25212) is turned ON, and the PC Setup is set to maintain the I/O Hold Bit status when power to the PC is turned ON, the contents of the IR area and the LR area will be saved.			
Sending commands to a Host Link computer	Host Link command responses can be sent to a computer connected via the Host Link System using the TXD(—) (communications port output) instruction.			
Remote programming and monitoring	Host Link or peripheral bus communications via a CPU Unit's serial communications port can be used for remote programming and remote monitoring of the PC through a Controller Link System. (This function is, however, not supported for the serial communications ports on the Serial Communications Board.)			
Program check	Program checks are performed at the beginning of operation for items such as no END(01) instruction and instruction errors. CX-Programmer can also be used to check programs. (The level of program checking can be set.)			

Item	Specification
Battery life	5 years at 25 °C (Depends on the ambient temperature and power supply conditions. Minimum: 1 year.) Battery replacement must be performed within 5 minutes.
Self-diagnostics	CPU errors (watchdog timer), I/O verification errors, I/O bus errors, memory errors, FALS system errors (FALS instruction execution or cycle monitor time over), FAL system errors (FAL instruction execution or PC Setup error etc.), battery errors, Cycle Time Over errors and communications port errors.
Other functions	Storage of number of times power has been interrupted. (Stored in AR area.)
Internal current consumption	CQM1H-CPU21/51/61: 5 V DC: 840 mA max. CQM1H-CPU11: 5 V DC: 820 mA max.
Dimensions	CQM1H-CPU11/21: 187 to 571 × 110 × 107 mm (W × H × D) CQM1H-CPU51/61: 187 to 603 × 110 × 107 mm (W × H × D)
Standard accessories	One connector for RS-232C port (Except CQM1H-CPU11). Socket: XM2A-0901; Hood: XM2S-0911-E. One CPM2A-BAT01 Battery Set (installed in CPU Unit at time of delivery)

2-2 Input Unit Specifications

2-2-1 CPU Unit's Built-in 24-V DC Inputs

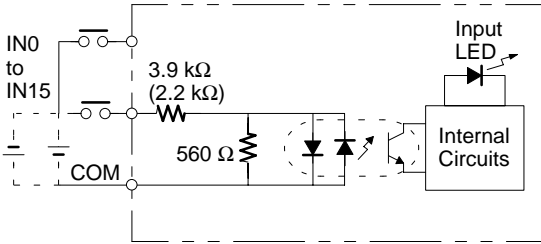
Item	CQM1H-CPU11/21/51/61
Input Voltage	24 V DC +10%/−15%
Input Impedance	IN4 and IN5: 2.2 kΩ; other inputs: 3.9 kΩ
Input Current	IN4 and IN5: 10 mA typical; other inputs: 6 mA typical (at 24 V DC)
ON Voltage	17.4 V DC min.
OFF Voltage	5.0 V DC max.
ON Delay	Default: 8 ms max. (can be set between 1 and 128 ms in PC Setup; see note)
OFF Delay	Default: 8 ms max. (can be set between 1 and 128 ms in PC Setup; see note)
No. of Inputs	16 points (16 inputs/common, 1 circuit)
Circuit Configuration	 <p>The diagram shows a circuit for an input terminal. It includes terminals labeled IN0 to IN15 and a common terminal (COM). A 3.9 kΩ resistor (with 2.2 kΩ in parentheses) is connected between the input terminal and the common terminal. A 560 Ω resistor is connected between the common terminal and the input LED. The input LED is connected to the internal circuits. The input power supply polarity may be connected in either direction.</p> <p>Note Figures in parentheses are for IN4 and IN5. The input power supply polarity may be connected in either direction.</p>

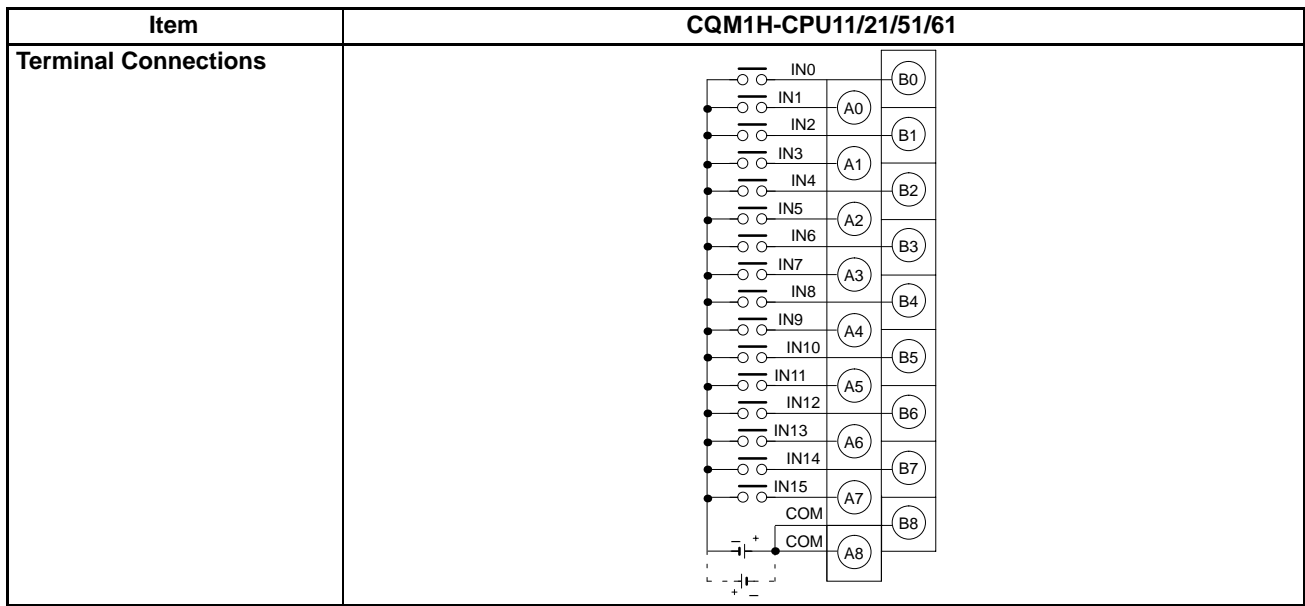

IR 00000 to IR 00015 are always allocated to the CPU Unit's 16 built-in input points.

- Inputs IN0 to IN 3 (corresponding to IR 00000 to IR 00003) can be set in the PC Setup to be used as input interrupts.
- Inputs IN4 to IN7 (corresponding to IR 00004 to 00007) can be used as high-speed counter 0.

Terminal	Input number	Input bit	Function
B0	IN0	IR 00000	Normal inputs or input interrupts (Input Interrupt Mode or Counter Mode): set in PC Setup (DM 6628).
A0	IN1	IR 00001	
B1	IN2	IR 00002	
A1	IN3	IR 00003	
B2	IN4	IR 00004	Normal inputs or high-speed counter 0: set in PC Setup (DM 6642).
A2	IN5	IR 00005	
B3	IN6	IR 00006	
A3	IN7	IR 00007	Only usable as normal inputs.
to	to	to	
B7	IN14	IR 00014	
A7	IN15	IR 00015	

Note If IN0 through IN3 are set for use as input interrupts in the PC Setup, the ON and OFF delays for input interrupts are fixed at 0.1 ms max. and 0.5 ms max., respectively. If IN4 through IN6 are set for use as high-speed counter interrupts, the delays for high-speed counters are as shown in the following table.

Input	Incrementing mode	Differential phase mode
IN4 (A)	5 kHz	2.5 kHz
IN5 (B)	Normal input	
IN6 (Z)	ON: 100 μs min. required; OFF delay: 500 μs min. required	

The minimum response pulses will be as follows:

Input A (IN4), Input B (IN5)

Incrementing Mode (5 kHz max.)

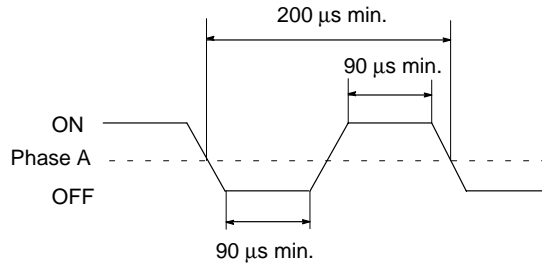

Differential Phase Mode (2.5 kHz max.)

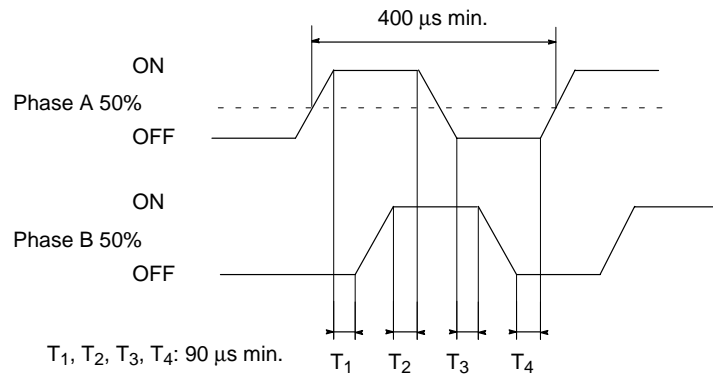

Input Z (IN6)

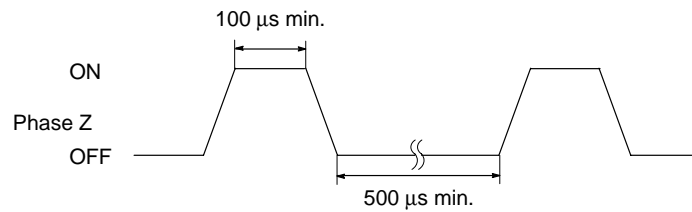

2-2-2 DC Input Units

Item	CQM1-ID211	CQM1-ID212
Name	12 to 24-V DC 8-point Input Unit	24-V DC 16-point Input Unit
Input Voltage	12 to 24 V DC +10%/−15%	24 V DC +10%/−15%
Input Impedance	2.4 kΩ	3.9 kΩ
Input Current	10 mA typical (at 24 V DC)	6 mA typical (at 24 V DC)
ON Voltage	10.2 V DC min.	14.4 V DC min.
OFF Voltage	3.0 V DC max.	5.0 V DC max.
ON Delay	Default: 8 ms max. (can be set between 1 and 128 ms in PC Setup, see note)	Default: 8 ms max. (can be set between 1 and 128 ms in PC Setup, see note)
OFF Delay	Default: 8 ms max. (can be set between 1 and 128 ms in PC Setup, see note)	Default: 8 ms max. (can be set between 1 and 128 ms in PC Setup, see note)
No. of Inputs	8 points (independent commons)	16 points (16 points/common, 1 circuit)
Internal Current Consumption	50 mA max. at 5 V DC	85 mA max. at 5 V DC
Weight	180 grams max.	180 grams max.
Circuit Configuration	<p>Note The input power supply polarity may be connected in either direction.</p>	<p>Note The input power supply polarity may be connected in either direction.</p>
Terminal Connections		

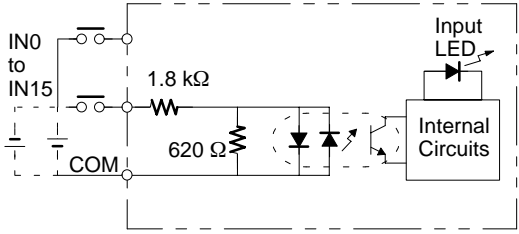
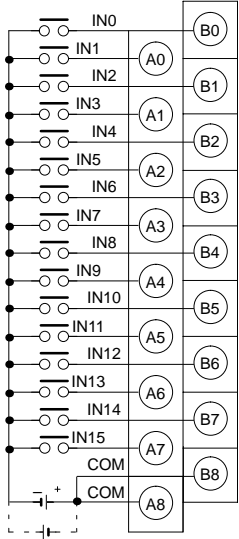
Item	CQM1-ID111
Name	12-V DC 16-point Input Unit
Input Voltage	12 V DC $+10\%/_{-15\%}$
Input Impedance	1.8 k Ω
Input Current	6 mA typical (at 24 V DC)
ON Voltage	8.0 V DC min.
OFF Voltage	3.0 V DC max.
ON Delay	Default: 8 ms max. (can be set between 1 and 128 ms in PC Setup, see note)
OFF Delay	Default: 8 ms max. (can be set between 1 and 128 ms in PC Setup, see note)
No. of Inputs	16 points (16 points/common, 1 circuit)
Internal Current Consumption	85 mA max. at 5 V DC
Weight	180 grams max.
Circuit Configuration	 <p>Note The input power supply polarity may be connected in either direction.</p>
Terminal Connections	

Item	CQM1-ID112
Name	12-V DC 32-point Input Unit
Input Voltage	12 V DC +10%/−15%
Input Impedance	2.2 kΩ
Input Current	4 mA typical (at 12 V DC)
ON Voltage	8.0 V DC min.
OFF Voltage	3.0 V DC max.
ON Delay	Default: 8 ms max. (can be set between 1 and 128 ms in PC Setup)
OFF Delay	Default: 8 ms max. (can be set between 1 and 128 ms in PC Setup)
No. of Inputs	32 points (32 inputs/common, 1 circuit)
Internal current consumption	5 V DC, 170 mA max.
Weight	160 g max.
Circuit Configuration	
Terminal Connections	<p>The polarity of the input power supply can be either plus or minus. The polarity of all the commons, however, must match.</p> <p>The COM terminals are internally connected, but they all must be wired.</p>

Item	CQM1-ID213	CQM1-ID214
Name	24-V DC 32-point Input Unit	24-V DC 32-point Input Unit
Input Voltage	24 V DC +10%/−15%	24 V DC +10%/−15%
Input Impedance	5.6 kΩ	3.9 kΩ
Input Current	4 mA typical (at 24 V DC)	6 mA typical (at 24 V DC)
ON Voltage/Current	14.4 V DC min.	15.4 V DC/3.5 mA min.
OFF Voltage/Current	5.0 V DC max.	5.0 V DC/1 mA max.
ON Delay	Default: 8 ms max. (can be set between 1 and 128 ms in PC Setup)	Default: 8 ms max. (can be set between 1 and 128 ms in PC Setup)
OFF Delay	Default: 8 ms max. (can be set between 1 and 128 ms in PC Setup)	Default: 8 ms max. (can be set between 1 and 128 ms in PC Setup)
No. of Inputs	32 points (32 inputs/common, 1 circuit)	32 points (32 inputs/common, 1 circuit) Number of simultaneously ON inputs is limited by ambient temperature. See diagrams after table.
Internal Current Consumption	5 V DC, 170 mA max.	5 V DC, 170 mA max.
Weight	160 g max.	160 g max.

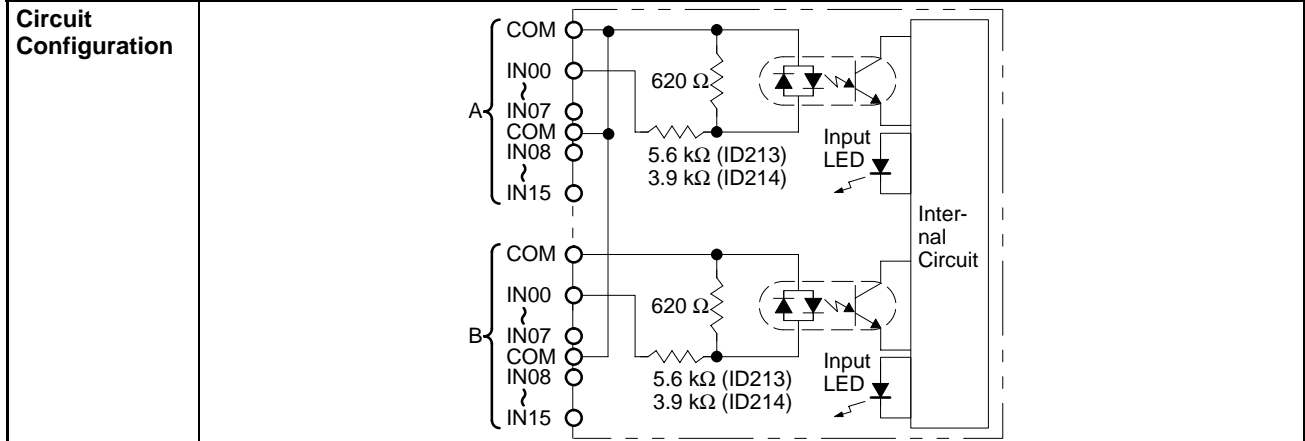

Item	CQM1-ID213	CQM1-ID214
Terminal Connections	<p>The polarity of the input power supply can be either plus or minus. The polarity of all the commons, however, must be the same. The COM terminals are internally connected, but they all must be wired.</p>	<p>The polarity of the input power supply can be either plus or minus. The polarity of all the commons, however, must be the same. The COM terminals are internally connected, but they all must be wired.</p>

Number of Simultaneously ON Inputs for CQM1-ID214

Ambient Temperature for Simultaneously ON Points

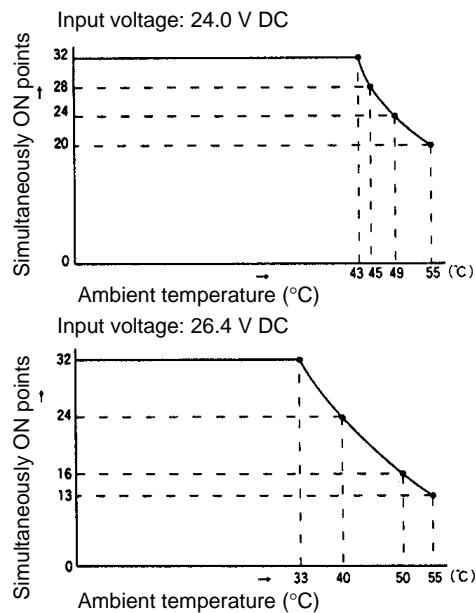

2-2-3 AC Input Units

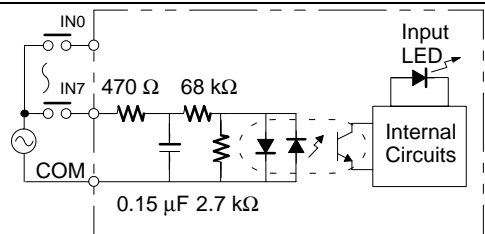
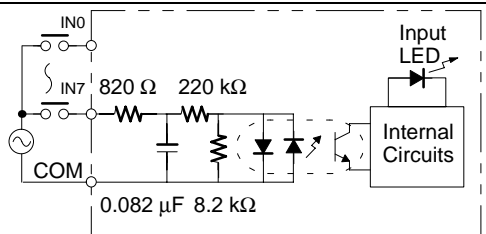
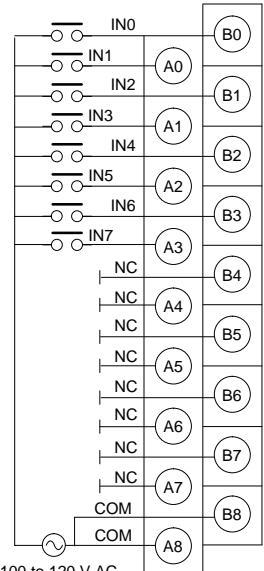
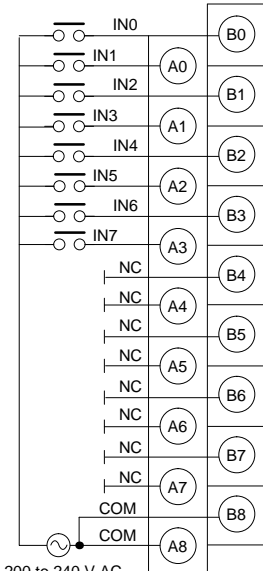
Item	CQM1-IA121	CQM1-IA221
Name	100 to 120-V AC 8-point Input Unit	200 to 240-V AC 8-point Input Unit
Input Voltage	100 to 120 V AC $+10\%/_{-15\%}$, 50/60 Hz	200 to 240 V AC $+10\%/_{-15\%}$, 50/60 Hz
Input Impedance	20 k Ω (50 Hz), 17 k Ω (60 Hz)	38 k Ω (50 Hz), 32 k Ω (60 Hz)
Input Current	5 mA typical (at 100 V AC)	6 mA typical (at 200 V AC)
ON Voltage	60 V AC min.	150 V AC min.
OFF Voltage	20 V AC max.	40 V AC max.
ON Delay	35 ms max.	35 ms max.
OFF Delay	55 ms max.	55 ms max.
No. of Inputs	8 points (8 points/common, 1 circuit)	8 points (8 points/common, 1 circuit)
Internal Current Consumption	50 mA max. at 5 V DC	50 mA max. at 5 V DC
Weight	210 grams max.	210 grams max.
Circuit Configuration	 <p>The polarity of the input power supply can be either plus or minus. The polarity of all the commons, however, must be the same.</p>	 <p>The polarity of the input power supply can be either plus or minus. The polarity of all the commons, however, must be the same.</p>
Terminal Connections	 <p>100 to 120 V AC</p>	 <p>200 to 240 V AC</p>

2-3 Output Unit Specifications

2-3-1 Contact Output Units

Item	CQM1-OC221	CQM1-OC222
Name	8-point Contact Output Unit	16-point Contact Output Unit
Max. Switching Capacity	2 A, 250 V AC ($\cos\phi= 1$) 2 A, 250 V AC ($\cos\phi= 0.4$) 2 A, 24 V DC (16 A/Unit)	2 A, 250 V AC ($\cos\phi= 1$) 2 A, 250 V AC ($\cos\phi= 0.4$) 2 A, 24 V DC (8 A/Unit)
Min. Switching Capacity	10 mA, 5 V DC	10 mA, 5 V DC
Relay	G6D-1A	G6D-1A
Service Life of Relay	Electrical: 300,000 operations (resistive load) 100,000 operations (inductive load) Mechanical: 20,000,000 operations (See note.)	Electrical: 300,000 operations (resistive load) 100,000 operations (inductive load) Mechanical: 20,000,000 operations (See note.)
ON Delay	10 ms max.	10 ms max.
OFF Delay	5 ms max.	5 ms max.
No. of Outputs	8 points (independent commons)	16 points (16 points/common, 1 circuit))
Internal Current Consumption	430 mA max. at 5 V DC	850 mA max. at 5 V DC
Weight	200 grams max.	230 grams max.
Circuit Configuration		
Terminal Connections		

Note The values for relay service life in the above table represent the minimum values. The following chart gives reference values for the actual service life.

Relay Service Life for CQM1-OC221/222

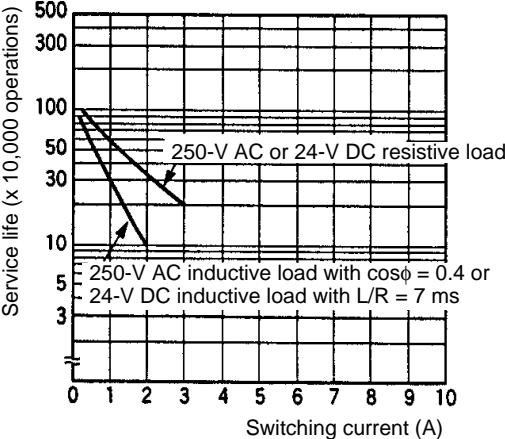

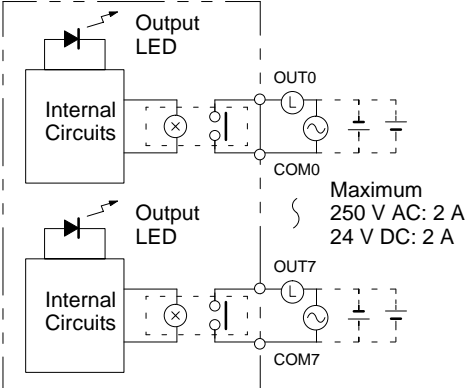
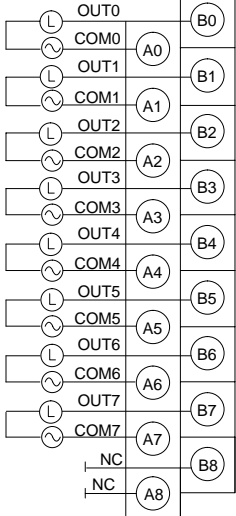
Item	CQM1-OC224
Name	8-point Contact Output Unit
Max. Switching Capacity	2 A, 250 V AC ($\cos\phi=1$) 2 A, 250 V AC ($\cos\phi=0.4$) 2 A, 24 V DC (16 A/Unit)
Min. Switching Capacity	10 mA, 5 V DC
Relay	G6R-1A or G6RN-1A
Service Life of Relay	Electrical: 300,000 operations Mechanical: 10,000,000 operations (See note.)
ON Delay	15 ms max.
OFF Delay	5 ms max.
No. of Outputs	8 points (independent commons)
Internal Current Consumption	440 mA max. at 5 V DC
Weight	270 grams max.
Circuit Configuration	
Terminal Connections	

Note The values for relay service life in the above table represent the minimum values. The following chart gives reference values for the actual service life.

Relay Service Life for CQM1-OC224

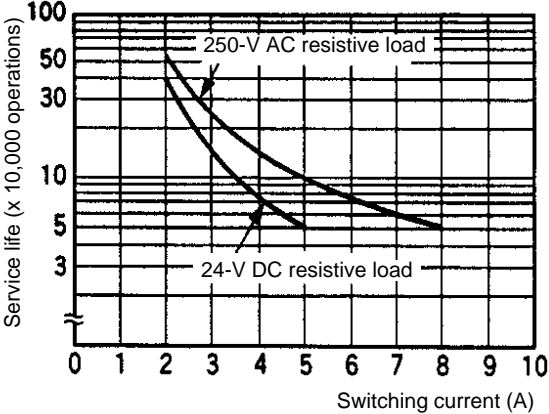

2-3-2 Transistor Output Units

Item	CQM1-OD211																																																									
Name	8-point Transistor Output Unit																																																									
Max. Switching Capacity	2 A at 24 V DC $+10\%/_{-15\%}$ 5 A/Unit																																																									
Leakage Current	0.1 mA max.																																																									
Residual Voltage	0.7 V max.																																																									
ON Delay	0.1 ms max.																																																									
OFF Delay	0.3 ms max.																																																									
No. of Outputs	8 points (8 points/common, 1 circuit)																																																									
Internal Current Consumption	90 mA max. at 5 V DC max.																																																									
Fuse	7 A (one per common), one used Fuse is not user replaceable.																																																									
Service Power Supply	15 mA min. at 24 V DC $+10\%/_{-15\%}$ (1.9 mA \times number of ON points)																																																									
Weight	200 grams max.																																																									
Circuit Configuration																																																										
Terminal Connections	<table border="1" style="display: inline-table; vertical-align: top;"> <tr><td>OUT0</td><td>(A0)</td><td>(B0)</td></tr> <tr><td>OUT1</td><td>(A1)</td><td>(B1)</td></tr> <tr><td>OUT2</td><td>(A2)</td><td>(B2)</td></tr> <tr><td>OUT3</td><td>(A3)</td><td>(B3)</td></tr> <tr><td>OUT4</td><td>(A4)</td><td>(B4)</td></tr> <tr><td>OUT5</td><td>(A5)</td><td>(B5)</td></tr> <tr><td>OUT6</td><td>(A6)</td><td>(B6)</td></tr> <tr><td>OUT7</td><td>(A7)</td><td>(B7)</td></tr> <tr><td>NC</td><td>(A8)</td><td>(B8)</td></tr> <tr><td>NC</td><td></td><td></td></tr> <tr><td>NC</td><td></td><td></td></tr> <tr><td>NC</td><td></td><td></td></tr> <tr><td>NC</td><td></td><td></td></tr> <tr><td>NC</td><td></td><td></td></tr> <tr><td>NC</td><td></td><td></td></tr> <tr><td>NC</td><td></td><td></td></tr> <tr><td>NC</td><td></td><td></td></tr> <tr><td>+DC</td><td></td><td></td></tr> <tr><td>COM</td><td></td><td></td></tr> </table> <p>Note</p> <ol style="list-style-type: none"> 1. Do not reverse the polarity of the load power supply. If the load power supply is connected incorrectly, the loads may not operate correctly. 2. Do not reverse the connections for +DC and the common. If +DC and the common are connected incorrectly, internal circuits may be damaged. 	OUT0	(A0)	(B0)	OUT1	(A1)	(B1)	OUT2	(A2)	(B2)	OUT3	(A3)	(B3)	OUT4	(A4)	(B4)	OUT5	(A5)	(B5)	OUT6	(A6)	(B6)	OUT7	(A7)	(B7)	NC	(A8)	(B8)	NC			NC			NC			NC			NC			NC			NC			NC			+DC			COM		
OUT0	(A0)	(B0)																																																								
OUT1	(A1)	(B1)																																																								
OUT2	(A2)	(B2)																																																								
OUT3	(A3)	(B3)																																																								
OUT4	(A4)	(B4)																																																								
OUT5	(A5)	(B5)																																																								
OUT6	(A6)	(B6)																																																								
OUT7	(A7)	(B7)																																																								
NC	(A8)	(B8)																																																								
NC																																																										
NC																																																										
NC																																																										
NC																																																										
NC																																																										
NC																																																										
NC																																																										
NC																																																										
+DC																																																										
COM																																																										

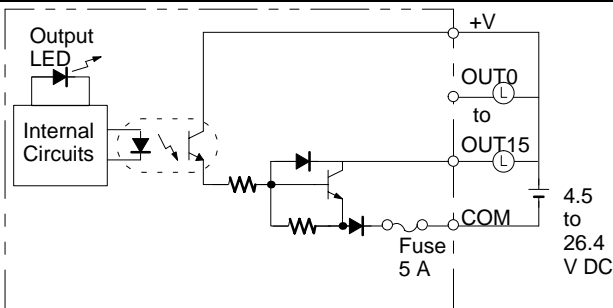
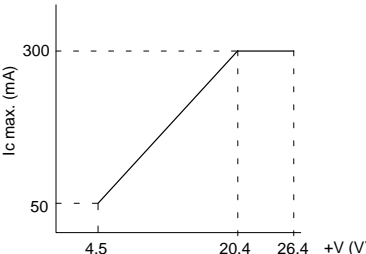
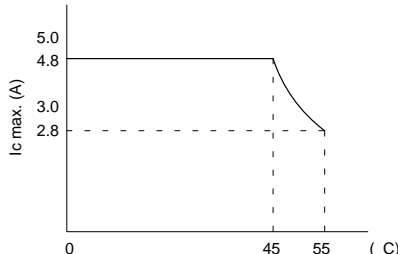
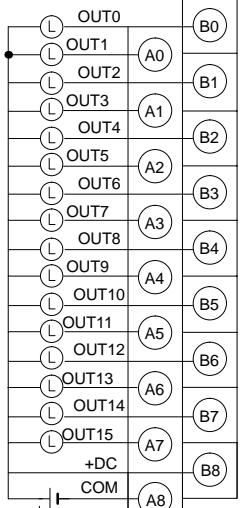
Item	CQM1-OD212
Name	16-point Transistor Output Unit
Max. Switching Capacity	50 mA at 4.5 V DC to 300 mA at 26.4 V (see diagram below)
Leakage Current	0.1 mA max.
Residual Voltage	0.8 V max.
ON Delay	0.1 ms max.
OFF Delay	0.4 ms max.
No. of Outputs	16 points (16 points/common, 1 circuit)
Internal Current Consumption	170 mA max. at 5 V DC
Fuse	5 A (one per common), one used Fuse is not user replaceable.
Service Power Supply	40 mA min. at 5 to 24 V DC $\pm 10\%$ (2.5 mA \times number of ON points)
Weight	180 grams max.
Circuit Configuration	 <p>Max. Switch Capacity (per Point)</p>  <p>Max. Switch Capacity (Total for Unit)</p> 
Terminal Connections	

Item	CQM1-OD213
Name	32-point Transistor Output Unit
Max. Switching Capacity	16 mA at 4.5 V DC to 100 mA at 26.4 V (see diagram below)
Leakage Current	0.1 mA max.
Residual Voltage	0.8 V max.
ON Delay	0.1 ms max.
OFF Delay	0.4 ms max.
No. of Outputs	32 points (32 points/common, 1 circuit)
Internal Current Consumption	240 mA max. at 5 V DC
Fuse	3.5 A (one per common), one used Fuse is not user replaceable.
Service Power Supply	110 mA min. at 5 to 24 V DC $\pm 10\%$ (3.4 mA \times number of ON points)
Weight	180 grams max.

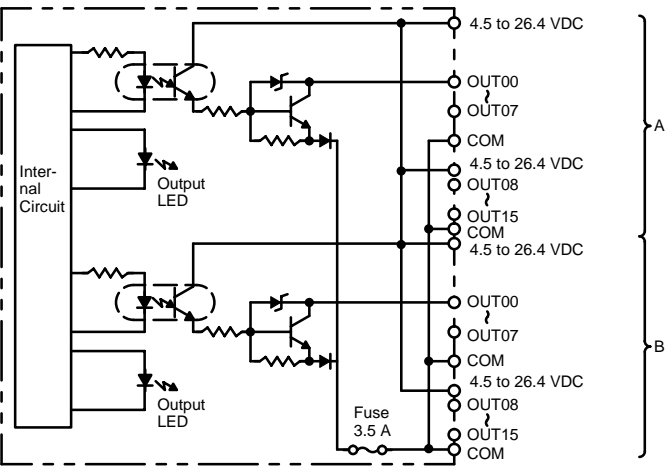
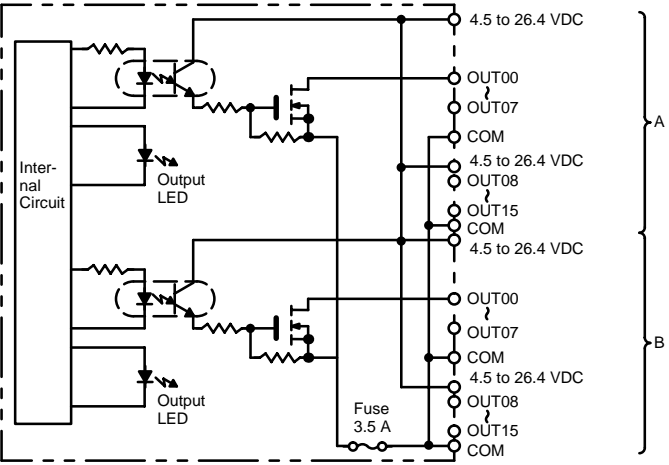
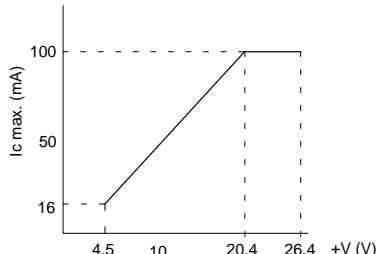
Item	CQM1-OD213
Circuit Configuration	<p>Units manufactured on or before December 28th, 1999 (manufacturing numbers 28Z9 or earlier)</p>  <p>Units manufactured on or after January 5th, 2000 (manufacturing numbers 0510 or later)</p>  <p>Max. Switch Capacity (per Point)</p> 

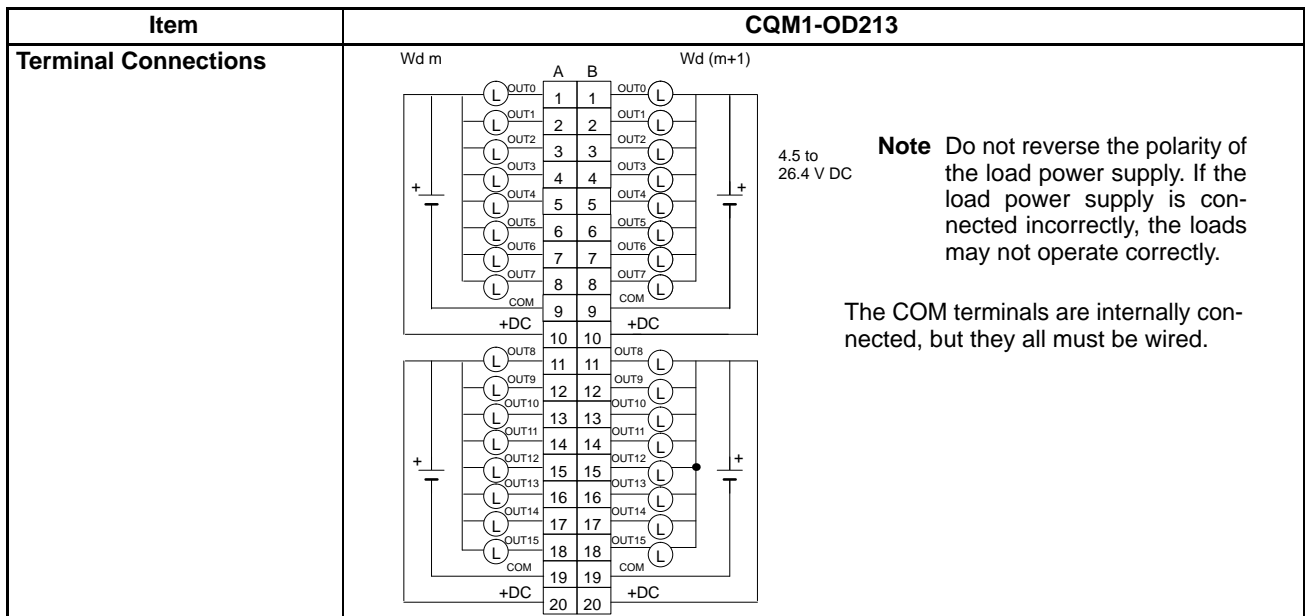

Details of Changes

Output elements have been changed from NPN transistors to field-effect transistors (FET). Part of the circuit configuration has been changed. There are no changes in performance characteristics as a result of these improvements.

Manufacturing Numbers

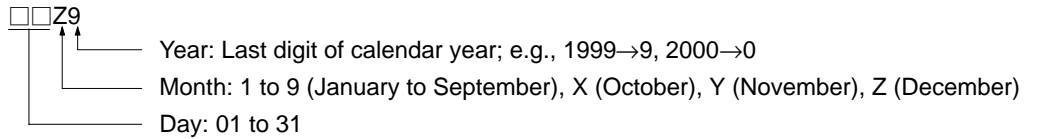

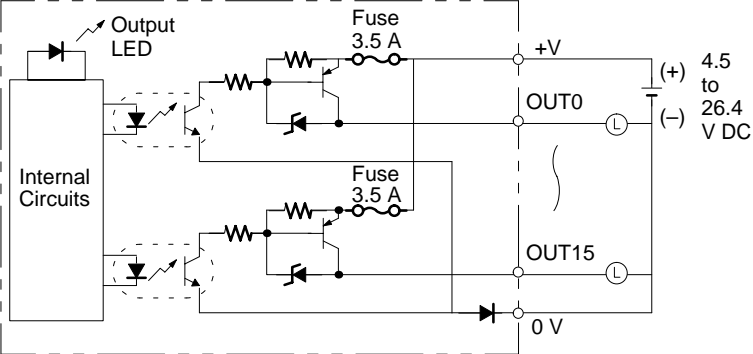
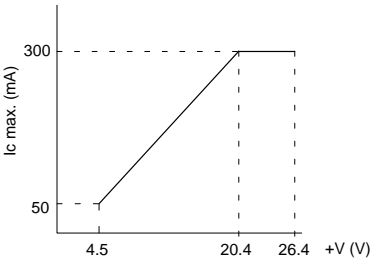
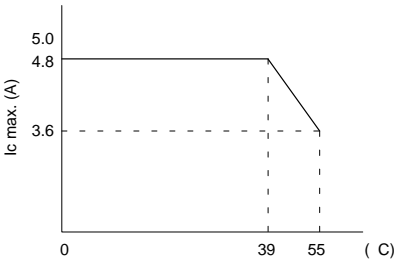
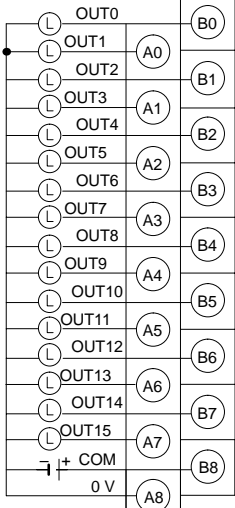
Item	CQM1-OD214																																						
Name	16-point PNP Transistor Output Unit																																						
Max. Switching Capacity	50 mA at 4.5 V DC to 300 mA at 26.4 V (see diagram below)																																						
Leakage Current	0.1 mA max.																																						
Residual Voltage	0.8 V max.																																						
ON Delay	0.1 ms max.																																						
OFF Delay	0.4 ms max.																																						
No. of Outputs	16 points (16 points/common, 1 circuit)																																						
Internal Current Consumption	170 mA max. at 5 V DC																																						
Fuse	3.5 A (one per common), two used. Fuse is not user replaceable.																																						
Service Power Supply	60 mA min. at 5 to 24 V DC $\pm 10\%$ (3.5 mA \times number of ON points)																																						
Weight	210 grams max.																																						
Circuit Configuration	 <p>Max. Switch Capacity (per Point)</p>  <table border="1"> <caption>Max. Switch Capacity (per Point)</caption> <thead> <tr> <th>+V (V)</th> <th>Ic max (mA)</th> </tr> </thead> <tbody> <tr> <td>4.5</td> <td>50</td> </tr> <tr> <td>20.4</td> <td>300</td> </tr> <tr> <td>26.4</td> <td>300</td> </tr> </tbody> </table> <p>Max. Switch Capacity (Total for Unit)</p>  <table border="1"> <caption>Max. Switch Capacity (Total for Unit)</caption> <thead> <tr> <th>+V (V)</th> <th>Ic max (A)</th> </tr> </thead> <tbody> <tr> <td>0</td> <td>4.8</td> </tr> <tr> <td>39</td> <td>4.8</td> </tr> <tr> <td>55</td> <td>3.6</td> </tr> </tbody> </table>	+V (V)	Ic max (mA)	4.5	50	20.4	300	26.4	300	+V (V)	Ic max (A)	0	4.8	39	4.8	55	3.6																						
+V (V)	Ic max (mA)																																						
4.5	50																																						
20.4	300																																						
26.4	300																																						
+V (V)	Ic max (A)																																						
0	4.8																																						
39	4.8																																						
55	3.6																																						
Terminal Connections	 <table border="1"> <thead> <tr> <th>Output</th> <th>Terminal Block Pin</th> </tr> </thead> <tbody> <tr><td>OUT0</td><td>B0</td></tr> <tr><td>OUT1</td><td>A0</td></tr> <tr><td>OUT2</td><td>B1</td></tr> <tr><td>OUT3</td><td>A1</td></tr> <tr><td>OUT4</td><td>B2</td></tr> <tr><td>OUT5</td><td>A2</td></tr> <tr><td>OUT6</td><td>B3</td></tr> <tr><td>OUT7</td><td>A3</td></tr> <tr><td>OUT8</td><td>B4</td></tr> <tr><td>OUT9</td><td>A4</td></tr> <tr><td>OUT10</td><td>B5</td></tr> <tr><td>OUT11</td><td>A5</td></tr> <tr><td>OUT12</td><td>B6</td></tr> <tr><td>OUT13</td><td>A6</td></tr> <tr><td>OUT14</td><td>B7</td></tr> <tr><td>OUT15</td><td>A7</td></tr> <tr><td>COM</td><td>B8</td></tr> <tr><td>0 V</td><td>A8</td></tr> </tbody> </table>	Output	Terminal Block Pin	OUT0	B0	OUT1	A0	OUT2	B1	OUT3	A1	OUT4	B2	OUT5	A2	OUT6	B3	OUT7	A3	OUT8	B4	OUT9	A4	OUT10	B5	OUT11	A5	OUT12	B6	OUT13	A6	OUT14	B7	OUT15	A7	COM	B8	0 V	A8
Output	Terminal Block Pin																																						
OUT0	B0																																						
OUT1	A0																																						
OUT2	B1																																						
OUT3	A1																																						
OUT4	B2																																						
OUT5	A2																																						
OUT6	B3																																						
OUT7	A3																																						
OUT8	B4																																						
OUT9	A4																																						
OUT10	B5																																						
OUT11	A5																																						
OUT12	B6																																						
OUT13	A6																																						
OUT14	B7																																						
OUT15	A7																																						
COM	B8																																						
0 V	A8																																						

Item	CQM1-OD215	
Name	8-point PNP Transistor Output Unit	
Max. Switching Capacity	1.0 A at 24 V DC $+10\%/_{-15\%}$ 4 A/Unit	
Leakage Current	0.1 mA max.	
Residual Voltage	1.2 V max.	
ON Delay	0.2 ms max.	
OFF Delay	0.8 ms max.	
No. of Outputs	8 points (8 points/common, 1 circuit)	
Internal Current Consumption	110 mA max. at 5 V DC max.	
Service Power Supply	24 mA min. at 24 V DC $+10\%/_{-15\%}$ (3 mA \times number of ON points)	
Weight	240 grams max.	
Alarm Output	No. of outputs	2 outputs ALM0: Alarm output OUT 0 to 3 ALM1: Alarm output OUT 4 to 7
	Output specifications	Max. switching capacity: 100 mA at 24 V DC $+10\%/_{-15\%}$ Leakage current: 0.1 mA max. Residual voltage: 0.7 V max.
Reset Input	No. of inputs	2 inputs RST0: Reset input OUT 0 to 3 RST1: Reset input OUT 4 to 7
	Input specifications	Input voltage: 24 V DC $+10\%/_{-15\%}$ Input current: 7 mA, typical (24 V DC) ON voltage: 16.0 V DC min. OFF voltage: 5.0 V DC max.
Short-circuit Protection (see note)	Detection current: 2 A (minimum value), 1.6 A (typical)	
Circuit Configuration		

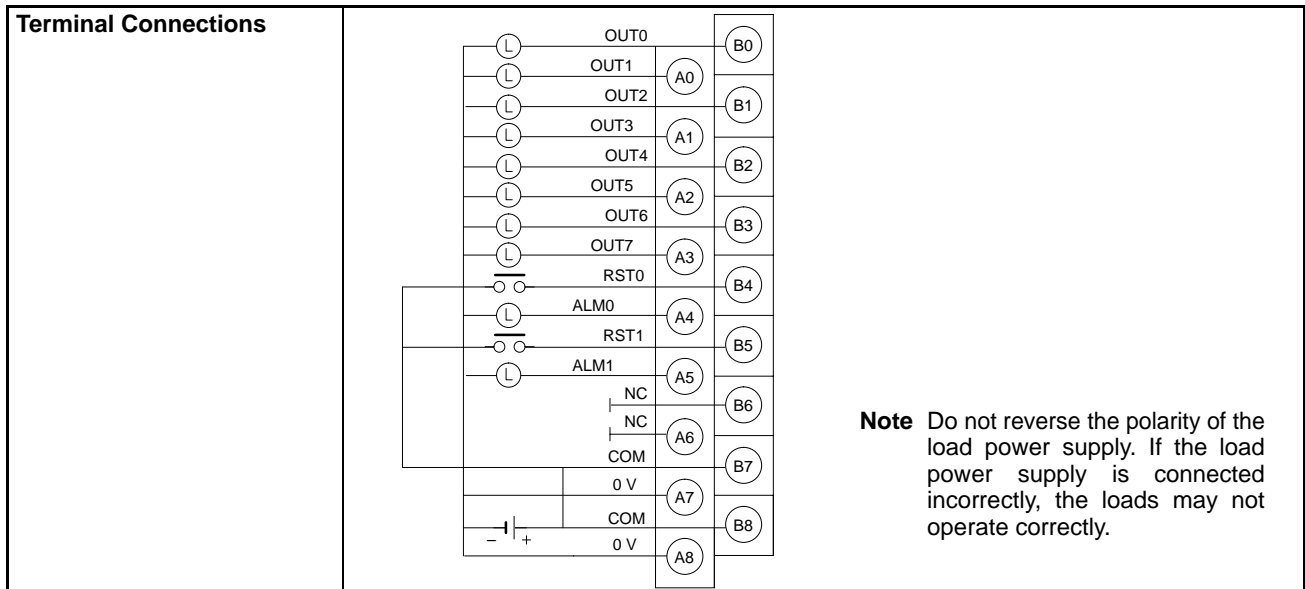

Note If the output current of any output exceeds the detection current, the outputs will be turned OFF at the four points (OUT0 to 3 or OUT4 to 7) which include that output. At the same time, the alarm output (ALM0 or ALM 1) will turn ON and the alarm indicator will light.

If an alarm output turns ON, first eliminate the problem that caused the detection current to be exceeded. Then turn from ON to OFF the reset input (RST0 or RST1) on the side where the alarm output turned ON. The alarm output indicator will then turn off, the alarm output will return to OFF, and the contact's output will be restored.

Item	CQM1-OD216	
Name	32-point PNP Transistor Output Unit	
Max. Switching Capacity	0.5 A at 24 V DC ^{+10%} / _{-15%} 5 A/Unit	
Leakage Current	0.1 mA max.	
Residual Voltage	0.8 V max.	
ON Delay	0.1 ms max.	
OFF Delay	0.3 ms max.	
No. of Outputs	32 points (32 points/common, 1 circuit)	
Internal Current Consumption	240 mA max. at 5 V DC max.	
Fuse	7 A (one per common), one used Fuse is not user replaceable.	
Service Power Supply	160 mA min. at 24 V DC ^{+10%} / _{-15%} (5 mA × number of ON points)	
Weight	210 grams max.	
Alarm Output	No. of outputs	1 output (PNP): Turns ON when output short-circuit or overcurrent is detected.
	Output specifications	Max. switching capacity: 50 mA at 24 V DC ^{+10%} / _{-15%} Leakage current: 0.1 mA max. Residual voltage: 0.8 V max.
Short-circuit Protection (see note)	Detection current: 0.7 to 2.5 A (Operation restored automatically after error cleared.)	
Circuit Configuration	<p>The diagram illustrates the internal circuit configuration of the 32-point PNP Transistor Output Unit. It shows two main sections, A and B, each containing 16 outputs (OUT00-OUT15) and an ALM (Alarm output). The outputs are connected to a common (+V) line through PNP transistors. A 7-A fuse is connected to the common (+V) line. Short-circuit protection circuits are shown for each output, and an Output LED is connected to each output. Internal Circuits are also shown, including a common (+V) line and a 0V line.</p>	

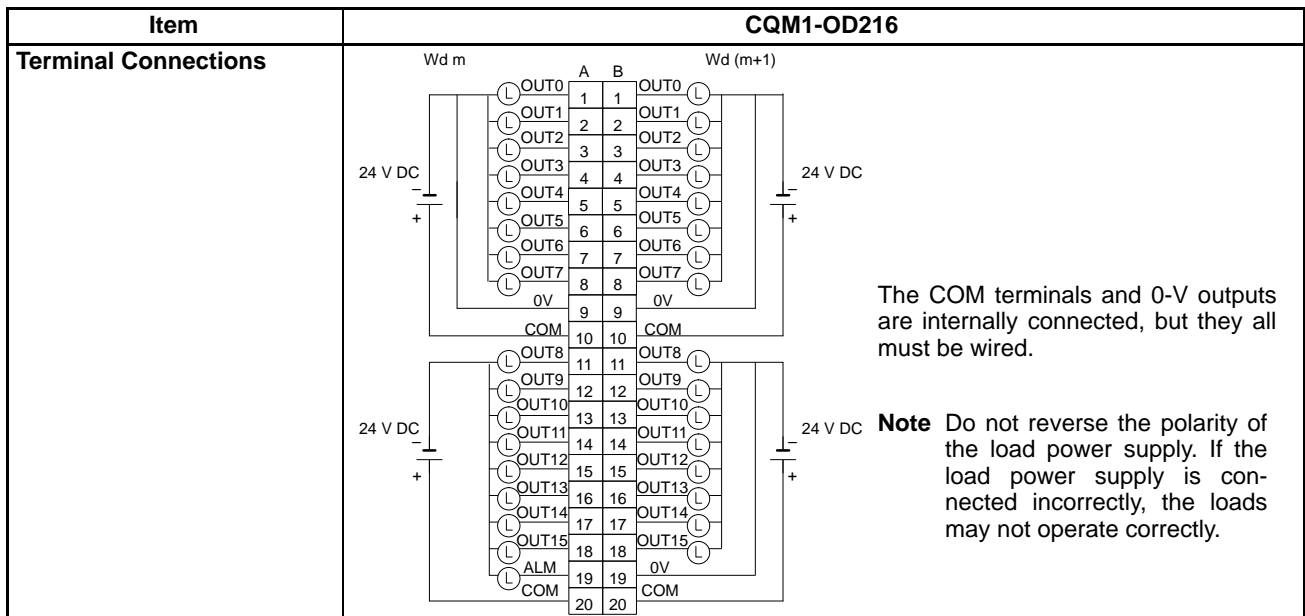

Note If the output current of any output exceeds the detection current, the output will be turned OFF. At the same time, the alarm output (ALM) will turn ON (Low).
 If an alarm output turns ON, eliminate the problem that caused the detection current to be exceeded. The internal temperature of the element will drop and the alarm will automatically be cleared.

2-3-3 Triac Output Units

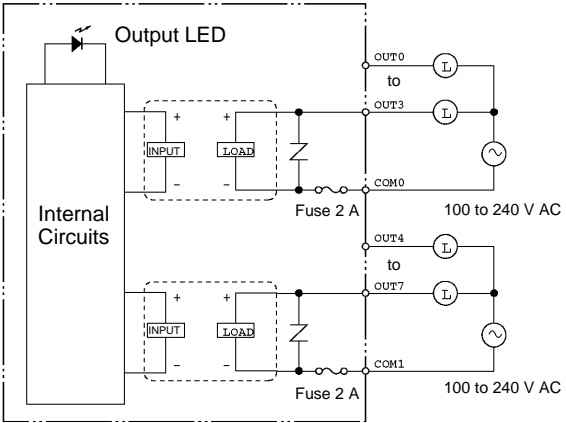
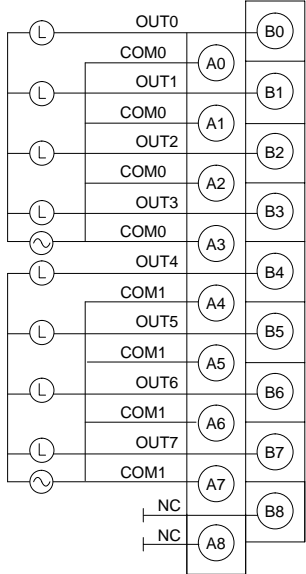
Item	CQM1-OA221
Name	8-point Triac Output Unit
Max. Switching Capacity	0.4 A at 100 to 240 V AC
Leakage Current	1 mA max. at 100 V AC and 2 mA max. at 200 V AC
Residual Voltage	1.5 V max. (0.4 A)
ON Delay	6 ms max.
OFF Delay	1/2 cycle + 5 ms max.
No. of Outputs	8 points (4 points/common, 2 circuits)
Internal Current Consumption	110 mA max. at 5 V DC
Fuse	2 A (one per common), two used. Fuse is not user replaceable.
Weight	240 grams max.
Circuit Configuration	 <p>The diagram illustrates the internal circuitry of the triac output unit. It features two parallel AC output stages. Each stage consists of a common terminal (COM0 and COM1) and two output points (OUT0-OUT3 and OUT4-OUT7). The common terminals are connected to a 100 to 240 V AC supply through a 2 A fuse. Each output point is connected to a load (L) and an output LED. The internal circuits are powered by an input (INPUT) and a load (LOAD).</p>
Terminal Connections	 <p>The terminal connection diagram shows the following connections:</p> <ul style="list-style-type: none"> OUT0 to A0 and B0 OUT1 to A1 and B1 OUT2 to A2 and B2 OUT3 to A3 and B3 OUT4 to A4 and B4 OUT5 to A5 and B5 OUT6 to A6 and B6 OUT7 to A7 and B7 COM0 to A0, A1, A2, A3 COM1 to A4, A5, A6, A7 NC to A8 NC to B8 <p>COM0 and COM1 are not connected internally.</p>

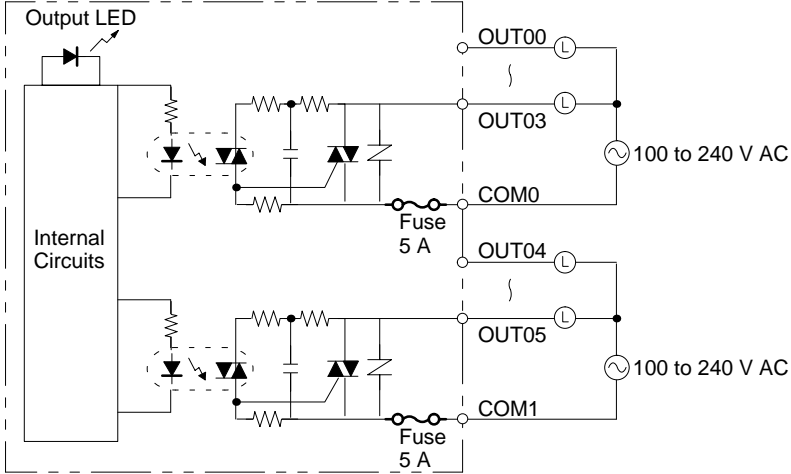
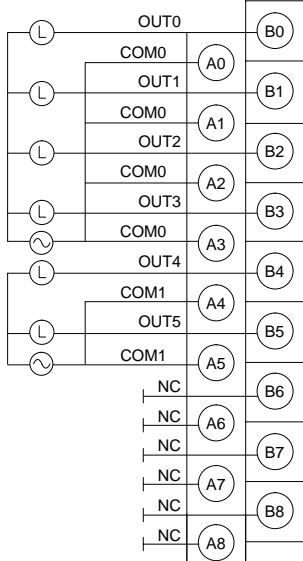
Item	CQM1-OA222
Name	6-point Triac Output Unit
Max. Switching Capacity	0.4 A at 100 to 240 V AC (50/60 Hz)
Min. Switching Capacity	100 mA at 10 V AC 50 mA at 24 V AC 10 mA at 100 V AC 10 mA at 240 V AC
Leakage Current	1 mA max. at 100 V AC and 2 mA max. at 200 V AC
Residual Voltage	1.5 V max. (0.4 A)
ON Delay	1 ms max.
OFF Delay	Load frequency of 1/2 cycle + 1 ms max.
No. of Outputs	6 points (4 points/common, 1 circuit; 2 points/common, 1 circuit)
Inrush current	6 A at 100 ms 15 A at 10 ms
Internal Current Consumption	250 mA max. at 5 V DC
Fuse	5 A at 250 V (one per common), two used. Fuse is not user replaceable.
Weight	240 grams max.
Circuit Configuration	 <p>The diagram illustrates the internal circuit configuration of the CQM1-OA222. It shows two independent AC output channels. Each channel consists of a common terminal (COM0 and COM1) and two output terminals (OUT0-OUT3 and OUT4-OUT5). The outputs are controlled by triac drivers, each with an associated fuse (5 A). An Output LED is shown connected to the internal circuits.</p>
Terminal Connections	 <p>The terminal connection diagram shows the physical layout of the terminals. On the left, there are two columns of terminals labeled A0 through A8. On the right, there are two columns of terminals labeled B0 through B8. The connections are as follows:</p> <ul style="list-style-type: none"> OUT0 is connected to A0 and B0. COM0 is connected to A1 and B1. OUT1 is connected to A2 and B2. COM0 is connected to A3 and B3. OUT2 is connected to A4 and B4. COM1 is connected to A5 and B5. OUT3 is connected to A6 and B6. COM1 is connected to A7 and B7. OUT4 is connected to A8 and B8. OUT5 is connected to A9 and B9. COM1 is connected to A10 and B10. NC (Not Connected) terminals are shown for A11-A14 and B11-B14. <p>COM0 and COM1 are not connected internally.</p>

SECTION 3

Units

This section provides details on functions and nomenclature for the Units that make up the CQM1H and provides information on Programming Devices and communications specifications.

- 3-1 CPU Units
- 3-1-1 Indicators
- 3-1-2 Battery Compartment Cover
- 3-1-3 Battery
- 3-1-4 DIP Switch
- 3-1-5 Memory Cassettes
- 3-1-6 Serial Communications Ports
- 3-1-7 Peripheral Port
- 3-1-8 Built-in RS-232C Port
- 3-1-9 Inner Board Slots 1 and 2
- 3-1-10 Built-in Inputs
- 3-2 Power Supply Unit
- 3-2-1 Power Supply Unit Components
- 3-2-2 Selecting a Power Supply Unit
- 3-2-3 Unit Weights
- 3-3 I/O Units
- 3-4 Inner Boards
- 3-5 Products for Expansion I/O Blocks
- 3-6 Programming Devices
- 3-6-1 Programming Consoles
- 3-6-2 Support Software

3-1 CPU Units

There are four different CPU Units. These are listed in the following table. The four models can be thought of in two groups: Those which support Inner Boards and a Communications Unit, and those that do not. There are also differences between the CPU Units in program capacity, I/O capacity, the availability of EM, and the availability of a built-in RS-232C port.

Model number	I/O capacity (points, see note)	Program capacity (Kwords)	CPU Unit built-in input points	DM capacity (Kwords)	EM capacity (Kwords)	Built-in serial communications ports		Inner Boards	Communications Unit
						Peripheral port	RS-232C port		
CQM1H-CPU61	512	15.2	DC: 16	6	6	YES	YES	Supported	Supported
CQM1H-CPU51		7.2		6	None				
CQM1H-CPU21	256	3.2		3	No				
CQM1H-CPU11									

Note I/O capacity = No. of input points (≤ 256) + No. of output points (≤ 256).

CPU Unit Components

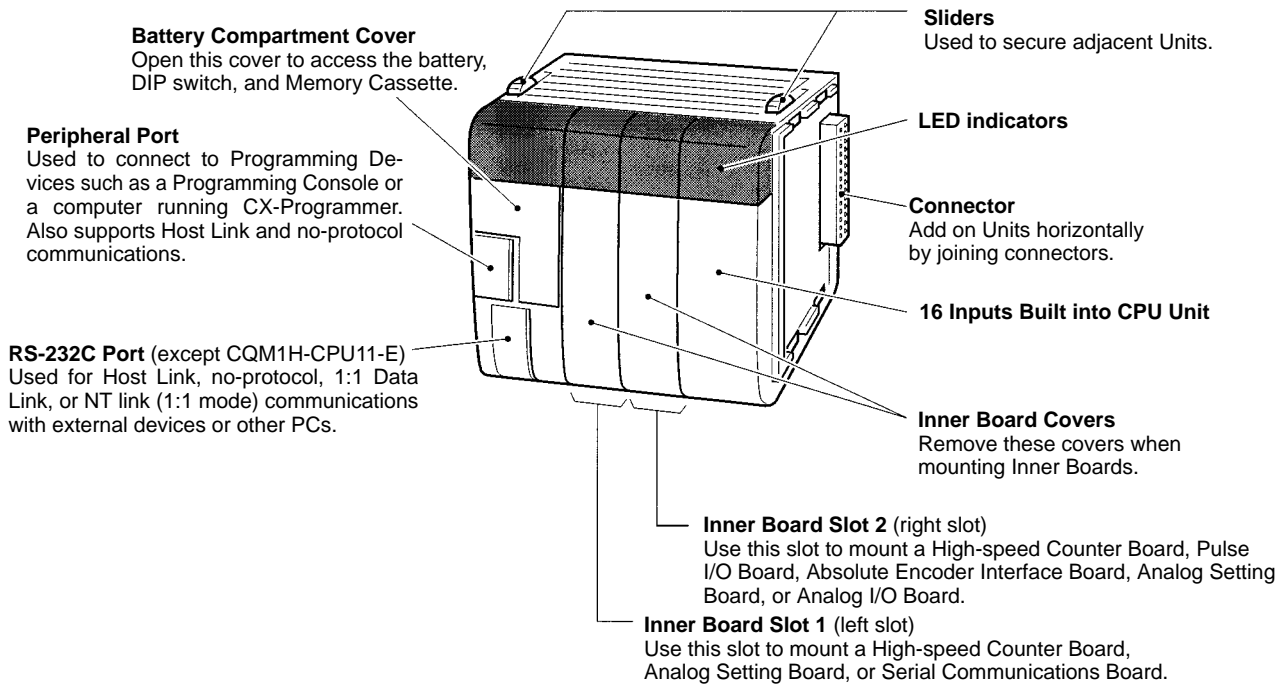

3-1-1 Indicators

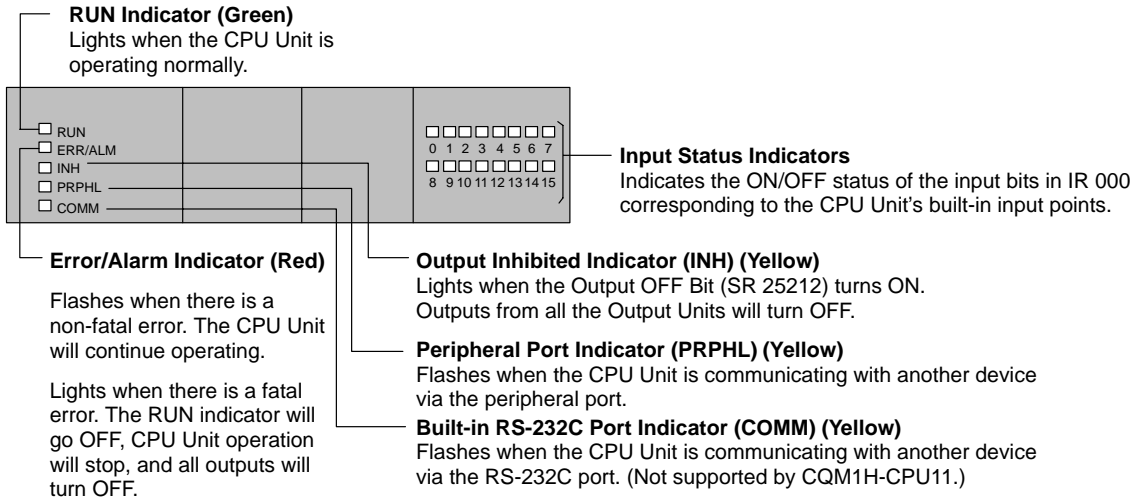

Indicator	Color	Status	Meaning
RUN	Green	Lit	PC is operating normally in MONITOR or RUN mode.
		Not lit	PC has stopped operating while in PROGRAM mode, or has stopped operating due to a fatal error.
ERR/ALM	Red	Lit	A fatal error has occurred. The CPU Unit will stop operating, and the outputs from all Output Units will turn OFF.
		Flash	A non-fatal error has occurred. The CPU Unit will continue operating.
		Not lit	CPU Unit is operating normally or a watchdog timer error has occurred.
INH	Yellow	Lit	Output OFF Bit (SR 25212) has been turned ON. The outputs from all Output Units will turn OFF.
		Not lit	Output OFF Bit (SR 25212) is OFF.
PRPHL	Yellow	Lit	CPU Unit is sending or receiving via the peripheral port.
		Not lit	CPU Unit is not communicating via the peripheral port.
COMM	Yellow	Lit	CPU Unit is sending or receiving via the built-in RS-232C port.
		Not lit	CPU Unit is not communicating via the built-in RS-232C port.

3-1-2 Battery Compartment Cover

To open the battery compartment cover, insert your fingertip or a small screwdriver in the gap at the bottom of the cover and open upwards.

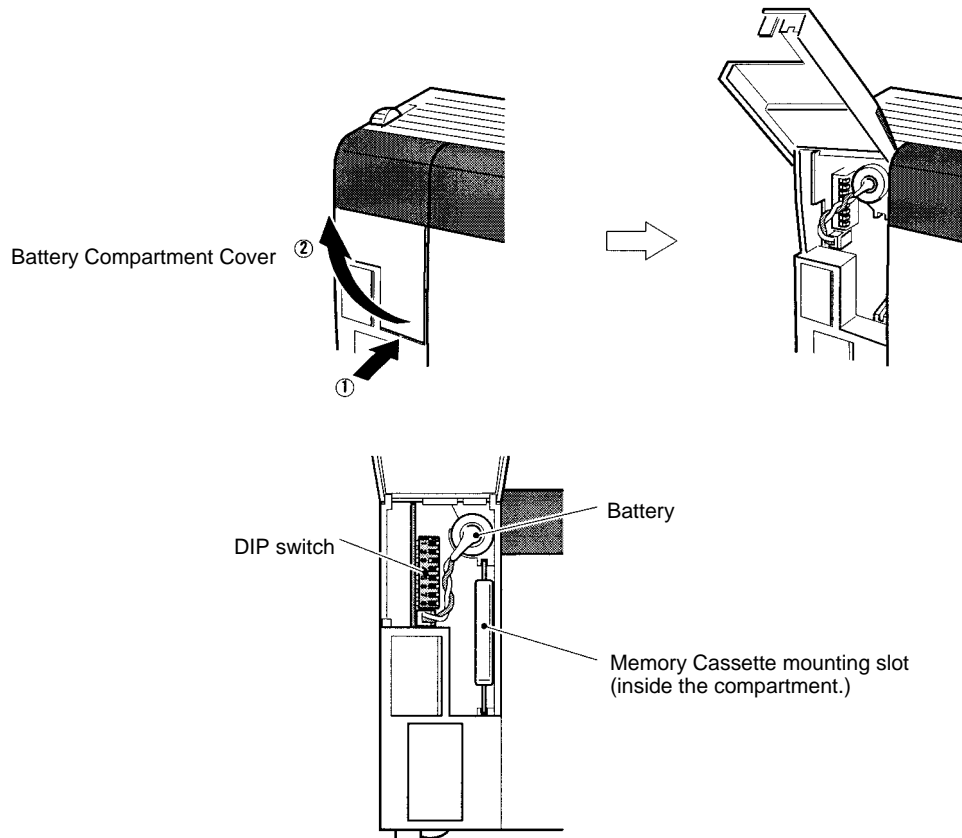

3-1-3 Battery

The CPU Unit has an internal battery. The following data is backed up using the battery.

- I/O memory (including PC Setup)
- User program
- Clock data (when a Memory Cassette with a clock is mounted)

The battery life at an ambient temperature of 25°C is 5 years. When the battery expires, the ERR/ALM indicator on the front of the CPU Unit will light. Replace with a new battery within one week.

Replacement Battery Set

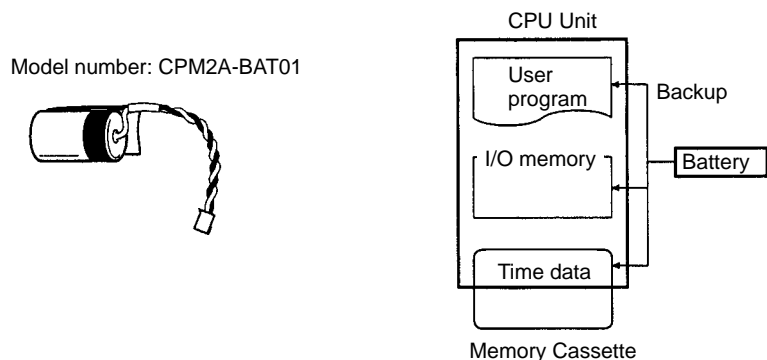

Note Do not remove the battery except when replacing it. If the battery is not replaced within 5 minutes after removal, internal data may be lost. For details on the replacement method, refer to 6-2 *Battery Replacement*.

3-1-4 DIP Switch

The DIP switch is used to set the following: Memory write protection, auto-transfer of data from Memory Cassette, the Programming Console display language, the expansion instruction setting, communications settings, a user-determined setting, and the device connected to peripheral port.

Refer to 6-1 *DIP Switch Settings* for details.

3-1-5 Memory Cassettes

A Memory Cassette can be mounted in the CPU Unit to transfer or compare the following data between the CPU Unit and the Memory Cassette.

- User program
- Data memory
(Read-only DM: DM 6144 to DM 6568; PC Setup: DM 6600 to DM 6655)
- Expansion instruction information

It is not necessary to specify the areas to be read or written. All the data is transferred in one batch. A Memory Cassette must be purchased separately.

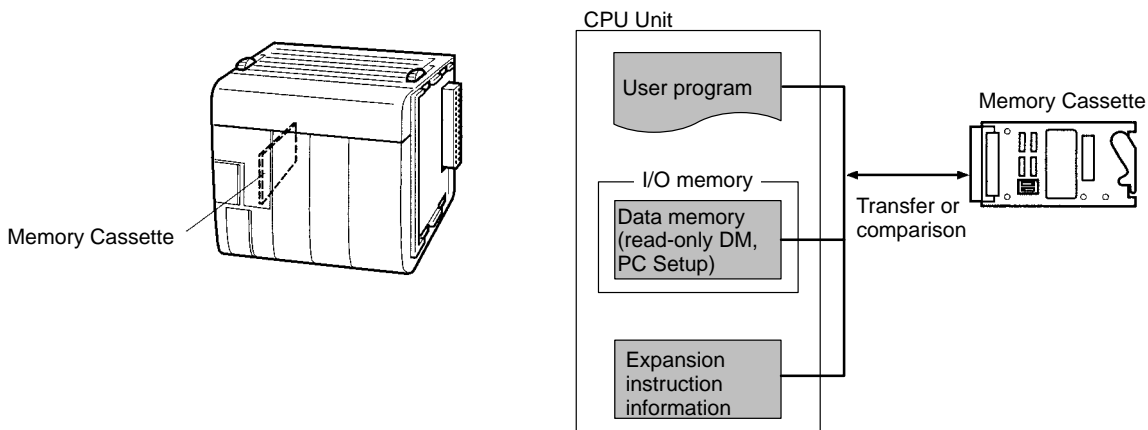

Memory Cassette Types

There are three types of Memory Cassette: EEPROM, EPROM, and Flash Memory. The models of Memory Cassette that are available are listed in the following tables.

Memory	Model	Specifications
EEPROM ¹	CQM1-ME04K	4 Kwords without clock
	CQM1-ME04R	4 Kwords with clock
	CQM1-ME08K	8 Kwords without clock
	CQM1-ME08R	8 Kwords with clock
EPROM ²	CQM1-MP08K	8 Kwords, 16 Kwords, or 32 Kwords without clock
	CQM1-MP08R	8 Kwords, 16 Kwords, or 32 Kwords with clock
Flash ^{1, 3}	CQM1H-ME16K	16 Kwords without clock
	CQM1H-ME16R	16 Kwords with clock

- Note**
1. Data can be read and written for an EEPROM Memory Cassette with a Programming Device.
 2. Data can be read from a EPROM Memory Cassette with a Programming Device, but must be written with a PROM Writer.
 3. The CQM1H-ME16K and CQM1H-ME16R cannot be used in CQM1 PCs.

4. The effective life of the EEPROM and flash memory is 50,000 writes. Data may become unstable if the memory is used after exceeding the effective life.

Mounting EPROM Chips

One of the following EPROM Chips must be purchased separately and mounted to a EPROM Memory Cassette.

Model	ROM version	Capacity	Access speed
ROM-ID-B	27128 or equivalent	8 Kwords	150 ns
ROM-JD-B	27256 or equivalent	16 Kwords	150 ns
ROM-KD-B	27512 or equivalent	32 Kwords	150 ns

Before mounting the EPROM Chip, set the switches on the Memory Cassette according to the type of Chip.

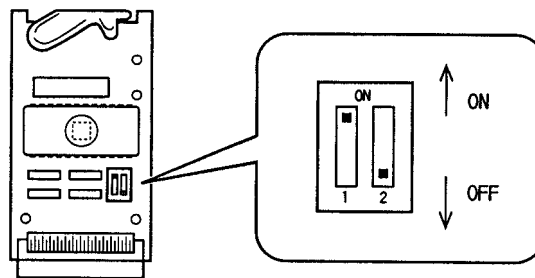

The switches are set as follows:

EPROM type	SW1	SW2
27128	Off	Off
27256	ON	Off
27512	ON	ON

Mount the EPROM Chip to the EPROM Memory Cassette as shown below. Align the notch in the EEPROM Chip with the notch on the socket on the Memory Cassette.

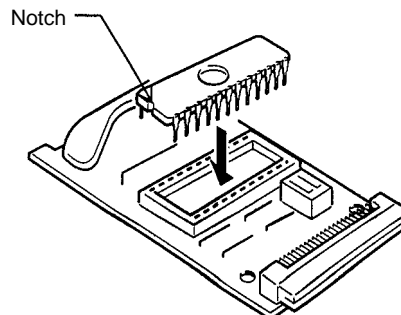

Write-protecting EEPROM or Flash Memory Cassettes

EEPROM Memory Cassettes

EEPROM Memory Cassettes have a write-protect switch that can be used to prevent data on the Cassette from being deleted or overwritten. The switch is

shown in the following diagram. Turn ON the switch to write-protect the Cassette. Turn OFF the switch to write data.

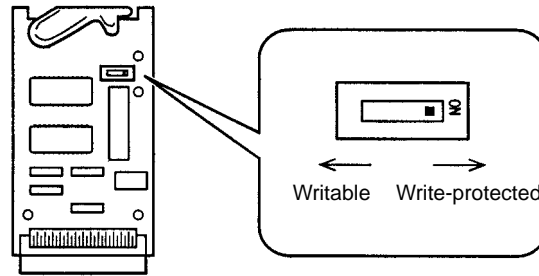

- Note**
1. Turn OFF power to the CQM1H and remove the Memory Cassette to change the switch setting.
 2. AR 1302 will be ON when the Memory Cassette is write-protected.
 3. The effective life of the EEPROM is 50,000 writes. Data may become unstable if the memory is used after exceeding the effective life.

Flash Memory Cassettes

Flash Memory Cassettes have a write-protect switch that can be used to prevent data on the Cassette from being deleted or overwritten. The switch is shown in the following diagram. Turn ON the switch to write-protect the Cassette. Turn OFF the switch to write data.

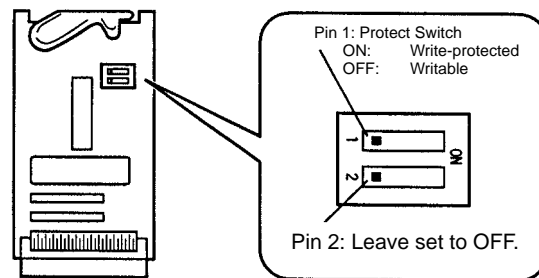

- Note**
1. Turn OFF power to the CQM1H and remove the Memory Cassette to change the switch setting.
 2. AR 1302 will be ON when the Memory Cassette is write-protected.
 3. The effective life of the flash memory is 50,000 writes. Data may become unstable if the memory is used after exceeding the effective life.

Mounting a Memory Cassette

Slide the Memory Cassette into the grooves and press in until it engages with the connector inside the CPU Unit, as shown in the following diagram. Close the cover when finished.

- Note**
1. Always turn OFF power to the CQM1H before mounting or removing a Memory Cassette.
 2. Do not remove the battery. If the battery is removed for more than 5 minutes, data in the CPU Unit may be lost.

3. Do not leave the cover open during operation.

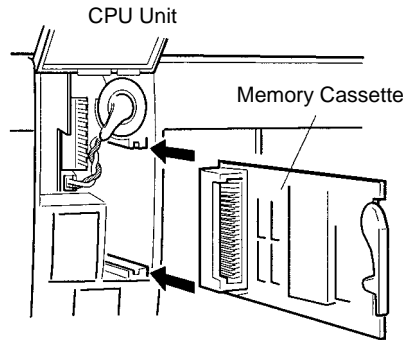

Transferring and Comparing Data

There are two methods to read/write and compare data between a Memory Cassette and the CPU Unit: AR area control bits/flag and automatic transfer at start-up. Refer to the *CQM1H Programming Manual* for details.

AR Area Control Bits and Flag

- AR 1400: Turn ON to write data from the CPU Unit to the Memory Cassette.
- AR 1401: Turn ON to read data from the Memory Cassette to the CPU Unit.
- AR 1402: Turn ON to compare contents of the CPU Unit and Memory Cassette.
- AR 1403: Turns ON when comparison shows the CPU Unit and Memory Cassette to contain different data.

Automatic Transfer at Startup (auto-boot)

If pin 2 on the DIP switch on the front of the CPU Unit is ON, Memory Cassette data will be automatically transferred to the CPU Unit at startup.

3-1-6 Serial Communications Ports

Peripheral Port
(Under the cover)
Usually used for Programming Devices. Communications with Programming Consoles are supported via this port only.

Built-in RS-232C Port
(Not on CQM1H-CPU11)
Usually used for devices other than Programming Devices. Communications with Programming Consoles and peripheral bus communications are not supported via this port.

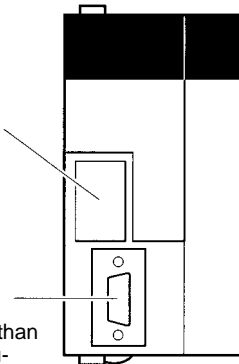

Serial Communications Modes and Ports

Device and mode	Peripheral port	Built-in RS-232C port
Programming Console in Programming Console Bus Mode	Yes (Pin 7: OFF)	No
Programming Device running on personal computer in Peripheral Bus Mode	Yes (Pin 7: ON)	No
Host computer or PT in Host Link Mode	Yes (Pin 7: ON)	Yes
General-purpose external device in No-protocol Mode	Yes (Pin 7: ON)	Yes
C-series PC in 1:1 Data Link Mode	No	Yes
PT in 1:1 NT Link Mode	No	Yes

3-1-7 Peripheral Port

The peripheral port is mainly used for connecting Programming Devices, such as Programming Consoles and personal computers running Support Software.

Programming Consoles can be connected only to this port. Host Link and no-protocol communications are also supported for this port.

- Note**
1. When connecting a Programming Console to the peripheral port, turn OFF pin 7 on the DIP switch on the front of the CPU Unit.
 2. When connecting a device to the peripheral port other than a Programming Console, such as a personal computer running Support Software, be sure to turn ON pin 7 on the DIP switch on the front of the CPU Unit. When connecting to a peripheral bus, it is also necessary to set the communications mode in the PC Setup to Host Link mode.

Opening the Peripheral Port Cover

Insert your fingertip or a small screwdriver in the gap on the right of the cover and pull to the left to open, as shown on the left in the following illustration.

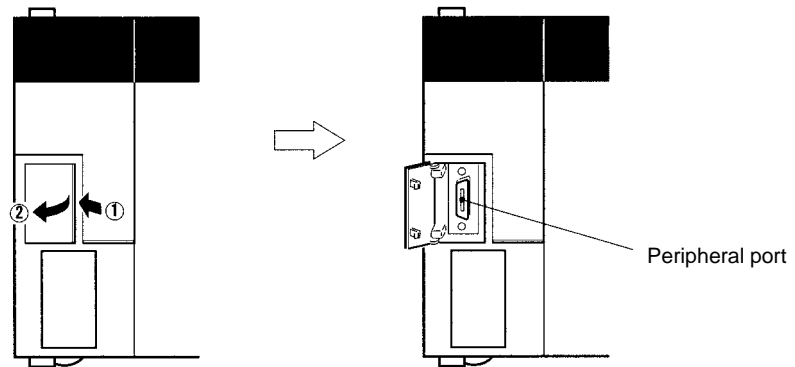

3-1-8 Built-in RS-232C Port

The RS-232C port built into the CPU Unit is mainly used for connecting devices other than Programming Devices. It is not possible to perform communications with a Programming Console or any other Programming Device via a peripheral bus using this port. The following communications modes are supported: Host Link, no-protocol, 1:1 Data Link, and 1:1-mode NT link.

Connector Pin Assignments

Pin assignments for the RS-232C port are given in the following table.

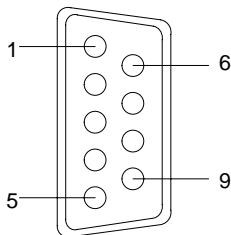

Pin	Abbreviation	Name	Direction
1	FG	Field ground	---
2	SD (TXD)	Send data	Output
3	RD (RXD)	Receive data	Input
4	RS (RTS)	Request to send	Output
5	CS (CTS)	Clear to send	Input
6	+5V (see note)	Power supply	---
7	---	Not used.	---
8	---	Not used.	---
9	SG	Signal ground	---
Connector fitting	FG	Field ground	---

Note The 5-V power supply connected via pin 6 is only for the NT-AL001 RS-232C/RS-422S Converting Link Adapter.

Port Specifications

Item	Specification
Communications method	Half duplex
Sync	Start-stop
Baud rate	1,200, 2,400, 4,800, 9,600, or 19,200 bps
Transmission method	Point to point
Transmission distance	15 m max.
Interface	EIA RS-232C

Connecting to a Computer

The CPU Unit can be connected to an IBM PC/AT or compatible computer via the RS-232C port as shown below.

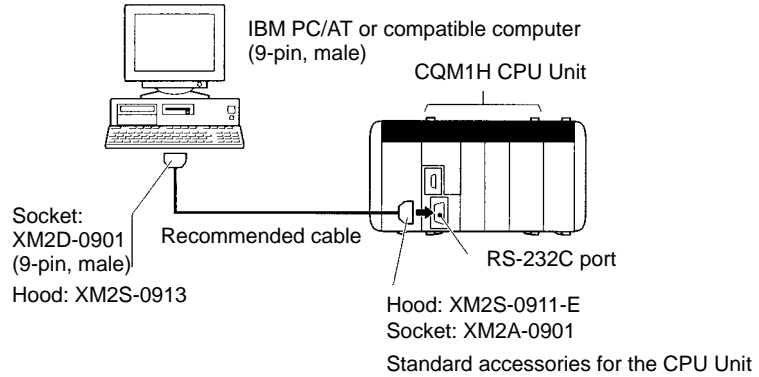

Recommended Cables

UL2464 AWG28 × 5P IFS-RVV-SB (UL standard) (Fujikura Ltd.)

AWG28 × 5P IFVV-SB (not UL standard) (Fujikura Ltd.)

UL2464-SB (MA) 5P × 28AWG (7/0.127) (UL standard) (Hitachi Cable Ltd.)

CO-MA-VV-SB 5P × 28AWG (7/0.127) (not UL standard) (Hitachi Cable Ltd.)

3-1-9 Inner Board Slots 1 and 2

CQM1H-CPU51 or CQM1H-CPU61 CPU Unit has two slots for mounting Inner Boards: Slot 1 (left slot) and slot 2 (right slot).

Note The Inner Boards that can be mounted are different for each slot. For details refer to 3-4 *Inner Boards*.

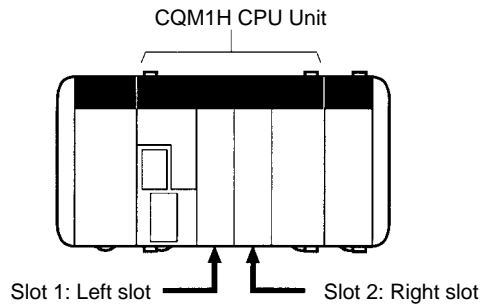

3-1-10 Built-in Inputs

The CPU Unit has 16 built-in inputs. The 16 input bits in IR 000 are always allocated to these inputs. For specifications, refer to 2-2-1 CPU Unit's Built-in 24-V DC Inputs.

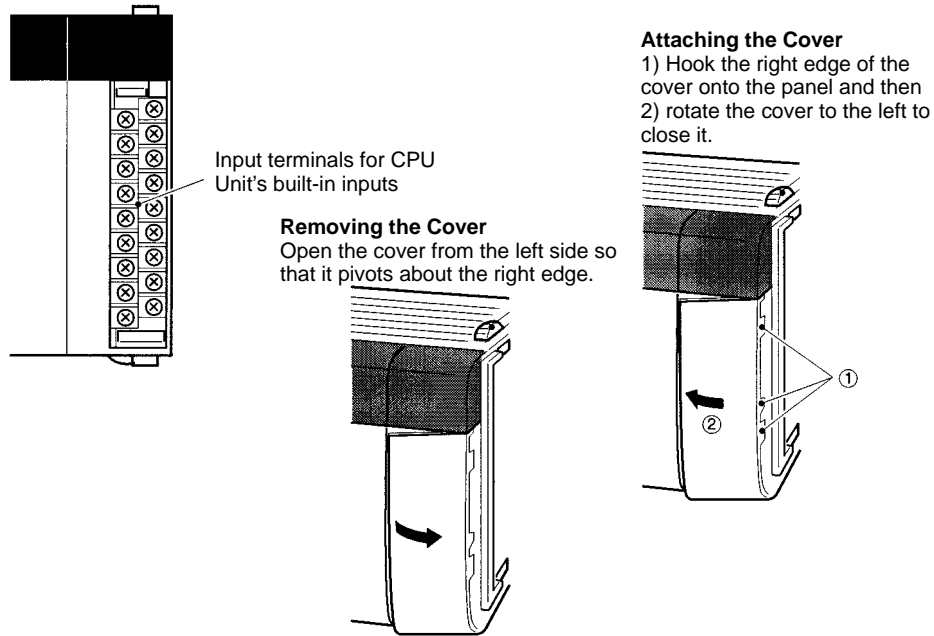

3-2 Power Supply Unit

There are three AC Power Supply Units available, the CQM1-PA203, the CQM1-PA206, and the CQM1-PA216, There is also one DC Power Supply Unit available, the CQM1-PD026. Select a Power Supply Unit that matches the current requirements of the system.

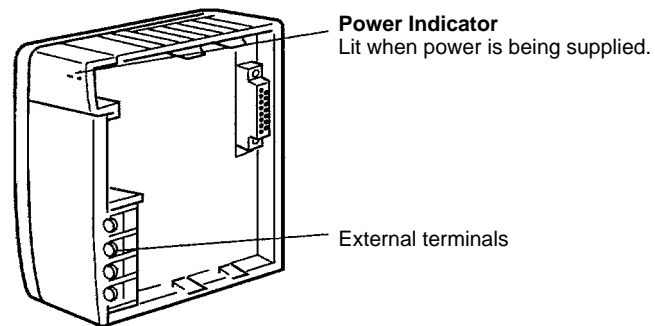

3-2-1 Power Supply Unit Components

The following diagram shows the basic components of a Power Supply Unit.



Crimp Terminals

Use the crimp terminals shown below for Power Supply Unit wiring. The connectors should be less than 7 mm wide and the wires should be between 1.04 and 2.63 mm².

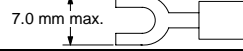
Power supply	Model number	Crimp terminal
AC power	CQM1-PA203 CQM1-PA206 CQM1-PA216	7.0 mm max. 
DC power	CQM1-PD026	7.0 mm max.  7.0 mm max. 

3-2-2 Selecting a Power Supply Unit

As mentioned previously, there are three AC Power Supply Units and one DC Power Supply Unit. Select the appropriate Power Supply Unit based on the total 5-V DC current requirements of the Units in the configured system and the 24-V DC output terminals (PA206/PA216).

Calculation Example:

To calculate the capacity required for a PC configuration consisting of the CPU Unit (e.g., CPU21), two 16-point DC Input Units, and three 16-point Contact Output Units, perform the following calculation:

$$\text{CPU Unit (CPU21) current capacity} + \text{16-point Input Unit current capacity} \times 2 + \text{16-point Contact Output Unit current capacity} \times 3 = 0.82 + 0.085 \times 2 + 0.85 \times 3 = 3.54$$

A Power Supply Unit with a capacity of at least 3.54 A is required.

Model number	Capacity
CQM1-PA203	5 V DC, 3.6 A (18 W)
CQM1-PA206, CQM1-PA216	5 V DC, 6.0 A; 24 V DC output, 0.5 A (30 W total) The total power consumption from the 5-V DC supply and 24-V DC output must be less than 30 W. In other words: 5 V DC current consumption \times 5 + 24 V DC current consumption \times 24 \leq 30 (W).
CQM1-PD026	5 V DC, 6 A (30 W)

Current Consumptions

The following table shows the current consumption of the CPU Unit and I/O Units:

Unit		Model number	Current consumption (5 V DC)
CPU Units		CQM1H-CPU11	800 mA
		CQM1H-CPU21	820 mA
		CQM1H-CPU51	840 mA
		CQM1H-CPU61	840 mA
Inner Boards	Pulse I/O Board	CQM1H-PLB21	160 mA
	Absolute Encoder Interface Board	CQM1H-ABB21	150 mA
	High-speed Counter Board	CQM1H-CTB21	400 mA
	Analog Setting Board	CQM1H-AVB41	10 mA
	Analog I/O Board	CQM1H-MAB42	400 mA
	Serial Communications Board	CQM1H-SCB41	200 mA
Communications Unit	Controller Link Unit	CQM1H-CLK21	270 mA

Unit	Model number	Current consumption (5 V DC)
DC Input Units	CQM1-ID111	85 mA
	CQM1-ID112	170 mA
	CQM1-ID211	50 mA
	CQM1-ID212	85 mA
	CQM1-ID213	170 mA
	CQM1-ID214	170 mA
AC Input Units	CQM1-IA121/221	50 mA
Contact Output Units	CQM1-OC221	430 mA
	CQM1-OC222	850 mA
	CQM1-OC224	440 mA
Transistor Output Units	CQM1-OD211	90 mA
	CQM1-OD212	170 mA
	CQM1-OD213	240 mA
	CQM1-OD214	170 mA
	CQM1-OD215	110 mA
	CQM1-OD216	240 mA
Triac Output Unit	CQM1-OA221	110 mA
	CQM1-OA222	250 mA
B7A Interface Units	CQM1-B7A□□	100 mA
G730 Interface Units	CQM1-G7M21 (Master)	250 mA
	CQM1-G7N11/01 Expansion Master	80 mA
I/O Link Unit	CQM1-LK501	150 mA
Analog Input Unit	CQM1-AD041	80 mA
Analog Output Unit	CQM1-DA021	90 mA
Power Supply Units	CQM1-IPS01	420 mA
	CQM1-IPS02	950 mA
Sensor Unit	CQM1-SEN01	600 mA max.
Linear Sensor Interface Unit	CQM1-LSE01	380 mA
	CQM1-LSE02	450 mA
Temperature Control Units	CQM1-TC00□	220 mA
	CQM1-TC10□	
	CQM1-TC20□	190 mA
	CQM1-TC30□	
CompoBus Units	CQM1-SRM21	180 mA
	CQM1-DRT21	80 mA
I/O Control Units	CQM1H-IC101	2 mA
I/O Interface Units	CQM1H-II101	3 mA

Unit Limits for Expansion I/O Blocks

The current consumption limits for the CPU Block and Expansion I/O Block are given in the following table. Be sure that current consumption of the connected Units does not exceed the following limits.

Block	Number of Units	Maximum current consumption	
CPU Block	5 max.	3.0 A max. (See note 1.)	5.0 A max. total (See note 4.)
Expansion I/O Block	11 max.	2.0 A max. (See note 2.)	

- Note**
1. The CPU Block current consumption includes the CPU Unit, Communications Unit, Inner Boards, and I/O Control Unit.
 2. The Expansion I/O Block current consumption includes I/O Interface Unit.

3. An Analog Power Supply Unit must be counted as a Unit, just like I/O or Dedicated I/O Units.
4. The maximum current consumption will be 3.6 A if the CQM1-PA203 Power Supply Unit is used.

3-2-3 Unit Weights

CPU Units

Model number	Weight
CQM1H-CPU11	500 g max
CQM1H-CPU21	510 g max
CQM1H-CPU51	
CQM1H-CPU61	

Power Supply Units

Model number	Weight
CQM1-PA203	460 g max
CQM1-PA206	560 g max
CQM1-PA216	
CQM1-PD026	

Inner Boards

Inner Board	Model number	Weight
Pulse I/O Board	CQM1H-PLB21	90 g max
Absolute Encoder Interface Board	CQM1H-ABB21	
High-speed Counter Board	CQM1H-CTB21	
Analog Setting Board	CQM1H-AVB41	60 g max
Analog I/O Board	CQM1H-MAB42	100 g max
Serial Communications Board	CQM1H-SCB41	90 g max

Communications Unit

Unit	Model number	Weight
Controller Link Unit	CQM1H-CLK21	170 g max

I/O Units

Unit	Model number	Weight
DC Input Units	CQM1-ID111	180 g max
	CQM1-ID112	160 g max
	CQM1-ID211	180 g max
	CQM1-ID212	
	CQM1-ID213	160 g max
AC Input Units	CQM1-IA121	210 g max
	CQM1-IA221	
Contact Output Units	CQM1-OC221	200 g max
	CQM1-OC222	230 g max
	CQM1-OC224	270 g max
Transistor Output Units	CQM1-OD211	200 g max
	CQM1-OD212	180 g max
	CQM1-OD213	160 g max
	CQM1-OD214	210 g max
	CQM1-OD215	240 g max
AC Output Units	CQM1-OA221	
	CQM1-OA222	
I/O Control Unit	CQM1H-IC101	131 g max.
I/O Interface Unit	CQM1H-II101	211 g max. (including the end cover)

Note For details on Dedicated I/O Units, refer to the *CQM1 Dedicated I/O Units Operation Manual (W238)*.

3-3 I/O Units

There are two basic types of I/O Unit: Those with terminal blocks and those with connectors.

The following diagram shows the basic components of I/O Units.

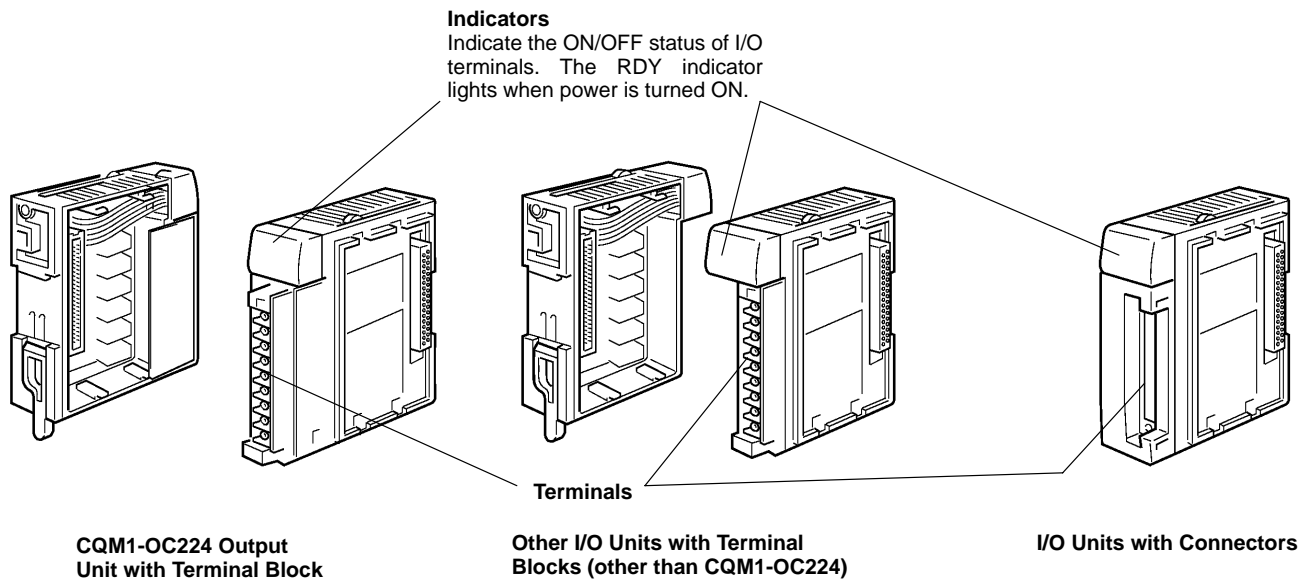

3-4 Inner Boards

The Inner Boards listed in the following table are available. These must be mounted in Inner Board slot 1 or slot 2 of a CQM1H-CPU51 or CQM1H-CPU61 CPU Unit. The slots that can be used are determined by the shape of the Board.

Name	Model number	Specifications	Mountable slot	
			Slot 1 (left slot)	Slot 2 (right slot)
High-speed Counter Board	CQM1H-CTB41	Four pulse inputs and four external outputs	YES	YES
Pulse I/O Board	CQM1H-PLB21	Two pulse inputs and two pulse outputs	No	YES
Absolute Encoder Interface Board	CQM1H-ABB21	Two absolute encoder inputs		
Analog Setting Board	CQM1H-AVB41	Four analog settings	YES (See note.)	YES (See note.)
Analog I/O Board	CQM1H-MAB42	Four analog inputs and two analog outputs	No	YES
Serial Communications Board	CQM1H-SCB41	One RS-232C port and one RS-422A/485 port	YES	No

Note The Analog Setting Board cannot be mounted in both slots at the same time.

CQM1H-CTB41
High-speed Counter Board

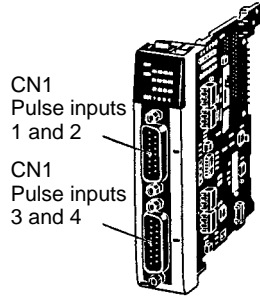

CQM1H-PLB21
Pulse I/O Board

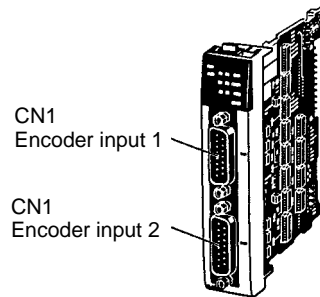

CQM1H-ABB21
Absolute Encoder Interface Board

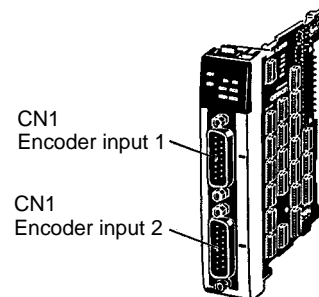

CQM1H-AVB41
Analog Setting Board

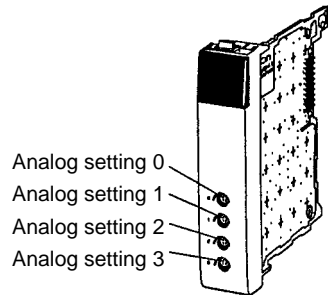

CQM1H-MAB42
Analog I/O Board

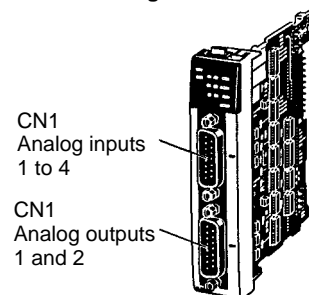

CQM1H-SCB41
Serial Communications Board

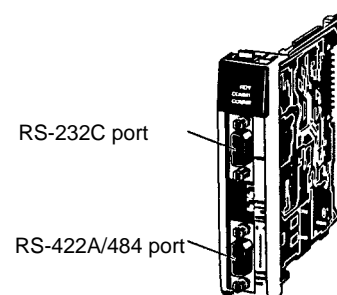

CQM1H-CPU51/CPU61
CPU Unit

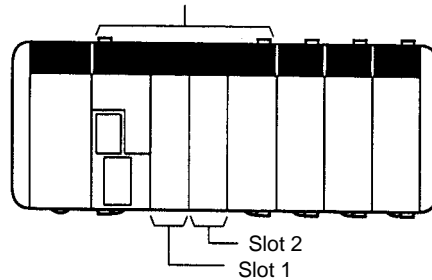

3-5 Products for Expansion I/O Blocks

An Expansion I/O Block can be connected to enable connecting more than 11 Units or two mounted the PC in two tiers in a narrow location. Expansion I/O Blocks are supported by all CQM1H CPU Units.

Name	Model	Specifications	
I/O Control Unit	CQM1H-IC101	Connects to right end of CPU Block.	
I/O Interface Unit	CQM1H-II101	Connected to left end of Expansion I/O Block. An End Cover is included.	
Expansion I/O Cables	CS1W-CN313	Length: 0.3 m	Connects the I/O Control Unit to the I/O Interface Unit.
	CS1W-CN713	Length: 0.7 m	

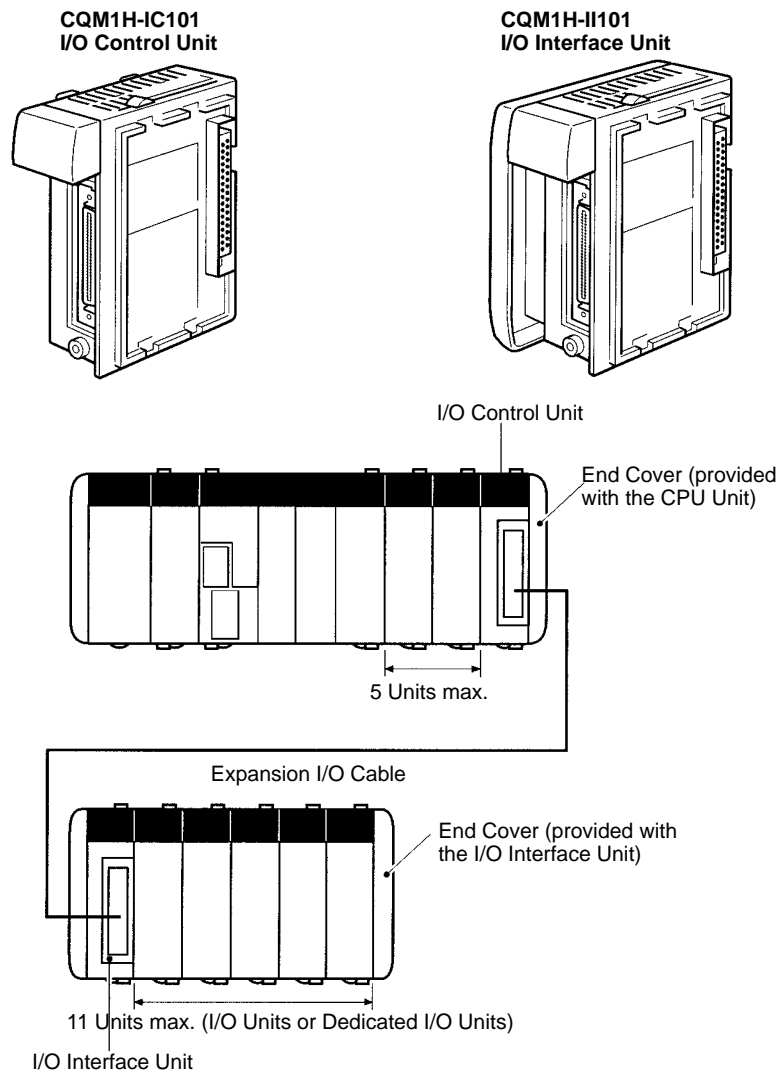

- Note**
1. Connect the I/O Control Unit to the right end of the CPU Block.
 2. Connect the End Cover provided with the CPU Unit to the I/O Control Unit.
 3. An End Cover is provided with the I/O Interface Unit. Connect this End Cover to the right end of the Expansion I/O Block.
 4. Use either the CS1W-CN331 (0.3 m) or the CS1W-CN731 (0.7 m) Expansion I/O Cable. Do not use a cable that is longer than 0.7 m.

3-6 Programming Devices

There are two types of Programming Devices that can be used: Hand-held Programming Consoles and Support Software that is run on a Windows computer. Support Software is usually used to write the programs, and a Programming Console is then used to change operating modes, edit programs, and monitor a limited number of points.

The following Programming Devices can be used with the CQM1H.

- Programming Consoles
- Support Software
 - CX-Programmer V1.2 or higher (see note 1)
 - SYSMAC-CPT (see note 2)
 - SYSMAC Support Software (SSS) (see note 2)

- Note**
1. None of the CQM1H-series CPU Units can connect to CX-Programmer V1.1 or lower.
 2. Refer to *Restrictions when Using Support Software* under 3-6-2 *Support Software* when using the SYSMAC-CPT or SYSMAC Support Software.

3-6-1 Programming Consoles

There are two Programming Consoles that can be used with the CQM1H: The CQM1H-PRO01-E, CQM1-PRO01-E and C200H-PRO27-E. These Programming Consoles are shown below.

CQM1H-PRO01-E Programming Console

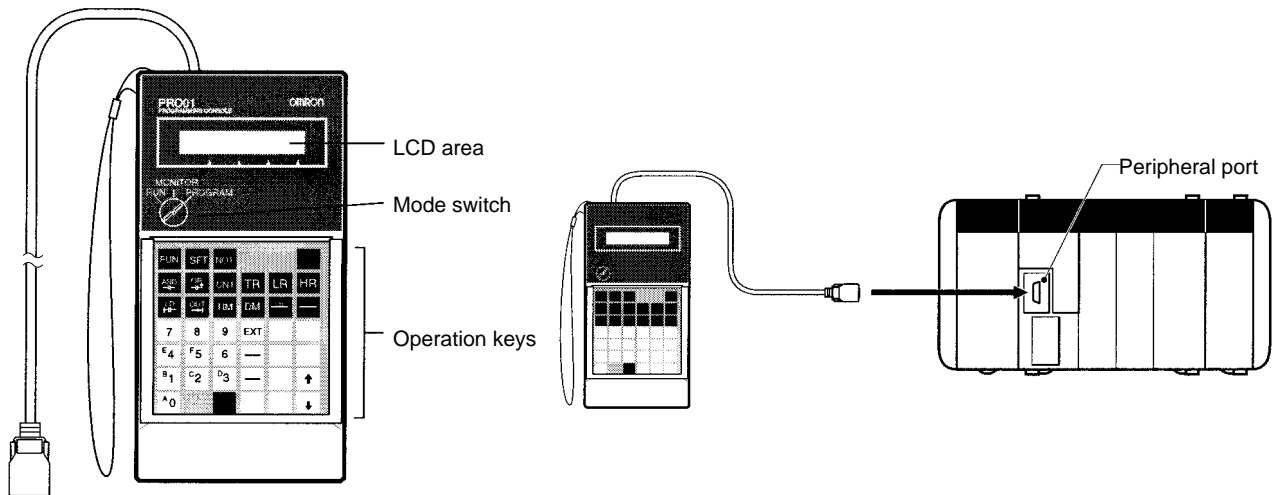

CQM1-PRO01-E Programming Console

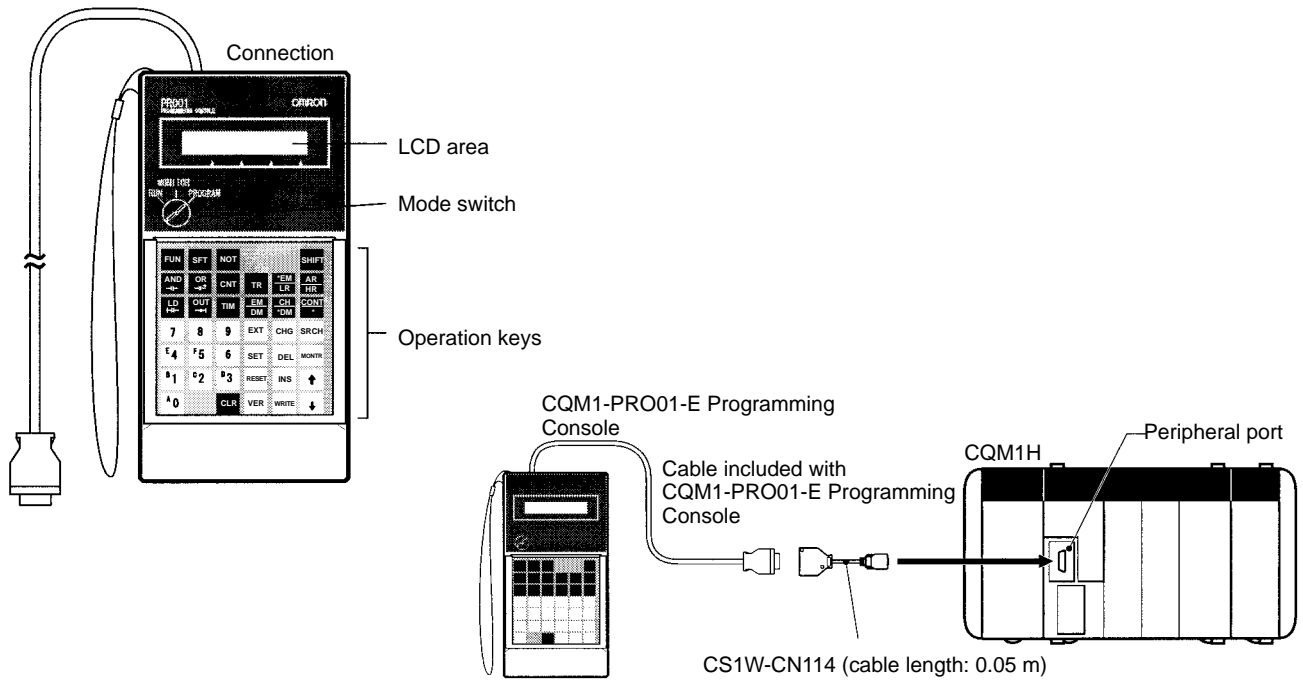

C200H-PRO27-E Programming Console

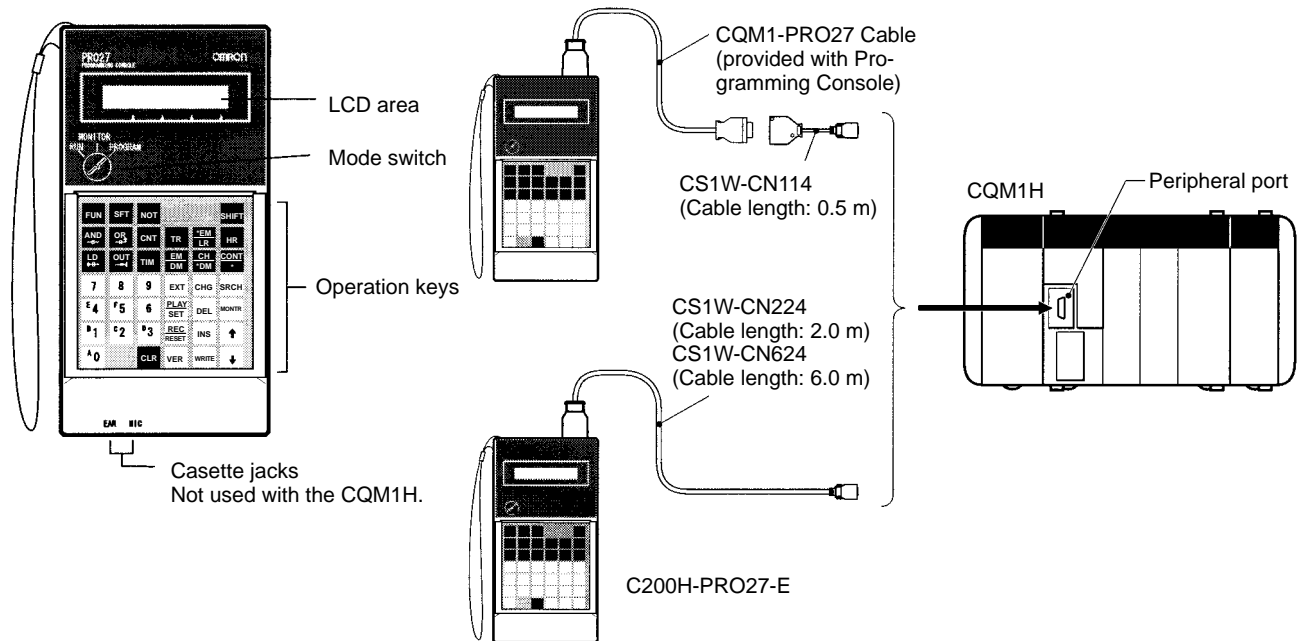

Programming Console Connections

Unit	Port	DIP switch	Programming Console	Cable	
				Length	Model number
CPU Unit	Built-in peripheral port	Turn OFF pin 7.	CQM1H-PRO01-E	2 m	Cable included with Programming Console
			CQM1-PRO01-E	2 m and 0.05 m	Cable included with Programming Console and CS1W-CN114
			C200H-PRO27-E	2 m and 0.05 m	C200H-CN222 and CS1W-CN114
				4 m and 0.05 m	C200H-CN422 and CS1W-CN114
				2 m	CS1W-CN224
				6 m	CS1W-CN624

DIP Switch Settings

When connecting a Programming Console to the peripheral port, turn OFF pin 7 on the DIP switch. When pin 7 is OFF, the setting of pin 5 and the PC Setup settings are disabled as shown in the following table.

DIP switch pin 5	DIP switch pin 7	PC Setup (DM 6650)
Disabled	OFF	Disabled

3-6-2 Support Software

The different types of Support Software that can be used with the CQM1H are shown in the following table.

Name	Model number	Format	Computer	OS	Serial communications mode	Model	Functional limitations
CX-Programmer V1.2 or higher	WS02-CXP□□-E	CD-ROM	IBM PC/AT or compatible	Microsoft Windows 95 or 98	Peripheral bus or Host Link	CQM1H	No
SYSMAC-CPT	WS01-CPTB1-E	3.5-inch floppy disks (1.44 MB) and CD-ROM		Microsoft Windows V 3.1	Host Link	CQM1-CPU43	Yes (see note)
SYSMAC Support Software (SSS)	C500-ZL3AT1-E	3.5-inch floppy disks		Microsoft DOS V 3.2 or higher	Peripheral bus or Host Link	CQM1	

Note Functional limitations are shown in the following table.

Restrictions when Using Support Software

Item	CX-Programmer V1.2 or later	SYSMAC-CPT	SYSMAC Support Software (SSS)
PC model	Select CQM1H.	Select CQM1-CPU43-E.	Select CQM1.
CPU Unit models that are not supported	None	The CQM1H-CPU61 CPU Unit cannot be used. (An error message will appear when you attempt to connect.) The CQM1H-CPU11/21/51 CPU Units can be used.	The CQM1H-CPU61 CPU Unit cannot be used. (An error message will appear when you attempt to connect.) The CQM1H-CPU11/21/51 CPU Units can be used.
Instructions that cannot be used	None	The following instructions are not supported by the CQM1 CPU Units and cannot be used on the SYSMAC-CPT. If an attempt is made to transfer a program containing any of them to the SYSMAC-CPT, an error will occur. Timer Instructions TTIM Serial Communications Instructions PMCR and STUP Network Communications Instructions SEND, RECV, and CMND Floating-point Instructions FIX, FIXL, FLT, FLTL, +F, -F, *F, /F, DEG, RAD, SIN, COS, TAN, ASIN, ACOS, ATAN, SQRT, EXP, and LOG	The following instructions can be used on the SSS by transferring them to the SSS from the CQM1H-series CPU Unit as expansion instructions. Use the transfer operation for expansion instructions under the expansion functions menu. Network Communications Instructions CMND Floating-point Instructions FIX, FIXL, FLT, FLTL, +F, -F, *F, /F, DEG, RAD, SIN, COS, TAN, ASIN, ACOS, ATAN, SQRT, EXP, and LOG Other instructions that are new on the CQM1H (in respect to the CQM1) can be used without transferring them as expansion instructions.
Memory displays	Displayed for CQM1H.	Memory will be displayed for the CQM1-CPU43, i.e., to a maximum of 7.2 Kwords.	Memory will be displayed for the CQM1 CPU Units, i.e., to a maximum of 7.2 Kwords.
DM verification	None	With the CQM1H-CPU11/21, the error message "Verification Error" will be displayed if a verification check results in a value other than "0000" for any data in DM 3072 to DM 6143 of the CPU Unit.	Cannot be used. (A communications error will be generated the PC will be offline.)

Serial Communications Mode Characteristics

The two following serial communications modes are supported for connecting Support Software to the PC.

Serial Communications Mode	Features
Peripheral bus	High-speed communications are possible. Usually, this mode should be used when connecting with CX-Programmer. Only 1:1 connection is supported.
Host Link (SYSMAC WAY)	Basic protocol for communications with a host computer. Communications speed lower than peripheral bus. One-to-one or one-to-many communications are possible. Connections to a modem or Optical Link Adapter are possible.

DIP Switch and PC Setup Settings

Peripheral Bus Connection

Make the following settings when connecting Support Software to the peripheral

port via the peripheral bus protocol. The serial communications mode must be set to Host Link.

DIP switch pin 5	DIP switch pin 7	PC Setup: DM 6650
OFF	ON	0000 Hex (standard settings) or 0001 Hex (custom settings)
ON	ON	Ignored (standard settings)

Note Always turn ON pin 7 on the DIP switch when connecting Support Software running on a computer using the peripheral bus. You will not be able to connect if pin 7 is OFF.

Host Link Connection

Make the following settings when connecting Support Software via the Host Link protocol.

Peripheral Port

Use the following settings for the standard communications settings in the PC Setup:

DIP switch pin 5	DIP switch pin 7	PC Setup: DM 6650
OFF	ON	0000 Hex (standard settings)

Use the following settings to make custom communications settings in the PC Setup:

DIP switch pin 5	DIP switch pin 7	PC Setup: DM 6650
OFF	ON	0001 Hex (Custom settings: Set the baud rate, data length, etc., in DM 6651)

Use the following settings for communications according to pin 5 default settings:

DIP switch pin 5	DIP switch pin 7	PC Setup: DM 6650
ON	ON	Ignored (standard settings)

Note Always turn ON pin 7 on the DIP switch when connecting Support Software running on a computer using a Host Link connection. You will not be able to connect if pin 7 is OFF.

RS-232C Port

Use the following settings for the standard communications settings in the PC Setup:

DIP switch pin 5	DIP switch pin 7	PC Setup: DM 6645
OFF	Ignored	0000 Hex (Standard settings)

Use the following settings to make custom communications settings in the PC Setup:

DIP switch pin 5	DIP switch pin 7	PC Setup: DM 6645
OFF	Ignored	0001 Hex (Custom settings: Set the baud rate, data length, etc., in DM 6646)

Use the following settings for communications according to pin 5 default settings:

DIP switch pin 5	DIP switch pin 7	PC Setup: DM 6645
ON	Ignored	Ignored (standard settings)

Connecting Cables

Connecting to Peripheral Port

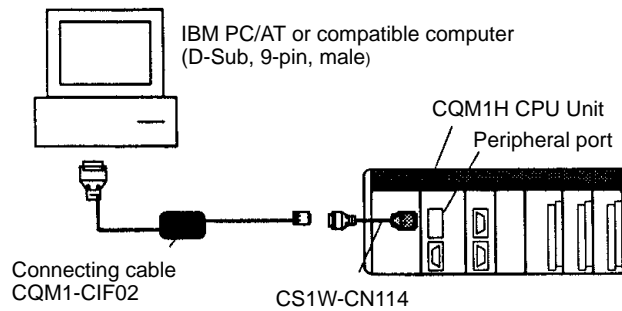

- Note**
1. Connecting cables CS1W-CN225/625/227/627 cannot be used with the CQM1H.
 2. The FIT 10/20 connecting cable CQM1-CIF-11 cannot be used with the CQM1H.

Connecting to RS-232C Port (on CPU Unit or Serial Communications Board)

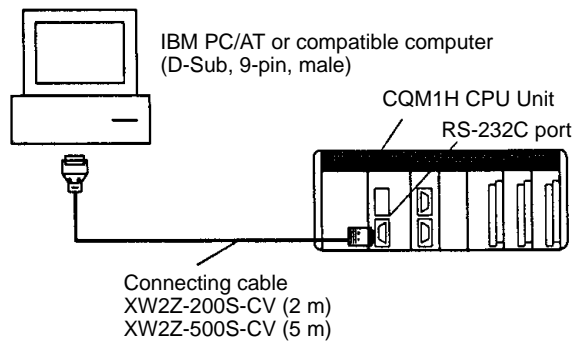

One-to-one Communications

Use the following cables for one-to-one communications between the personal computer and the PC.

Unit/Board	Port	Serial communications mode	Model number	Length	Comments	Startup Mode (see note)
CPU Unit	Peripheral port	Peripheral bus or Host Link (SYS-MAC WAY)	CS1W-CN114 + CQM1-CIF02	0.05 m + 3.3 m	---	PROGRAM mode
	RS-232C port (D-Sub, 9-pin, male)	Host Link (SYSMAC WAY)	XW2Z-200S-CV	2 m	Use a connector for which ESD countermeasures have been taken.	Ignored
XW2Z-500S-CV			5 m			
Serial Communications Board	RS-232C port (D-Sub, 9-pin, female)	Host Link (SYSMAC WAY)	XW2Z-200S-CV	2 m	Use a connector for which ESD countermeasures have been taken.	
			XW2Z-500S-CV	5 m		

Note The Startup Modes in the above table are for when DM 6600 in the PC Setup is set to the default settings. The Startup Mode depends on the type of cable used. For details refer to 5-2-3 Startup Mode.

Direct Connection to Peripheral Port

It is possible to connect the personal computer directly to the peripheral port using the CS1W-CN226/626 Connecting Cable (dedicated cable for IBM PC/AT or compatible computers). If this cable is used, the Startup Mode (when DM 6600 in the PC Setup is set to the default settings), will be RUN mode as shown in the following table.

Unit	Port	Serial communications mode	Model number	Length	Startup Mode (see note)
CPU Unit	Peripheral port	Peripheral bus or Host Link (SYSMAC WAY)	CS1W-CN226 or CS1W-CN626	2 m or 6 m	RUN mode

Note The Startup Mode in the above table is for when DM 6600 in the PC Setup is set to the default settings. The Startup Mode depends on the type of cable used. For details refer to 5-2-3 Startup Mode.

Connecting to Peripheral Port using RS-232C Cable

When connecting an RS-232C cable to the peripheral port, use the CS1W-CN118 Connecting Cable as indicated below. When the XW2Z-200S-CV/500S-CV is connected, the Startup Mode (when DM 6600 in the PC Setup is set to the default settings) will be RUN mode.

Unit	Port	Serial communications mode	Model number	Length	Comments	Startup Mode (see note)
CPU Unit	Peripheral port	Peripheral bus or Host Link (SYSMAC WAY)	CS1W-CN118 + XW2Z-200S-CV/500S-CV	0.1 m + (2 m or 5 m)	Use a connector for which ESD countermeasures have been taken with the XW2Z-□□□S-CV.	RUN mode
			CS1W-CN118 + XW2Z-200S-V/500S-V		---	PROGRAM mode

Note The Startup Modes in the above table are for when DM 6600 in the PC Setup is set to the default settings. The Startup Mode depends on the type of connecting cable used. For details refer to 5-2-3 Startup Mode.

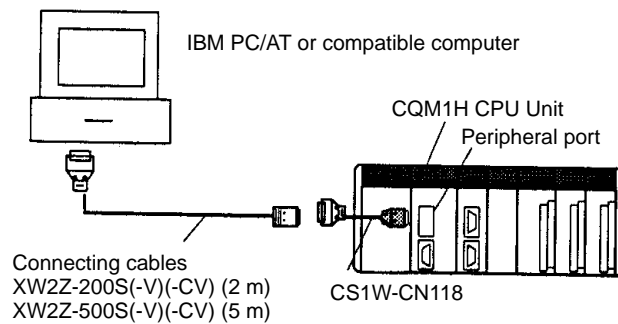

Connecting to RS-232C Port using RS-232C Cable

When connecting an IBM PC/AT or compatible computer to the RS-232C port (built-in or on the Serial Communications Board) using an RS-232C cable, the following connection methods are possible.

Unit/Board	Port	Serial communications mode	Model number	Length	Comments	Startup Mode (see note)
CPU Unit	Built-in RS-232C port (D-Sub, 9-pin, female)	Host Link (SYSMAC WAY)	XW2Z-200S-V	2 m	---	Ignored
			XW2Z-500S-V	5 m		
Serial Communications Board	RS-232C port (D-Sub, 9-pin, female)		XW2Z-200S-V	2 m		
			XW2Z-500S-V	5 m		

Note The Startup Mode in the above table is for when DM 6600 in the PC Setup is set to the default setting. The Startup Mode depends on the type of connecting cable used. For details refer to 5-2-3 Startup Mode.

One-to-many Communications

The following table shows the connections methods for communications between one personal computer and many PCs.

Serial communications mode	RS-232C cable at the personal computer	RS-232C-to-RS422A/485 Converting Link Adapter	RS-422A/485-to-RS-232C Converting Link Adapter	Connecting cable		Port at PC
				Length	Model number	
Host Link	Make your own cable (See below.)	3G2A9-AL004-E	NT-AL001-E	0.7 m	XW2Z-070T-1	RS-232C port (D-Sub, 9-pin, female)
				2 m	XW2Z-200T-1	

Prepare the RS-232C cable between the 3G2A9-AL004-E Link Adapter and the computer as shown below.

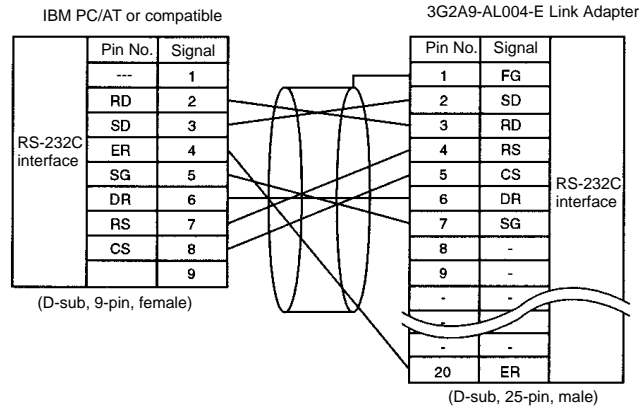

The DIP switch settings of the NT-AL001-E Link Adapter are shown below.

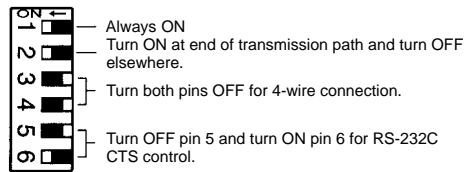

Preparing RS-232C Cables

Connecting to CX-Programmer

When connecting the RS-232C port to the CX-Programmer, set the communications mode to Host Link mode and connect in the following way.

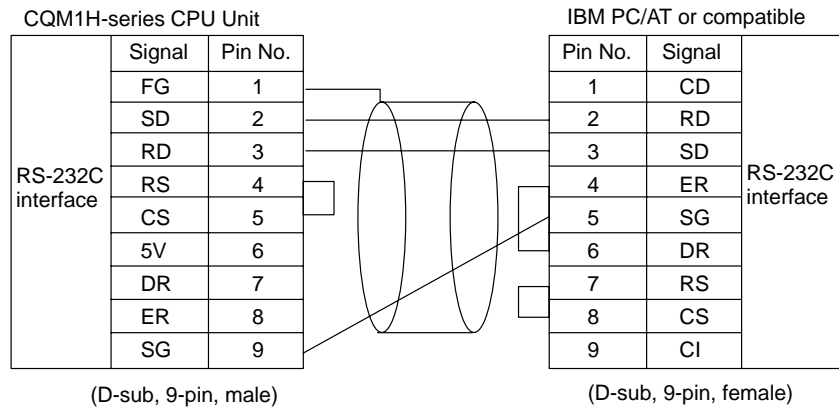

When preparing an RS-232C cable to be connected to the RS-232C port, use the following connector cables.

Applicable Connectors

CPU Unit Connector

Item	Model number	Specifications	
Socket	XM2A-0901	9-pin male	Used together (One of each provided with CPU Unit.)
Hood	XM2S-0911-E	9-pin, millimeter screws	

Personal Computer Connector

Item	Model number	Specifications	
Socket	XM2D-0901	9-pin female	Used together
Hood	XM2S-0913	9-pin, inch screws	

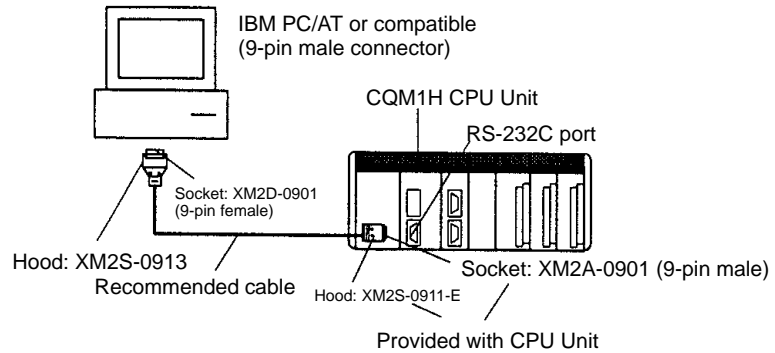

Recommended Cables

- Fujikura Ltd.: UL2464 AWG28 × 5P IFS-RVV-SB (UL product)
AWG 28 × 5P IFVV-SB (non-UL product)
- Hitachi Cable, Ltd.: UL2464-SB(MA) 5P × 28AWG (7/0.127) (UL product)
CO-MA-VV-SB 5P × 28AWG (7/0.127) (non-UL product)

SECTION 4

Installation

This section describes how to install the CQM1H PC, including how to mount Units, wire I/O, and connect Programming Devices. Installation precautions and mounting dimensions are also provided. Follow the instructions carefully to ensure proper operation. Improper installation can cause the PC to malfunction.

4-1	Fail-safe Circuits
4-2	Installation Precautions
4-3	Mounting Dimensions
4-4	Connecting PC Components
4-5	Inner Board Installation
4-6	DIN Track Installation
4-7	Wiring and Connections
4-7-1	Power Supply Unit Wiring
4-7-2	Connecting the CPU Block and Expansion I/O Block
4-7-3	I/O Unit Wiring
4-7-4	Preparing Cables for 32-point Input and Output Units
4-8	I/O Unit Wiring Precautions
4-9	Connecting Programming Devices
4-10	Connecting Programmable Terminals

4-1 Fail-safe Circuits

You must set up safety circuits outside of the PC to prevent dangerous conditions in the event of errors in the PC or external power supply.

 **WARNING** Take any safety measures necessary outside of the PC to ensure the safety of the system in the event of an error due to PC malfunction or external factors. Observe the following precautions. Failure to do so could lead to serious or possibly fatal injury.

- Provide interlock circuits, limit circuits, emergency stop circuits, and similar safety measures in external circuits (i.e., not only in the Programmable Controller).
- Operation will stop and all outputs will turn OFF when the PC detects an error or when a FALS(07) (fatal error) instruction is executed. You must take any safety measures necessary outside of the PC to ensure the safety of the system in the event that all outputs turn OFF.
- It is possible for an output to remain ON or OFF due to a malfunction in the internal circuits of an Output Unit, such as a relay or transistor malfunction. Provide any circuits necessary outside of the PC to ensure the safety of the system in the event that an output fails to turn OFF or ON.
- If there is an overload or a short-circuit in the PC's 24-V DC service power supply, the voltage may drop and the outputs may turn OFF. Take any safety measures necessary outside of the PC to ensure the safety of the system in the event that outputs turn OFF.

Supply Power to the PC before Outputs

If the PC's power supply is turned ON after the controlled system's power supply, outputs in Units such as DC Output Units may malfunction momentarily. To prevent any malfunction, add an external circuit that prevents the power supply to the controlled system from going ON before the power supply to the PC itself.

Managing PC Errors

When any of the following errors occurs, PC operation will stop and all outputs from Output Units will be turned OFF.

- Operation of the Power Supply Unit's overcurrent protection circuit
- A CPU error (watchdog timer error)
- A fatal error* (memory error, no END(01) instruction error, I/O bus error, too many I/O points error, or FALS fatal system error)

Be sure to add any circuits necessary outside of the PC to ensure the safety of the system in the event of an error that stops PC operation.

Note *When a fatal error occurs, all outputs from Output Units will be turned OFF even if the IOM Hold Bit has been turned ON to protect the contents of I/O memory. (When the IOM Hold Bit is ON, the outputs will retain their previous status after the PC has been switched from RUN/MONITOR mode to PROGRAM mode.)

Managing Output Malfunctions

It is possible for an output to remain ON due to a malfunction in the internal circuitry of the Output Unit, such as a relay or transistor malfunction. Be sure to add any circuits necessary outside of the PC to ensure the safety of the system in the event that an output fails to go OFF.

Emergency Stop Circuit

The following example emergency stop circuit controls the power supply to the controlled system so that power is supplied to the controlled system only when the PC is operating. Program the Always ON Flag (SR 25313) as the execution condition for an output point from an Output Unit and use this point as a RUN

output. Connect an external relay (CR1) to this RUN output as shown in the following diagram.

Note Use the Always ON Flag (SR 25213) as an execution condition for an Output from the Output Unit.

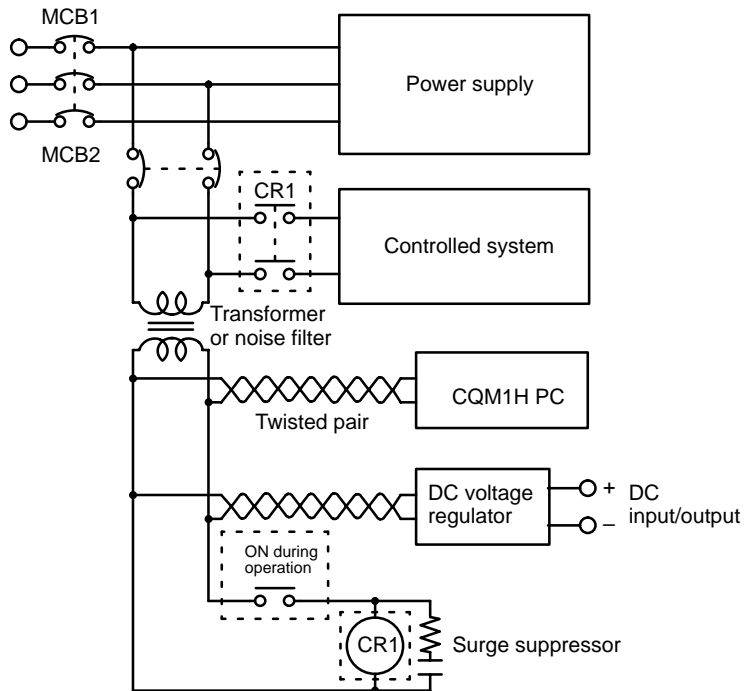

Interlock Circuits

When the PC controls an operation such as the clockwise and counterclockwise operation of a motor, provide an external interlock such as the one shown below to prevent both the forward and reverse outputs from turning ON at the same time.

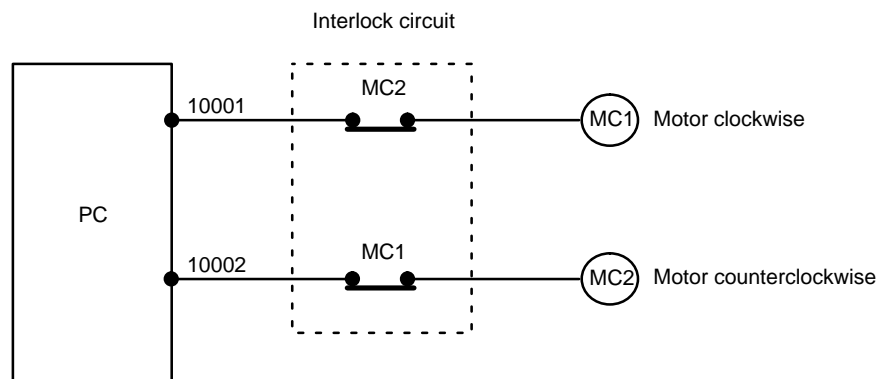

This circuit prevents outputs MC1 and MC2 from both being ON at the same time even if IR 10001 and IR 10002 are both ON, so the motor is protected even if the PC is programmed improperly or malfunctions.

4-2 Installation Precautions

When installing the CQM1H in a control panel, observe the following points.

Ambient Temperature

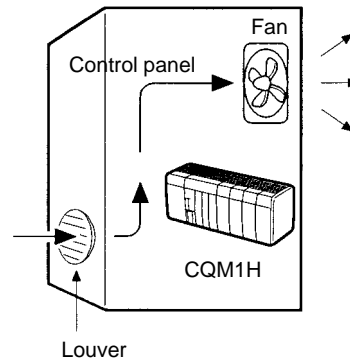

The ambient temperature range in which the CQM1H can be used is 0 to 55°C (0 to 45°C if a Programming Console is connected to the CPU Unit).

Use the CQM1H in a well-ventilated area.

Do not mount the CQM1H directly above heaters, transformers, large-capacity resistors, or any other devices that radiate a large amount of heat energy.

If the ambient temperature is higher than 55°C, install a fan or cooler as shown in the above diagram so that the temperature is maintained at a maximum of 55°C.

Do not install the CQM1H close to high-voltage or power devices.

Maintenance

External Wiring

Observe the following precautions for external wiring.

- When multi-conductor signal cable is being used, avoid combining I/O wires and other control wires in the same cable.
- If wiring racks are parallel, allow at least 300 mm (12 inches) between the racks.
- Run CQM1H power supply lines and power cables (400-V/10-A max. or 220-V/20-A max.) as shown in the following diagram.

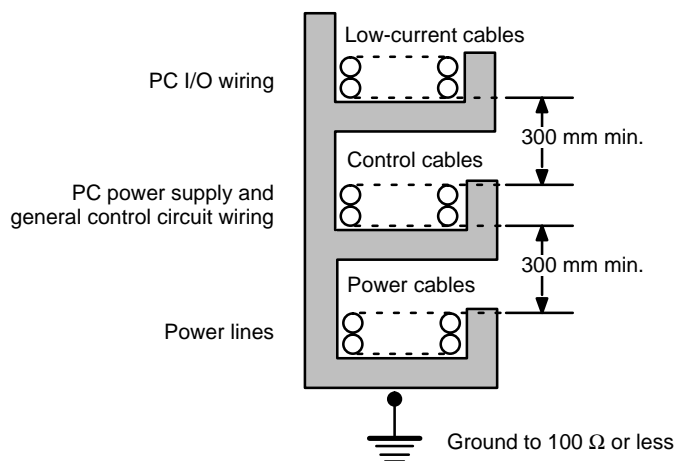

If the I/O wiring and power cables must be placed in the same duct, they must be shielded from each other using grounded steel sheet metal.

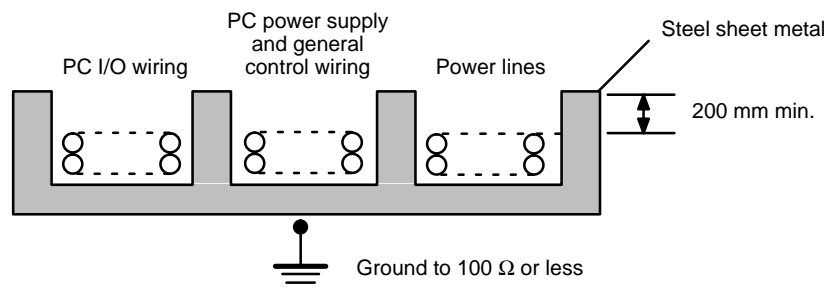

Improving Noise Resistance

Reduce the effects of noise by observing the following points.

- Do not mount the PC in a control panel containing high-voltage equipment.
- Install the PC at least 200 mm (6.5 feet) from power lines.

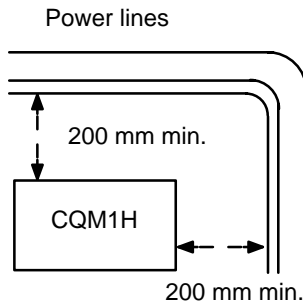

- Ground the mounting plate between the PC and the mounting surface.

PC Orientation

When installing the CQM1H in the control panel, always mount the Units so that the ventilation openings are facing up. Also, there must be at least a 20-mm space both above and below the PC.

Correct

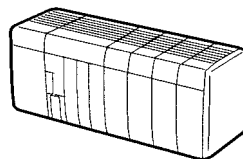

Wrong

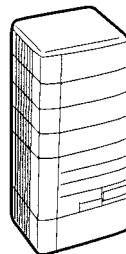

Wrong

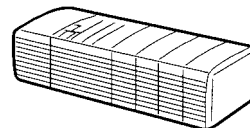

4-3 Mounting Dimensions

The following diagram shows a CQM1H PC consisting of a Power Supply Unit, Communications Unit, CPU Unit, and I/O Units. Be sure to connect an End Cover to the right side of the Unit on the opposite end of the PC from the CPU Unit.

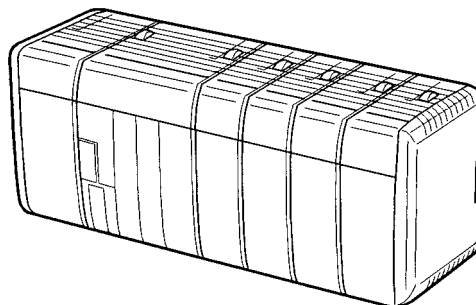

External Dimensions for CPU Block

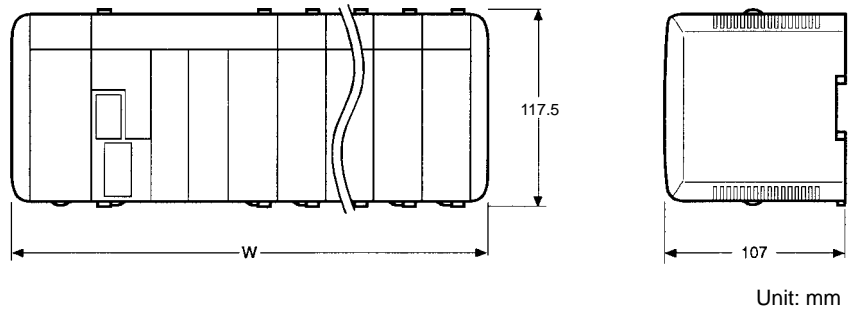

The following table lists the total width, W, of the PC.
 $n = \text{No. of I/O Units} + \text{No. of Dedicated I/O Units}.$

Power Supply Unit	Width (mm)	
	CPU Block only $0 \leq n \leq 11$	With Expansion I/O Block connected $0 \leq n \leq 5$
CQM1-PA203	$32 \times n + 187$	$32 \times n + 219$
CQM1-PA206	$32 \times n + 219$	$32 \times n + 251$
CQM1-PA216		
CQM1-PD026		

Note For example, if a CQM1-CPU51/61 Power Supply Unit is used and there is a total of four I/O Units and Dedicated I/O Units, the width would be 347 mm.
 $W = 32 \times 4 + 219 = 347 \text{ mm}$

If a Communications Unit is connected to the CQM1-CPU51/61, add 32 mm to obtain the total width.

External Dimensions for Expansion I/O Block

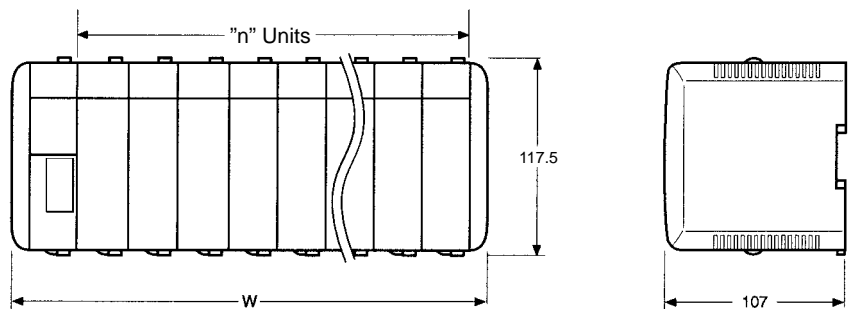

$n = \text{No. of I/O Units} + \text{No. of Dedicated I/O Units}.$
 $W = 32 \times n + 60.2 \text{ (} 1 \leq n \leq 11 \text{)}$

CPU Unit

The following diagrams show the dimensions of the CPU Unit and End Cover, which covers the Unit at the far right side of the PC. The End Cover is provided with the CPU Unit. All dimensions are in millimeters.

CPU Unit Front View

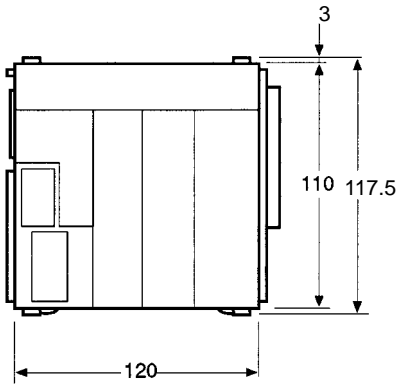

End Cover Front View

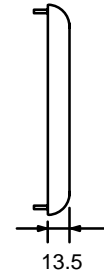

CPU Unit Side View

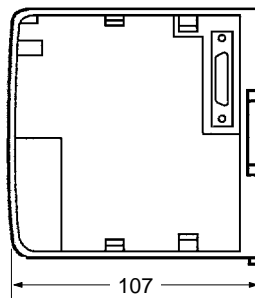

CPU Unit Connected to Programming Device

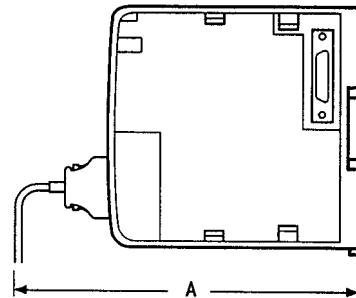

A: Peripheral port: Approx. 160 mm
RS-232C port: Approx. 160 mm

Note The depth is the same for all Units.

CPU Unit with Inner Board Connectors Connected

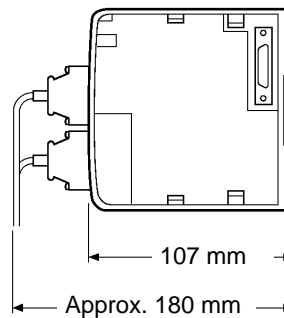

Note The depth is the same for all Units.

Power Supply Units

The following diagrams show the dimensions of the Power Supply Units. All dimensions are in millimeters.

CQM1-PA203

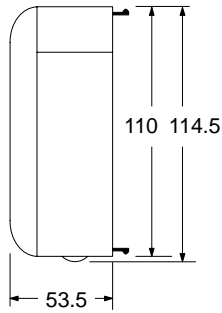

CQM1-PA206/PA216/PD026

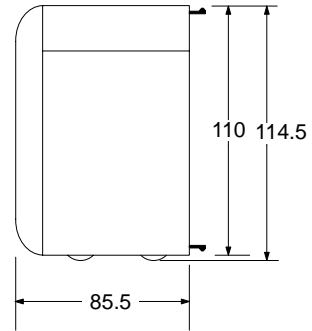

Units for Expansion I/O Blocks

The following diagrams show the dimensions of the I/O Control Unit and I/O Interface Unit. All dimensions are in millimeters.

I/O Control Unit

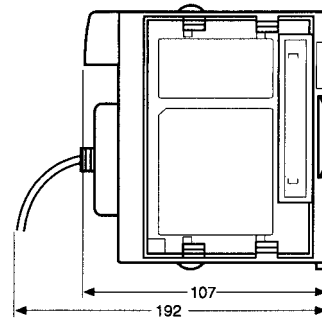
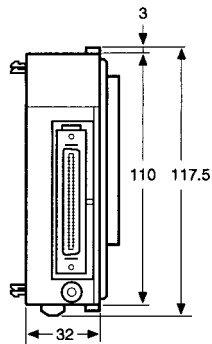

I/O Interface Unit

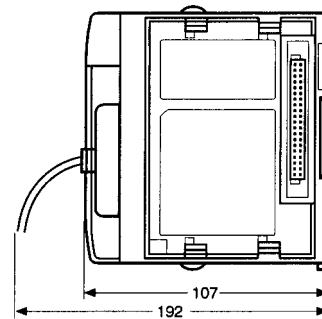
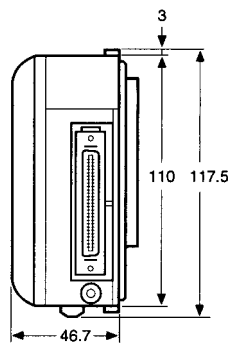

I/O Units

The following diagrams show the dimensions of the I/O Units. All dimensions are in millimeters.

I/O Unit Front View

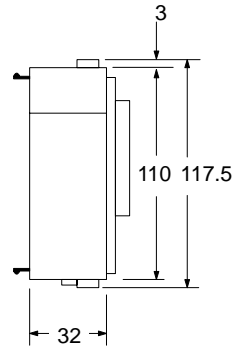

Connector-type I/O Unit Side View

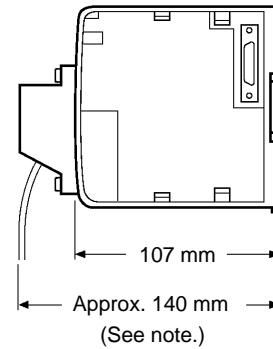

CQM1-OC224 Output Unit Side View

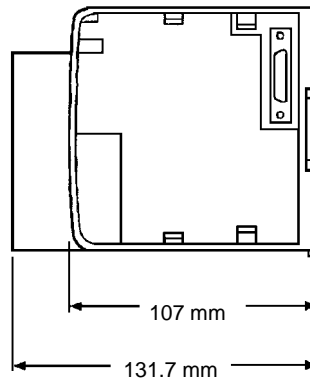

Note The depth of connector-type I/O Units is approx. 120 mm when pressure-welded connectors are used.

Terminal Block

The following diagram shows the dimensions of the terminal block for the terminal block-type I/O Units. All dimensions are in millimeters.

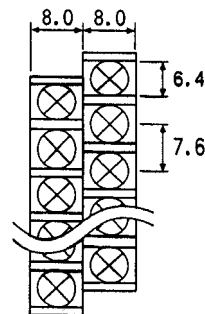

Unit: mm

4-4 Connecting PC Components

The Units that make up a CQM1H PC can be connected simply by pressing the Units together and sliding the locking tabs towards the back of the Units. The End Cover is connected in the same way to the Unit on the far right side of the PC. Follow the procedure listed below to connect PC components.

Always turn OFF the CQM1H when connecting or disconnecting Units. Replace Units only after shutting down the CQM1H system.

- 1, 2, 3... 1. The following diagram shows the connection of two Units that make up a CQM1H PC. Join the Units so that the connectors fit exactly.

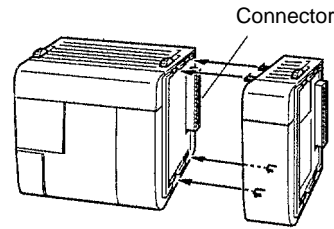

2. The yellow locking tabs at the top and bottom of each Unit lock the Units together. Slide these locking tabs towards the back of the Units as shown below until they click into place.

Note If the locking tabs are not secured properly, the CQM1H may not function properly. Be sure to slide the locking tabs until they are securely in place.

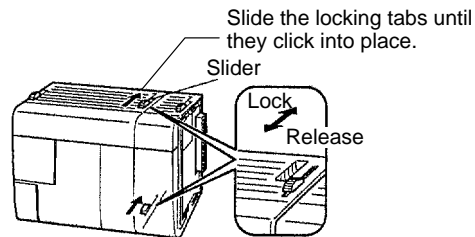

3. Attach the End Cover to the Unit on the far right side of the PC.

CPU Block Only

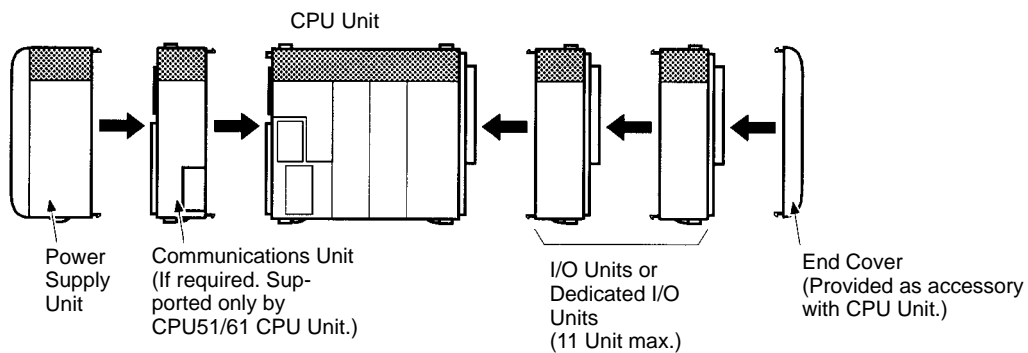

CPU Block for Connection to Expansion I/O Block

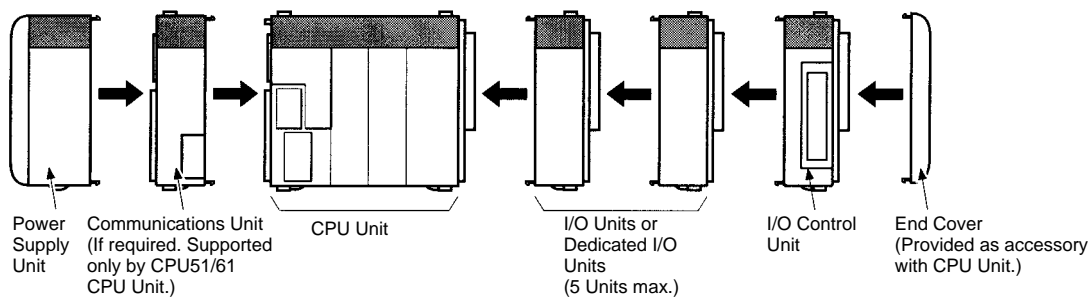

Expansion I/O Block

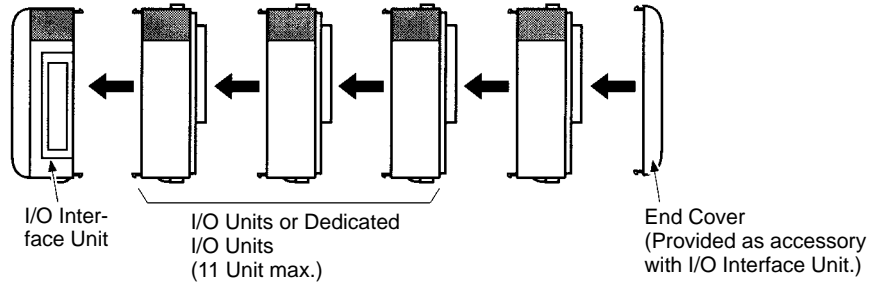

There is no Backplane for the CQM1H. The PC is constructed by connecting Units together using the connectors on the sides.

Caution Attach the End Cover to the Unit on the far right side of the PC. The PC will not operate properly if the End Cover is not connected.

CPU Unit	CPU Block Only		CPU Block and Expansion I/O Block			
	Communications Unit	I/O and Dedicated I/O Units	CPU Block			Expansion I/O Block
			Communications Unit	Inner Boards	I/O and Dedicated I/O Units	I/O and Dedicated I/O Units
CQM1H-CPU61	1	11 max. (See note 1.)	1	2 max.	5 max. (See note 2.)	11 max. (See note 3.)
CQM1H-CPU51						
CQM1H-CPU21	Cannot be connected.		Cannot be connected.	Cannot be mounted.		
CQM1H-CPU11						

- Note**
1. The connected Units (CPU Unit, Communications Unit, Inner Boards, I/O Units, and Dedicated I/O Units) must be selected so that the maximum current capacity of the Power Supply Unit is not exceeded.
 2. The connected Units (CPU Unit, Communications Unit, Inner Boards, I/O Units, Dedicated I/O Units, and I/O Control Unit) must be selected so that the current consumption does not exceed 3.0 A.
 3. The connected Units (I/O Interface Unit, I/O Units, and Dedicated I/O Units) must be selected so that the current consumption does not exceed 2.0 A.
 4. The combined current consumption of the CPU Block and the Expansion I/O Block must not exceed 5 A.
 5. An Analog Power Supply Unit must be counted as a Unit, just like the I/O and Dedicated I/O Units.

4-5 Inner Board Installation

Use the following procedure to mount Inner Boards in the CPU Unit.

- 1, 2, 3...** 1. Press the catch at the top of the Inner Board compartment cover.

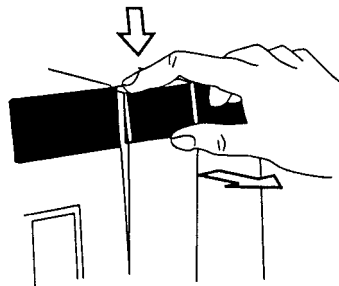

Press the top catch.

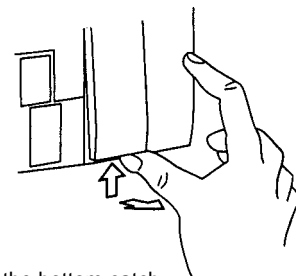

Press the bottom catch.

2. Remove the Inner Board compartment cover.

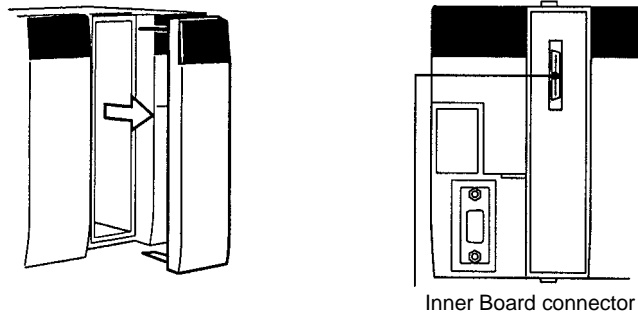

3. Mount the Inner Board.

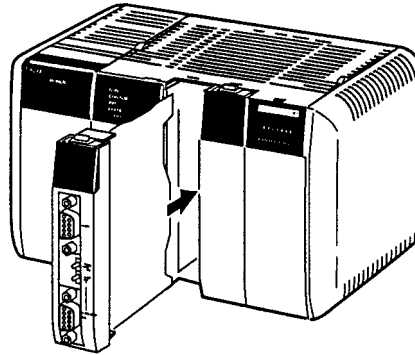

! Caution Always turn the power OFF before installing or removing the Inner Board. Installing or removing the Inner Board with the power ON can cause the CPU Unit to malfunction, damage internal components, or cause communications errors.

! Caution Before installing the Inner Board, be sure to first touch a grounded metallic object, such as a metal water pipe, in order to discharge any static build-up.

4-6 DIN Track Installation

Use the following procedure to install a CQM1H PC on DIN Track.

- 1, 2, 3...**
1. Mount the DIN Track securely to the control board or inside the control panel using screws in at least 3 separate locations.
 2. Release the pins on the backs of the CQM1H Units. These pins lock the PC to the DIN Track.

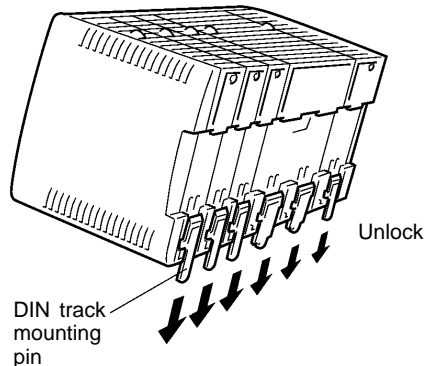

3. Fit the back of the PC onto the DIN Track by inserting the top of the track and then pressing in at the bottom of the PC, as shown below.

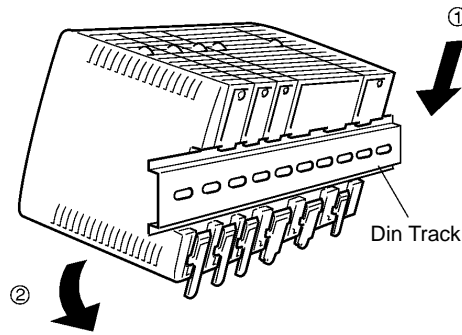

4. Lock the pins on the backs of the CQM1H Units.

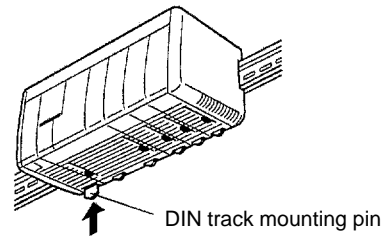

5. Install a DIN Track End Bracket on each side of the PC. To install a Bracket, hook the bottom of the Bracket on the bottom of the track, rotate the Bracket to hook the top of the Bracket on the top of the track, and then tighten the screw to lock the Bracket in place.

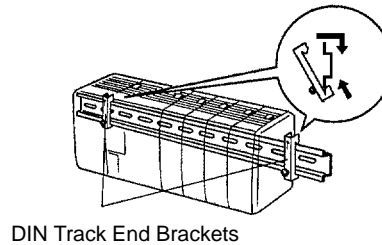

DIN Track and Accessories

Use the DIN Track and DIN Track End Brackets shown below.

DIN Track
 Model numbers: PFP-50N (50 cm),
 PFP-100N (100 cm), PFP-100N2 (100 cm)

DIN Track End Brackets (2 required)
 Model number: PFP-M

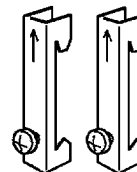
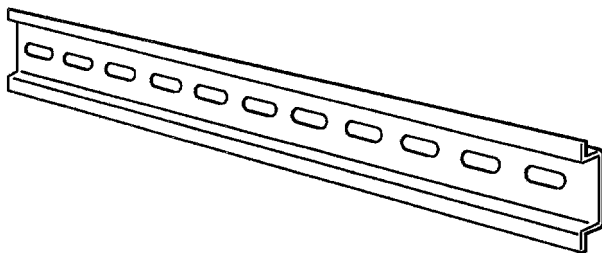

4-7 Wiring and Connections

This section provides basic information on wiring the Power Supply Unit and I/O Units, and on connecting Programming Devices.

4-7-1 Power Supply Unit Wiring

- ! WARNING** Do not attempt to take any Unit apart while the power is being supplied. Doing so may result in electric shock.
- ! Caution** Disconnect the LG terminal of the Power Supply Unit when performing dielectric strength tests.
- ! Caution** Use crimp connectors for wiring. Do not connect bare stranded wires directly to terminals.
- ! Caution** Do not remove the seal from the top of the Power Supply Unit until wiring has been completed. Remove the seal before operating the Unit to prevent overheating.

AC Power Supply Unit Wiring

The following diagram shows the proper connections to an AC power supply. The AC voltage should be between 100 and 240 V AC (50 to 60 Hz). Refer to 3-2-2 *Selecting a Power Supply Unit* for details on Power Supply Unit capacity.

- ! WARNING** Do not touch any of the terminals while the power is being supplied. Doing so may result in electric shock.
- ! Caution** Tighten the AC power terminal screws to a torque of 0.8 N • m. Loose terminal screws can cause fires or errors in operation.

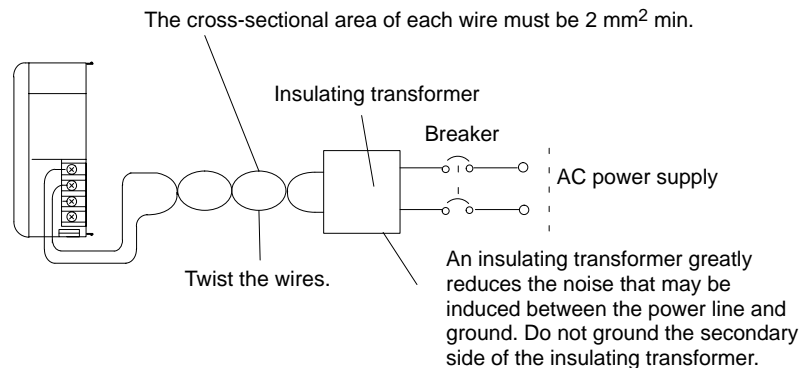

- ! Caution** Be sure that the AC power supply voltage remains within the allowable voltage range. For details refer to 2-1-1 *Power Supply Units*.

The CQM1-PA216 Power Supply Unit is switchable with an input voltage range of 80 to 138 V AC or 160 to 264 V AC. Refer to 3-2-2 *Selecting a Power Supply Unit* for details.

Crimp Connectors

Use round M3.5 crimp connectors of the dimensions shown below for wiring AC Power Supply Units.

- Note** Always use crimp connectors for wiring. Do not connect bare stranded wires directly to terminals.

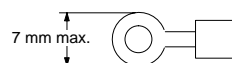

Terminal Blocks

The following diagram shows the terminal blocks for the AC Power Supply Units.

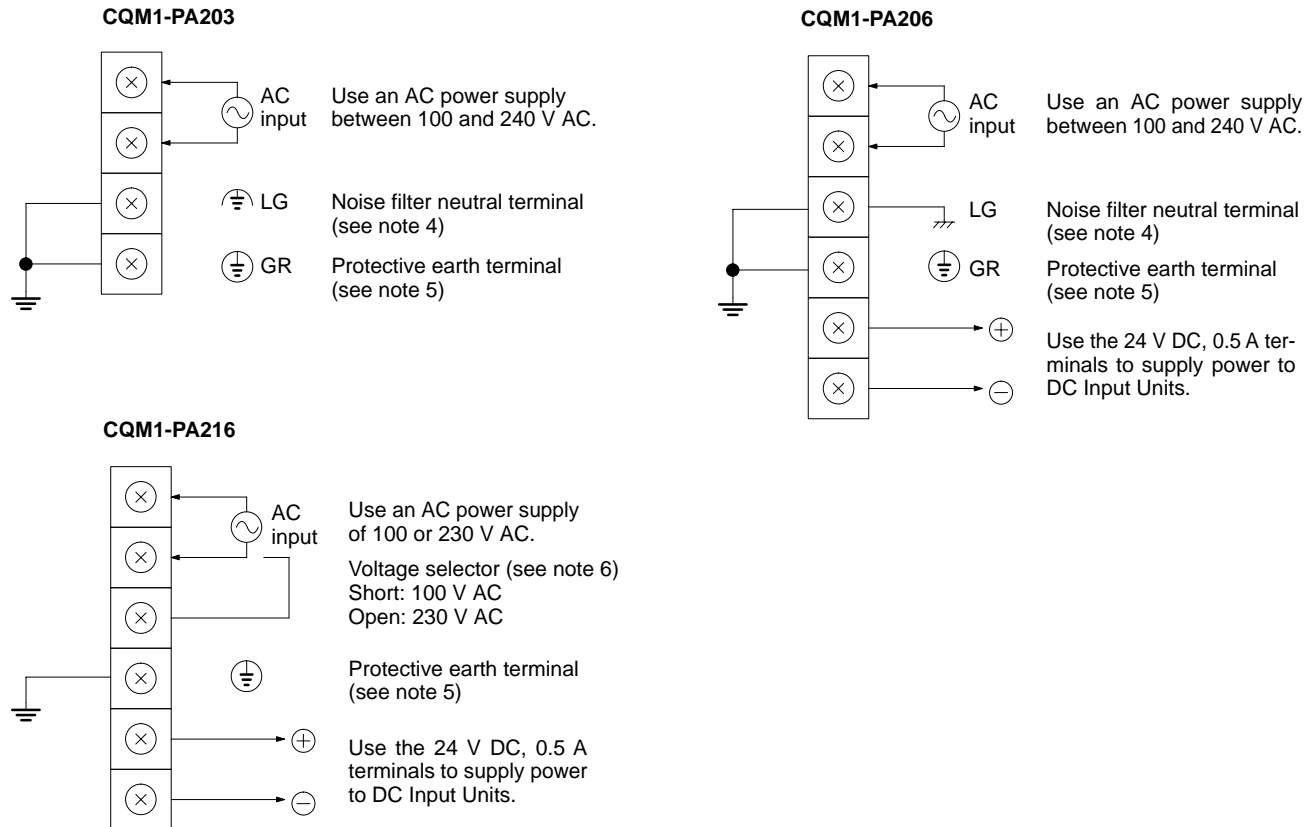

- Note**
- The wire used should be at least 2 mm².
 - Provide the grounding point as close to the CQM1H PC as possible.
 - Tighten the terminal screws to a torque of 0.8 N • m.
 - LG (⏏ or ⏚):
Noise filter neutral terminal. Short-circuit the LG (⏏ or ⏚) terminal and GR (⏚) terminals using the short-circuit bar and ground them at a resistance of less than 100 Ω to reduce noise and prevent electric shock.
 - GR (⏚):
Protective earth terminal. Connect to a separate ground wire of at least 2 mm² to ground the terminal at a resistance of less than 100 Ω to prevent electric shock.
 - When supplying voltage at 100 V AC with the CQM1-PA216, the voltage selector terminals must be shorted, and when supplying voltage at 230 V AC the must be open. When power is supplied at 230 V AC using the CQM1-PA216, remove the short-circuit bar (provided as an accessory) that shorts the voltage selector terminals. The Unit will be damaged if 230 V AC is supplied with the short-circuit bar connected.

DC Power Supply Unit Wiring

The following diagram shows the proper connections to a DC power supply. Use a 24-V DC power supply. Refer to 3-2-2 *Selecting a Power Supply Unit* for details on Power Supply Unit capacity.

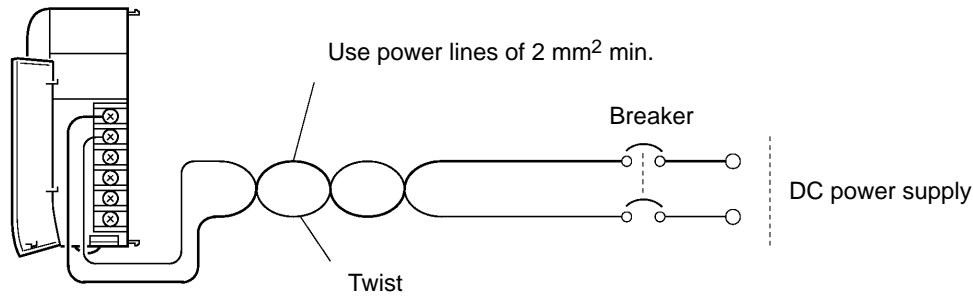

Caution Be sure that the DC power supply voltage remains within the allowed fluctuation range of 20 to 28 V DC.

Crimp Connectors

Use M3.5 crimp connectors of the dimensions shown below for wiring DC Power Supply Units.



Note Always use crimp connectors for wiring. Do not connect bare stranded wires directly to terminals.

Terminal Block

The following diagram shows the terminal block for the DC Power Supply Unit.

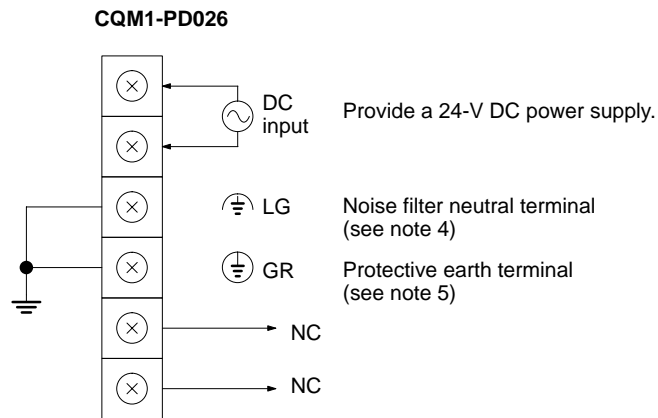

- Note**
1. The wire used should be at least 2 mm².
 2. Provide the grounding point as close to the CQM1H PC as possible.
 3. Tighten the terminal screws to a torque of 0.8 N • m.
 4. LG (⊕):
Noise filter neutral terminal. Short-circuit the LG (⊕) terminal and GR (⊕) terminals using the attached short-circuit bar and ground them at a resistance of less than 100 Ω to reduce noise and prevent electric shock.
 5. GR (⊕):
Protective earth terminal. Connect to a separate ground wire of at least 2 mm² to ground the terminal at a resistance of less than 100 Ω to prevent electric shock.
 6. To satisfy the EC directives (low-voltage directive), provide reinforced insulation or double insulation for the power supply.

Wiring Precautions for Ground Wires

Wire the grounding wires according to the diagram below.

In order to improve the electromagnetic compatibility (EMC), connect the LG (⏏ or ⏚) terminal to the screw on the end plate using the DIN-track connecting cable provided.

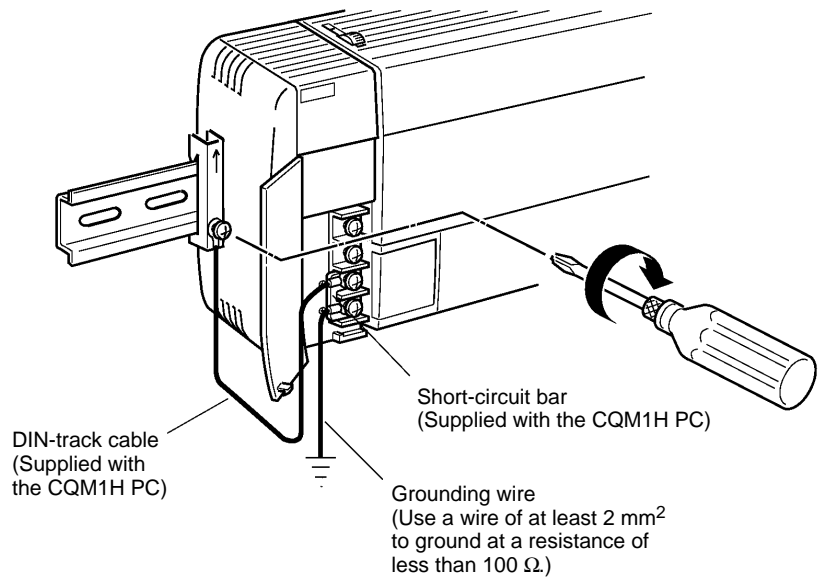

Note Definition of EMC:

The EMC refers to the capacity of equipment represented in terms of emission, which indicates the degree to which electromagnetic waves produced by equipment do not affect other communications equipment, and also in terms of immunity, which indicates the degree of resistance against electromagnetic disturbance.

Caution Do not share grounds with other equipment or attaching to the beam of a building. Improper grounding will cause adverse results.

Correct

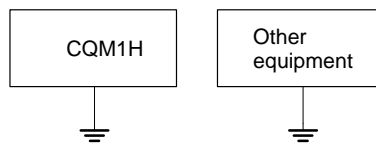

Incorrect

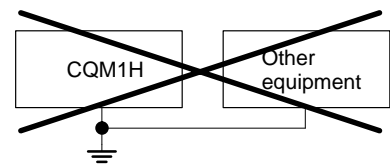

4-7-2 Connecting the CPU Block and Expansion I/O Block

Expansion I/O Cable

A CS1-series Expansion I/O Cable must be used. One of these cables is shown below.



Name	Model	Specifications
Expansion I/O Cable	CS1W-CN313	Length: 0.3 m
	CS1W-CN713	Length: 0.7 m

Note A cable longer than 0.7 m cannot be used.

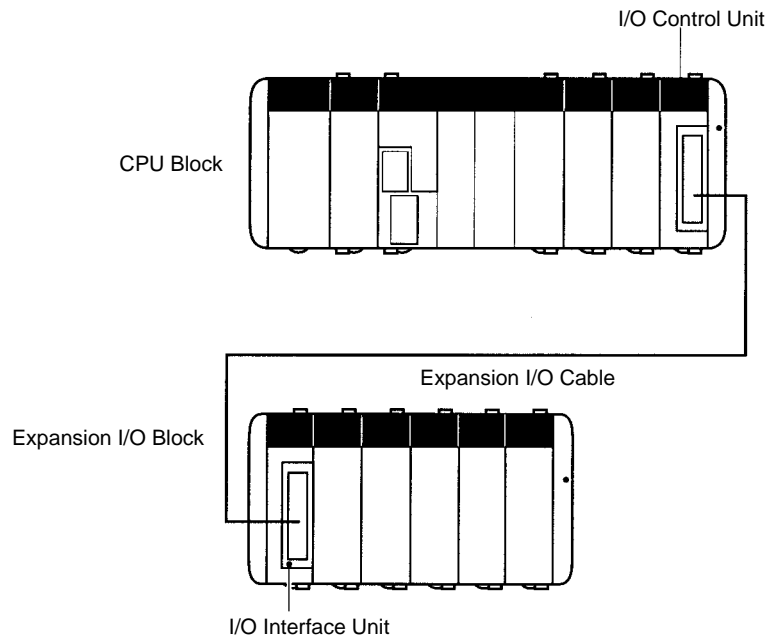

Connecting the Cable

Connect the I/O Control Unit on the CPU Block to the I/O Interface Unit on the Expansion I/O Block.

Connecting the Connectors

Press the locks on both sides of the connector and press in firmly until the connector locks into place. I/O bus errors will occur and operation will stop if the connector is not corrected properly.

Removing the Connectors

Press the locks on both sides of the connector until it releases and pull the connector straight out.

Cable Bending Radius

The maximum bending radius of the Expansion I/O Cable is 69 mm.

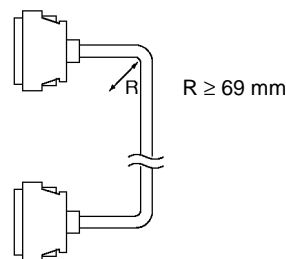

Note Place the Expansion I/O Cable into a separate duct from power lines and I/O lines to protect it from noise.

4-7-3 I/O Unit Wiring

Input Devices

When connecting an external device with a DC output to a DC Input Unit, wire the device as shown in the following table.

Device	Circuit Diagram
Contact output	
NPN open collector	
NPN current output	<p>Use the same power supply for the input and sensor.</p>
PNP current output	
Voltage output	

Terminal Block I/O Units with Terminal Block

The I/O Unit's terminal blocks are removable. Make sure that the connector tabs are locked in the vertical position, as shown in the following diagram. Although

the terminal block position of the CQM1-OC224 is different, the removal method is the same.

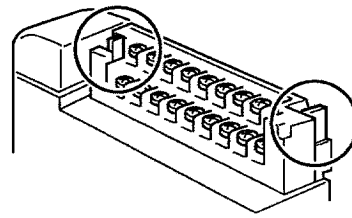

Note Confirm that the terminal block is securely locked before use.

To remove the terminal block, push the connector tabs to the sides and lift the terminal block off the connector, as shown in the following diagram.

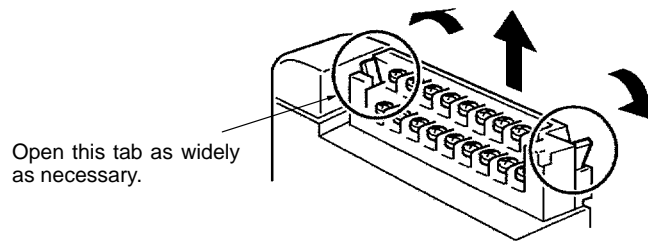

Crimp Connectors

Use M3 crimp connectors of the dimensions shown below for wiring terminal block-type I/O Units.



Note Tighten the terminal screws to a torque of 0.5 N • m.

Caution Crimp connectors are required by UL and CSA standards.

I/O Units with Connectors

Connect either a cable prepared by the user or a dedicated cable to the I/O Unit connectors.

Name	No. of points	Specifications	Model
DC Input Unit	32	12 V DC (32 points per common)	CQM1-ID112
		24 V DC (32 points per common)	CQM1-ID213 CQM1-ID214
Transistor Output Unit	32	4.5 V DC, 16 mA to 26.4 V, 100 mA	CQM1-OD213
		24 V DC, 500 mA, PNP	CQM1-OD216

Connector Position

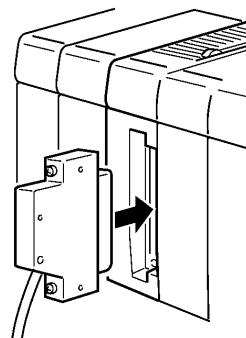

Note When using a cable connector with a locking mechanism, check that the lock is secure before use.

Prepare a cable for use with connector-type I/O Units (32-point Input or Output Units) in one of the following ways:

- Prepare a cable using a soldered-type socket and a connector cover (provided as accessories).
- Prepare a cable using a crimp-type or pressure-welded-type socket and a connector cover (purchased separately).
- Use an OMRON Terminal Block Conversion Unit dedicated cable or an I/O relay terminal connector cable.

4-7-4 Preparing Cables for 32-point Input and Output Units

Prepare cables for connectors on 32-point Input and Output I/O Units (CQM1-ID112, CQM1-ID213, CQM1-ID214 and CQM1-OD213, CQM1-OD216) as explained below.

Recommended Connectors (Cable Side)

Connector type	Model (by Fujitsu)	Set (from OMRON)
Soldered	Socket: FCN-361J040-AU Connector cover: FCN-360C040-J2	C500-CE404
Crimp	Housing: FCN-363J040 Contact: FCN-363J-AU Connector cover: FCN-360C040-J2	C500-CE405
Pressure welded	FCN-367J040-AU/F	C500-CE403

A soldered-type socket and connector cover are provided with each I/O Unit.

Recommended Wire

Use AWG26 to 24 (0.2 to 0.13 mm²) wire for connecting to all of the connector pins.

Note For details on pin arrangement and the internal circuitry of connectors at the CQM1H side, refer to the sections on DC Input Units (32 points) and Transistor Output Units (32 points) in this manual.

Wiring and Assembly

The following illustrations show the procedure for wiring and assembly of solder-type connectors. First pass the electrical wires through heat-shrinking tubes and solder them to the socket pins.

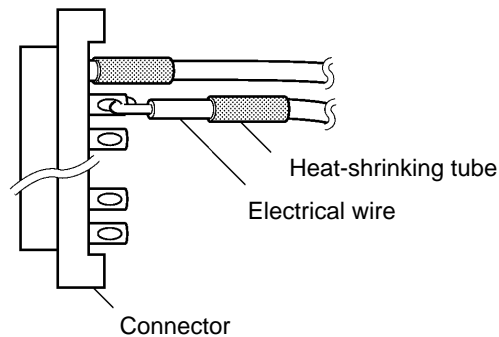

After soldering all of the necessary pins, slide the heat-shrinking tubes over the soldered areas of the respective wires. Then shrink the tubes by heating them with a jet of hot air.

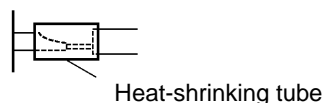

Finally, assemble the socket and connector cover as shown below.

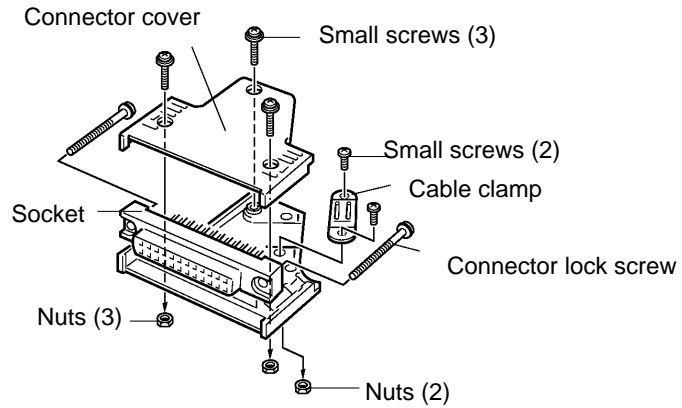

Preassembled Cables

The following examples show applications for preassembled OMRON Cables. Contact your OMRON representative for details.

1, 2, 3... 1. Connecting to a terminal block.

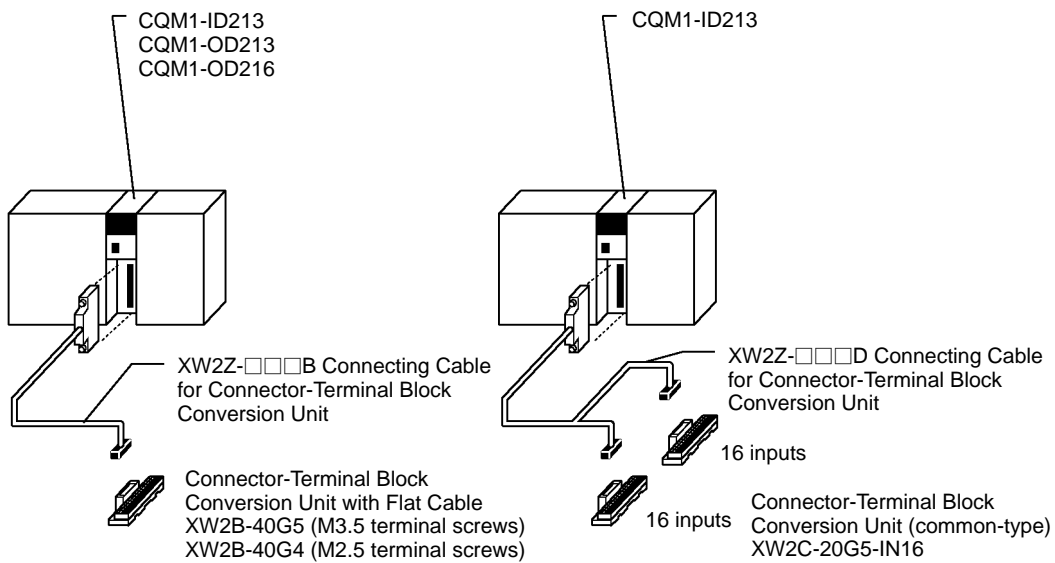

2. Connecting to a Relay Terminal.

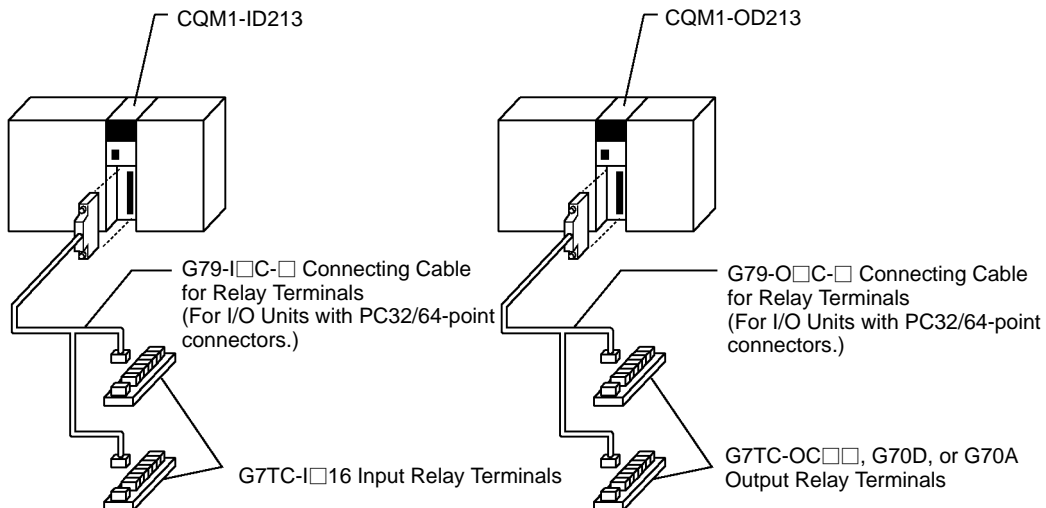

4-8 I/O Unit Wiring Precautions

- ⚠ Caution** Do not remove the protective label from the top of the Unit until wiring has been completed. This label prevents wire strands and other foreign matter from entering the Unit during wiring procedures. Remove the label after the completion of wiring to ensure proper heat dissipation. Leaving the label attached may result in malfunction.
- ⚠ WARNING** Do not touch any of the terminals while the power is being supplied. Doing so may result in electric shock.
- ⚠ Caution** Tighten the terminal screws to a torque of 0.5 N • m.
- ⚠ Caution** Always use crimp connectors for wiring. Do not connect bare stranded wires directly to terminals.
- ⚠ Caution** To satisfy the EC directives (low-voltage directive), provide reinforced insulation or double insulation on the I/O Units' DC power supply.
- ⚠ Caution** Install external breakers and take other safety measures against short-circuiting in external wiring. Insufficient safety measures against short-circuiting may result in burning.
- ⚠ Caution** Double-check all the wiring before turning ON the power supply. Incorrect wiring may result in burning.
- ⚠ Caution** Do not apply voltages exceeding the input voltages to Input Units or voltages exceeding the switching capacity to Output Units. Doing so may result in damage or destruction of the I/O Unit or result in fire.

Leakage Current (24 V DC)

When two-wire sensors, such as photoelectric sensors, proximity sensors, or limit switches with LEDs, are used, the input bit may be turned ON erroneously by leakage current. If the leakage current exceeds 1.3 mA, insert a bleeder resistor in the circuit to reduce the input impedance, as shown in the following diagram.

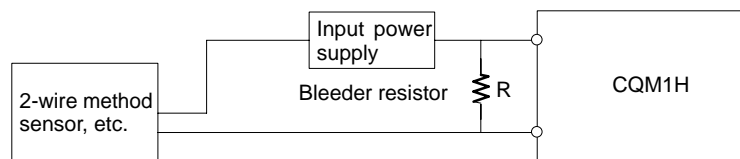

$$R = 7.2 / (2.4 I - 3) \text{ k}\Omega \text{ max.} \quad I: \text{ Device's leakage current (mA)}$$

$$W = 2.3 / R \text{ W min.} \quad R: \text{ Bleeder resistance (k}\Omega)$$

$$\quad \quad \quad W: \text{ Bleeder resistor's power rating (W)}$$

The equations above were derived from the following equation:

$$I \times \frac{R \times \text{Input voltage (24)}}{\text{Input current (10)}} \leq \text{OFF voltage (3)}$$

$$R + \text{Input current (10)}$$

$$W \geq \text{Input voltage (24)} / R \times \text{Input voltage (24)} \times \text{margin (4)}$$

Inrush Current

The following diagram shows two methods that can be used to reduce the large inrush current caused by certain loads, such as incandescent light bulbs.

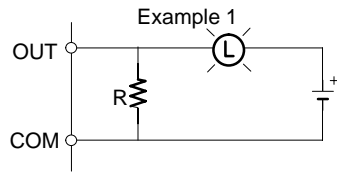

Generating a dark current (about 1/3 of the rated current) through the incandescent bulb.

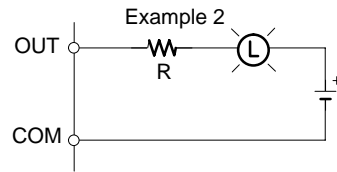

Inserting a regulating resistance.

Be careful not to damage the output transistor.

Reducing Noise in I/O Signals

Whenever possible, place I/O signal lines and power lines in separate ducts or raceways both inside and outside of the control panel.

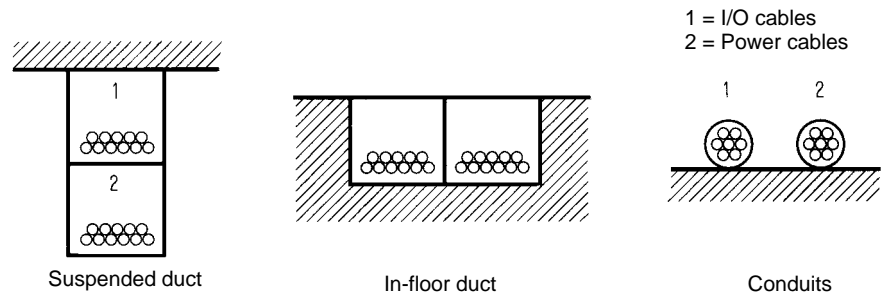

If the I/O wiring and power wiring must be routed in the same duct, use shielded cable and connect the shield to the GR terminal to reduce noise.

Inductive Loads

When an inductive load is connected to an I/O Unit, connect a surge suppressor or diode in parallel with the load as shown below.

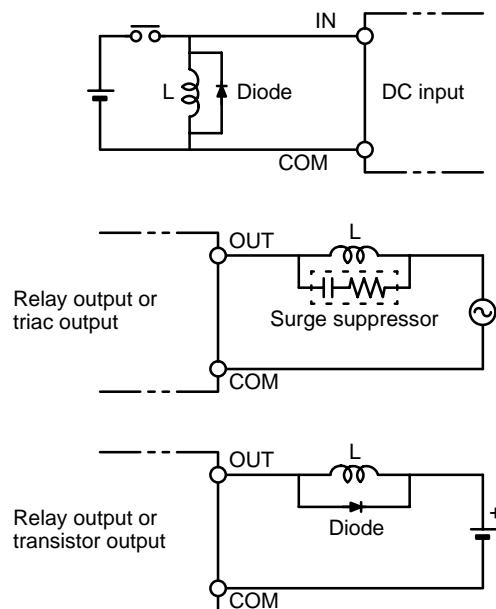

Note Use surge suppressors and diodes with the following specifications.

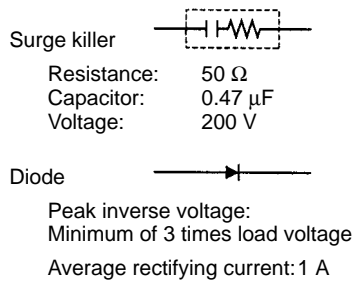

4-9 Connecting Programming Devices

Programming Devices can be connected to the CQM1H. When connecting to the peripheral port, be sure to insert the connector securely.

Host Computer Connection

The CQM1H CPU Unit can be connected to an IBM PC/AT compatible computer running Support Software using a compatible connecting cable.

Note When connecting the CQM1H to Support Software, turn ON pin 7 on the DIP switch. If pin 7 is OFF, it will not be possible to use Support Software and only Programming Console connections will be supported. When communicating via a peripheral bus, it is also necessary to turn OFF pin 5 on the DIP switch and make the communications settings in the PC Setup for Host Link. For details refer to 3-6 *Programming Devices*.

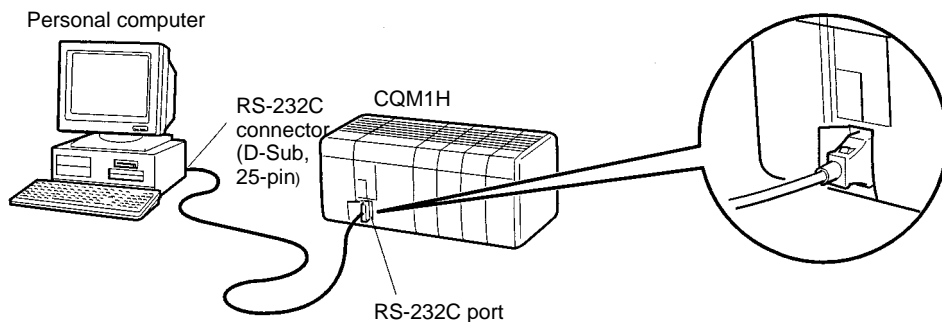
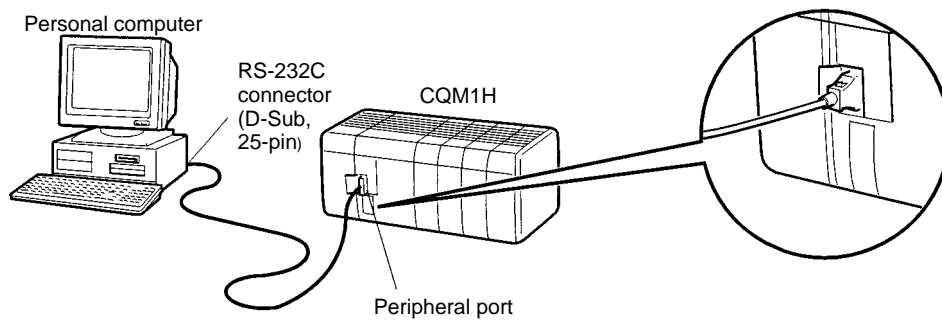

Programming Console Connection

The CQM1H CPU Unit can be connected to a Programming Console as shown below.

Note When connecting the CQM1H to a Programming Console, be sure to turn OFF pin 7 on the DIP switch (factory setting). If pin 7 is ON, it will not be possible to use a Programming Console.

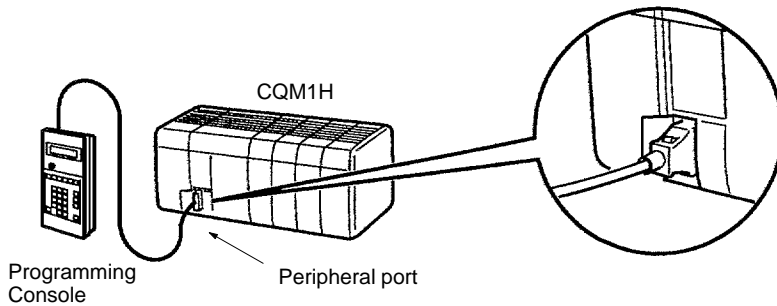

4-10 Connecting Programmable Terminals

The different communications configurations available for communications with a Programming Terminal (PT) are shown in the following table.

Serial communications port		Serial communications mode	PC-to-PT ratio	Programming Console functions
CPU Unit's built-in RS-232C port		NT Link (1:1 mode)	One-to-one only	Supported (from PT)
Serial Communications Board	RS-232C port (port 1)	NT Link (1:1 mode, 1:N mode)	One-to-one or one-to-many	No
	RS-422A/485 (port 2)	NT Link (1:1 mode, 1:N mode)	One-to-one or one-to-many	No

- Note**
1. When communicating via a 1:1-mode NT Link, connect to the port on the PT that supports this mode. Communications will not be possible if connection is made to a port that supports only 1:N-mode communications.
 2. When communicating via a 1:N-mode NT Link, connect to the port on the PT that supports this mode. Communications will not be possible if connection is made to a port that does not support this mode (e.g., the RS-232C port on the NT30/NT30C supports only 1:1 communications).
 3. The NT20S, NT600S, NT30, NT30C, NT620S, NT620C, and NT625C cannot be used if the cycle time of the CPU Unit is 800 ms or longer (even if only one of these PTs is used in a 1:N NT Link.)
 4. The Programming Console functions of the PT (Expansion Mode) cannot be used when connected to Serial Communications Board ports. They can be used only by connecting to the RS-232C port on the CPU Unit.
Turn ON pin 7 on the DIP switch on the CPU Unit when using the Programming Console function of the PT.
 5. Set a unique unit number for each PT connected to the same PC. If the same unit number is set for more than one PT, malfunctions will occur.

Use the following cables to connect to the PT. For details, refer to the relevant operation manual.

Cables for 1:1 Connections between PC and PT

PC Unit or Board	PC port	PT	PT port	Serial communications mode (see note)	Length	Model
CPU Unit or Serial Communications Board For the CPU Unit, the mode will be 1:1, for the Serial Communications Board, the mode will be 1:1 or 1:N.	RS-232C port (D-Sub, 9-pin, female)	NT20S, NT600S, NT620S, NT620C, NT625C	RS-232C port (D-Sub, 9-pin, female)	Host Link or NT Link (1:1 mode or 1:N mode)	2 m	XW2Z-200T
					5 m	XW2Z-500T
		NT30, NT30C	RS-232C port (D-Sub, 9-pin, female)	Host Link or NT Link (1:1 mode)	2 m	XW2Z-200T
					5 m	XW2Z-500T
		NT31, NT31C, NT631, NT631C	Port A: RS-232C port (D-Sub, 9-pin, female)	Host Link or NT Link (1:1 mode or 1:N mode)	2 m	XW2Z-200T
					5 m	XW2Z-500T
			Port B: RS-232C port (D-Sub, 25-pin, female)	Host Link or NT Link (1:1 mode or 1:N mode)	2 m	XW2Z-200S
					5 m	XW2Z-500S
		NT20M, NT600M, NT610G, NT612G, NT610C	RS-232C port (D-Sub, 25-pin, female)	Host Link	2 m	XW2Z-200S
					5 m	XW2Z-500S

Note For details of connections to the RS-422A/485 port on the Serial Communications Board, refer to the relevant operation manual.

Automatic Mode Change

When the PC is in RUN mode with a Programming Console connected to the peripheral port of the CPU Unit, if a PT is connected to the CPU Unit's built-in RS-232C port or either of the ports of a CQM1H-SCB41 using Host Link mode, the following message will be displayed at the Programming Console indicating that a password is required to continue operation (using the Programming Console).

```
<MONITOR>
PASSWORD!
```

This is because, in order to write data to the CPU Unit, the PT changed the operation mode from RUN mode to MONITOR mode. To continue operation using the Programming Console, it is necessary to input the password again.

Inputting the Password



- The mode will not be changed if the PT is connected via an NT Link.
- When a Programming Device installed on a computer is connected to the peripheral port, the display (at the computer) for the CPU Unit's operation mode will simply change from "RUN" to "MONITOR."

SECTION 5

Overview of Operation

This section gives a general overview of CQM1H operation and includes details on the internal structure of the CPU Unit and describes the different operating modes.

- 5-1 Internal Structure of CPU Unit
- 5-1-1 Memory Areas
- 5-1-2 DIP Switch
- 5-1-3 Memory Cassette
- 5-2 Operating Modes
- 5-2-1 Description of Operating Modes
- 5-2-2 Initialization of I/O Memory
- 5-2-3 Startup Mode
- 5-2-4 Operation without a Battery

5-1 Internal Structure of CPU Unit

The following diagram shows the internal structure of the CPU Unit.

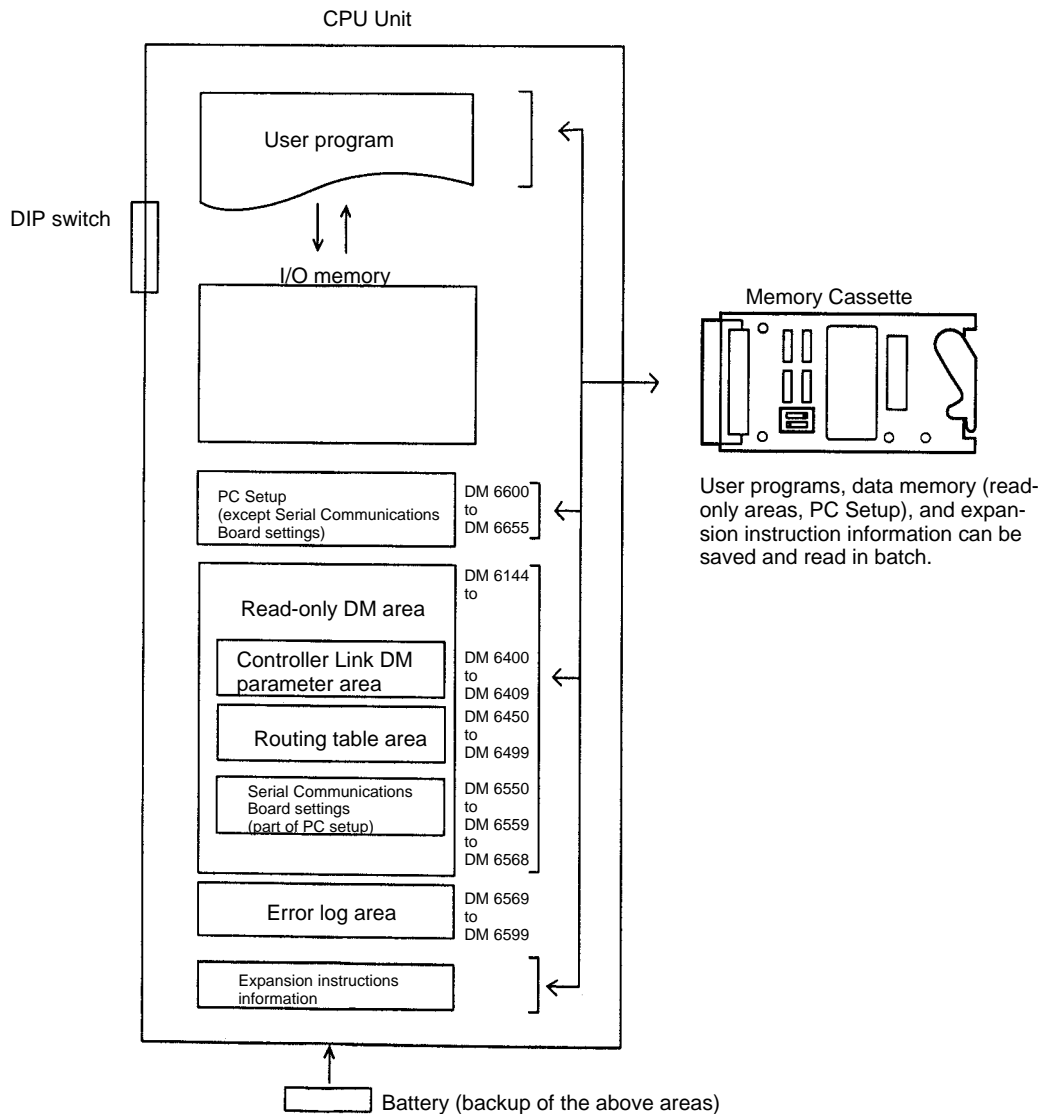

Note There are no I/O tables registered by the user for the CQM1H.

5-1-1 Memory Areas

All of the following areas are backed up using the battery. If the battery expires the data for these areas will be lost.

The User Program

The user program is made up of program instructions. These instructions read and write to I/O memory and are executed in order starting at the top of the program. After all instructions are executed, the I/O for all Units are refreshed, and the cycle repeats again from the top of the program.

If pin 1 on the DIP switch on the front of the CPU Unit is set to ON, the user program cannot be written from a Programming Device.

Reading, writing, and comparison can be performed on the user program when a Memory Cassette is used.

I/O Memory

I/O memory is the area used for reading and writing from the user program or a Programming Device. It is comprised of both areas that are cleared when power is turned OFF and ON, and areas that will retain data.

	I/O memory is also partitioned into areas that exchanges data with all Units and areas strictly for internal use. There are four times at which data can be exchanged with Units: Once per instruction execution cycle, on the execution of the I/O refresh instruction IORF(97), input refreshing when an interrupt input is received, and immediate refresh of outputs on execution of instructions.
PC Setup (DM 6600 to DM 6655)	The PC Setup is used to set various initial or other settings through software switches or parameters. Reading, writing, and comparison can be performed on this area using a Memory Cassette.
Read-only Area (DM 6144 to DM 6568)	This area can be read by, but not written from, the user program. A Programming Device must be used to write to this area. If pin 1 on the DIP switch on the front of the CPU Unit is ON, a Programming Device will also not be able to write to this area. The data in this area is retained when the power is turned OFF. This area includes the Controller Link DM parameter area, the routing table area, and Serial Communications Board settings area. Reading, writing, and comparison can be performed on this area using a Memory Cassette.
Error Log (DM 6569 to DM 6599)	The error log stores the times of occurrence and error codes of both fatal and non-fatal errors that occur in the CPU Unit. Up to 10 errors can be stored.
Expansion Instruction Information	This area contains the function code allocations for expansion instructions (instructions for which function codes can be changed or allocated). If pin 4 on the DIP switch on the front of the CPU Unit is OFF, the default allocations for the expansion instructions will be used. These allocations cannot be changed while pin 4 is set to OFF. Reading, writing, and comparison can be performed on this area using a Memory Cassette.

5-1-2 DIP Switch

The DIP switch is used to set initial or other settings.

5-1-3 Memory Cassette

The user program, data memory (read-only area and PC Setup), and expansion instruction information can be saved using the Memory Cassette. If pin 2 on the DIP switch on the front of the CPU Unit is ON, the data stored in the Memory Cassette is automatically transferred to the CPU Unit when power is turned ON.

5-2 Operating Modes

5-2-1 Description of Operating Modes

The following 3 operating modes are available in the CPU Unit. These modes control the entire user program.

PROGRAM Mode	Program execution stops in PROGRAM mode. This mode is used for the following operations: <ul style="list-style-type: none"> • Changing PC Setup and other settings. • Transferring and checking programs. • Force-setting and resetting bits to check wiring and bit allocation. I/O refreshing is performed in PROGRAM mode.
MONITOR Mode	The following operations can be performed while the program is executing in MONITOR mode. This mode is used to make test runs or other adjustments. <ul style="list-style-type: none"> • Online editing. • Force-setting and force-resetting bits. • Changing values in I/O memory.
RUN Mode	This mode is used for normal program execution. Some Programming Device operations like online editing, force-set/force-reset, and changing I/O memory

values are disabled in this mode, but other Programming Device operations like monitoring the status of program execution (monitoring programs and monitoring I/O memory) are enabled. This mode is used for actual operation.

 **Caution** Confirm that there will be no adverse effects on equipment before changing the operating mode.

5-2-2 Initialization of I/O Memory

The following table shows which data areas will be cleared when the operating mode is changed from PROGRAM mode to RUN/MONITOR mode or vice-versa.

Mode change	Non-held Areas (Note 1)	Held Areas (Note 2)
RUN/MONITOR → PROGRAM	Cleared (See notes 3 and 5)	Retained
PROGRAM → RUN/MONITOR	Cleared (See notes 4 and 5)	Retained
RUN ↔ MONITOR	Retained	Retained

- Note**
1. Non-held areas: IR area, LR area, Timer PVs, Timer Completion Flags. (The statuses of some addresses in the AR area and SR area are held and others are cleared.)
 2. Held areas: HR area, DM area, EM area, Counter PVs, and Counter Completion Flags.
 3. The status of Timer PVs and Timer Completion Flags will be held when the operating mode is changed from RUN mode or MONITOR mode to PROGRAM mode.
 4. The status of Timer PVs and Timer Completion Flags will be cleared when the operating mode is changed from PROGRAM mode to RUN mode or MONITOR mode.
 5. Data in I/O memory will be retained when the I/O Hold Bit (SR 25212) is ON. When the I/O Hold Bit (SR 25212) is ON and operation is stopped due to a fatal error (including FALS(07)), the contents of I/O memory will be retained but outputs on Output Units will all be turned OFF. Refer to the *CQM1H Programming Manual* for details on I/O memory.

5-2-3 Startup Mode

The operating mode that the CQM1H starts in when power is turned ON depends on the following three factors: The setting of pin 7 on the DIP switch on the front of the CPU Unit, the PC Setup, and whether or not a Programming Console is connected. The startup mode for different combinations of these factors is shown in the following table.

PC Setup			Operating mode
Word	Bits	Value	
DM 6600	08 to 15	00 Hex	(See note below.)
		01 Hex	Operating mode last used before power was turned OFF
		02 Hex	Operating mode specified in bits 00 to 07
	00 to 07	00 Hex	PROGRAM mode
		01 Hex	MONITOR mode
		02 Hex	RUN mode

Note The startup mode will depend on the setting of pin 7 on the DIP switch and the type of device connected, in the way shown in the following table:

Connected device at power ON	Pin 7 setting	
	OFF	ON
Nothing connected	PROGRAM mode	RUN mode
Programming Console	Determined by Programming Console mode switch	PROGRAM mode (Communications with Programming Console not possible.)
Device other than Programming Console	PROGRAM mode (Communications with connected device not possible.)	Either PROGRAM mode or RUN mode depending on connecting cable. (See note.)

Note The following table shows the relationship between the startup mode and connecting cable when a device other than a Programming Device is connected.

Connecting cable	Startup mode
CS1W-CN114 + CQM1-CIF01/02	PROGRAM mode
CS1W-CN118 + XW2Z-200/500S(-V)	PROGRAM mode
CS1W-CN226/626	RUN mode
CS1W-CN118 + XW2Z-200/500S-CV	RUN mode

5-2-4 Operation without a Battery

Operation is still possible when there is no internal battery, or the internal battery has expired, by writing the required data (user program, PC Setup, etc.) to a Memory Cassette. In this case, turn ON pin 2 on the DIP switch on the front of the CPU Unit so that data stored in the Memory Cassette is transferred to the CPU Unit automatically at startup.

Note If the internal battery expires, the data in the CPU Unit (user program, settings, etc.) will be lost when the power is turned OFF.

Consider the following precautions when operating with no internal battery or with an expired battery.

- When the internal battery expires, data will be affected in the following way.
 - HR area, Timer/Counter PVs, DM area, and AR area data will be cleared when the power is turned OFF.
 - SR area data will become unstable when the power is turned OFF. Therefore, do not set the I/O Hold Bit (SR 25212) and the Forced Status Hold Bit (SR 25211) to be maintained in the PC Setup (DM 6601).
- The I/O Hold Bit (SR 25212), the Forced Status Hold Bit (SR 25211), and the Output OFF Bit (SR 25215) will be particularly unstable and may have an adverse effect on operation. Turn OFF these bits at the start of the program. The following instructions can be used to do this.

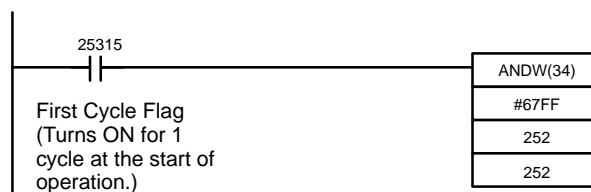

If the setting shown below is made in the PC Setup (DM 6655 bits 12 to 15), battery errors (a non-fatal error) will not be detected even if the internal battery expires.

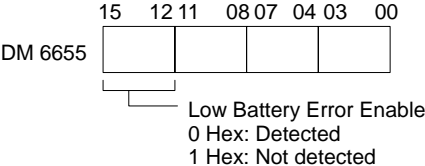

SECTION 6

Switch Settings

This section describes the setting on the DIP switch on the front of the CPU Unit. Most PC operations are controlled by parameters set in the PC Setup. Refer to the *CQMIH Programming Manual* for information on the PC Setup.

6-1	DIP Switch Settings
6-2	Communications Port and Startup Modes Settings

6-1 DIP Switch Settings

The illustration shows the factory settings of the DIP switch. The factory settings are also given in bold in the following table.

The tables after the following table provide details different setting combinations for pins 5 and 7.

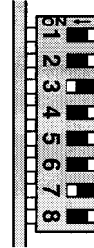

Pin	Usage	Setting	Function
1	Write protection	ON	User program, read-only DM (DM 6144 to DM 6568), and PC Setup (DM 6600 to DM 6655) cannot be written from a Programming Device.
		OFF	User program, read-only DM (DM 6144 to DM 6568), and PC Setup (DM 6600 to DM 6655) can be written from a Programming Device.
2	Auto-transfer from Memory Cassette	ON	Auto-transfer enabled. User programs, read-only DM (DM 6144 to DM 6568), PC Setup (DM 6600 to DM 6655), and expansion instruction information stored on the Memory Cassette will be transferred to the CPU Unit automatically at start-up. If pin 4 is set to OFF, however, expansion instruction information will not be transferred and the default settings will be used.
		OFF	Auto-boot disabled.
3	Programming Console display language	ON	English.
		OFF	The language stored in system ROM. (Messages will be displayed in Japanese with the Japanese version of system ROM.)
4	Expansion instruction setting	ON	Expansion instructions set by user. Normally ON when using a host computer for programming/monitoring. (See note 1.)
		OFF	Expansion instructions set to defaults.
5	Serial communications port settings	ON	Peripheral port and RS-232C port on CPU Unit controlled by standard settings (Host Link, 1 start bit, even parity, 7-bit data, 2 stop bit, 9,600 bps) If pin 7 is set to OFF, however, this setting is ignored for the peripheral port.
		OFF	Peripheral port controlled by PC Setup (DM 6650 to DM 6654) and RS-232C port controlled by PC Setup (DM 6645 to DM 6649).
6	User determined setting	ON	The setting of pin 6 is stored as the ON/OFF status of AR 0712. If pin 6 is ON, AR 0712 will be ON. If pin 6 is OFF, AR 0712 will be OFF.
		OFF	
7	Device connected to peripheral port	ON	Programming Devices other than a Programming Console can be connected to the peripheral port.
		OFF	Only a Programming Console can be connected to the peripheral port.
8 (see note 2)	CX-Protocol enable	ON	Use CX-Protocol for Serial Communications Board.
		OFF	Do not use CX-Protocol for Serial Communications Board.

- Note**
- When pin 4 is ON, it is possible to change the assignment of function codes for expansion instruction. If power is turned ON with pin 4 turned OFF after function code assignments have been changed, the settings will return to the default settings and the information for the expansion instructions that were changed will be lost. Also, if pin 4 is OFF, expansion instruction information will not be transferred from the Memory Cassette.
 - Turn ON pin 8 to use the CX-Protocol to create or modify protocol macros when using a port on a CQM1H-SCB41 Serial Communications Board in the Protocol Macro serial communications mode. Select "C200HG-CPU43" as the CPU Unit on the CX-Protocol.

3. Turn OFF pin 8 before using a personal computer Programming Device (Support Software) for online operations.

6-2 Communications Port and Startup Modes Settings

Effect of Pin 5 and Pin 7 on Peripheral Port and RS-232C Port Operation

Pin		Function	
5	7	Peripheral port	Built-in RS-232C port
OFF	OFF	Programming Console supported.	Communications settings determined by PC Setup (DM 6645 to DM 6649).
OFF	ON	Device other than Programming Console supported. Communications settings determined by PC Setup (DM 6650 to DM 6654).	Communications settings determined by PC Setup (DM 6645 to DM 6649).
ON	OFF	Programming Console supported.	Standard communications settings used.
ON	ON	Device other than Programming Console supported. Standard communications settings used.	Standard communications settings used.

Effect of Pin 5 and Pin 7 on Serial Communications Mode via Peripheral Port

Pin		Serial Communications Mode for peripheral port					
5	7	Programming Console bus	Peripheral bus	Host Link	No-protocol	1:1 Data Link	NT Link (1:1 mode)
OFF	OFF	YES	No				
OFF	ON	No	YES (see note)	YES	YES	No	No
		(Controlled by PC Setup.)					
ON	OFF	YES	No				
ON	ON	No	YES (Standard setting)	YES (Standard setting)	No	No	No

Note When connecting Support Software to the peripheral port via a peripheral bus, use the following settings. The serial communications mode is Host Link.

Pin		PC Setup: DM 6650
5	7	
OFF	ON	0000 Hex (standard settings) or 0001 Hex (custom settings)
ON	ON	Ignored (standard settings)

Effect of Pin 5 and Pin 7 on Serial Communications Mode via Built-in RS-232C Port

Pin		Serial Communications Mode for built-in RS-232C port					
5	7	Programming Console bus	Peripheral bus	Host Link	No-protocol	1:1 Data Link	NT Link (1:1 mode)
OFF	OFF	No	No	YES	YES	YES	YES
		(Controlled by PC Setup.)					
OFF	ON	No	No	YES	YES	YES	YES
		(Controlled by PC Setup.)					
ON	OFF	No	No	YES (Standard setting)	No	No	No
ON	ON	No	No	YES (Standard setting)	No	No	No

Effect of Pin 5 and Pin 7 on the Startup Mode

If the Startup Mode setting in the PC Setup (DM 6600, bits 08 to 15) is set to 00 Hex (Startup Mode governed by setting of pin 7 on the DIP switch), the Startup Mode will be determined by the setting of pin 7 as soon as the presence or absence of a Programming Console connection is determined. The operating mode depends on the PC Setup, the status of DIP switch pin 7, and the device connected to the peripheral port when power is turned ON in the way shown in the following tables.

PC Setup			Operating mode
Word	Bits	Value	
DM 6600	08 to 15	00 Hex	(See note below.)
		01 Hex	Operating mode last used before power was turned OFF
		02 Hex	Operating mode specified in bits 00 to 07
	00 to 07	00 Hex	PROGRAM mode
		01 Hex	MONITOR mode
		02 Hex	RUN mode

Note When bits 08 to 15 in DM 6600 of the PC Setup are set to 00 Hex, the Startup Mode will depend on the setting of pin 7 on the DIP switch and the type of device connected, in the way shown in the following table:

Device connected at power ON	Pin 7	
	OFF	ON
Nothing connected	PROGRAM mode	RUN mode
Programming Console	Determined by Programming Console mode switch	PROGRAM mode (Communications with Programming Console not possible.)
Device other than Programming Console	PROGRAM mode (Communications with connected device not possible.)	Either PROGRAM mode or RUN mode depending on connecting cable. (See note.)

Note The following table shows the relationship between the Startup Mode and connecting cables when a device other than a Programming Console is connected, pin 7 on the DIP switch is set to ON, and bits 08 to 15 in DM 6600 of the PC Setup are set to 00 Hex.

Connecting cables	Startup mode
CS1W-CN114 + CQM1-CIF01/02	PROGRAM mode
CS1W-CN118 + XW2Z-200/500S(-V)	PROGRAM mode
CS1W-CN226/626	RUN mode
CS1W-CN118 + XW2Z-200/500S-CV	RUN mode

SECTION 7

Using a Programming Console

This section provides information on connecting and using a Programming Console. Refer to 7-4-2 *Programming Console Error Messages* for details on errors that might occur during Programming Console operations.

7-1	Programming
7-2	Connecting the Programming Console
7-2-1	Compatible Programming Consoles
7-2-2	Changing the CQM1H's Mode with the Mode Switch
7-2-3	Operating Mode at Startup
7-2-4	Preparation for Operation
7-2-5	Entering the Password
7-3	Programming Console Operations
7-3-1	Overview
7-3-2	Clearing Memory
7-3-3	Reading/Clearing Error Messages
7-3-4	Buzzer Operation
7-3-5	Reading and Assigning Expansion Instruction Function Codes
7-3-6	Setting and Reading a Program Memory Address and Monitoring Bit Status ...
7-3-7	Entering or Editing Programs
7-3-8	Instruction Search
7-3-9	Bit Operand Search
7-3-10	Inserting and Deleting Instructions
7-3-11	Checking the Program
7-3-12	Bit, Digit, Word Monitor
7-3-13	Binary Monitor
7-3-14	Three-word Monitor
7-3-15	Signed Decimal Monitor
7-3-16	Unsigned Decimal Monitor
7-3-17	Differentiation Monitor
7-3-18	Changing Timer, Counter SV
7-3-19	Hexadecimal, BCD Data Modification
7-3-20	Binary Data Modification
7-3-21	Signed Decimal Data Modification
7-3-22	Unsigned Decimal Data Modification
7-3-23	Three-word Data Modification
7-3-24	Force Set, Reset
7-3-25	Clear Force Set/Reset
7-3-26	Hex-ASCII Display Change
7-3-27	Reading and Setting the Clock
7-3-28	Displaying the Cycle Time
7-4	Programming Example
7-4-1	Preparatory Operations
7-4-2	Programming Console Error Messages
7-4-3	Example Program
7-4-4	Programming Procedures
7-4-5	Checking the Program
7-4-6	Test Run in MONITOR Mode

7-1 Programming

When using Programming Consoles for a CQM1H-series PC for the first time, use the following procedure.

- 1, 2, 3...**
1. Turn OFF the power supply to the Power Supply Unit.
 2. Set the DIP switch on the front of the CPU Unit as follows:
 - Pin 7: OFF (for Programming Console connection)
 - Pin 3: ON (for English language displays)

Note Always turn OFF pin 7 before connecting the Programming Console.
 3. Connect the Programming Console to the peripheral port on the CPU Unit.
 4. Set the mode switch on the Programming Console to PROGRAM.
 5. Turn ON the power supply to the Power Supply Unit.

Note Any program in the CPU Unit will be executed when power is turned ON if the operating mode is not set to PROGRAM.
 6. Enter the password. (Press the **CLR** and **MON** Keys.)
 7. Clear all memory.
 8. Read and clear error messages.
 9. Start programming.

7-2 Connecting the Programming Console

A Programming Console can be connected to the CQM1H-series CPU Unit's peripheral port. It cannot be connected to the RS-232C port.

Before connecting the Programming Console, turn OFF pin 7 on the DIP switch on the front of the CPU Unit.

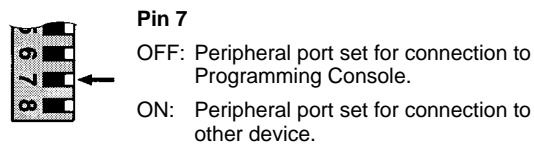

- Note**
1. Do not change the setting of DIP switch pin 7 while a Programming Console is connected. Changing the setting will interrupt communications and cause a communications error. If a Programming Console is connected, it will become unresponsive, key inputs won't be received, and the display will not change.
 2. Refer to 6-1 *DIP Switch Settings* for the settings of other pins.
 3. If the Programming Console's cable is disconnected and then reconnected within 2 seconds, it won't be necessary to reenter the password and the previous display status will remain. In some cases, it won't be necessary to reenter the password if the Programming Console's cable is disconnected while a time-consuming operation (such as a program check) is being performed.

Connecting a CQM1H-PRO01-E

Connect the CQM1H-PRO01-E Programming Console to the CQM1H as shown below.

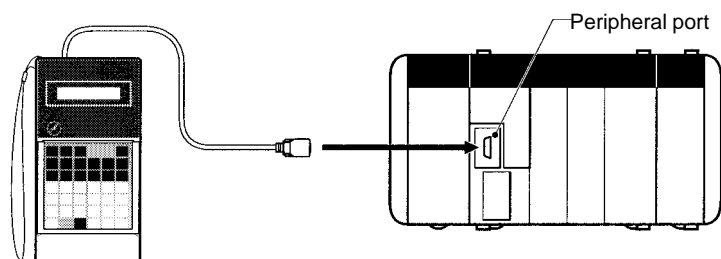

Connecting a CQM1-PRO01-E

Connect the CQM1-PRO01-E Programming Console to the CQM1H as shown below.

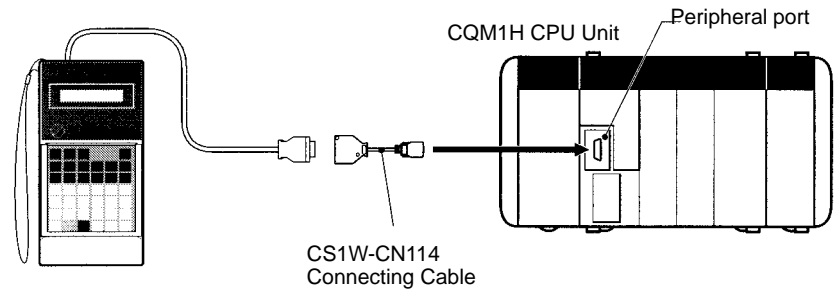

Connecting a C200H-PRO27-E

Connect the C200H-PRO27-E Programming Console to the CQM1H as shown below. Only one Programming Console can be connected at a time.

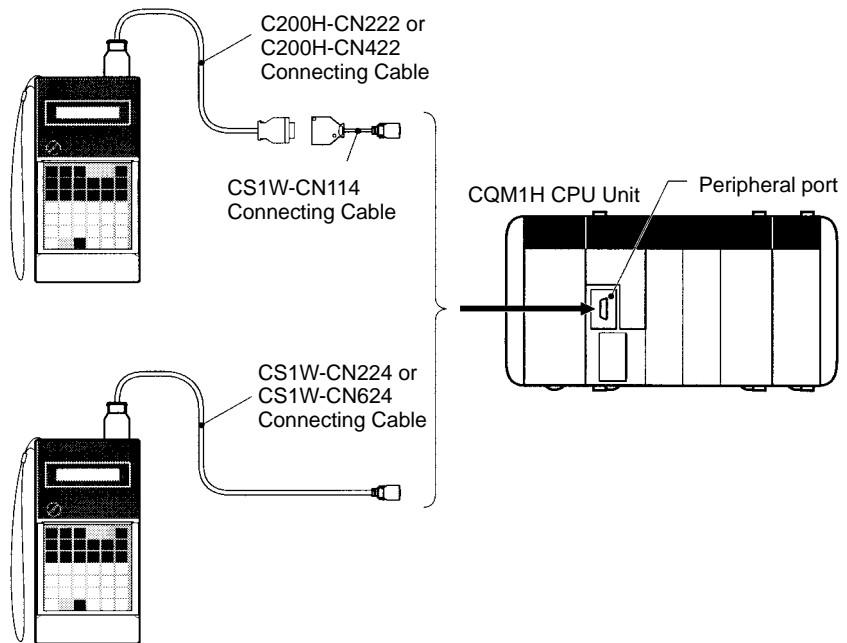

Panel Installation

The C200H-PRO27-E Programming Console can be installed in a control panel as shown in the following diagram. (The C200H-ATT01 Mounting Bracket is sold separately.)

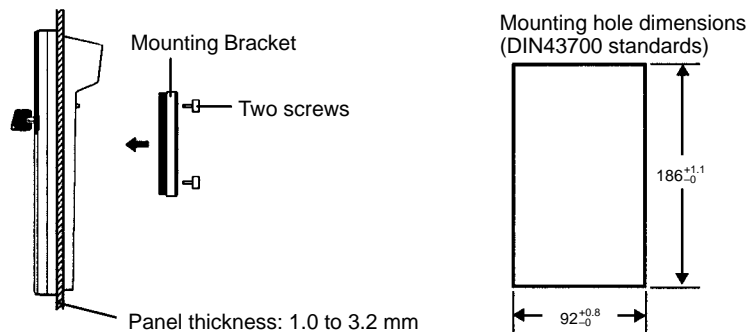

Allow at least 80 mm for the cable connector above the Programming Console.

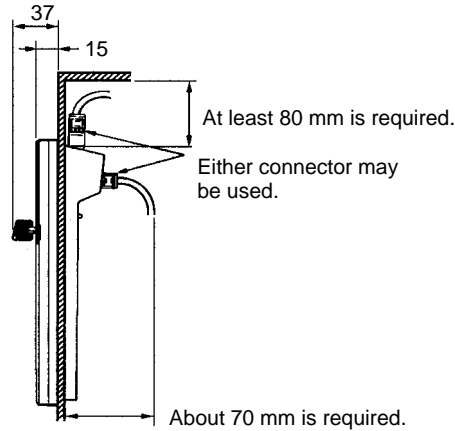

7-2-1 Compatible Programming Consoles

There are two Programming Consoles that can be used with the CQM1H: The CQM1H-PRO01-E, CQM1-PRO01-E and the C200H-PRO27-E. The key functions for these Programming Consoles are identical.

Press and hold the SHIFT Key to input a letter shown in the upper-left corner of the key or the upper function of a key that has two functions. For example, the CQM1H-PRO01-E or CQM1-PRO01-E's AR/HR Key can specify either the AR or HR Area; press and release the SHIFT Key and then press the AR/HR Key to specify the AR Area.

CQM1H-PRO01-E/CQM1-PRO01-E

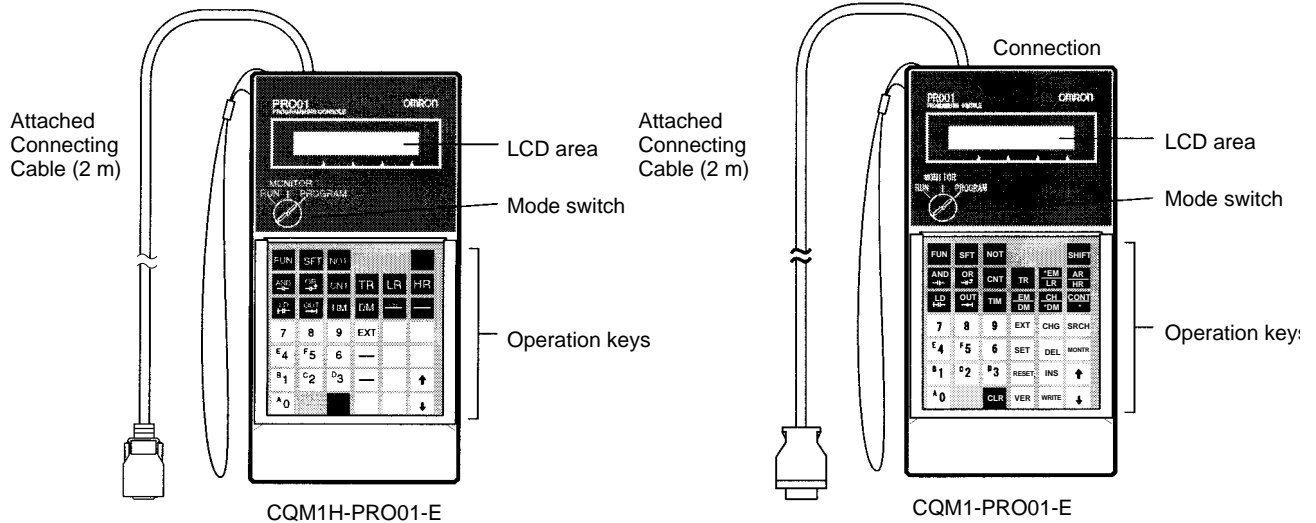

C200H-PRO27-E

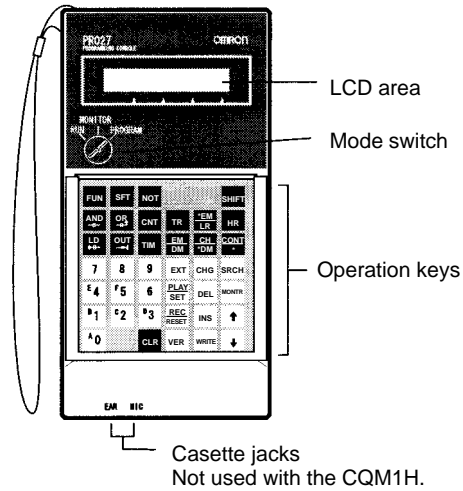

The following table shows the connecting cables that can be used to connect the C200H-PRO27-E to the CQM1H.

Model number	Connection	Length
C200H-CN222	Connect to the Peripheral port of a CS1W-CN114 Connecting Cable.	2 m
C200H-CN422		4 m
CS1W-CN224	Connect directly to the CQM1H's peripheral port.	2 m
CS1W-CN624		6 m

CQM1H-PRO01-E/CQM1-PRO01-E Key Sheet

FUN	SFT	NOT			SHIFT
AND ⊢⊣	OR ⊢⊣⊥	CNT	TR	*EM LR	AR HR
LD ⊢⊣	OUT ⊣⊥	TIM	EM DM	CH *DM	CONT *
7	8	9	EXT	CHG	SRCH
^E 4	^F 5	^D 6	SET	DEL	MONTR
^B 1	^C 2	^D 3	RESET	INS	⬆
^A 0		CLR	VER	WRITE	⬇

C200H-PRO27-E Key Sheet

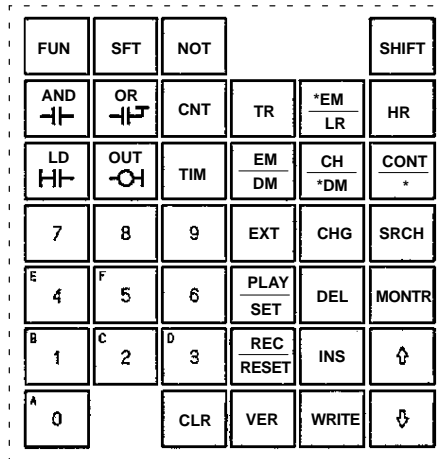

Use the SHIFT + HR Keys to specify the AR area.

Different Keys

The following keys are labeled differently on the CQM1H-PRO01-E, CQM1-PRO01-E and the C200H-PRO27-E, but the operation of the keys in each pair is identical.

CQM1-PRO01-E Keys	C200H-PRO27-E Keys
AR/HR	LR
AR/HR	HR
SET	PLAY/SET
RESET	REC/RESET

Note To specify the AR area, use SHIFT + HR Keys for the C200H-PRO27-E and use SHIFT + AR/HR Keys for the CQM1H-PRO01-E or CQM1-PRO01-E.

Using Programming Console Keys

Programming Console keys are used either individually or in combination with the SHIFT Key. The normal and SHIFT Key input of each key is written on the key.

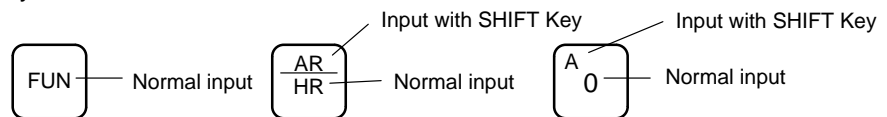

Normal Input

The normal input for the key is written in the middle or at the bottom of the key.

SHIFT Key Input

The input for the key after the SHIFT Key has been pressed is written at the top of the key or in the upper left corner of the key. It is not necessary to keep the SHIFT Key pressed down when pressing the next key.

A shift symbol will be displayed in the upper right corner of the display when the SHIFT Key is pressed. The shift input can be cleared by pressing the SHIFT Key again.



The operating mode can be changed without changing the display by pressing the SHIFT Key first.

Key Functions

The following table lists the basic uses of the Programming Console keys.

Key	Normal input	SHIFT Key input
	Function code	---
	SFT(10) instruction	---
	NC condition or differentiated instruction	---
	Shift mode	---
	AND instruction	---
	OR instruction	---
	COUNTER instruction (CNT) or counter address	---
	TR bits	---
	LR address	Indirect EM address
	HR address	AR address
Key	Normal input	SHIFT Key input
	LD instruction	---
	OUT instruction	---
	TIMER instruction (TIM) or timer address	---
	DM address	EM address
	Indirect DM address	IR/SR address
	Constant	Bit address

	Expansion function	---
	Data change	---
	Search operation	---
	Force-setting a bit	---
	Deletion	---
	Monitoring	---
	Force-resetting a bit	---
	Insertion	---
	Clearing the display or canceling an operation	---
	Verifications	---
	Writing	---
	Moving to previous memory, bit, or word address	Upward differentiation
	Moving to next memory, bit, or word address	Downward differentiation
	Inputting digits 0 to 9.	Inputting hexadecimal digits A to F.

Mode Switch

The mode switch controls the CQM1H's operating mode. The key can be removed when the switch is set to RUN or MONITOR but it cannot be removed when the switch is set to PROGRAM.

Contrast Control

The display contrast can be adjusted with the control on the right side of the Programming Console.

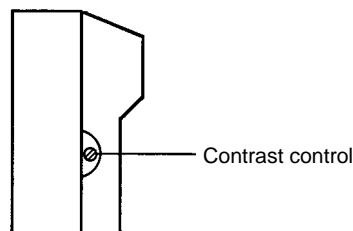
**Buzzer**

The C200H-PRO27-E's buzzer volume can be adjusted with the lever on the right side of the Programming Console. The CQM1H-PRO01-E or CQM1-PRO01-E's buzzer volume cannot be adjusted.

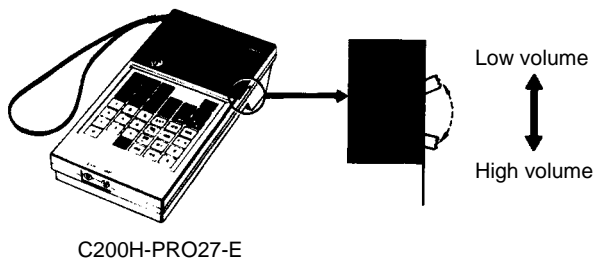

Note The buzzer can be turned ON and OFF with a key operation. See 7-3-4 *Buzzer Operation* for details.

7-2-2 Changing the CQM1H's Mode with the Mode Switch

Once the Programming Console has been connected, its mode switch can be used to change the CQM1H's operating mode. The mode display (<PROGRAM>, <MONITOR>, or <RUN>) will appear on the Programming Console screen.

- No key operations can be performed while the mode display is displayed on the Programming Console screen. Press CLR to clear the display so that key operations can be performed.
- If the SHIFT Key is pressed while the mode switch is turned, the original display will remain on the Programming Console's screen and the mode display won't appear.

- The CQM1H will enter RUN mode automatically if a Programming Console isn't connected when the CQM1H is turned ON.

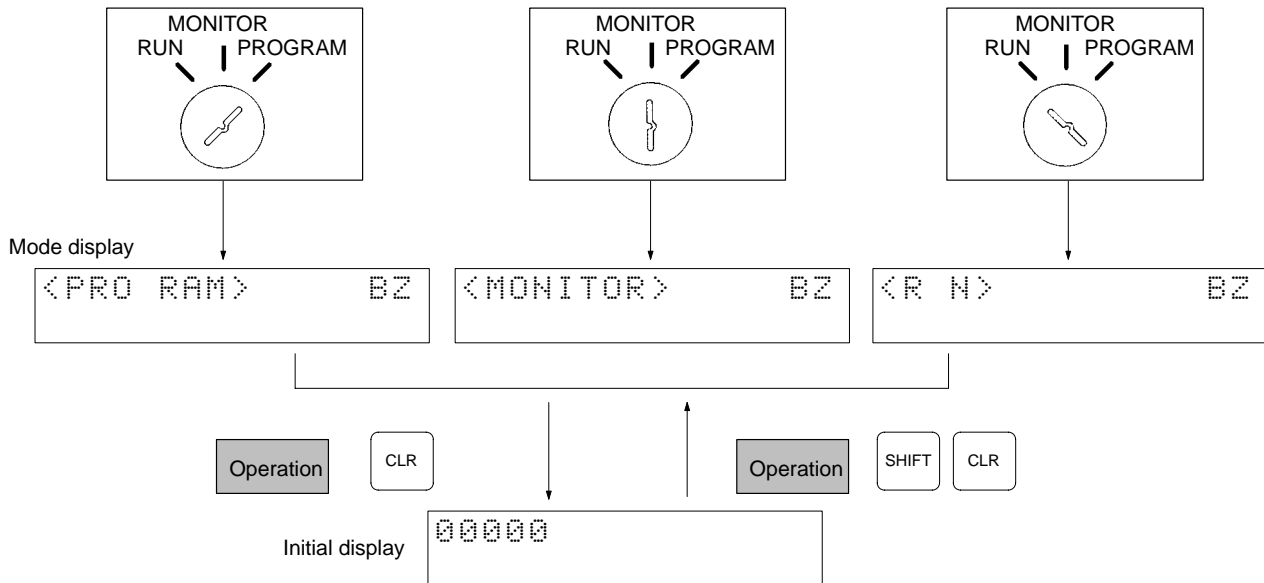

Operating Modes

PROGRAM Mode

The CQM1H program isn't executed in PROGRAM mode. Use PROGRAM mode to create and edit the program, clear memory, or check the program for errors.

MONITOR Mode

The CQM1H program is executed in MONITOR mode and I/O is processed just as it is in RUN mode. Use MONITOR mode to test system operations, such as monitoring CQM1H operating status, force-setting and resetting I/O bits, changing the SV/PV of timers and counters, changing word data, and online editing.

RUN Mode

This is the CQM1H's normal operating mode. The CQM1H's operating status can be monitored from a Programming Device, but bits can't be force-set/force-reset and the SV/PV of timers and counters can't be changed.

Caution Check the system thoroughly before changing the operating mode of the PC to prevent any accidents that might occur when the program is first started.

Caution Never change the mode while pressing any of the keys.

7-2-3 Operating Mode at Startup

The operating mode of the CQM1H when the power is turned ON depends upon the PC Setup settings and the Programming Console's mode switch setting if a Programming Console is connected.

PC Setup setting			Operating mode
Word	Bits	Setting	
DM 6600	08 to 15	00 Hex	Programming Console not connected: PROGRAM Programming Console connected: Mode set on the Programming Console's mode switch
		01 Hex	Startup mode is the same as the operating mode before power was interrupted.
		02 Hex	Startup mode is determined by bits 00 to 07.
	00 to 07	00 Hex	PROGRAM mode
		01 Hex	MONITOR mode
		02 Hex	RUN mode

Note If pin 7 on the DIP switch is ON, the above information may change depending on other settings in the PC Setup. Refer to *section 6-2 Communications Port and Startup Modes Settings* for details.

7-2-4 Preparation for Operation

This section describes the procedures required to begin Programming Console operation when using the Programming Console for the first time.

 **Caution** Always confirm that the Programming Console is in PROGRAM mode when turning ON the PC with a Programming Console connected unless another mode is desired for a specific purpose. If the Programming Console is in RUN mode when PC power is turned ON, any program in Program Memory will be executed, possibly causing a PC-controlled system to begin operation.

The following sequence of operations must be performed before beginning initial program input.

- 1, 2, 3... 1. Be sure that the PC is OFF.
2. On the DIP switch on the front of the CPU Unit, set pin 7 to OFF to enable a Programming Console Connection and make sure pin 3 is ON for English language displays.
3. Connect the Programming Console to the CPU Unit's Peripheral port. See *7-2 Connecting the Programming Console* for details.
(The CPU Unit's Communications Switch setting has no effect on communications with the Programming Console.)
4. Set the mode switch to PROGRAM mode.
5. Turn ON the PC.
6. Enter the password. See *7-2-5 Entering the Password* for details.
7. Clear (All Clear) the PC's memory. See *7-3-2 Clearing Memory* for details.
8. Read and clear all errors and messages. See *7-3-3 Reading/Clearing Error Messages* for details.
9. Start programming.

7-2-5 Entering the Password

To gain access to the PC's programming functions, you must first enter the password. The password prevents unauthorized access to the program.

The PC prompts you for a password when PC power is turned ON or, if PC power is already ON, after the Programming Console has been connected to the PC. To gain access to the system when the "Password!" message appears, press CLR and then MONTR. Then press CLR to clear the display.

If the Programming Console is connected to the PC when PC power is already ON, the first display below will indicate the mode the PC was in before the Programming Console was connected. **Ensure that the PC is in PROGRAM mode before you enter the password.** When the password is entered, the PC will shift to the mode set on the mode selector switch, causing PC operation to begin if the mode is set to RUN or MONITOR with the mode switch after entering the password.



Indicates the mode set by the mode selector switch.

7-3 Programming Console Operations

7-3-1 Overview

The following table lists the programming and monitoring operations that can be performed from a Programming Console. Refer to the rest of this section for details on operational procedures.

Name	Function	Page
Clearing memory	Clears all or part of the Program Memory and any data areas that are not read-only, as well as the contents of the Programming Console's memory.	152
Reading/clearing error messages	Displays and clears error messages and displays MESSAGE instruction messages.	154
Buzzer operation	Turns ON and OFF the buzzer that sounds when Programming Console keys are pressed.	154
Reading and assigning expansion instruction function codes	Reads or changes the function codes assigned to expansion instructions. (Pin 4 on the DIP switch must be ON to assign function codes to expansion instructions.)	155
Setting a program memory address	Sets the specified program memory address when reading, writing, inserting and deleting programs.	156
Reading a program memory address and monitoring bit status	Reads the contents of the Program Memory. Displays the status of the currently displayed bit in PROGRAM and MONITOR modes.	156
Entering or editing programs	Overwrites the contents of the current Program Memory to either input a program for the first time or to change a program that already exists.	156
Instruction search	Finds occurrences of the specified instruction in the program.	160
Bit operand search	Finds occurrences of the specified operand bit in the program.	160
Inserting and deleting instructions	Inserts or deletes instructions from the program.	161
Checking the program	Checks for programming errors and displays the program address and error when errors are found.	162
Bit, digit, word monitor	Monitors the status of up to 16 bits and words, although only 3 can be shown on the display at one time.	163
Multiple address monitor	Monitors the status of up to 6 bits and words simultaneously.	164
Binary monitor	Monitors the ON/OFF status of any word's 16 bits.	164
Three-word monitor	Monitors the status of three consecutive words.	165
Signed decimal monitor	Converts the contents of the specified word from signed hexadecimal (two's complement format) to signed decimal for display.	166

Name	Function	Page
Differentiation monitor	Monitors the up or down differentiation status of a particular bit.	167
Unsigned decimal monitor	Converts hexadecimal data in a word to unsigned decimal for display.	166
Changing timer, counter SV 1	Changes the SV of a timer or counter.	167
Changing timer, counter SV 2	Makes fine adjustment changes to the SV of the timer or counter.	168
Hexadecimal, BCD data modification	Changes the BCD or hexadecimal value of a word being monitored.	168
Binary data modification	Changes the status of a word's bits when the word is being monitored.	169
Signed decimal data modification	Changes the decimal value of a word being monitored as signed decimal data, within a range of -32,768 to 32,767 (-2,147,487,648 to 2,147,487,647 for double-length data). The contents of the specified word are converted automatically to signed hexadecimal (two's complement format.)	170
Unsigned decimal data modification	Changes the decimal value of a word being monitored as unsigned decimal data, within a range of 0 to 65,535 (0 to 4,294,967,295 for double-length data). A change into hexadecimal data is made automatically.	170
Three-word data modification	Changes the contents of one or more of the 3 consecutive words displayed in the Three-word Monitor operation.	171
Force set/reset	Forces bits ON (force set) or OFF (force reset.)	172
Clear force set/reset	Restores the status of all bits which have been force set of reset.	173
Hex-ASCII display change	Converts word data displays back and forth between 4-digit hexadecimal data and ASCII.	173
Reading and setting the clock	Reads or sets the internal clock. (A Memory Cassette with a clock must be mounted.)	174
Displaying the cycle time	Displays the current average cycle time (scan time.)	174

7-3-2 Clearing Memory

This operation is used to clear all or part of the Program Memory and data areas, as well as the contents of the Programming Console's memory. This operation is possible in PROGRAM mode only.

RUN	MONITOR	PROGRAM
No	No	OK

Before beginning to program for the first time or when installing a new program, clear all areas.

All Clear

The following procedure is used to clear memory completely, including the program, all data areas, counter PVs, Data Memory, and the PC Setup (DM 6600 to DM 6659).

- 1, 2, 3... 1. Bring up the initial display by pressing the CLR Key repeatedly.
2. Press the SET, NOT, and then the RESET Key to begin the operation.

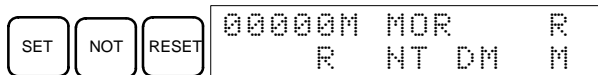

Note The EM area will be displayed for the CQM1H-CPU61 only.

3. Press the MONTR Key to clear memory completely.

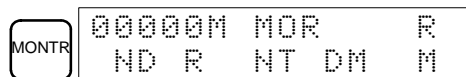

Caution

The PC Setup (DM 6600 through DM 6659) will be cleared when this operation is performed. The error log in DM 6569 to DM 6599 will not be cleared.

Partial Clear

It is possible to retain the data in specified areas or part of the Program Memory. To retain the data in the HR, TC, or DM Areas, press the appropriate key after

pressing SET, NOT, and RESET. Any data area that still appears on the display will be cleared when the MONTR Key is pressed.

The HR Key is used to specify both the AR and HR Areas, the CNT Key is used to specify the entire timer/counter area, and the DM Key is used to specify the DM Area, and the Shift and DM Keys are used to specify the EM Area (see next procedure).

It is also possible to retain a portion of the Program Memory from the first memory address to a specified address. After designating the data areas to be retained, specify the first Program Memory address to be cleared. For example, input 030 to leave addresses 000 to 029 untouched, but to clear addresses from 030 to the end of Program Memory.

As an example, follow the procedure below to retain the timer/counter area and Program Memory addresses 000 through 122. Refer to the next procedure in this section to change the specification for the EM Area.

- 1, 2, 3...
1. Press the CLR Key to bring up the initial display.
 2. Press the SET, NOT, and then the RESET Key to begin the operation.
 3. Press the CNT Key to remove the timer/counter area from the data areas shown on the display. (Counter PVs will not be cleared.)

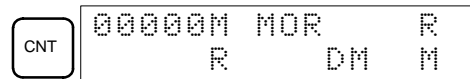

Note The EM area will be displayed for the CQM1H-CPU61 only.

4. Press 123 to specify 123 as the starting program address.

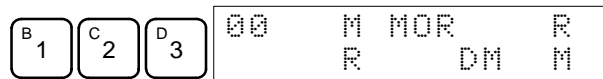

5. Press the MONTR Key to clear the specified regions of memory.

EM Area Specification

It is possible to retain or clear the data in the EM Area just as it is for the other areas, but the procedure is slightly different. The following procedure shows how to change the specification. This specification is used as part of the above procedure, *Partial Clear*.

The SHIFT and DM Keys are used to specify the EM Area.

Note The EM area will be displayed for the CQM1H-CPU61 only.

- 1, 2, 3...
1. Press the CLR Key to bring up the initial display.
 2. Press the SET, NOT, and then the RESET Key to begin the operation.

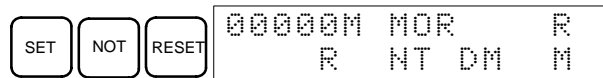

3. Press the SHIFT and EM/DM Keys to access the following display. The bank number will be displayed on the bottom line. If the clear operation is performed with the bank number displayed, the EM Area will be cleared.

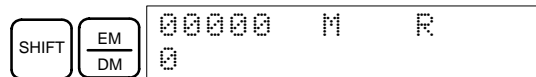

4. To clear the bank number so that the EM Area will not be cleared, press the 0 Key. The bank number will disappear.

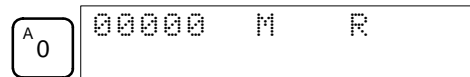

5. Press the SHIFT and EM/DM Keys to return to the previous memory clear display and complete the operation as described above in *Partial Clear*.

- Note**
1. The Up and Down Keys can be used to switch between the displays instead of the SHIFT and EM/DM Keys.
 2. EM will still be displayed on the Memory Clear Display even if the bank number has been deleted from the EM Clear Display. As long as the bank num-

ber has been deleted from the EM Clear Display, the EM Area will not be cleared.

3. The CQM1H-CPU61 CPU Unit has only one bank in the EM Area and only bank number 0 can be specified.

7-3-3 Reading/Clearing Error Messages

This operation is used to display and clear error messages. It is possible to display and clear non-fatal errors and MESSAGE instruction messages in any mode, but fatal errors can be cleared in PROGRAM mode only.

RUN	MONITOR	PROGRAM
OK	OK	OK

Before inputting a new program, any error messages recorded in memory should be cleared. It is assumed here that the causes of any of the errors for which error messages appear have already been taken care of. If the buzzer sounds when an attempt is made to clear an error message, eliminate the cause of the error, and then clear the error message. (Refer to *Section 5 Test Runs and Error Processing* for troubleshooting information.)

Key Sequence

Follow the procedure below to display and clear messages.

- 1, 2, 3... 1. Press the CLR Key to bring up the initial display.
2. Press the FUN and then the MONTR Key to begin the operation. If there are no messages, the following display will appear:

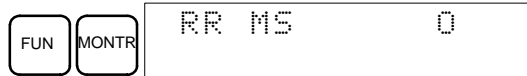

If there are messages, the most serious message will be displayed when the MONTR Key is pressed. Pressing MONTR again will clear the present message and display the next most serious error message. Continue pressing MONTR until all messages have been cleared. These are some examples of error messages:

A memory error:

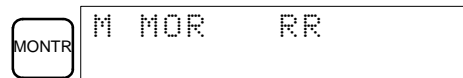

A system error:

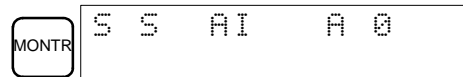

A message (displayed with MSG(46)):

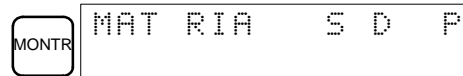

All messages cleared:

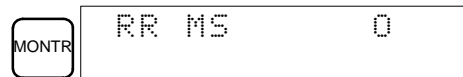

7-3-4 Buzzer Operation

This operation is used to turn ON and OFF the buzzer that sounds when Programming Console keys are pressed. This buzzer will also sound whenever an error occurs during PC operation. Buzzer operation for errors is not affected by this setting.

This operation is possible in any mode.

RUN	MONITOR	PROGRAM
OK	OK	OK

Key Sequence

Follow the procedure below to turn the key-input buzzer ON and OFF.

- 1, 2, 3... 1. Press the CLR, SHIFT, and then the CLR Key to bring up the mode display. In this case the PC is in PROGRAM mode and the buzzer is ON.



2. Press the SHIFT and then the 1 Key to turn OFF the buzzer. "BZ" will disappear from the display and the buzzer will not sound.

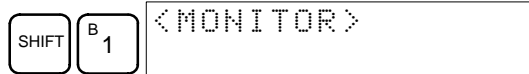

3. Press the SHIFT and then the 1 Key again to turn the buzzer back ON.

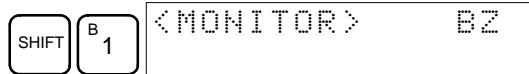

7-3-5 Reading and Assigning Expansion Instruction Function Codes

This operation is used to display or change the expansion instructions assigned to expansion instruction function codes. The assignments can be displayed in any mode, but can be changed in PROGRAM mode only.

Operation	RUN	MONITOR	PROGRAM
Read assignment	OK	OK	OK
Change assignment	No	No	OK

Turn ON pin 4 on the DIP switch and assign expansion instruction function codes before inputting the program. The CQM1H will not operate properly if expansion instructions aren't assigned correctly. An expansion instruction can be assigned to one function code only.



Caution

Pin 4 on the DIP switch must be ON to use user-assigned function codes for expansion instructions. If power is turned ON with pin 4 turned OFF, the expansion instructions will revert to their default function code settings and any user settings will be lost. Even if the function codes change, data will not be changed and the program will not execute as expected.

Refer to the *CQM1H Programming Manual* for the default function code assignments in the CQM1H.

- 1, 2, 3... 1. Press the CLR Key to bring up the initial display.
2. Press the EXT Key to display the assignment for the first function code (17).

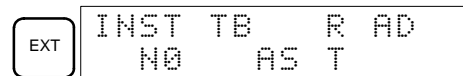

3. Press the Up and Down Arrow Keys to scroll through the expansion instruction function codes.

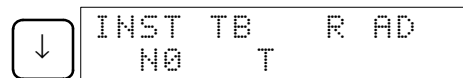

4. Press the CHG Key to assign a different expansion instruction to the selected function code.

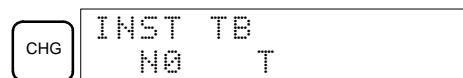

5. Press the Up and Down Arrow Keys to scroll through the expansion instructions that can be assigned to the selected function code.

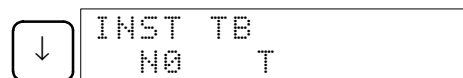

- Press the WRITE Key to assign the displayed instruction to the function code.

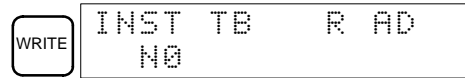

7-3-6 Setting and Reading a Program Memory Address and Monitoring Bit Status

This operation is used to display the specified program memory address and is possible in any mode. The ON/OFF status of any displayed bit will be shown if the PC is in RUN or MONITOR mode.

RUN	MONITOR	PROGRAM
OK	OK	OK

When inputting a program for the first time, it is generally written to Program Memory starting from address 000. Because this address appears when the display is cleared, it is not necessary to specify it.

When inputting a program starting from other than 000 or to read or modify a program that already exists in memory, the desired address must be designated.

- 1, 2, 3... 1. Press the CLR Key to bring up the initial display.
2. Input the desired address. It is not necessary to input leading zeroes.

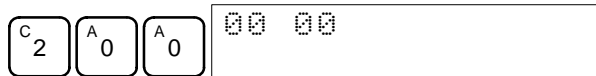

3. Press the Down Arrow Key. The ON/OFF status of any displayed bit will be shown in the upper right corner if the PC is in RUN or MONITOR mode.

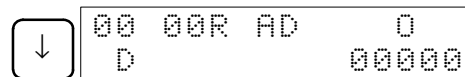

4. Press the Up and Down Arrow Keys to scroll through the program.

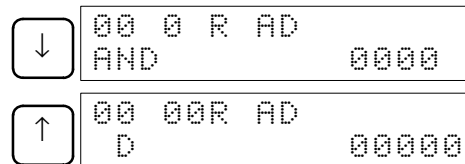

Note The MONTR Key can be pressed to switch to the Bit, Digit, Word Monitor Operation. When finished with the Bit, Digit, Word Monitor Operation, the CLR and Down Keys can be pressed to return to Setting and Reading a Program Memory Address and Monitoring Bit Status Operation.

7-3-7 Entering or Editing Programs

This operation is used enter or edit programs. It is possible in PROGRAM mode only.

RUN	MONITOR	PROGRAM
No	No	OK

The same procedure is used to either input a program for the first time or to change a program that already exists. In either case, the current contents of Program Memory is overwritten.

The program shown in the following diagram will be entered to demonstrate this operation.

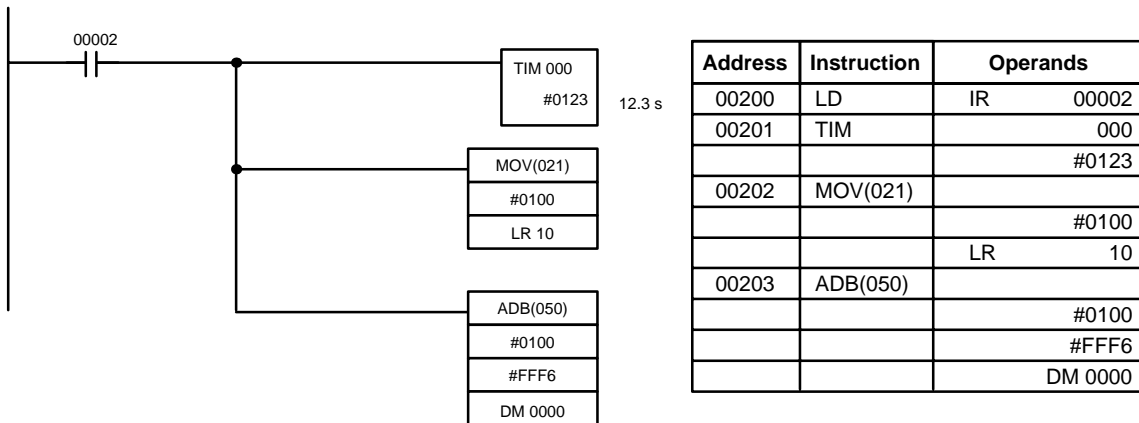

- 1, 2, 3... 1. Clear the display and set the address as follows:
- Press the CLR Key to bring up the initial display.
 - Specify the address where the program will begin.
 - Input the address where the program will begin and press the Down Arrow Key. It is not necessary to input leading zeroes.

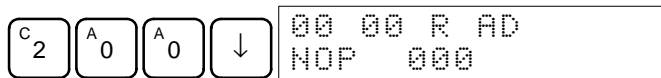

2. Write the first instruction to memory as follows:
- Input the first instruction and operand.

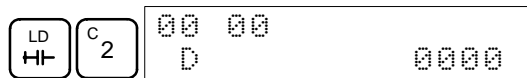

- Press the WRITE Key to write the instruction to Program Memory. The next program address will be displayed.

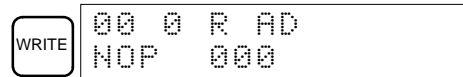

If a mistake was made inputting the instruction, press the Up Arrow Key to return to the previous program address and input the instruction again. The mistaken instruction will be overwritten

Timer and counter Completion Flags can be input as bit operands by inputting the instruction (e.g., LD, LD NOT, AND, etc.) and then pressing the TIM or CNT Key followed by the timer or counter number.

3. Input the timer instruction (TIM) as follows:
- Input the second instruction and operand. (In this case it isn't necessary to enter the timer number, because it's 000.) Press the WRITE Key to write the instruction to Program Memory.

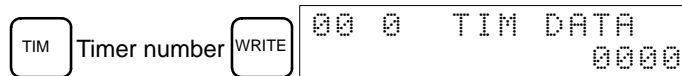

- Input the second operand (123 to specify 12.3 seconds) and press the WRITE Key. The next program address will be displayed.

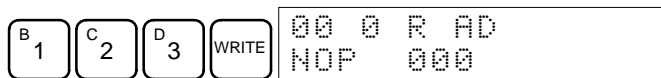

If a mistake was made inputting the operand, press the Up Arrow Key to return to display the mistaken operand and input the operand again.

Note a) Counters are input in the same basic way as timers except the CNT Key is pressed instead of the TIM Key.

b) Timer and counter SVs are input in BCD, so it isn't necessary to press the CONT/# Key.

4. Input the MOVE instruction (MOV(21)) as follows:

a) Input the third instruction and its operands. First input the instruction by pressing the FUN Key and then the function code (21 in this case).

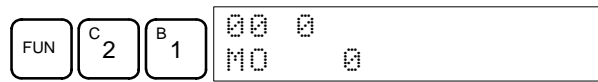

To input the differentiated version of an instruction, press the NOT Key after the function code (FUN 2 1 NOT). The "@" symbol will be displayed next to differentiated instructions. Press the NOT Key again to change back the instruction back to a non-differentiated instruction. The "@" symbol will disappear.

To change an instruction after it has been entered, simply scroll through the program until the desired instruction is displayed and press the NOT Key. The "@" symbol should be displayed next to the instruction.

b) Press the WRITE Key to write the instruction to Program Memory. The input display for the first operand will be displayed.

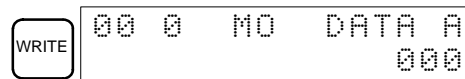

5. Input the first operand of MOV(21) as a constant as follows:

a) Input the constant, pressing the CONT/# Key first. The CONT/# Key is necessary to specify a constant because the default is for input of a memory address. The display will change to "#0000" when the CONT/# Key is pressed.

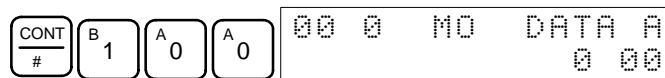

b) Press the WRITE Key to write the operand to Program Memory. The input display for the second operand will appear.

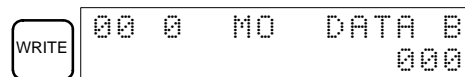

Note The operands of MOV(21) can be word addresses, so the CONT/# Key must be pressed to input a constant.

6. Input the second operand of MOV(21) as a word address as follows:

a) Input the operand, specifying the memory area first.

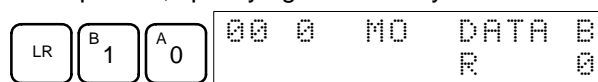

b) Press the WRITE Key to write the instruction to Program Memory. The next program address will be displayed.

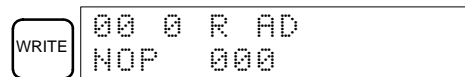

Note It isn't necessary to press the SHIFT + CH/# Keys when inputting an IR area bit or word address.

7. Input the ADB(50) instruction as follows:

a) Input the instruction using the function code.

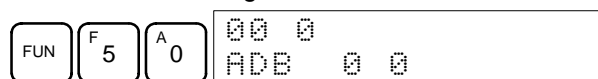

b) Press the WRITE Key to write the instruction to Program Memory.

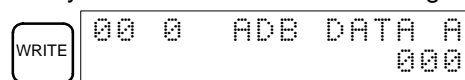

8. The first operand of ADB(50) as an unsigned (BCD) integer as follows:
- Specify input of an unsigned integer using the following keys. The CONT/# Key is required to specify input of a constant instead of a memory address.



- Input the value of the operand from 0 to 65535.

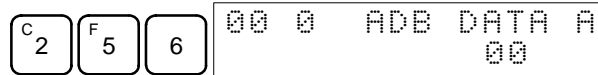

Note If an error is made, press the CLR Key to restore the status prior to the input. Then enter the correct input.

- Return to the hexadecimal display using the following keys.



Note If an input is made outside of the permissible range, a buzzer will sound and the hexadecimal display will not be displayed.

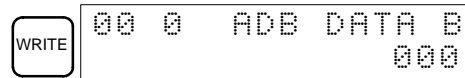

9. Input the second operand of ADB(5) as a signed (BCD) integer as follows:
- Specify input of a signed integer using the following keys. The CONT/# Key is required to specify input of a constant instead of a memory address.

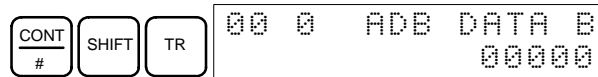

- Input the value of the operand from -32,768 to 32,767. Use the SET Key to input a positive number, and use the RESET Key to input a negative number.

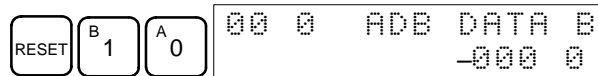

Note If an error is made, press the CLR Key to restore the status prior to the input. Then enter the correct input.

- Restore the hexadecimal display.

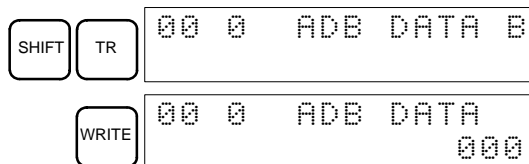

10. Input the third operand of ADB(5) as a word address as follows:
Input the final operand and then press the WRITE Key. (It isn't necessary to input leading zeroes.)

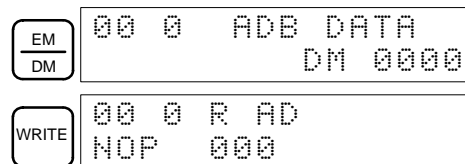

7-3-8 Instruction Search

This operation is used to find occurrences of the specified instruction in the program and is possible in any mode.

RUN	MONITOR	PROGRAM
OK	OK	OK

The ON/OFF status of any displayed bit will be shown if the PC is in RUN or MONITOR mode.

- 1, 2, 3...
1. Press the CLR Key to bring up the initial display.
 2. Input the address from which the search will begin and press the Down Arrow Key. It is not necessary to input leading zeroes.



3. Input the instruction to be found and press the SRCH Key. In this case, the search is for OUT 01000.

In this case, the next OUT 01000 instruction is at address 200, as shown below.



4. Press the Down Arrow Key to display the instruction's operands or press the SRCH Key to search for the next occurrence of the instruction.
5. The search will continue until an END instruction or the end of Program Memory is reached. In this case, an END instruction was reached at address 397. The total amount of memory used by the user program will also be displayed, and is 0.4 Kwords in this case.

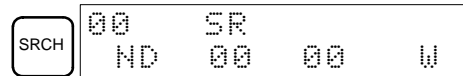

7-3-9 Bit Operand Search

This operation is used to find occurrences of the specified operand bit in the program and is possible in any mode.

RUN	MONITOR	PROGRAM
OK	OK	OK

The ON/OFF status of any displayed bit will be shown if the PC is in RUN or MONITOR mode.

- 1, 2, 3...
1. Press the CLR Key to bring up the initial display.
 2. Input the operand address. It is not necessary to input leading zeroes.

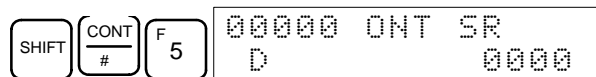

3. Press the SRCH Key to begin the search.

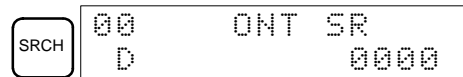

4. Press the SRCH Key to search for the next occurrence of the operand bit.

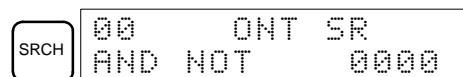

5. The search will continue until an END instruction or the end of Program Memory is reached. In this case, an END instruction was reached at ad-

dress 397. The total amount of memory used by the user program will also be displayed, and is 0.4 Kwords in this case.



7-3-10 Inserting and Deleting Instructions

This operation is used to insert or delete instructions from the program. It is possible in PROGRAM mode only.

RUN	MONITOR	PROGRAM
No	No	OK

To demonstrate this operation, an IR 00105 NO condition will be inserted at program address 00206 and an IR 00103 NO condition deleted from address 00205, as shown in the following diagram.

Original Program

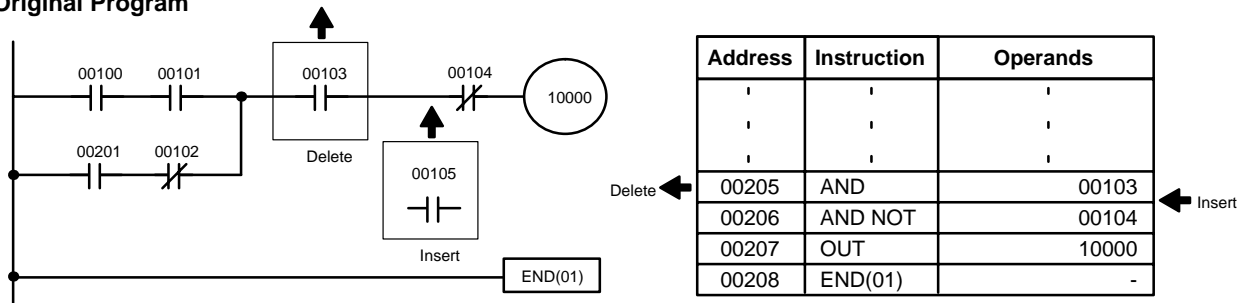

Insertion

Follow the procedure below to insert the IR 00105 NO condition at address 00206.

- 1, 2, 3... 1. Press the CLR Key to bring up the initial display.
2. Input the address where the NO condition will be inserted and press the Down Arrow Key. It is not necessary to input leading zeroes.

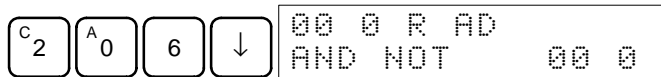

3. Input the new instruction and press the INS Key.



4. Press the Down Arrow Key to insert the new instruction.

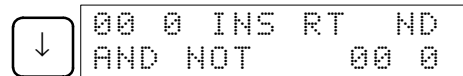

Note For instructions that require more operands (such as set values), input the operands and then press the WRITE Key.

Deletion

Follow the procedure below to delete the IR 00103 NO condition at address 00205.

- 1, 2, 3... 1. Press the CLR Key to bring up the initial display.
2. Input the address where the NO condition will be deleted and press the Down Arrow Key. It is not necessary to input leading zeroes.

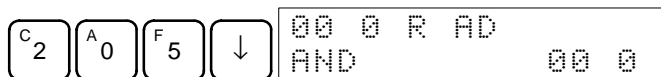

3. Press the DEL Key.

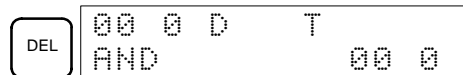

- Press the Up Arrow Key to delete the specified instruction.
If the instruction has more operands, the operands will be deleted automatically with the instruction.

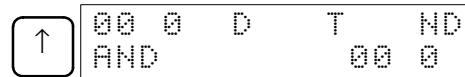

After completing the insertion and deletion procedures, use the Up and Down Arrow Keys to scroll through the program and verify that it has been changed correctly, as shown in the following diagram.

Corrected Program

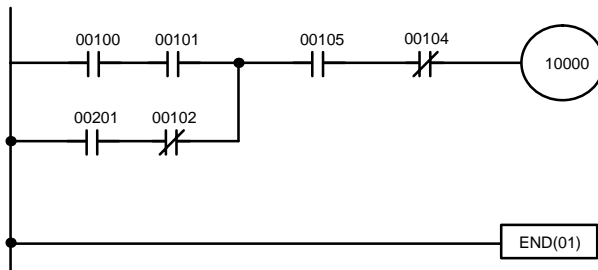

Address	Instruction	Operands
00205	AND	00105
00206	AND NOT	00104
00207	OUT	10000
00208	END(01)	-

7-3-11 Checking the Program

This operation checks for programming errors and displays the program address and error when errors are found. It is possible in PROGRAM mode only.

RUN	MONITOR	PROGRAM
No	No	OK

- 1, 2, 3... 1. Press the CLR Key to bring up the initial display.
2. Press the SRCH Key. An input prompt will appear requesting the desired check level.

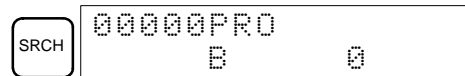

3. Input the desired check level (0, 1, or 2). The program check will begin when the check level is input, and the first error found will be displayed.

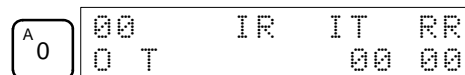

Note Refer to 7-4-5 *Checking the Program* for details on check levels and the errors that may be detected when the program is checked.

4. Press the SRCH Key to continue the search. The next error will be displayed. Continue pressing the SRCH Key to continue the search.
The search will continue until an END instruction or the end of Program Memory is reached. A display like this will appear if the end of Program Memory is reached:

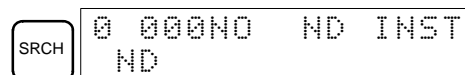

A display like this will appear if an END instruction is reached:



If errors are displayed, edit the program to correct the errors and check the program again. Continue checking the program by pressing SRCH Key until all errors have been corrected.

7-3-12 Bit, Digit, Word Monitor

This operation is used to monitor the status of up to 16 bits and words, although only 3 can be shown on the display at any one time. Operation is possible in any mode.

RUN	MONITOR	PROGRAM
OK	OK	OK

Note The PC's operating mode can be changed during the Bit, Digit, Word Monitor Operation without changing the display by pressing the SHIFT Key first and then changing the mode.

Program Read then Monitor

When a program address is being displayed, the status of the bit or word in that address can be monitored by pressing the MONTR Key.

- 1, 2, 3... 1. Press the CLR Key to bring up the initial display.
2. Input the desired program address and press the Down Arrow Key.

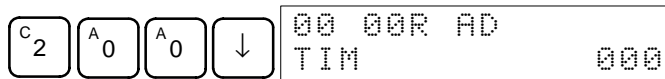

3. Press the MONTR Key to begin monitoring.



If the status of a bit is being monitored, that bit's status can be changed using the Force Set/Reset operation. Refer to 7-3-24 *Force Set, Reset* for details.

If the status of a word is being monitored, that word's value can be changed using the Hexadecimal/BCD Data Modification operation. Refer to 7-3-20 *Binary Data Modification* for details.

4. Press the CLR Key to end monitoring and return to bit status monitoring.

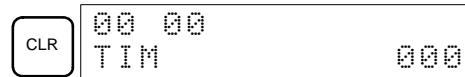

Bit Monitor

Follow the procedure below to monitor the status of a particular bit.

- 1, 2, 3... 1. Press the CLR Key to bring up the initial display.
2. Input the bit address of the desired bit and press the MONTR Key.

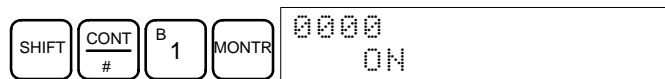

The Up or Down Arrow Key can be pressed to display the status of the previous or next bit.

The displayed bit's status can be changed using the Force Set/Reset operation. Refer to Refer to 7-3-24 *Force Set, Reset* for details.

3. Press the CLR Key to end monitoring.

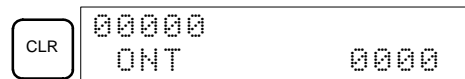

Word Monitor

Follow the procedure below to monitor the status of a particular word.

- 1, 2, 3... 1. Press the CLR Key to bring up the initial display.
2. Input the word address of the desired word.



3. Press the MONTR Key to begin monitoring.



The Up or Down Arrow Key can be pressed to display the status of the previous or next word.

The displayed word's status can be changed using the Hexadecimal/BCD Data Modification operation. Refer to Refer to 7-3-20 Binary Data Modification for details.

4. Press the CLR Key to end monitoring.

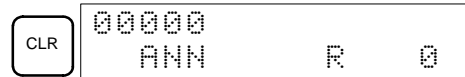

Note The PC's operating mode can be changed during the Bit, Digit, Word Monitor Operation without changing the display by pressing the SHIFT Key first and then changing the mode.

Multiple Address Monitoring

The status of up to six bits and words can be monitored simultaneously, although only three can be shown on the display at any one time.

1, 2, 3...

1. Press the CLR Key to bring up the initial display.
2. Input the address of the first bit or word and press the MONTR Key.

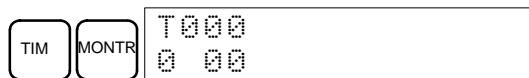

3. Repeat step 2 up to 6 times to display the next addresses to be monitored.



If 4 or more bits and words are being monitored, the bits and words that do not appear on the display can be displayed by pressing the MONTR Key. If the MONTR Key is pressed alone, the display will shift to the right.

If more than six bits and words are input, monitoring of the bit or word input first will be canceled.

4. Press the CLR Key to stop monitoring the leftmost bit or word and clear it from the display.

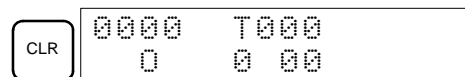

5. Press the SHIFT+CLR Keys to end monitoring altogether.

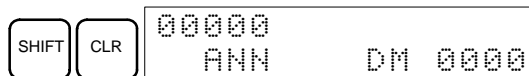

Note

1. The monitoring states can be retained for 6 bits and words.
2. The PC's operating mode can be changed during the Bit, Digit, Word Monitor Operation without changing the display by pressing the SHIFT Key first and then changing the mode.

7-3-13 Binary Monitor

This operation is used to monitor the ON/OFF status of any word's 16 bits. It is possible in any mode.

RUN	MONITOR	PROGRAM
OK	OK	OK

1, 2, 3...

1. Monitor the status of the desired word according to the procedure described in 7-3-12 Bit, Digit, Word Monitor. The desired word should be leftmost on the display if 2 or more words are being monitored.

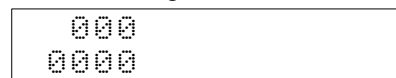

(Word monitor)

- Press the SHIFT and then the MONTR Key to begin binary monitoring. The ON/OFF status of the selected word's 16 bits will be shown along the bottom of the display. A 1 indicates a bit is ON, and a 0 indicates it is OFF.

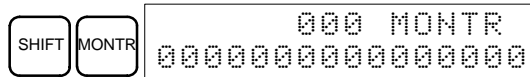

The status of force-set bits is indicated by "S," and the status of a force-reset bits is indicated by "R," as shown below.

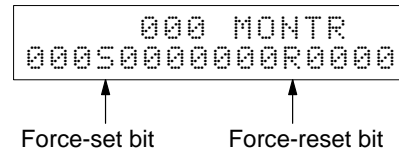

- Note**
- The status of displayed bits can be changed at this point. Refer to 7-3-20 Binary Data Modification for details.
 - The Up or Down Arrow Key can be pressed to display the status of the previous or next word's bits.

- Press the CLR Key to end binary monitoring and return to the normal monitoring display.

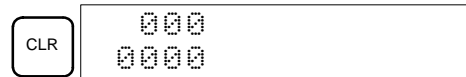

7-3-14 Three-word Monitor

This operation is used to monitor the status of three consecutive words. It is possible in any mode.

RUN	MONITOR	PROGRAM
OK	OK	OK

- 1, 2, 3... Monitor the status of the first of the three words according to the procedure described in 7-3-12 Bit, Digit, Word Monitor. If 2 or more words are being monitored, the desired first word should be left-most on the display.



(Word monitor)

- Press the EXT Key to begin three-word monitoring. The status of the selected word and the next two words will be displayed, as shown below. In this case, DM 0000 was selected.



The Up and Down Arrow Keys can be used to shift one address up or down. The status of the displayed words can be changed at this point. Refer to 7-3-23 Three-word Data Modification.

If ASCII characters are being displayed, three words of ASCII characters will be displayed. Refer to 7-3-26 Hex-ASCII Display Change for details.

- Press the CLR Key to end three-word monitoring and return to the normal monitoring display. The rightmost word on the three-word monitor display will be monitored.



7-3-15 Signed Decimal Monitor



This operation converts the contents of the word being monitored from signed hexadecimal (two's complement format) to signed decimal for display. The operation can be executed while using I/O monitoring, multiple address monitoring or three-word monitoring.

RUN	MONITOR	PROGRAM
OK	OK	OK

- 1, 2, 3... 1. Monitor the word that is to be used for decimal monitor with sign. During multiple address or three-word monitoring, the leftmost word will be converted.

(Multiple address monitor) 

2. Press the SHIFT+TR Keys to display the leftmost word as signed decimal.

3. Press the EXT Key to display double-word data. The following display would appear if DM 0201 contained FFFF.

At this point, the contents of the displayed word can be changed with a signed-decimal input. Refer to 7-3-21 Signed Decimal Data Modification.

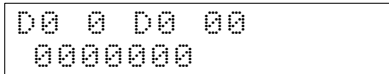
4. Press the CLR Key or the SHIFT+TR Keys to end the unsigned decimal display and return to normal monitoring. You will need to press the CLR Key twice if double-word monitoring has been used.

7-3-16 Unsigned Decimal Monitor





This operation is used to convert hexadecimal data in a word to unsigned decimal for display. The operation can be executed while using I/O monitoring, multiple address monitoring or three-word monitoring.

RUN	MONITOR	PROGRAM
OK	OK	OK

- 1, 2, 3... 1. Monitor the word that is to be used for decimal monitor without sign. During multiple address monitoring, the leftmost word will be converted.

Multiple address monitoring 

2. Press the SHIFT+TR+NOT Keys to display the leftmost word as unsigned decimal.

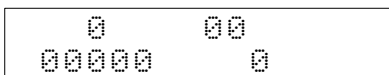

3. Press the EXT Key to display double-word data. The following display would appear if IR 201 contained 000.

At this point, the contents of the displayed word can be changed with an unsigned-decimal input. Refer to 7-3-22 Unsigned Decimal Data Modification.

- Press the CLR Key or the SHIFT+TR Keys to end the unsigned decimal display and return to normal monitoring. You will need to press the CLR Key twice if double-word monitoring has been used.

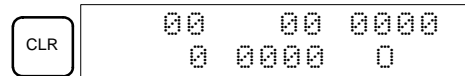

7-3-17 Differentiation Monitor

This operation is used to monitor the up or down differentiation status of a particular bit. When detected, the up or down differentiation will be displayed and the buzzer will sound. It is possible in any mode.

RUN	MONITOR	PROGRAM
OK	OK	OK

- 1, 2, 3... 1. Monitor the status of the desired bit according to the procedure described in 7-3-12 Bit, Digit, Word Monitor. If 2 or more bits are being monitored, the desired bit should be leftmost on the display.

In this case the differentiation status of LR 00 will be monitored.

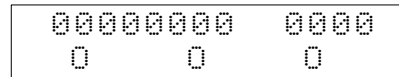

2. To specify up-differentiation monitoring, press the SHIFT and then the Up Arrow Key. The symbols "U@" will appear.



To specify down-differentiation monitoring, press the SHIFT and then the Down Arrow Key. The symbols "D@" will appear.

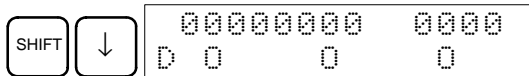

3. The buzzer will sound when the specified bit goes from OFF to ON (for up-differentiation) or from ON to OFF (for down-differentiation).

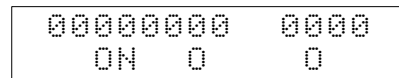

Note The buzzer will not sound if it has been turned OFF.

4. Press the CLR Key to end differentiation monitoring and return to the normal monitoring display.

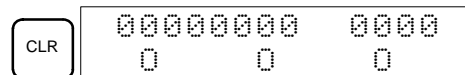

7-3-18 Changing Timer, Counter SV

There are two operations that can be used to change the SV of a timer or counter. They are possible in MONITOR or PROGRAM mode only. In MONITOR mode, the SV can be changed while the program is being executed.

RUN	MONITOR	PROGRAM
No	OK	OK

The timer or counter SV can be changed either by inputting a new value or by incrementing or decrementing the current SV.

Inputting a New SV Constant

This operation can be used to input a new SV constant, as well as to change an SV from a constant to a word address designation and vice versa. The following examples show how to input a new SV constant and how to change the SV from a constant to an address.

- 1, 2, 3... 1. Press the CLR Key to bring up the initial display.
2. Display the desired timer or counter.

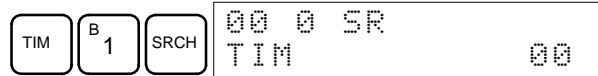

3. Press the Down Arrow Key and then the CHG Key.



4. At this point a new SV constant can be input or the SV constant can be changed to a word address designation

- a) To input a new SV constant, input the constant and press the WRITE Key.



- b) To change to a word address designation, input the word address and press the WRITE Key.



Incrementing and Decrementing a Constant

This operation can be used to increment and decrement an SV constant. It is possible only when the SV has been entered as a constant.

- 1, 2, 3... 1. Press the CLR Key to bring up the initial display.
2. Display the desired timer or counter.

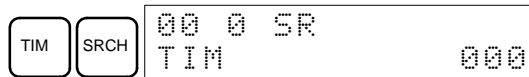

3. Press the Down Arrow, CHG, and then the EXT Key.

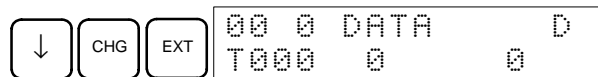

The constant on the left is the old SV and the constant on the right will become the new SV constant in step 5.

4. Press the Up and Down Arrow Keys to decrement and increment the constant on the right. (In this case the SV is decremented once.)

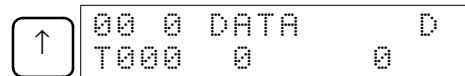

5. Press the CLR Key twice to change the timer's SV to the new value.

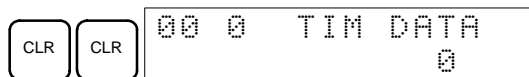

7-3-19 Hexadecimal, BCD Data Modification

This operation is used to change the contents of memory area words (including timer/counter present values). It is possible in MONITOR or PROGRAM mode only.

RUN	MONITOR	PROGRAM
No	OK	OK

Words SR 253 to SR 255 cannot be changed.



Caution Before changing the contents of I/O memory, be sure that the changes will not cause equipment to operate unexpectedly or dangerously. In particular, take care when changing the status of output bits. The PC continues to refresh I/O bits even if the PC is in PROGRAM mode, so devices connected to output points on Output Units may operate unexpectedly.

- 1, 2, 3... 1. Monitor the status of the desired word according to the procedure described in 7-3-12 Bit, Digit, Word Monitor. If two or more words are being monitored, the desired word should be leftmost on the display.

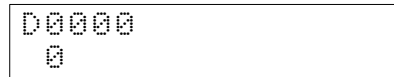

(Word monitor)

2. Press the CHG Key to begin hexadecimal, BCD data modification.



3. Input the new PV and press the WRITE Key to change the PV.

The operation will end and the normal monitoring display will return when the WRITE Key is pressed.

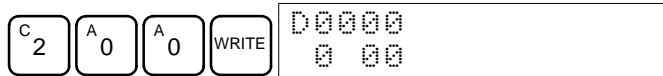

7-3-20 Binary Data Modification

This operation is used to change the contents of memory area words (including timer/counter present values) when the word is monitored using the procedure described in 7-3-13 Binary Monitor. It is possible in MONITOR or PROGRAM mode only.

RUN	MONITOR	PROGRAM
No	OK	OK

Bits SR 25300 to SR 25507 and timer/counter flags cannot be changed.

Caution Before changing the contents of I/O memory, be sure that the changes will not cause equipment to operate unexpectedly or dangerously. In particular, take care when changing the status of output bits. The PC continues to refresh I/O bits even if the PC is in PROGRAM mode, so devices connected to output points on the Output Units may operate unexpectedly.

- 1, 2, 3... 1. Monitor the status of the desired word according to the procedure described 7-3-13 Binary Monitor. Bit 00 is on the right and bit 15 is on the left.

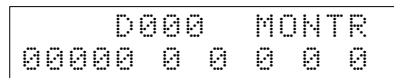

(Binary monitor)

2. Press the CHG Key to begin binary data modification.

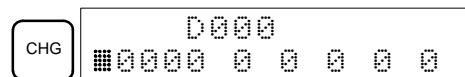

A flashing cursor will appear over bit 15. The cursor indicates which bit can be changed.

3. Three sets of keys are used to move the cursor and change bit status:
- Use the Up and Down Arrow Keys to move the cursor to the left or right.

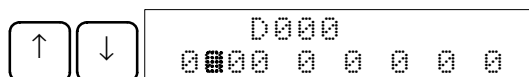

- Use the 1 and 0 Keys to change a bit's status to ON or OFF. The cursor will move one bit to the right after one of these keys is pressed.

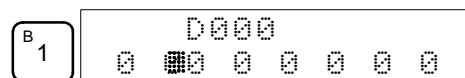

- c) Use the SHIFT+SET and SHIFT+RESET Keys to force-set or force-reset a bit's status. The cursor will move one bit to the right after one of these keys is pressed. The NOT Key will clear force-set or force-reset status.

Note Bits in the DM and EM Area cannot be force-set or force-reset.

- 4. Press the WRITE Key to write the changes in memory and return to the binary monitor.

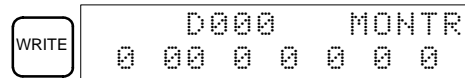

7-3-21 Signed Decimal Data Modification

This operation is used to change the decimal value of a data area word being monitored as signed decimal data, within a range of -32,768 to 32,767 (-2,147,483,648 to 2,147,483,647 for double-length data). The contents of the specified word are converted automatically to signed hexadecimal (two's complement format).

RUN	MONITOR	PROGRAM
No	OK	OK

Words SR 253 to SR 255 cannot be changed.

Caution Before changing the contents of I/O memory, be sure that the changes will not cause equipment to operate unexpectedly or dangerously. In particular, take care when changing the status of output bits. The PC continues to refresh I/O bits even if the PC is in PROGRAM mode, so devices connected to output points on the Output Units may operate unexpectedly.

- 1, 2, 3... 1. Monitor (signed decimal) the status of the word for which the present value is to be changed.

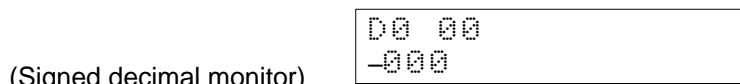

- 2. Press the CHG Key to begin decimal data modification.

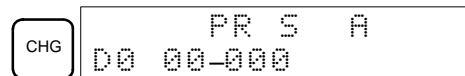

- 3. Input the new PV and press the WRITE Key to change the PV. The operation will end and the signed-decimal monitoring display will return when the WRITE Key is pressed.

The PV can be set within a range of -32,768 and 32,767 (-2,147,483,648 to 2,147,483,647 for double-length data). Use the SET Key to input a positive number, and use the RESET Key to input a negative number.



If an error is made, press the CLR Key to restore the status prior to the input. Then enter the correct input.

Note The buzzer will sound if the input value is not within range.

7-3-22 Unsigned Decimal Data Modification

This operation is used to change the decimal value of a data area word being monitored as unsigned decimal data, within a range of 0 to 65,535 (0 to

4,294,967,295 for double-length data). A change into hexadecimal data is made automatically.

Words SR 253 to SR 255 cannot be changed.

RUN	MONITOR	PROGRAM
No	OK	OK

Caution Before changing the contents of I/O memory, be sure that the changes will not cause equipment to operate unexpectedly or dangerously. In particular, take care when changing the status of output bits. The PC continues to refresh I/O bits even if the PC is in PROGRAM mode, so devices connected to output points on the Output Units may operate unexpectedly.

- 1, 2, 3... 1. Monitor (unsigned decimal) the status of the word for which the present value is to be changed.



2. Press the CHG Key to begin decimal data modification.

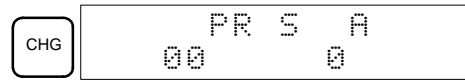

3. Input the new PV and press the WRITE Key to change the PV. The operation will end and the decimal-without-sign monitoring display will return when the WRITE Key is pressed.

The PV can be set within a range of 0 to 65,535 (0 to 4,294,967,295 for double-length data).



If an error is made, press the CLR Key to restore the status prior to the input. Then enter the correct input.

Note The buzzer will sound if the input value is not within range.

7-3-23 Three-word Data Modification

This operation is used to change the contents of one or more of the 3 consecutive words displayed in the Three-word Monitor operation. It is possible in MONITOR or PROGRAM mode only.

RUN	MONITOR	PROGRAM
No	OK	OK

Caution Before changing the contents of I/O memory, be sure that the changes will not cause equipment to operate unexpectedly or dangerously. In particular, take care when changing the status of output bits. The PC continues to refresh I/O bits even if the PC is in PROGRAM mode, so devices connected to output points on the Output Units may operate unexpectedly.

- 1, 2, 3... 1. Monitor the status of the desired words according to the procedure described in 7-3-14 Three-word Monitor.

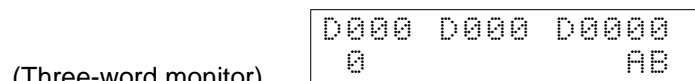

2. Press the CHG Key to begin three-word data modification. The cursor will appear next to the contents of the leftmost word.



3. Input the new value for the leftmost word on the display and press the CHG Key if more changes will be made.

(Input the new value and press the WRITE Key to write the changes in memory if no more changes will be made.)

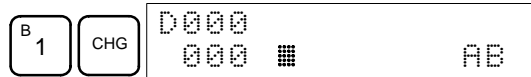

4. Input the new value for the middle word on the display and press the CHG Key if the rightmost word will be changed. Input the new value and press the WRITE Key to write the changes in memory if the rightmost word will not be changed. (In this case, it will not.)

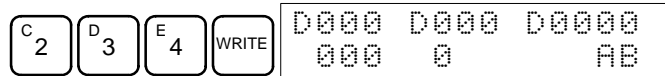

Note If the CLR Key is pressed before the WRITE Key, the operation will be cancelled and the three-word monitor display will return without any changes in data memory.

7-3-24 Force Set, Reset

This operation is used to force bits ON (force set) or OFF (force reset) and is useful when debugging the program or checking output wiring. It is possible in MONITOR or PROGRAM mode only.

RUN	MONITOR	PROGRAM
No	OK	OK

Caution Before changing the contents of I/O memory, be sure that the changes will not cause equipment to operate unexpectedly or dangerously. In particular, take care when changing the status of output bits. The PC continues to refresh I/O bits even if the PC is in PROGRAM mode, so devices connected to output points on the Output Units may operate unexpectedly.

- 1, 2, 3... 1. Monitor the status of the desired bit according to the procedure described in 7-3-12 Bit, Digit, Word Monitor. If two or more words are being monitored, the desired bit should be leftmost on the display.

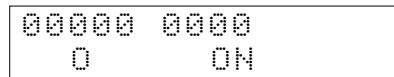

(Multiple address monitor)

2. Press the SET Key to force the bit ON or press the RESET Key to force the bit OFF.

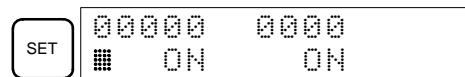

The cursor in the lower left corner of the display indicates that the force set/reset is in progress. Bit status will remain ON or OFF only as long as the key is held down; the original status will return one cycle after the key is released.

3. Press the SHIFT+SET or SHIFT+RESET Keys to maintain the status of the bit after the key is released. In this case, the force-set status is indicated by an "S" and the force-reset status is indicated by an "R."

To return the bit to its original status, press the NOT Key or perform the Clear Force Set/Reset operation. Refer to 7-3-25 Clear Force Set/Reset for details.

Forced status will also be cleared in the following cases:

- a) When the PC's operating mode is changed (although the forced status will not be cleared when the mode is changed between PROGRAM and MONITOR if SR 25211 is ON)

- b) When the PC stops because a fatal error occurred
- c) When the PC stops because of a power interruption

7-3-25 Clear Force Set/Reset

This operation is used to restore the status of all bits which have been force set or reset. It is possible in MONITOR or PROGRAM mode only.

RUN	MONITOR	PROGRAM
No	OK	OK

Caution Before changing the contents of I/O memory, be sure that the changes will not cause equipment to operate unexpectedly or dangerously. In particular, take care when changing the status of output bits. The PC continues to refresh I/O bits even if the PC is in PROGRAM mode, so devices connected to output points on the Output Units may operate unexpectedly.

- 1, 2, 3...**
1. Press the CLR Key to bring up the initial display.
 2. Press the SET and then the RESET Key. A confirmation message will appear.

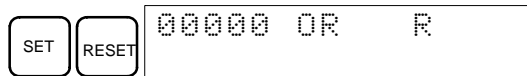

Note If you mistakenly press the wrong key, press CLR and start again from the beginning.

3. Press the NOT Key to clear the force-set/reset status of bits in all data areas.

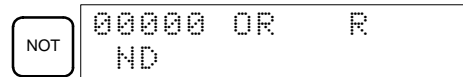

7-3-26 Hex-ASCII Display Change

This operation is used to convert word data displays back and forth between 4-digit hexadecimal data and ASCII. It is possible in any mode.

RUN	MONITOR	PROGRAM
OK	OK	OK

Note Displays of timer and counter present values cannot be changed.

- 1, 2, 3...**
1. Monitor the status of the desired word(s) according to the procedure described in 7-3-12 Bit, Digit, Word Monitor.

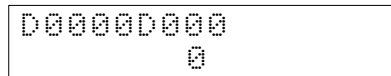

(Multiple address monitor)

2. Press the TR Key to switch to ASCII display. The display will toggle between hexadecimal and ASCII displays each time the TR Key is pressed.

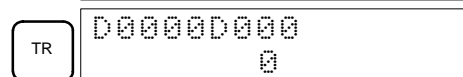
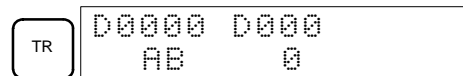

- Note**
1. If more than one word is being monitored under the Multiple Address Monitoring operation of the Bit, Digit, or Word Monitor Operation, only the contents of the word on the left will be changed.
 2. If more than one word is being monitored under the Three-word Monitor Operation, all three words will be changed.
 3. The present value can be changed during ASCII display, but the new value must be input as a 4-digit hexadecimal number.

7-3-27 Reading and Setting the Clock

This operation is used to read or set the CPU's clock in CQM1H CPU Units that are equipped with an internal clock. The clock can be read in any mode, but can be set in MONITOR or PROGRAM mode only.

Operation	RUN	MONITOR	PROGRAM
Read clock	OK	OK	OK
Set clock	No	OK	OK

- 1, 2, 3...
1. Press the CLR Key to bring up the initial display.
 2. Press the FUN Key, SHIFT Key, and then the MONTR Key to display the date and time.

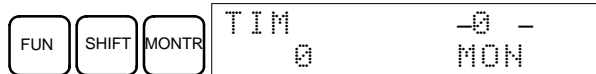

3. Press the CHG Key to change the date and/or time.



The digit that can be changed will flash. If necessary, input a new value with the Up and Down Arrow Keys or Numeric Keys. Press the CHG Key to move the cursor to the next digit. The following table shows the setting ranges for each value.

Year	Month	Day	Hour	Minute	Second	Day-of-week
00 to 99	01 to 12	01 to 31	00 to 23	00 to 59	00 to 59	0 to 6 (SUN to SAT)

4. Press the WRITE Key to write the new value.



Press the CLR Key to return to the initial display.

7-3-28 Displaying the Cycle Time

This operation is used to display the current average cycle time (scan time). It is possible only in RUN or MONITOR mode while the program is being executed.

RUN	MONITOR	PROGRAM
OK	OK	No

- 1, 2, 3...
1. Press the CLR Key to bring up the initial display.
 2. Press the MONTR Key to display the cycle time.

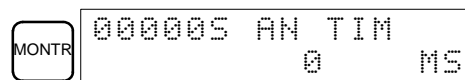

There might be differences in displayed values when the MONTR Key is pressed repeatedly. These differences are caused by changing execution conditions.

Note "MS" indicates milliseconds.

7-4 Programming Example

This section demonstrates all of the steps needed to write a program with the Programming Console.

7-4-1 Preparatory Operations

Use the following procedure when writing a program to the CQM1H for the first time.

- 1, 2, 3...
1. Set the Programming Console's mode switch to PROGRAM mode and turn ON the CQM1H's power supply. The password input display will appear on the Programming Console.

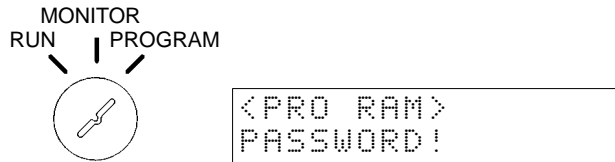

2. Enter the password by pressing the CLR and then the MONTR Key.

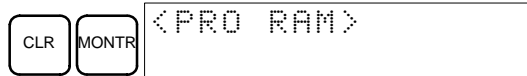

3. Clear the CQM1H's memory by pressing the CLR, SET, NOT, RESET, and then the MONTR Key. Press the CLR Key several times if memory errors are displayed.

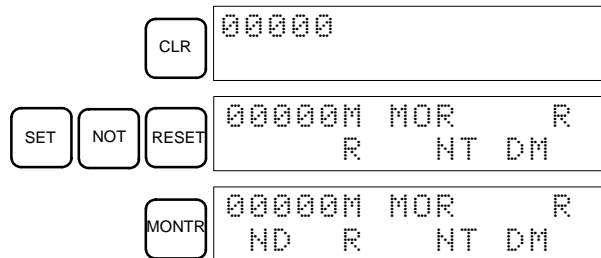

4. Display and clear error messages by pressing the CLR, FUN, and then the MONTR Key. Continue pressing the MONTR Key until all error messages have been cleared.

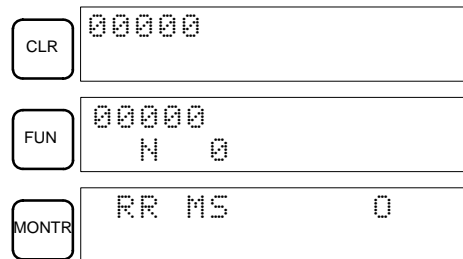

5. Press the CLR Key to bring up the initial programming display (program address 00000). The new program can be written at this point.

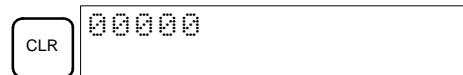

 **Caution** Check the system thoroughly before starting or stopping the CQM1H to prevent any accidents that might occur when the program is first started.

7-4-2 Programming Console Error Messages

Error messages will be displayed on the Programming Console whenever an error is made in operation. Refer to the following table for operation errors and corrections. Refer to the operation manual for messages from other Programming Devices.

Error message	Correction
CHK MEM (ROM)	Pin 1 of the CPU Unit's DIP switch is ON (write protect). Turn OFF pin 1 to enable writing.
PRGM OVER	The last program memory address is not NOP, making further program input impossible. Clear the program after the END(01) instruction.
ADR OVER	The set address exceeds the last address in the UM Area. Reset the address.
SET ERROR	FALS 00 has been input. "00" cannot be input. Reinput the instruction correctly.
I/O No. ERR	I/O data has been input outside the permissible range. Confirm the input ranges for the instructions and input the correct values.

7-4-3 Example Program

The following ladder program will be used to demonstrate how to write a program with the Programming Console. This program makes output IR 10000 flicker ON/OFF (one second ON, one second OFF) ten times after input IR 00000 is turned ON.

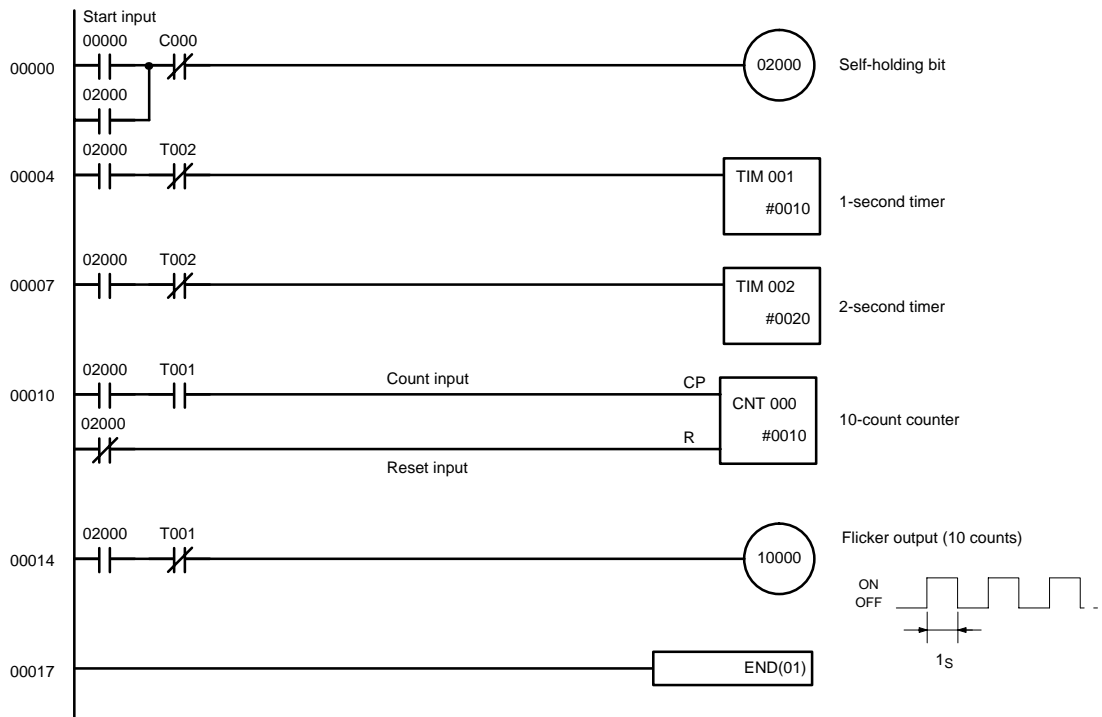

The mnemonic list for the example program is shown in the following table. The steps required to enter this program from a Programming Console are described in 7-4-4 Programming Procedures.

Address	Instruction	Data	Programming example procedures in 7-4-4 Programming Procedures
00000	LD	00000	(1) Self-holding bit
00001	OR	02000	
00002	AND NOT	C 000	
00003	OUT	02000	
00004	LD	02000	(2) 1-second timer
00005	AND NOT	T 002	
00006	TIM	001	
		# 0010	
00007	LD	02000	(3) 2-second timer
00008	AND NOT	T 002	
00009	TIM	002	
		# 0020	
00010	LD	02000	(4) 10-count counter
00011	AND	T 001	
00012	LD NOT	02000	
00013	CNT	000	
		# 0010	
00014	LD	02000	(5) Flicker output (10 counts)
00015	AND NOT	T 001	
00016	OUT	10000	
00017	END (01)	---	(6) END(01) instruction

7-4-4 Programming Procedures

The example program will be written to the CQM1H according to the mnemonic list in 7-4-3 Example Program. The procedure is performed beginning with the initial display. (Clear the memory before entering a new program.)

Note If an error occurs while inputting the program with the Programming Console, refer to the table on page 176. Refer to the relevant *Support Software Operation Manual* for details on errors that appear when operating the SSS or SYSMAC-CPT Support Software.

(1) Inputting the Self-holding Bit

- 1, 2, 3... 1. Input the normally open condition IR 00000.
(It isn't necessary to input leading zeroes.)

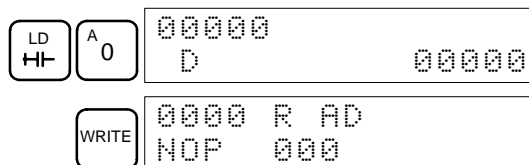

2. Input the OR condition IR 02000.

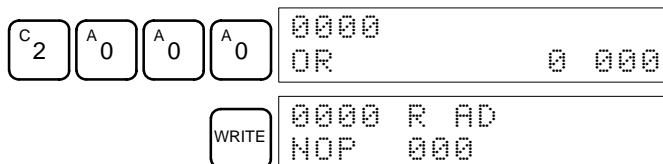

- Input the normally closed AND condition CNT 000.
(It isn't necessary to input leading zeroes.)

AND ┌─┴─┐	NOT	CNT	A 0	0000 AND NOT CNT 000
				WRITE 0000 R AD NOP 000

- Input the OUT instruction IR 02000.

NOT	C 2	A 0	A 0	A 0	0000 O T 0 000
					WRITE 0000 R AD NOP 000

(2) Inputting the One-second Timer

1, 2, 3...

- Input the normally open condition IR 20000.

LD ┌─┴─┐	C 2	A 0	A 0	A 0	0000 D 0 000
					WRITE 0000 R AD NOP 000

- Input the normally closed AND condition TIM 002.
(It isn't necessary to input leading zeroes.)

AND ┌─┴─┐	NOT	TIM	C 2	0000 AND NOT TIM 00
				WRITE 0000 R AD NOP 000

- Input the 1-second timer TIM 001.

TIM	B 1	0000 TIM 00
		WRITE 0000 TIM DATA 0000

- Input the SV for TIM 001 (#0010 = 1.0 s).

B 1	A 0	0000 TIM DATA 00 0
		WRITE 0000 R AD NOP 000

(3) Inputting the Two-second Timer

1, 2, 3...

The following key operations are used to input the 2-second timer.

- Input the normally open condition IR 20000.

LD ┌─┴─┐	C 2	A 0	A 0	A 0	0000 D 0 000
					WRITE 0000 R AD NOP 000

- Input the normally closed AND condition TIM 002.
(It isn't necessary to input leading zeroes.)

AND ┌─┴─┐	NOT	TIM	C 2	0000 AND NOT TIM 00
				WRITE 0000 R AD NOP 000

3. Input the 2-second timer TIM 002.

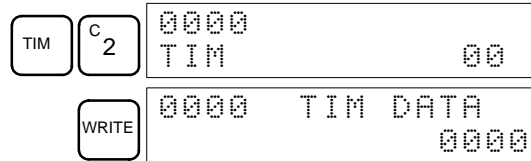

4. Input the SV for TIM 002 (#0020 = 2.0 s).

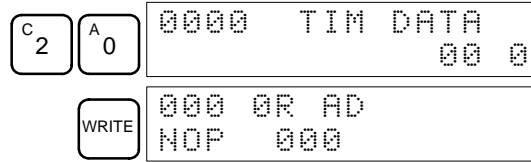

(4) Inputting the 10-count Counter

The following key operations are used to input the 10-count counter.

1, 2, 3...

1. Input the normally open condition IR 02000.

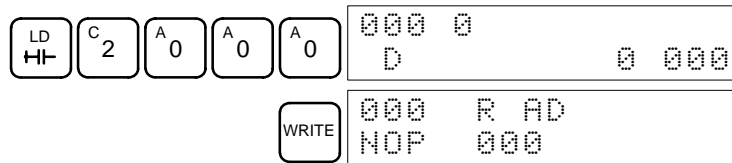

2. Input the normally open AND condition TIM 001.
(It isn't necessary to input leading zeroes.)

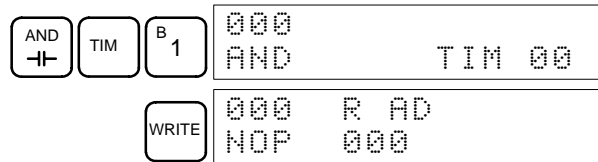

3. Input the normally closed condition IR 02000.

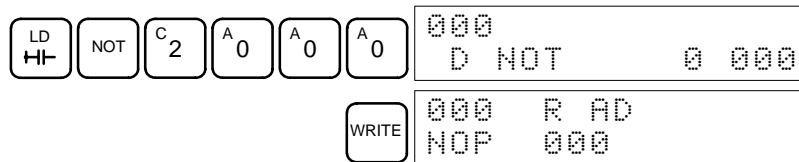

4. Input the counter 000.

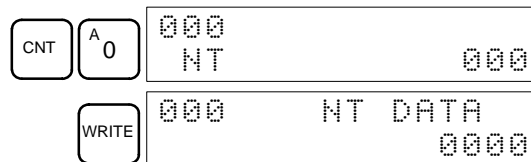

5. Input the SV for counter 000 (#0010 = 10 counts).

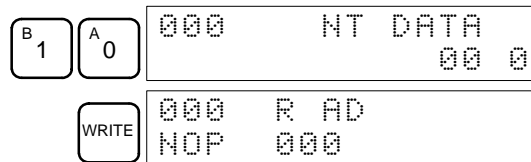

(5) Inputting the Flicker Output

1, 2, 3...

1. Input the normally open condition IR 02000.

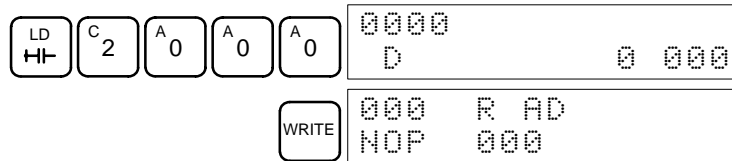

- Input the normally closed AND condition TIM 001.
(It isn't necessary to input leading zeroes.)

AND ⊖	NOT	TIM	B 1	000 AND NOT TIM 00
WRITE				000 R AD NOP 000

- Input the OUT instruction IR 01000.
(It isn't necessary to input leading zeroes.)

NOT	B 1	A 0	A 0	A 0	000 O T 0 000
WRITE					000 R AD NOP 000

(6) Inputting the END(001) Instruction

Input END(01). (The display shows three digits in the function code, but only the last two digits are input for CQM1H PCs.)

FUN	000 N 0	
A 0	B 1	000 ND 00
WRITE		000 R AD NOP 000

7-4-5 Checking the Program

Check the program syntax in PROGRAM mode to make sure that the program has been input correctly.

- 1, 2, 3... 1. Press the CLR Key to bring up the initial display.

CLR	00000
-----	-------

2. Press the SRCH Key. An input prompt will appear requesting the desired check level.

SRCH	00000PRO B 0-
------	------------------

3. Input the desired check level (0, 1, or 2). The program check will begin when the check level is input, and the first error found will be displayed. If no errors are found, the following display will appear.

A 0	000 PRO ND 00 00 W
-----	-----------------------

Check levels are specified as follows:

- | |
|-----|
| A 0 |
|-----|

 : Levels A, B, and C are checked.
- | |
|-----|
| B 1 |
|-----|

 : Levels A and B are checked.
- | |
|-----|
| C 2 |
|-----|

 : Level A is checked.

Note A list of programming errors is provided at the end of this section.

4. Press the SRCH Key to continue the search. The next error will be displayed. Continue pressing the SRCH Key to continue the search.

The search will continue until an END(01) instruction or the end of Program Memory is reached.

If errors are displayed, edit the program to correct the errors and check the program again. Continue checking the program until all errors have been corrected. Three levels of program checking are available. The desired level must be designated to indicate the type of errors that are to be detected. The following table provides the error types, displays, and explanations of all syntax errors. Check level 0 checks for type A, B, and C errors; check level 1, for type A and B errors; and check level 2, for type A errors only.

Type	Message	Meaning and appropriate response
A	?????	The program has been damaged, creating a non-existent function code. Re-enter the program.
	CIRCUIT ERR	The number of LD instructions (LD or LD NOT) does not match the number of logic block instructions (OR LD or AND LD). Check your program.
	OPERAND ERR	A constant entered for the instruction is not within defined values. Change the constant so that it lies within the proper range.
	NO END INSTR	There is no END(01) in the program. Write END(01) at the end of the program.
	LOCN ERR	An instruction is in the wrong place in the program. Check instruction requirements and correct the program.
	JME UNDEFD	A JME(04) instruction is missing for a JMP(05) instruction. Correct the jump number or insert the proper JME(04) instruction.
	DUPL	The same jump number or subroutine number has been used twice. Correct the program so that the same number is used only once for each.
	SBN UNDEFD	An SBN(92) has not been programmed with the same subroutine number as an SBS(91) instruction in the program. Correct the program.
STEP ERR	STEP(08) with a section number and STEP(08) without a section number have been used incorrectly. Check STEP(08) programming requirements and correct the program.	
B	IL-ILC ERR	IL(02) and ILC(03) are not used in pairs. Correct the program so that each IL(02) has a unique ILC(03). Although this error message will appear if more than one IL(02) is used with the same ILC(03), the program will executed as written. Make sure your program is written as desired before proceeding.
	JMP-JME ERR	JMP(04) and JME(05) are not used in pairs. Make sure your program is written as desired before proceeding.
	SBN-RET ERR	RET(93) has not been used properly or the relationship between SBN(92) and RET(93) is not correct. Correct the program.

Type	Message	Meaning and appropriate response
C	COIL DUPL	The same bit is being controlled (i.e., turned ON and/or OFF) by more than one instruction (e.g., OUT, OUT NOT, DIFU(13), DIFD(14), KEEP(11), SFT(10)). or the same timer or counter number has been used more than once. Although controlling bit status from more than one instruction is allowed for certain instructions, check instruction requirements to confirm that the program is correct or rewrite the program so that each bit is controlled by only one instruction.
	JMP UNDEFD	JME(05) has been used with no JMP(04) with the same jump number. Add a JMP(04) with the same number or delete the JME(05) that is not being used.
	SBS UNDEFD	A subroutine exists that is not called by SBS(91). Program a subroutine call in the proper place, or delete the subroutine if it is not required.

7-4-6 Test Run in MONITOR Mode

Switch the CQM1H in MONITOR mode and check the operation of the program.

- 1, 2, 3... 1. Set the Programming Console's mode switch to MONITOR mode.



```
<MONITOR>      BZ
```

2. Press the CLR Key to bring up the initial display.

```
CLR  00000
```

3. Force-set the start input bit (IR 00000) from the Programming Console to start the program.

```
LD  00000
HI  D          00000

MONTR 00000
      0

SET  00000
     ■ ON
```

The cursor in the lower left corner of the display indicates that the force set is in progress. The bit will remain ON as long as the Set Key is held down.

4. The output indicator for output IR 01000 will flash ten times if the program is operating correctly. The indicator should go OFF after ten one-second flashes.

There is a mistake in the program if the output indicator doesn't flash. In this case, check the program and force set/reset bits to check operation.

SECTION 8

Inner Boards

This section describes hardware information for the following Inner Boards: Serial Communications Board, High-speed Counter Board, Pulse I/O Board, Absolute Encoder Interface Board, Analog Setting Board, and Analog I/O Board. Refer to the *CQMIH Programming Manual* for information on software application.

8-1	High-speed Counter Board
8-1-1	Model
8-1-2	Functions
8-1-3	Example System Configuration
8-1-4	Applicable Inner Board Slots
8-1-5	Names and Functions
8-1-6	Pin Arrangement of Connectors CN1 and CN2
8-1-7	Wiring Examples
8-1-8	Specifications
8-1-9	Internal Circuits
8-2	Pulse I/O Board
8-2-1	Model
8-2-2	Function
8-2-3	System Configuration
8-2-4	Applicable Inner Board Slot
8-2-5	Names and Functions
8-2-6	CN1 and CN2 Pin Arrangement
8-2-7	Wiring Examples
8-2-8	Specifications
8-3	Absolute Encoder Interface Board
8-3-1	Model
8-3-2	Functions
8-3-3	System Configuration
8-3-4	Applicable Inner Board Slots
8-3-5	Names and Functions
8-3-6	Pin Arrangement of Connectors CN1 and CN2
8-3-7	Wiring Examples
8-3-8	Specifications
8-3-9	Internal Circuit Configuration
8-4	Analog Setting Board
8-4-1	Model
8-4-2	Function
8-4-3	Applicable Inner Board Slots
8-4-4	Names and Functions
8-4-5	Specifications
8-5	Analog I/O Board
8-5-1	Model
8-5-2	Function
8-5-3	System Configuration
8-5-4	Applicable Inner Board Slot
8-5-5	Names and Functions
8-5-6	Pin Arrangement of Connectors CN1 and CN2
8-5-7	Wiring Examples
8-5-8	Specifications
8-5-9	Internal Circuit Configuration
8-6	Serial Communications Board
8-6-1	Model Number
8-6-2	Serial Communications Boards
8-6-3	Features
8-6-4	System Configuration

8-1 High-speed Counter Board

8-1-1 Model

Name	Model	Specification
High-speed Counter Board	CQM1H-CTB41	Four pulse inputs Four external outputs of comparison result

8-1-2 Functions

The High-speed Counter Board is an Inner Board that handles four pulse inputs.

High-speed Counter Pulse Inputs 1 to 4

The High-speed Counter Board counts high-speed pulses from 50 to 500 kHz entering through ports 1 to 4, and performs tasks according to the number of pulses counted.

Input Modes

The following three Input Modes are available:

- Differential Phase Mode (1x/2x/4x)
- Up/Down Mode
- Pulse/Direction Mode

Comparison Operation

When the PV (present value) of the high-speed counter matches a specified target value or lies within a specified range, the bit pattern specified in the comparison table is stored in internal output bits and external output bits. A bit pattern can be set for each comparison result, and the external output bits can be output through an external output terminal as described below.

External Outputs

Up to four external outputs can be produced when either the target value is matched or a range comparison condition is satisfied.

Note The High-speed Counter Board does not provide high-speed counter interrupts. It simply compares the PV to target values or comparison ranges, and produces internal and external bit outputs.

8-1-3 Example System Configuration

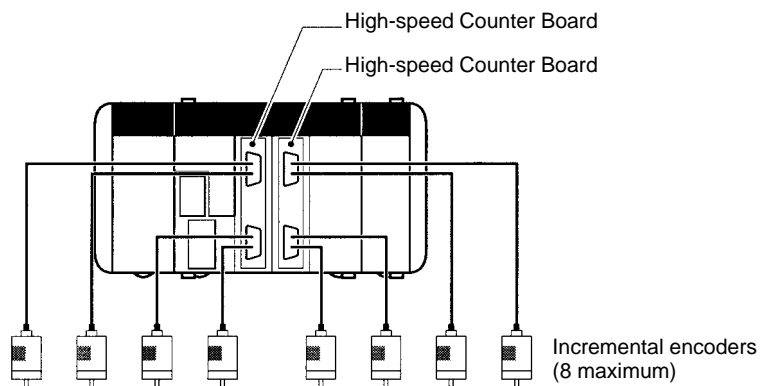

8-1-4 Applicable Inner Board Slots

The High-speed Counter Board can be installed in either slot 1 (left slot) or slot 2 (right slot) of the CQM1H-CPU51/61 CPU Unit. Both slots can be used at the same time.

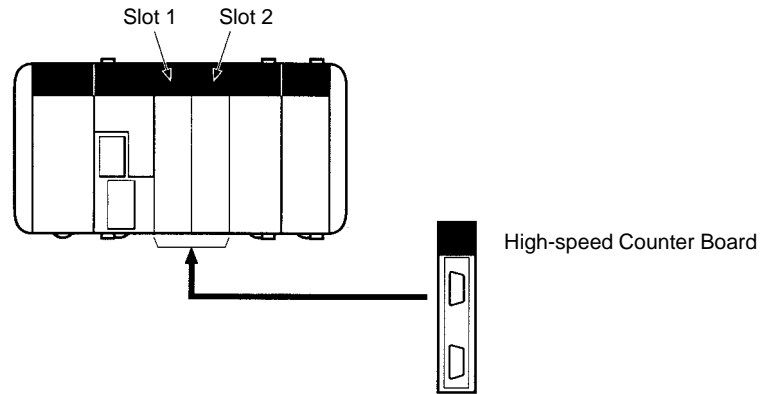

8-1-5 Names and Functions

One High-speed Counter Board provides two connectors that accept high-speed pulse inputs. CN1 is used for inputs 1 and 2, and CN2 is used for inputs 3 and 4.

CQM1H-CTB41 High-speed Counter Board

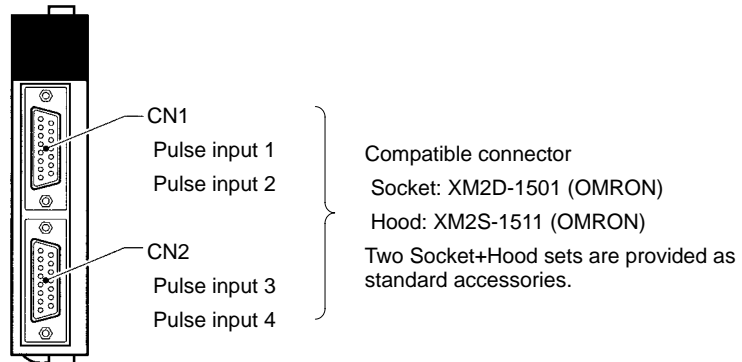

LED Indicators

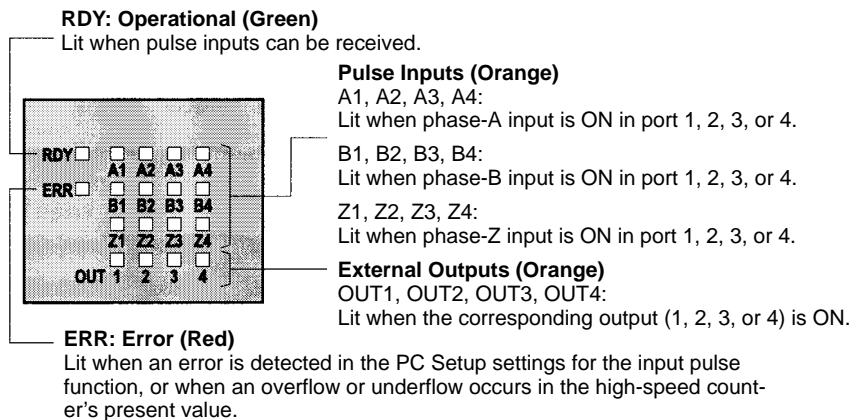

Input Voltage Level Switches

Counter 1	Counter 2	Counter 3	Counter 4	Status	Setting	
SW6-1	SW6-2	SW3-1	SW3-2	ON	Counter input: Input voltage A	Line driver level
				OFF		24-V DC level (default)
SW5-1	SW5-2	SW2-1	SW2-2	ON	Counter input: Input voltage B	Line driver level
				OFF		24-V DC level (default)
SW4-1	SW4-2	SW1-1	SW1-2	ON	Counter input: Input voltage Z	Line driver level
				OFF		24-V DC level (default)

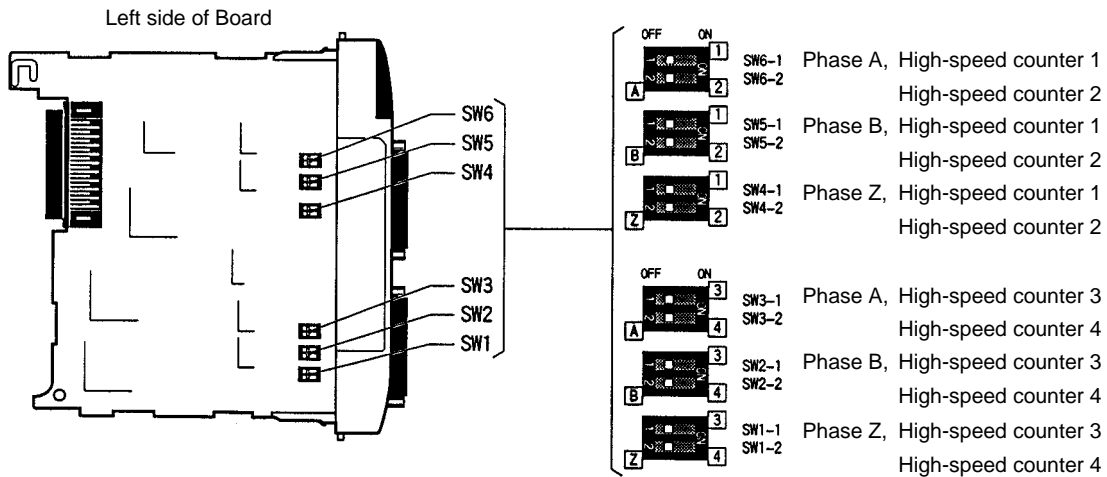

8-1-6 Pin Arrangement of Connectors CN1 and CN2

CN1: Pulse Input 1 and 2

Pin arrangement	Pin No.	Name	Function
	1	2OUT	External output 2
	2	1OUT	External output 1
	3	1Z-	Counter 1 input: Z -
	4	1Z+	Counter 1 input: Z +
	5	1B-	Counter 1 input: B -
	6	1B+	Counter 1 input: B +
	7	1A-	Counter 1 input: A -
	8	1A+	Counter 1 input: A +
	9	+DC	Power supply for external outputs 1 to 4: 5 to 24 V DC
	10	2Z-	Counter 2 input: Z -
	11	2Z+	Counter 2 input: Z +
	12	2B-	Counter 2 input: B -
	13	2B+	Counter 2 input: B +
	14	2A-	Counter 2 input: A -
	15	2A+	Counter 2 input: A +
Hood	NC	Not used.	

CN2: Pulse Input 3 and 4

Pin arrangement	Pin No.	Name	Function
	1	3Z-	Counter 3 input: Z -
	2	3Z+	Counter 3 input: Z +
	3	3B-	Counter 3 input: B -
	4	3B+	Counter 3 input: B +
	5	3A-	Counter 3 input: A -
	6	3A+	Counter 3 input: A +
	7	4OUT	External output 4
	8	3OUT	External output 3
	9	4Z-	Counter 4 input: Z -
	10	4Z+	Counter 4 input: Z +
	11	4B-	Counter 4 input: B -
	12	4B+	Counter 4 input: B +
	13	4A-	Counter 4 input: A -
	14	4A+	Counter 4 input: A +
	15	-DC	Power supply for external outputs 1 to 4: 0 V
Hood	NC	Not used.	

Note Refer to *Appendix A Preparing Cables for Inner Boards* for information about using a compatible connector (XM2D-1501 Socket with XM2S-1511 Hood) to construct a cable.

8-1-7 Wiring Examples

Pulse Input Connections Connect the encoder outputs to CN1 and CN2 as shown below according to the port's Input Mode.

CN1 pins		CN2 pins		Signal name	Encoder output		
Port 1	Port 2	Port 3	Port 4		Differential Phase Mode	Pulse/Direction Mode	Up/Down Mode
8 (7)	15 (14)	6 (5)	14 (13)	Encoder input A	Encoder phase A input	Pulse input	Increment pulse input
6 (5)	13 (12)	4 (3)	12 (11)	Encoder input B	Encoder phase B input	Directional signal input	Decrement pulse input

Note Pin numbers for negative pins are given in parentheses.

Differential Phase Mode

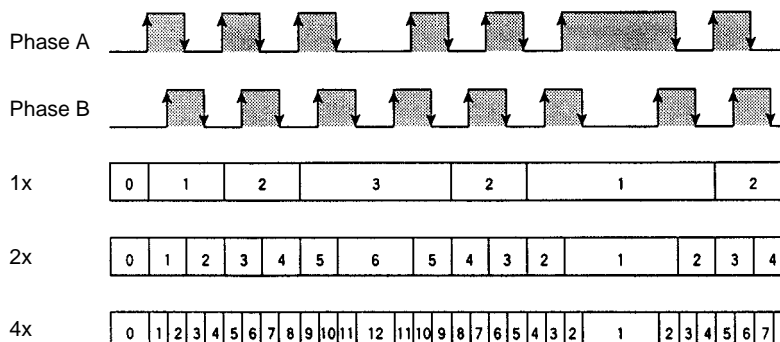

Phase A	Phase B	1x	2x	4x
↑	L	Count up	Count up	Count up
H	↑	---	---	Count up
↓	H	---	Count up	Count up
L	↓	---	---	Count up
L	↑	---	---	Count down
↑	H	---	Count down	Count down
H	↓	---	---	Count down
↓	L	Count down	Count down	Count down

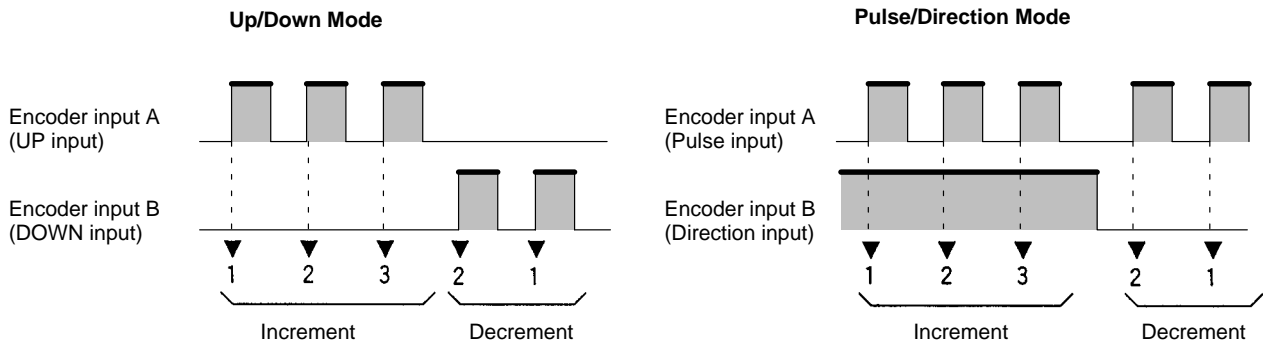

Note The function of encoder inputs A and B in Pulse/Direction Mode and Up/Down Mode differs from the Pulse I/O Board (CQM1H-PLB21).

Wiring Examples

The following diagrams show a connection to an encoder possessing phases A, B, and Z.

Connecting to 24-V DC Open-collector Encoder

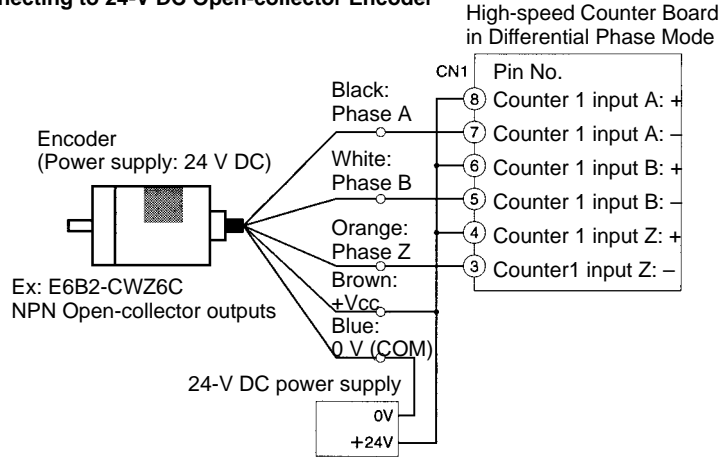

(Do not share the power supply with other I/O.)

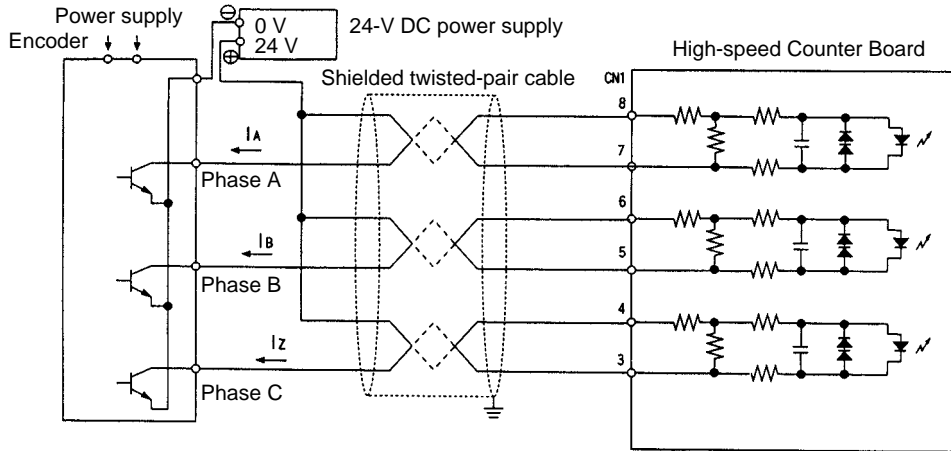

Connecting to an Encoder with a Line-driver Output (Am26LS31)

High-speed Counter Board in Differential Phase Mode

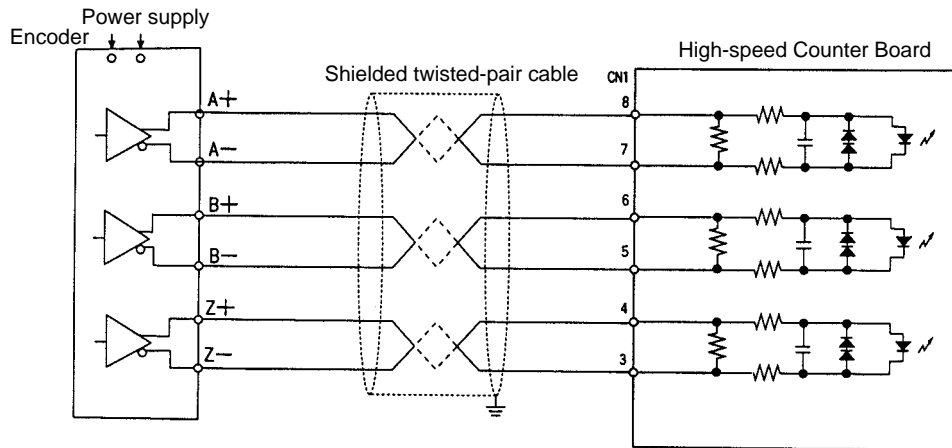
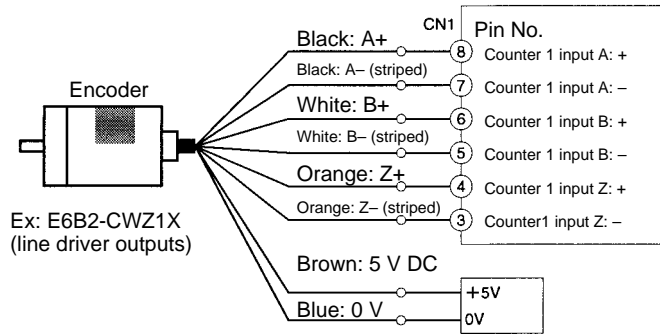

External Output Connections

The comparison results of high-speed counters 1 to 4 generate four external bit patterns. An OR is taken of corresponding bits in these 4-bit patterns, and the result is then output on external outputs 1 to 4. The bit patterns are set by the user when programming the comparison operation.

Connector	Pin no.	Name	Content
CN1	2	1OUT	External output 1
	1	2OUT	External output 2
	9	+DC	Power supply for external outputs 1 to 4: 24 V DC
CN2	8	3OUT	External output 3
	7	4OUT	External output 4
	15	-DC	Power supply for external outputs 1 to 4: 0 V

Note Switching between sourcing (PNP) outputs and sinking (NPN) outputs is accomplished using the PC Setup (DM 6602, DM 6611).

Example External Output Lines

Sourcing (PNP) Output

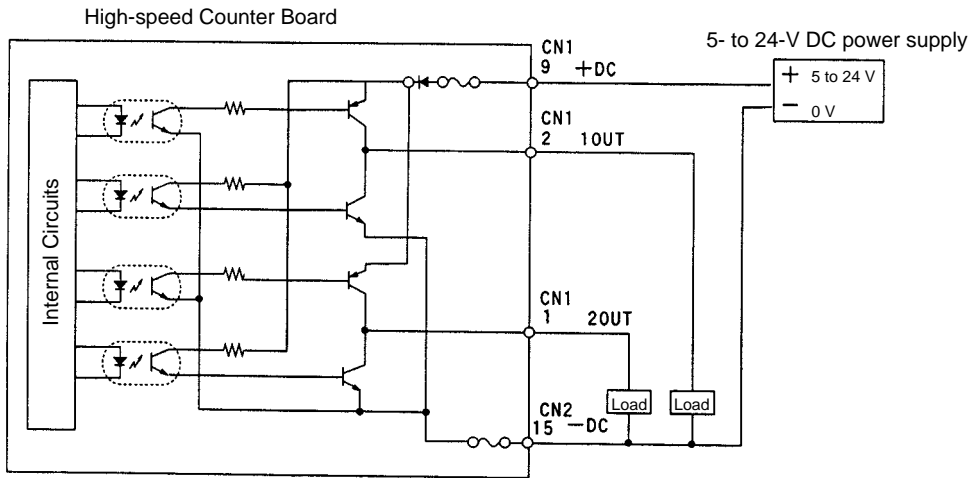

Sinking (NPN) Outputs

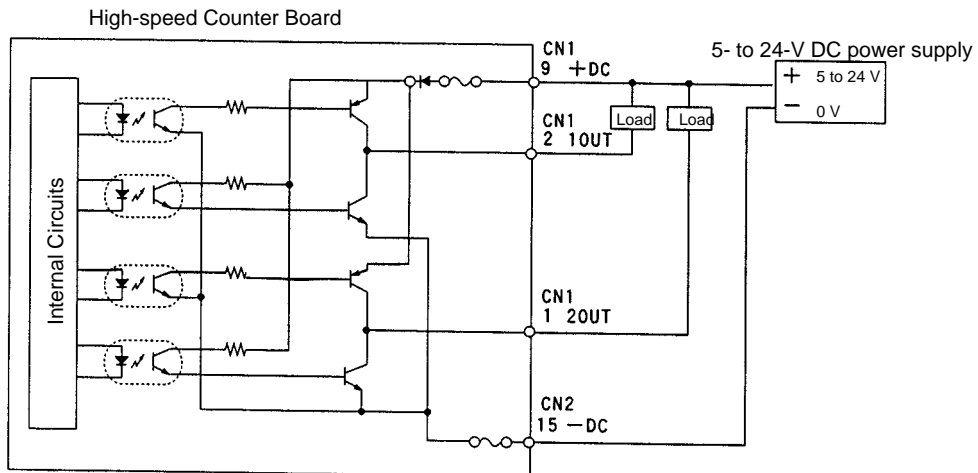

8-1-8 Specifications

Item	Specifications
Name	High-speed Counter Board
Model number	CQM1H-CTB41
Applicable CPU Units	CQM1H-CPU51/61
Unit classification	CQM1H-series Inner Board
Mounting locations and number of Boards	Maximum of two Boards can be mounted simultaneously in slots 1 and 2.
Pulse inputs	4 inputs (Refer to <i>High-speed Counter Specifications</i> below for details.)
External outputs	4 outputs (Refer to <i>External Output Specifications</i> below for details.)
Settings	Input voltage level switch
Indicators	Front: 18 LEDs 1 each of Ready (RDY) and Error (ERR) 4 each of phase A (A□), phase B (B□), phase Z (Z□), and external output (OUT□)
Front connections	Connectors CN1 and CN2 (Compatible connectors: Sockets & Hoods provided as standard accessories.)
Current consumption (Supplied from Power Supply Unit)	5 V DC 400 mA max.
Dimensions	25 × 110 × 107 mm (W × H × D)
Weight	90 g max.
Standard accessories	Sockets: XM2D-1501 (OMRON) x 2 Hoods: XM2S-1511 (OMRON) x 2

High-speed Counter Specifications

Counter Specifications

Item					Specifications		
Number of counters					4 counters (ports)		
Input Modes (Set in the PC Setup.)					Differential Phase Inputs	Up/Down Pulse Inputs	Pulse/Direction Inputs
Input pin No.	Port 1	Port 2	Port 3	Port 4	---		
	8 (7)	15 (14)	6 (5)	14 (13)	Phase-A input	Increment pulse input	Pulse input
	6 (5)	13 (12)	4 (3)	12 (11)	Phase-B input	Decrement pulse input	Direction input
	4 (3)	11 (10)	2 (1)	10 (9)	Phase-Z input	Reset input	Reset input
Input method					Switching between inputs using phase difference multiples of 1x, 2x, or 4x. (Set in the PC Setup.)	2, single-phase inputs	Single-phase pulse and direction inputs
Count frequency (Set for each port in the PC Setup.)					25 kHz (default) or 250 kHz	50 kHz (default) or 500 kHz	50 kHz (default) or 500 kHz
Count value					Linear Mode: –8388608 to 8388607 BCD, F8000000 to 07FFFFFF Hex Ring Mode: 00000000 to 08388607 BCD, 00000000 to 07FFFFFF Hex (Maximum value can be set to within the range 1 to 08388607 BCD, 1 to 07FFFFFF Hex with CTBL(63).)		

Item		Specifications
Storage location of counter PV		When mounted in slot 1: Port 1: IR 201 (leftmost digits) and IR 200 (rightmost digits) Port 2: IR 203 (leftmost digits) and IR 202 (rightmost digits) Port 3: IR 205 (leftmost digits) and IR 204 (rightmost digits) Port 4: IR 207 (leftmost digits) and IR 206 (rightmost digits) When mounted in slot 2: Port 1: IR 233 (leftmost digits) and IR 232 (rightmost digits) Port 2: IR 235 (leftmost digits) and IR 234 (rightmost digits) Port 3: IR 237 (leftmost digits) and IR 236 (rightmost digits) Port 4: IR 239 (leftmost digits) and IR 238 (rightmost digits) Data format: 8-digit BCD or 8-digit Hex (Set in the PC Setup: Bits 00 to 03 of DM 6602/DM 6611.) Linear Mode: F8388608 to 8388607 BCD (Leftmost digit is F Hex for negative numbers.) F8000000 to 07FFFFFF Hex Ring Mode: 00000000 to 08388607 BCD 00000000 to 07FFFFFF Hex
Control method	Target value match	Up to 48 target values and external/internal output bit patterns registered.
	Range comparison	Up to 16 upper limits, lower limits, and external/internal output bit patterns registered.
Counter reset method		Phase-Z Signal + Software Reset A counter is reset on the first phase-Z signal input after its Reset Bit (see below) is turned ON. Software Reset A counter is reset when its Reset Bit (see below) is turned ON. Reset Bits IR 21200 to IR 21203 (For ports 1 to 4 in slot 1) AR 0500 to AR 0503 (For ports 1 to 4 in slot 2)

Pulse Input Specifications

Item	Specifications			
Number of pulse inputs	4 inputs (Ports 1 to 4 = High-speed counters 1 to 4)			
Signals	Encoder inputs A and B; pulse input Z			
Input voltage	Switched by means of input voltage switch on the Board (Specified separately for phases A, B, and Z.)			
	24 V DC±10%		RS-422A line driver (AM26LS31 or equivalent)	
	Phase A and B	Phase Z	Phase A and B	Phase Z
Input current	5 mA typical	8 mA typical	10 mA typical	13 mA typical
ON voltage	19.6 V DC min.	18.6 V DC min.	---	---
OFF voltage	4.0 V DC min.	4.0 V DC min.	---	---

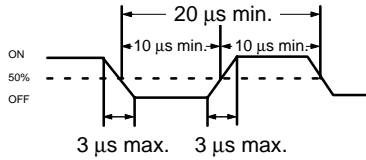
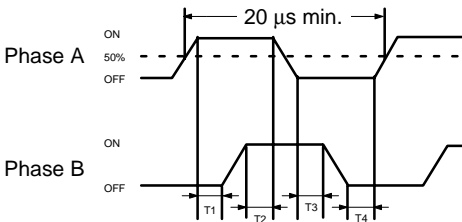
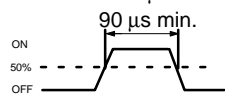
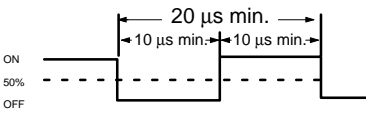
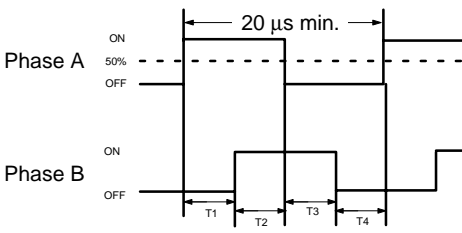
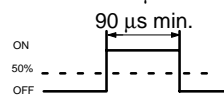
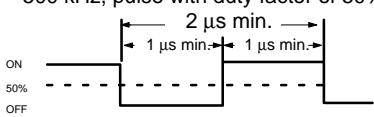
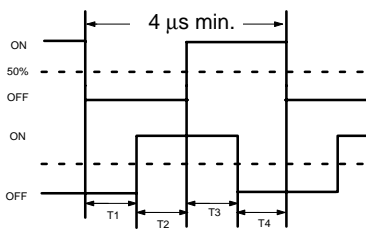
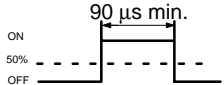
Item	Specifications	
<p>Min. response pulse</p> <p>50 kHz setting</p>	<p>Encoder inputs A and B Waveform of encoder inputs A and B Input rise/fall time: 3 μs max. 50 kHz, pulse with duty factor of 50%</p>  <p>3 μs max. 3 μs max.</p> <p>Relationship between phases A and B when phase differential input is used. T1, T2, T3, T4: 4.5 μs min. At least 4.5 μs must be provided to allow Phase A \leftrightarrow Phase B change.</p>  <p>Phase A</p> <p>Phase B</p> <p>Waveform of encoder input Z/Sensor input Pulse width must be 90 μs min.</p> 	<p>Encoder inputs A and B Waveform of + terminal 50 kHz, pulse with duty factor of 50%</p>  <p>20 μs min. 10 μs min. 10 μs min.</p> <p>Relationship between phases A and B when phase differential input is used. T1, T2, T3, T4: 4.5 μs min. At least 4.5 μs must be provided to allow Phase A \leftrightarrow Phase B change.</p>  <p>Phase A</p> <p>Phase B</p> <p>Waveform of encoder input Z/Sensor input Pulse width must be 90 μs min.</p> 
<p>500 kHz setting</p>	<p>The counting operation at 500 kHz is not reliable.</p>	<p>Encoder inputs A and B Waveform of + terminal 500 kHz, pulse with duty factor of 50%</p>  <p>2 μs min. 1 μs min. 1 μs min.</p> <p>Relationship between phases A and B when phase differential input is used. T1, T2, T3, T4: 1.0 μs min. At least 1.0 μs must be provided to allow Phase A \leftrightarrow Phase B change.</p>  <p>4 μs min.</p> <p>Phase A</p> <p>Phase B</p> <p>Waveform of encoder input Z/Sensor input Pulse width must be 90 μs min.</p> 

External Output Specifications

Item	Specifications
Number of external outputs	4 transistor outputs (Four outputs set together for sinking or sourcing outputs: Set in PC Setup)
Function	The target comparison or range comparison results of high-speed counters 1 to 4 output four user-defined 4-bit external bit patterns. An OR is taken of corresponding bits in these bit patterns, and the result is output on external outputs 1 to 4. Note External outputs 1 to 4 can be turned ON using IR 21300 to IR 21303 and AR 0600 to AR 0603.
External power supply	5 to 24 V DC±10%
Switching capacity	16 mA/4.5 V DC to 80 mA/26.4 V (see note)
Leakage current	0.1 mA max.
Residual voltage	0.8 V max.
Response for target matching	0.1 ms (This is the time required from completing target comparison until the external outputs are turned ON or OFF. The response time listed below must also be added.)
Response time	ON response: 0.1 ms max.; OFF response: 0.4 ms max.

Note The switching capacity is shown below.

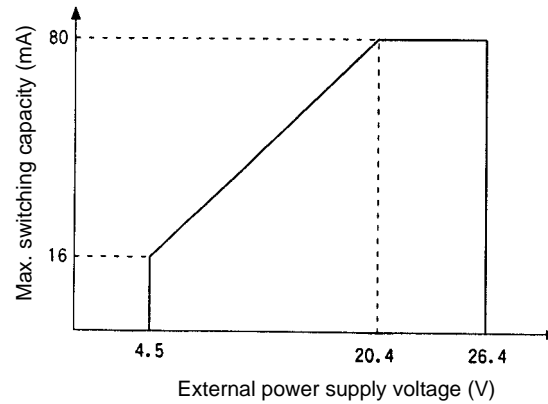

8-1-9 Internal Circuits

Pulse Inputs

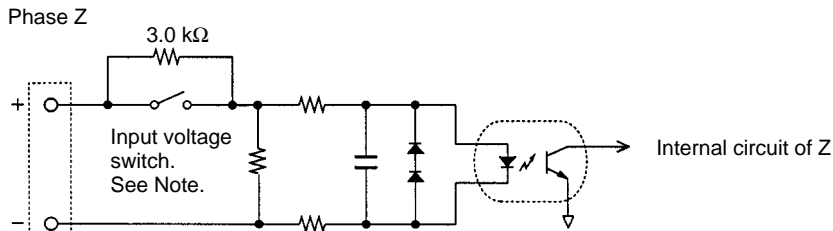
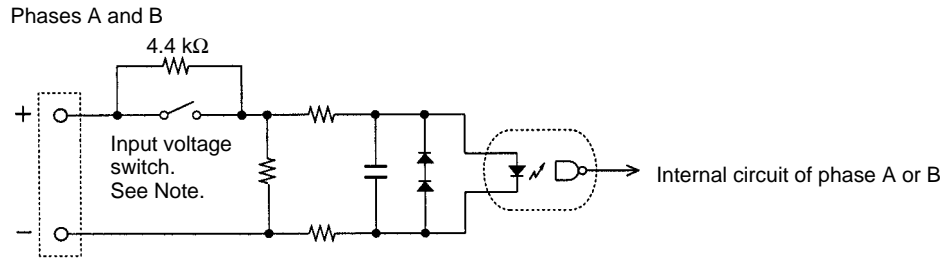

Note ON: Line driver input
OFF: 24-V DC input

External Outputs

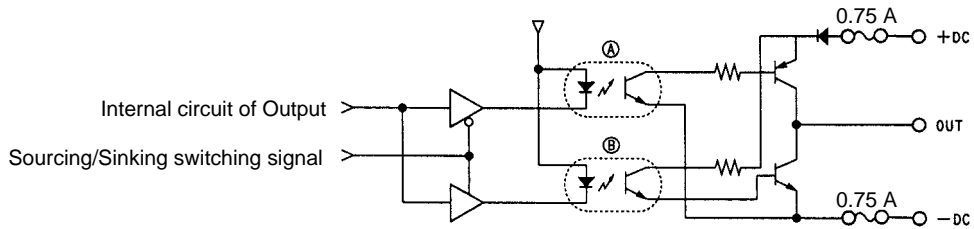

Note In the above figure, A is active when sourcing outputs are set, and B is active when sinking outputs are set.

8-2 Pulse I/O Board

8-2-1 Model

Name	Model	Specifications
Pulse I/O Board	CQM1H-PLB21	Two pulse input points and two pulse output points

8-2-2 Function

The Pulse I/O Board is an Inner Board that supports two pulse inputs and two pulse outputs.

Pulse Inputs 1 and 2

Pulse inputs 1 and 2 can be used as high-speed counters to count pulses input at either 50 kHz (signal phase) or 25 kHz (differential phase). Interrupt processing can be performed based on the present values (PV) of the counters.

Input Mode

The following three Input Modes are available:

- Differential Phase Mode (4x)

- Pulse/Direction Mode
- Up/Down Mode

Interrupts

The Board can be set to execute an interrupt subroutine when the value of the high-speed counter matches a specified target value, or an interrupt subroutine when the PV falls within a specified comparison range.

Pulse Outputs 1 and 2

Two 10 Hz to 50 kHz pulses can be output from port 1 and port 2. Both fixed and variable duty factors can be used.

- The fixed duty factor can raise or lower the frequency of the output from 10 Hz to 50 kHz smoothly.
- The variable duty factor enables pulse output to be performed using a duty factor ranging from 1% to 99%.

Note While pulse inputs and pulse outputs can be performed simultaneously, it is not possible to use all high-speed counter and pulse output functionality at the same time. The Port Mode Setting (High-speed Counter Mode/Simple Positioning Mode) in the PC Setup (DM 6611) will determine which has full functionality enabled.

Ports 1 and 2

Two pulse inputs (high-speed counter) and two pulse outputs can be used simultaneously via ports 1 and 2. To determine which has functional priority, the appropriate Port Mode setting must be entered in the PC Setup (DM 6611).

Mode	Content	High-speed counter functions		Pulse output functions			DM 6611 setting
		Reading PV with PRV(62)	High-speed counter interrupts with CTBL(63)	No trapezoidal acceleration/deceleration (SPED(64))	Identical acceleration/deceleration rates (PLS2(—))	Separate acceleration/deceleration rates (ACC(—))	
High-speed Counter Mode	High-speed counter given priority. All high-speed counter functions are enabled. Trapezoidal acceleration/deceleration for pulse outputs is limited.	Yes	Yes	Yes		Mode 0 disabled (Modes 1 to 3 enabled) See note 1.	0000 Hex
Simple Positioning Mode	Pulse output given priority. All pulse output functions are enabled. Interrupts for the high-speed counter are disabled.	Yes	No	Yes	Yes	Yes	0001 Hex

- Note**
1. Mode 0: Acceleration + Independent Mode; Mode 1: Acceleration + Continuous Mode; Mode 2: Deceleration + Independent Mode; Mode 3: Deceleration + Continuous Mode.
 2. The port modes for both ports 1 and 2 is always set to the same mode, i.e., either High-speed Counter Mode and Simple Positioning Mode. The mode cannot be set separately for each port.

8-2-3 System Configuration

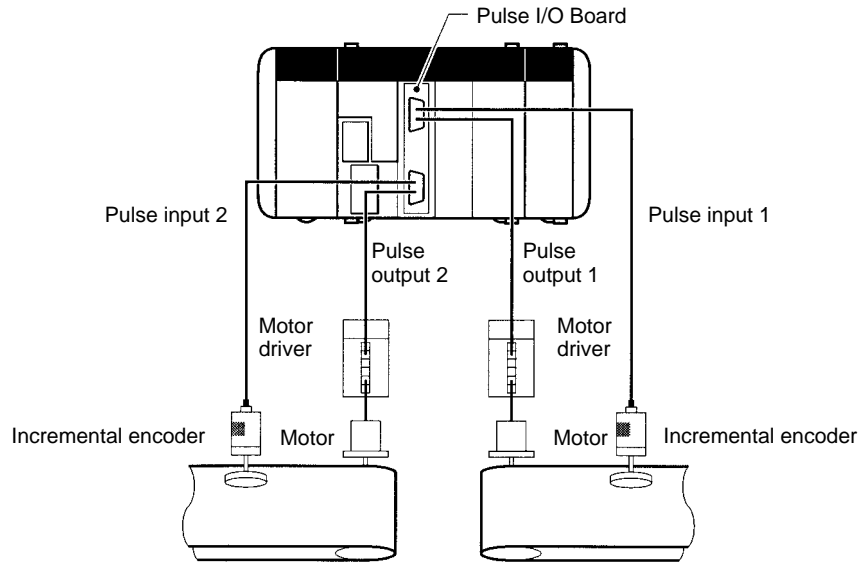

8-2-4 Applicable Inner Board Slot

The Pulse I/O Board can only be mounted in slot 2 (right slot) of the CQM1H-CPU51/61 CPU Unit.

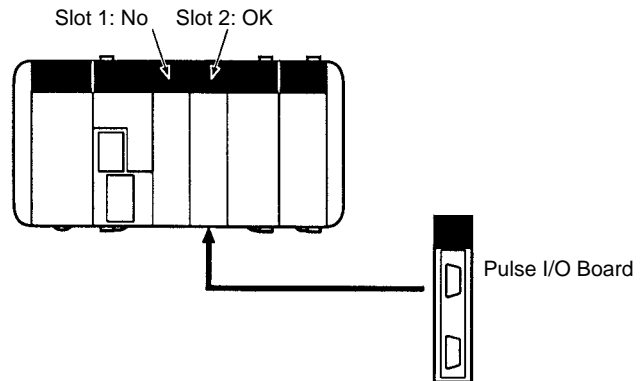

8-2-5 Names and Functions

The CQM1H-PLB21 Pulse I/O Board has a CN1 connector for pulse input 1 and pulse output 1, and a CN2 connector for pulse input 2 and pulse output 2.

CQM1H-PLB21 Pulse I/O Board

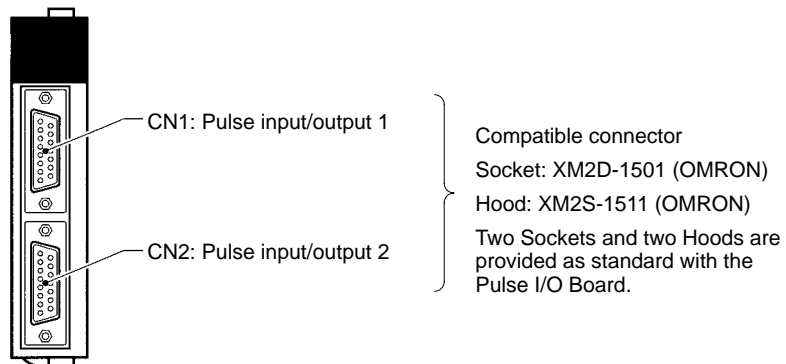

LED Indicators

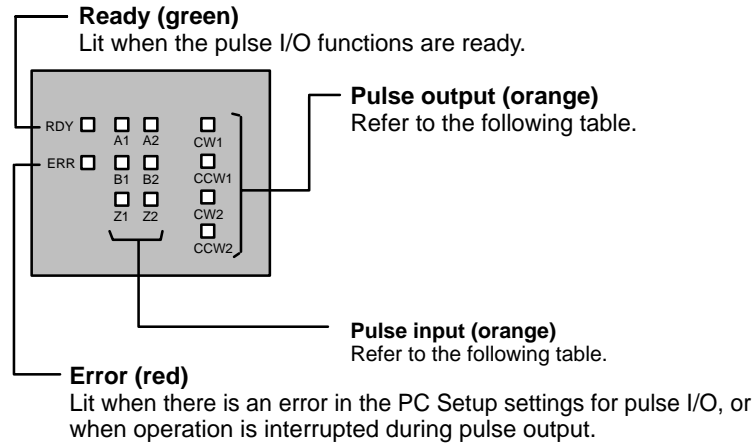

Pulse Output Indicators

Indicator	Port	Function
CW1	Port 1	Lit during CW pulse output to port 1.
CCW1		Lit during CCW pulse output to port 1.
CW2	Port 2	Lit during CW pulse output to port 2.
CCW2		Lit during CCW pulse output to port 2.

Pulse Input Indicators

Port 1	Port 2	Function
A1	A2	Lit when the phase-A pulse input is ON at the port.
B1	B2	Lit when the phase-B pulse input is ON at the port.
Z1	Z2	Lit when the phase-Z pulse input is ON at the port.

8-2-6 CN1 and CN2 Pin Arrangement

The pin arrangements of connectors CN1 and CN2 are identical.

Pin Arrangement	Pin No.	Name	Use
	1	Common input	Pulse input
	2	Pulse input Z: 24 V DC	
	3	Encoder input A: 24 V DC	
	4	Encoder input B: 24 V DC	
	5	CCW pulse output	Pulse output
	6	CW pulse output/PWM(—) output	
	7	5-V DC power supply for output	
	8	5-V DC power supply for output	Pulse input
	9	Pulse input Z: 12 V DC	
	10	Encoder input A: 12 V DC	
	11	Encoder input B: 12 V DC	
	12	Common output (0 V)	Pulse output
	13	CCW pulse output (with 1.6-kΩ resistance)	
	14	CW pulse output/PWM(—) output (with 1.6-kΩ resistance)	
	15	Power supply for output	---
Hood	Not used.		

Note Refer to *Appendix A Preparing Cables for Inner Boards* for information about using a compatible connector (XM2D-1501 Socket with XM2S-1511 Hood) to construct a cable.

8-2-7 Wiring Examples

Pulse Input Connections Connect the encoder output to CN1 and CN2 as shown below according to the port Input Mode.

CN1 pins Port 1	CN2 pins Port 2	Signal name	Encoder output		
			Differential Phase Mode	Pulse/Direction Mode	Up/Down Mode
3, 10	3, 10	Encoder input A	Encoder Phase A input	Directional signal input	Decrement pulse input
4, 11	4, 11	Encoder input B	Encoder Phase B input	Pulse input	Increment pulse input

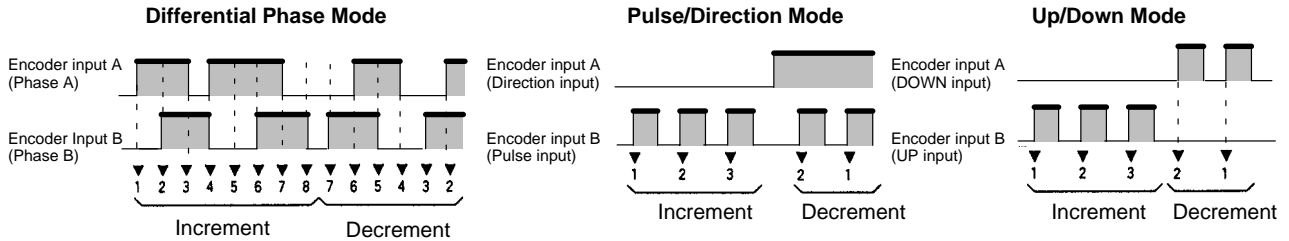

Note The function of encoder inputs A and B in Pulse/Direction Mode and Up/Down Mode differs from the High-speed Counter Board (CQM1H-CTB41).

Wiring Example

The example below shows connections to an encoder with phases A, B, and Z.

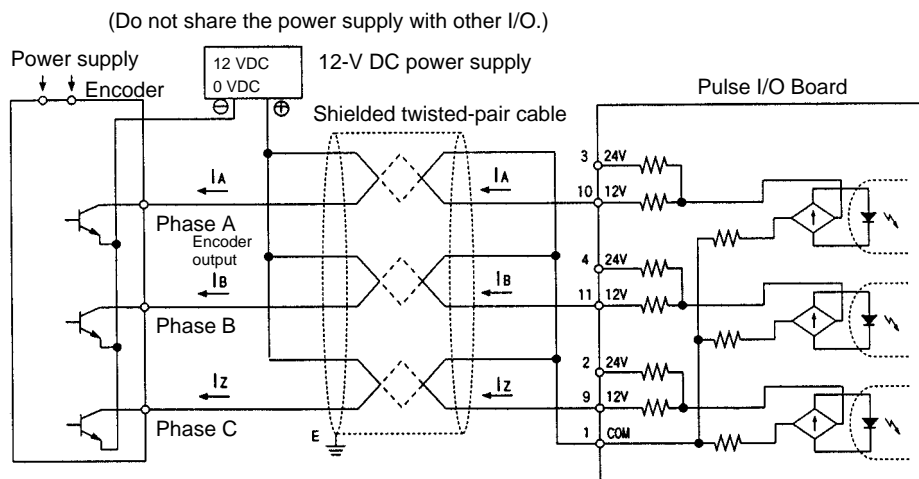
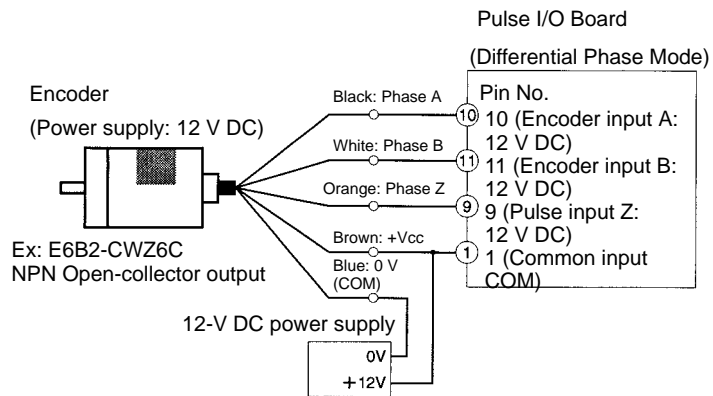

Pulse Output Connections

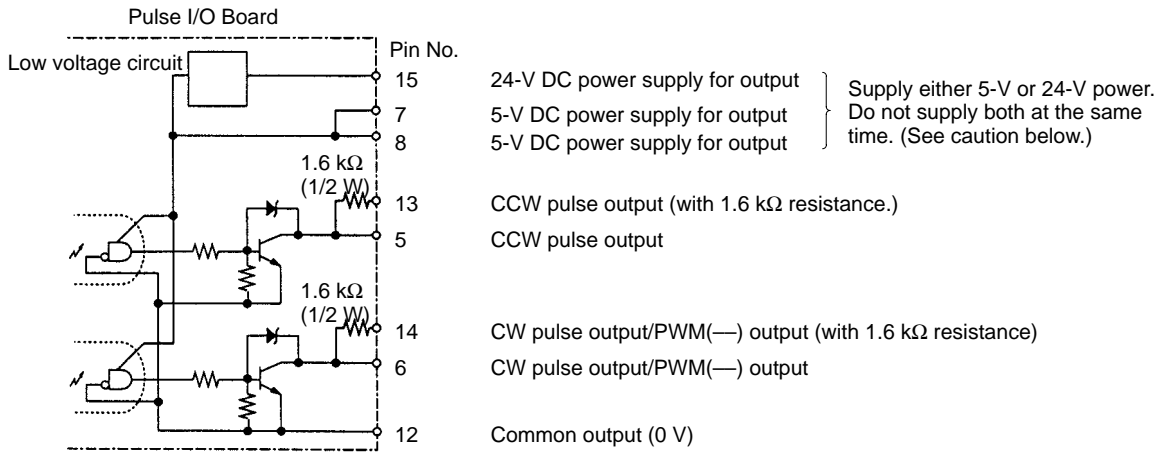

Caution Do not supply both 5-V and 24-V DC power at the same time. Doing so will damage the internal circuits.

Wiring Examples

The following examples show a Pulse I/O Board connected to a motor driver with a 5-V input.

Example 1: 5-V DC Power Supply

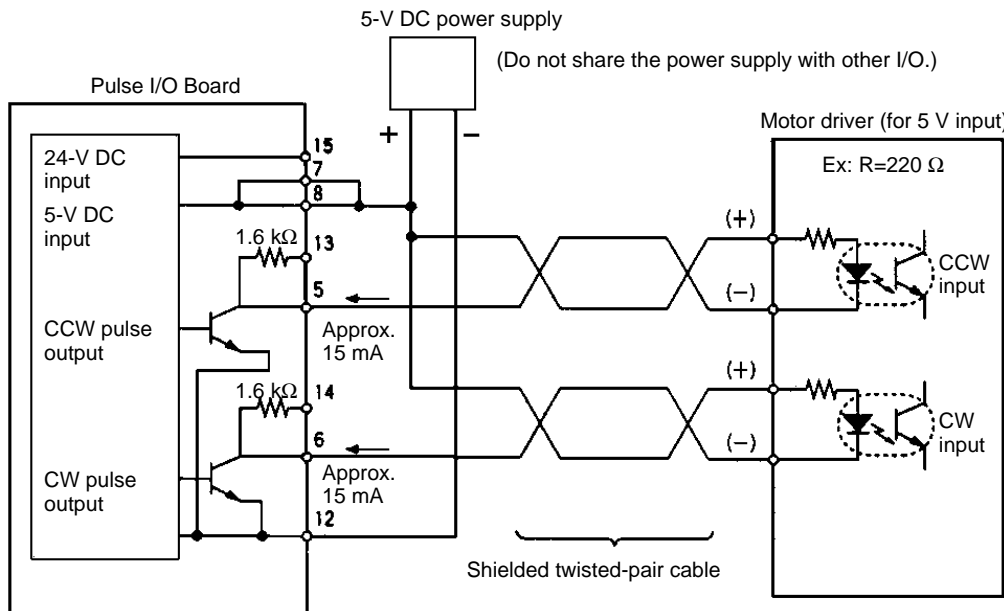

Example 2: 24-V DC Power Supply

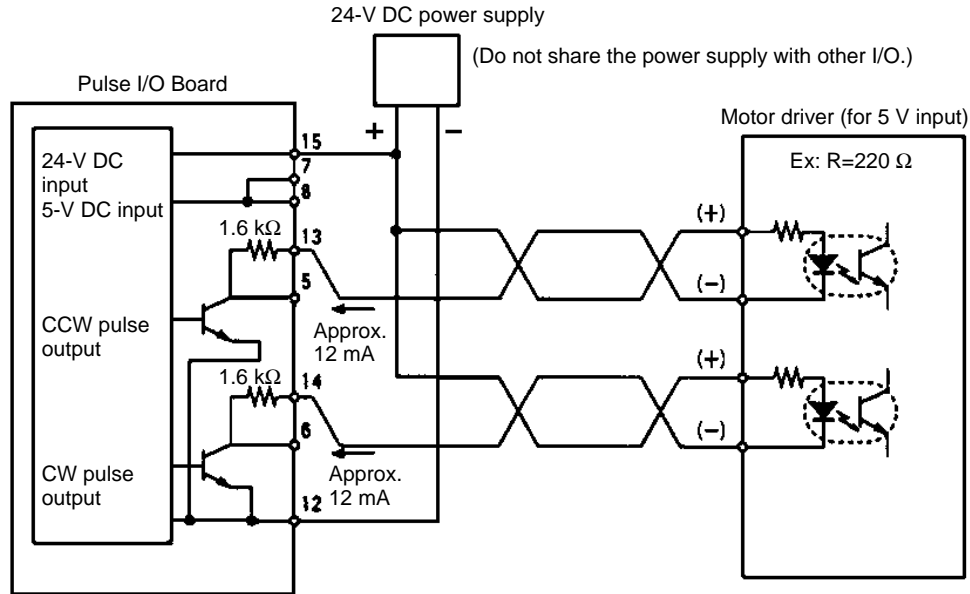

Note Here, a 5-V input motor driver is being used with a 24-V power supply. The internal resistance at the Pulse I/O Board (1.6 kΩ) is thus used. Care must be taken to avoid problems caused by the drive current at the motor driver.

Caution The 5-V DC or 24-V DC power supply for the outputs must be connected correctly.

Pulse Output Connection Precautions

- Connect a 7 to 30 mA load to the pulse output. Use a bypass resistor if the load is smaller than 7 mA.
- The pulse output circuits on pins 13 and 14 have a built-in resistance of 1.6 kΩ (1/2 W). Connect the pulse outputs as shown below according to the power supply and the motor driver specifications.

Open Collector Output

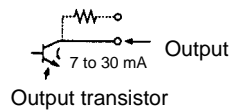

Output from Open Collector 1.6 kΩ Series Resistance

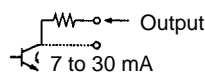

The internal 1.6-kΩ (1/2 W) resistance can be used as bypass resistance in the following way.

Example: 7 mA output transistor current = 4 mA load current + 3 mA bypass current

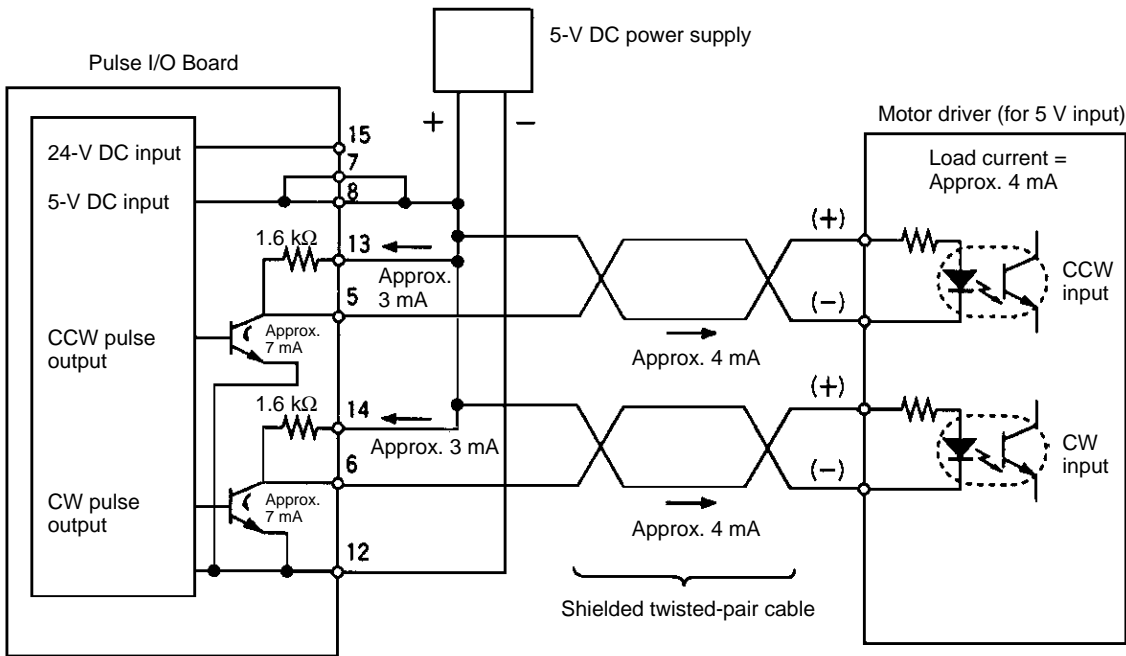

- The transistors of the internal circuits of the pulse output section are OFF when pulse output is stopped.

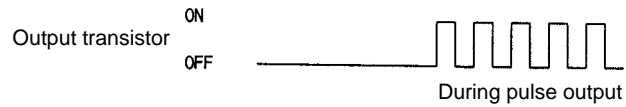

Example Configurations Using OMRON Servo Driver Cables

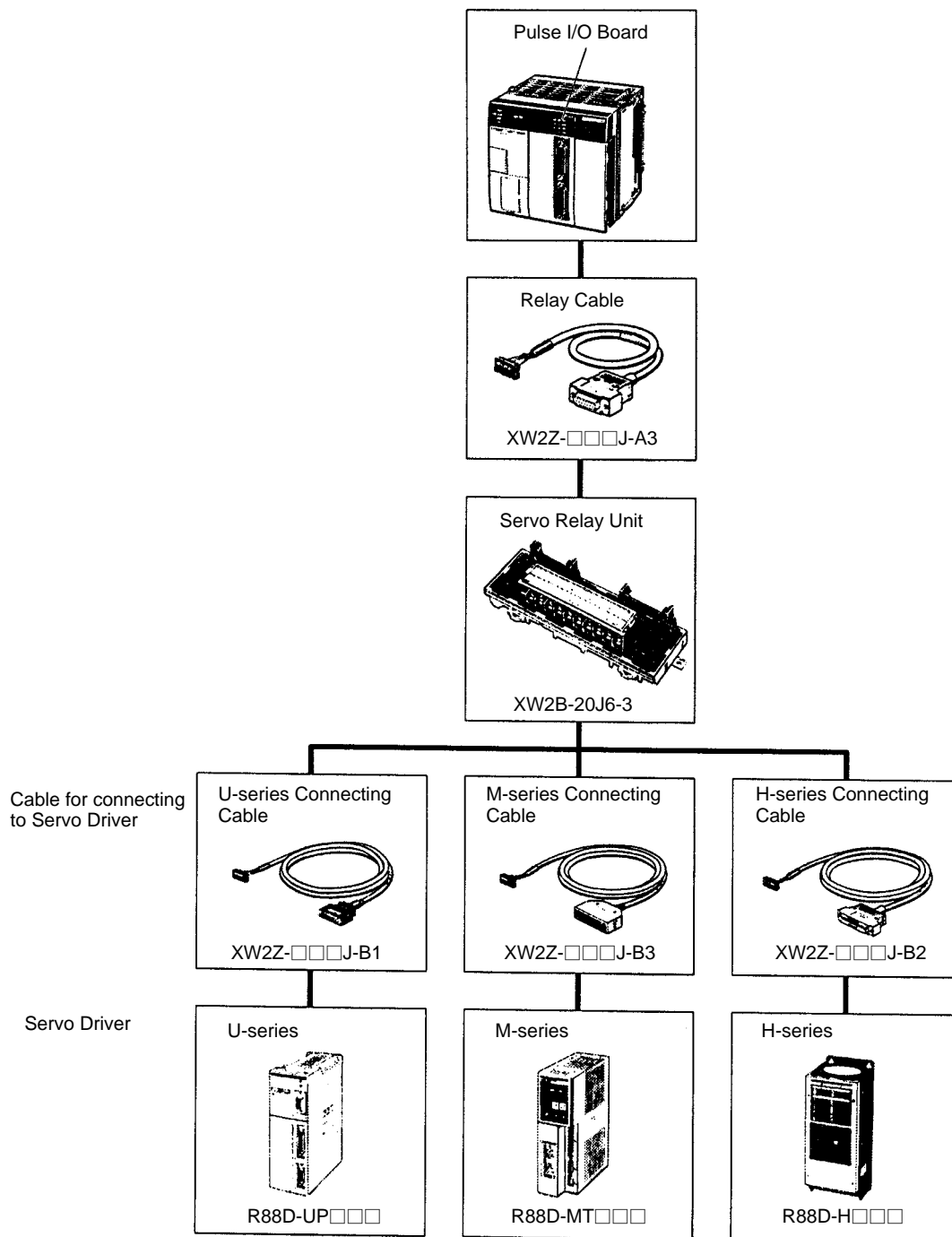

8-2-8 Specifications

Item	Specifications
Name	Pulse I/O Board
Model number	CQM1H-PLB21
Compatible CPU Units	CQM1H-CPU51/61
Unit classification	CQM1H-series Inner Board
Mounting locations and number of Boards	One in Inner Board slot 2 (right slot)
Pulse inputs	2 inputs (Refer to <i>High-speed Counter Pulse Inputs</i> below for details.)
Pulse outputs	2 outputs (Refer to <i>Pulse Outputs</i> below for details.)
Setting section	None
Indicators	Front: 12 LEDs 1 each of Ready (RDY) and Error (ERR) 2 each of phase A (A□), phase B (A□), phase Z (Z□), CW pulse (CW□), and CCW pulse (CCW□).
Front connection section	Connectors CN1 and CN2 (Compatible connector: Sockets & Hoods provided as standard accessories.)
Current consumption (Supplied from Power Supply Unit)	5 V DC 160 mA max.
Dimensions	25 × 110 × 107 mm (W × H × D)
Weight	90 g max.
Standard accessories	Sockets: XM2D-1501 (OMRON) × 2 Hoods: XM2S-1511 (OMRON) × 2

High-speed Counter Specifications

Counter Specifications

Item	Specifications
Number of counters	2 counters (ports)
Input Modes (Set for each port in the PC Setup.)	Differential phase input Pulse/Direction input Up/Down pulse input
Input pin No.	---
Port 1	3/10
Port 2	3/10
3/10	A-phase input
4/11	Direction input
4/11	B-phase input
2/9	Pulse input
2/9	Z-phase input
2/9	Reset input
Input method	Phase difference multiple of 4 (Fixed) Single-phase pulse + direction Single-phase pulse x 2
Count frequency	25 KHz 50 KHz 50 KHz
Count value	Linear Mode: -8388608 to 8388607 Ring Mode: 0 to 64999 (Maximum value can be set between 1 and 65000 with CTBL(63).)
Storage location of counter PV	Port 1: IR 233 (leftmost digits) and IR 232 (rightmost digits) Port 2: IR 235 (leftmost digits) and IR 234 (rightmost digits) Data format: 8-digit BCD Linear Mode: F8388608 to 8388607 (Leftmost digit is F Hex for negative numbers.) Ring Mode: 00000000 to 00064999
Control method	Target value Up to 48 target values and interrupt subroutine numbers registered. Range comparison Up to 8 upper limits, lower limits, and interrupt subroutine numbers registered.
Counter reset method	Phase-Z Signal + Software Reset A counter is reset on the first phase-Z signal input after its Reset Bit (see below) is turned ON. Software Reset A counter is reset when its Reset Bit (see below) is turned ON. Reset Bits Port 1: SR 25201 Port 2: SR 25202

Pulse Input Specifications

Item	Specifications			
Number of pulse inputs	2 inputs (Ports 1 and 2 = Pulses 1 to 2)			
Signal names	Encoder inputs A, encoder input B, pulse input Z			
Input voltage	Switched by means of connector pins (Can be specified separately for phases A, B, and Z.)			
	12 V DC±10%		24 V DC±10%	
Input current	Phase A, B	Phase Z	Phase A, B	Phase Z
	5 mA typical	12 mA typical	5 mA typical	12 mA typical
ON voltage	10.2 V DC min.		20.4 V DC min.	
OFF voltage	3.0 V DC min.		4.0 V DC min.	
Min. response pulse	<div style="display: flex; justify-content: space-between;"> <div style="width: 45%;"> <p>Encoder inputs A and B Waveform of encoder inputs A and B Input rise/fall time: 3 µsec. max. 50 kHz, pulse with duty factor of 50%</p> <p>3 µs max. 3 µs max.</p> <p>Relationship between phases A and B when phase differential input is used.</p> <p>T1, T2, T3, T4: 4.5 µs min. At least 4.5 µs must be allowed between Phase A and Phase B changes.</p> </div> <div style="width: 45%;"> <p>Pulse input Z Pulse width must be 0.1 ms min.</p> <p>0.1 ms min.</p> </div> </div>			

Pulse Output Specifications

Pulse Output Functions

Pulse output functions are determined by the output method, as indicated below.

Item	Specifications			
	Fixed duty factor			Variable duty factor
	Without trapezoidal acceleration/ deceleration	Same acceleration/ deceleration rates	Separate acceleration/ deceleration rates	
Instruction	PULS(65)/ SPED(64)	PLS2(—)	PULS(65)/ ACC(—)	PWM(—)
Output frequency	10 Hz to 50 kHz 10 Hz to 20 kHz for stepping motor	0 Hz to 50 KHz	100 Hz to 50 KHz	91.6 Hz, 1.5 KHz, 5.9 KHz
Output frequency pitch	1 or 10 Hz	10 Hz		---
Duty factor	50% fixed			1 to 99%
No. of output pulses	1 to 16777215			---
Acceleration/ Deceleration rate	---	10 Hz to 2 kHz (every 4.08 ms)		---

Output Specifications

Item	Specifications
No. of pulse outputs	2 outputs (Ports 1 and 2 = Pulse outputs 1 and 2)
Signal names	CW and CCW pulse output
Max. output frequency	50 kHz (20 kHz with stepping motor connected.)
External power supply	5 V DC±5% 30 mA min. 24 V DC +10%/−15% 30 mA min.
Max. switching capacity	NPN open collector, 30 mA/5 to 24 V DC±10%
Min. switching capacity	NPN open collector, 7 mA/5 to 24 V DC±10%
Leakage current	0.1 mA max.
Residual voltage	0.4 V max.
Pulse output specifications	

Pulse frequency	Switching current/Load power supply voltage			
	7 to 30 mA/5 V DC±10%		7 to 30 mA/24 V DC +10%/−15%	
	tON	tOFF	tON	tOFF
10 kpps max.	49.5 μs min.	48.5 μs min.	49.6 μs min.	46.0 μs min.
30 kpps max.	19.5 μs min.	18.5 μs min.	19.6 μs min.	16.0 μs min.
50 kpps max.	9.5 μs min.	8.5 μs min.	9.6 μs min.	6.0 μs min.

8-3 Absolute Encoder Interface Board

8-3-1 Model

Name	Model	Specifications
Absolute Encoder Interface Board	CQM1H-ABB21	2 inputs for absolute encoders

8-3-2 Functions

Absolute High-speed Counter with Interrupt Function

The Absolute Encoder Interface Board is an Inner Board that counts two gray binary code inputs from an absolute (ABS) rotary encoder.

The Absolute Encoder Interface Board reads binary gray codes (inverted binary codes) input from an absolute encoder through ports 1 and 2 at a maximum counting rate of 4 kHz, and performs processing according to the input values.

Operating Modes

BCD Mode and 360° Mode.

Resolutions

One of the following can be set: 8 bits (0 to 255), 10 bits (0 to 1023), or 12 bits (0 to 4095). The resolution should be set to match that of the encoder connected.

Interrupts

An interrupt subroutine can be executed when the PV (present value) of the absolute high-speed counter matches a specified target value or lies within a specified comparison range.

Note The use of an absolute encoder means that the position data can be retained even during power interrupts, removing the need to perform an origin return when power is returned. In addition, the origin compensation function allows the user to specify any position as the origin.

8-3-3 System Configuration

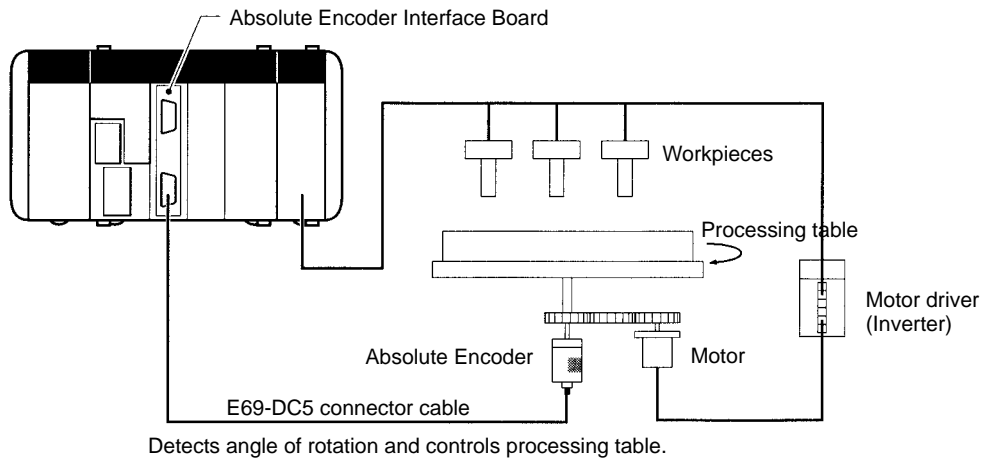

8-3-4 Applicable Inner Board Slots

The Absolute Encoder Interface Board can only be mounted in slot 2 (right slot) of the CQM1-CPU51/61 CPU Unit.

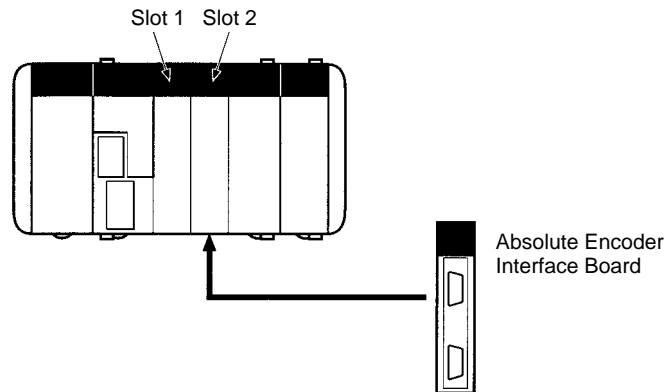

8-3-5 Names and Functions

The Absolute Encoder Interface Board is provided with port 1 connector CN1 and port 2 connector CN2 to receive binary gray code input from absolute rotary encoders.

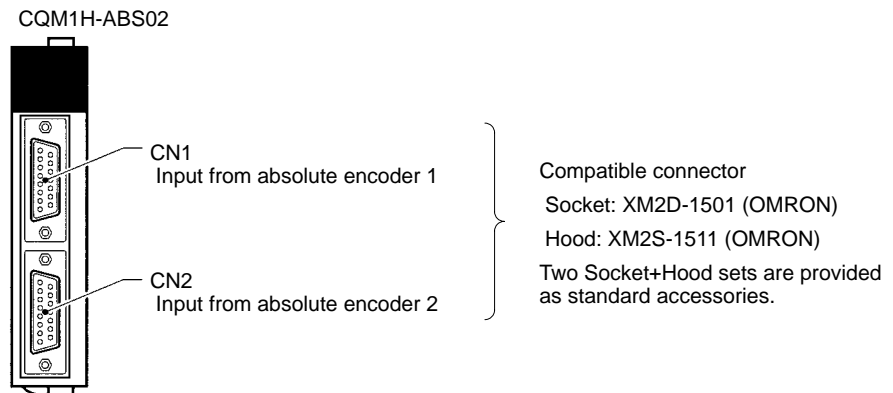

LED Indicators

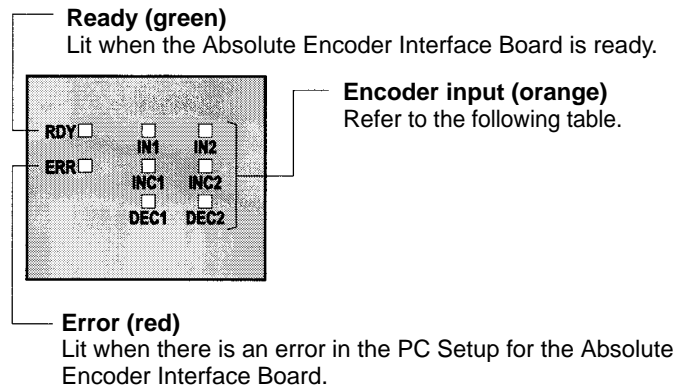

Encoder input indicators		Function
Port 1	Port 2	
IN1	IN2	Lit when input bit 0 is ON.
INC1	INC2	Lit when value input is incremented.
DEC1	DEC2	Lit when value input is decremented.

8-3-6 Pin Arrangement of Connectors CN1 and CN2

CN1 and CN2 have identical pin arrangements.

Pin arrangement	Pin No.	Name
	1	Common input
	2	Bit 2 ¹¹ of binary gray code from encoder
	3	Bit 2 ⁹ of binary gray code from encoder
	4	Bit 2 ⁷ of binary gray code from encoder
	5	Bit 2 ⁵ of binary gray code from encoder
	6	Bit 2 ³ of binary gray code from encoder
	7	Bit 2 ¹ of binary gray code from encoder
	8	Not used.
	9	Common input
	10	Bit 2 ¹⁰ of binary gray code from encoder
	11	Bit 2 ⁸ of binary gray code from encoder
	12	Bit 2 ⁶ of binary gray code from encoder
	13	Bit 2 ⁴ of binary gray code from encoder
	14	Bit 2 ² of binary gray code from encoder
	15	Bit 2 ⁰ of binary gray code from encoder
Hood	Not used.	

- Note**
1. Refer to *Appendix A Preparing Cables for Inner Boards* for information about using a compatible connector (XM2D-1501 Socket with XM2S-1511 Hood) to construct a cable. When connecting to an absolute encoder manufactured by OMRON, the E69-DC5 Absolute Encoder Interface Board Connecting Cable (described below) can be used.
 2. Only absolute encoders that produce binary gray code outputs can be used.

8-3-7 Wiring Examples

The following example shows a connection to an open-collector encoder.

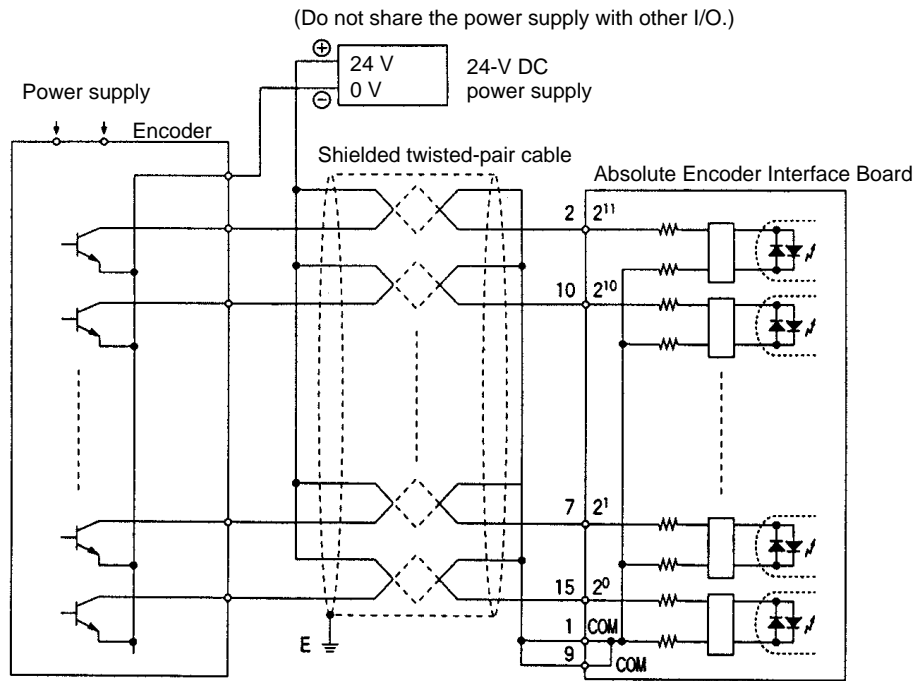

Connecting to an OMRON Absolute Encoder

When connecting to an Absolute Encoder manufactured by OMRON, connect the cables as shown in the following diagram.

Applicable Models:
E6F-AG5C-C
E6CP-AG5C-C
E6C2-AG5C-C

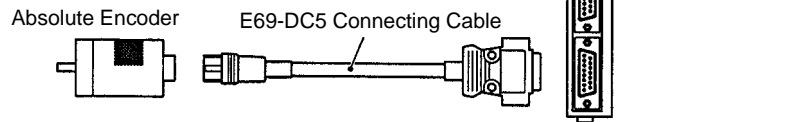

Applicable Cable: E69-DC5 Absolute Encoder Interface Board Connecting Cable (length: 5 m)

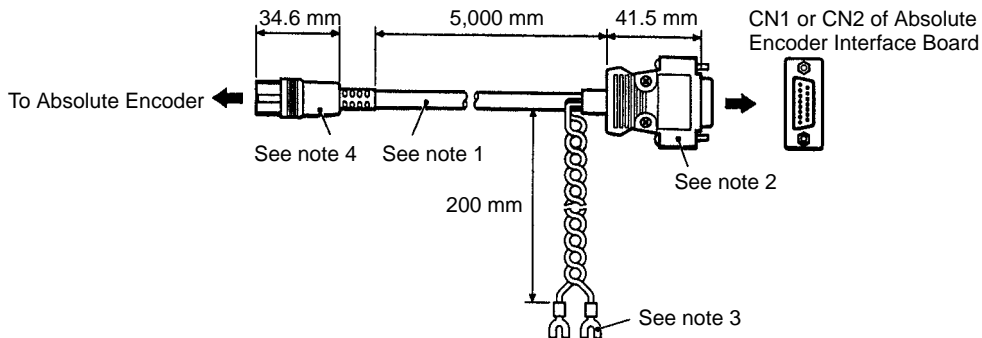

- Note**
1. A grease-proof PVC-insulated cable with external diameter of 6.12, seven conductors with diameters of 0.18 and standard length of 5 m is used.
 2. Connect to CQM1H-ABB21.
 3. Use 12 to 24 V DC.
 4. Connect to compatible encoder.

8-3-8 Specifications

Item	Specifications
Name	Absolute Encoder Interface Board
Model number	CQM1H-ABB21
Applicable CPU Unit	CQM1H-CPU51/61
Unit classification	CQM1H-series Inner Board
Mounting locations and number of Boards	1 Board can be mounted in slot 2.
Absolute Encoder inputs	2 inputs (Refer to <i>Pulse Inputs</i> below for details.)
Settings	None
Indicators	Front: Eight LEDs 1 each of Ready (RDY), Error (ERR) 2 each of Bit 2 ⁰ ON (IN□), Incrementing (INC□), and Decrementing (DEC□)
Front connections	Connectors CN1 and CN2 (Compatible connector: Sockets and Hood provided as standard accessories.)
Current consumption (Supplied from Power Supply Unit)	5 V DC 150 mA max.
Dimensions	25 × 110 × 107 mm (W × H × D)
Weight	90 g max.
Standard accessories	Sockets: XM2D-1501 (OMRON) x 2 Hoods: XM2S-1511 (OMRON) x 2

Absolute Encoder Input Specifications

Item	Specifications	
Number of input points	Two points	
Input code	Binary gray code	
Operating modes	BCD Mode or 360° Mode (Set in PC Setup.)	
Resolutions	8-bit, 10-bit, or 12-bit (Set in PC Setup.)	
Origin compensation	Yes (Current position can be designated as origin), compensation is set in PC Setup.	
Counting rate	4 kHz max.	
Storage locations of counter PVs	Port 1: IR 233 (leftmost digits) and IR 233 (rightmost digits) Port 2: IR 235 (leftmost digits) and IR 234 (rightmost digits) Data is stored as 4-digit BCD. Note The range of values is determined by the operating mode (BCD or 360°) and the resolution (8, 10, or 12 bits).	
Control methods	Target value match	Up to 48 target values and interrupt subroutine numbers registered.
	Range comparison	Up to 8 upper limits, lower limits, and interrupt subroutine numbers registered.

Pulse Inputs

Item	Specifications
Input voltage	24 V DC +10%, -15%
Input impedance	5.4 kΩ
Input current	4 mA typical
ON voltage	16.8 V DC min.
OFF voltage	3.0 V DC max.

8-3-9 Internal Circuit Configuration

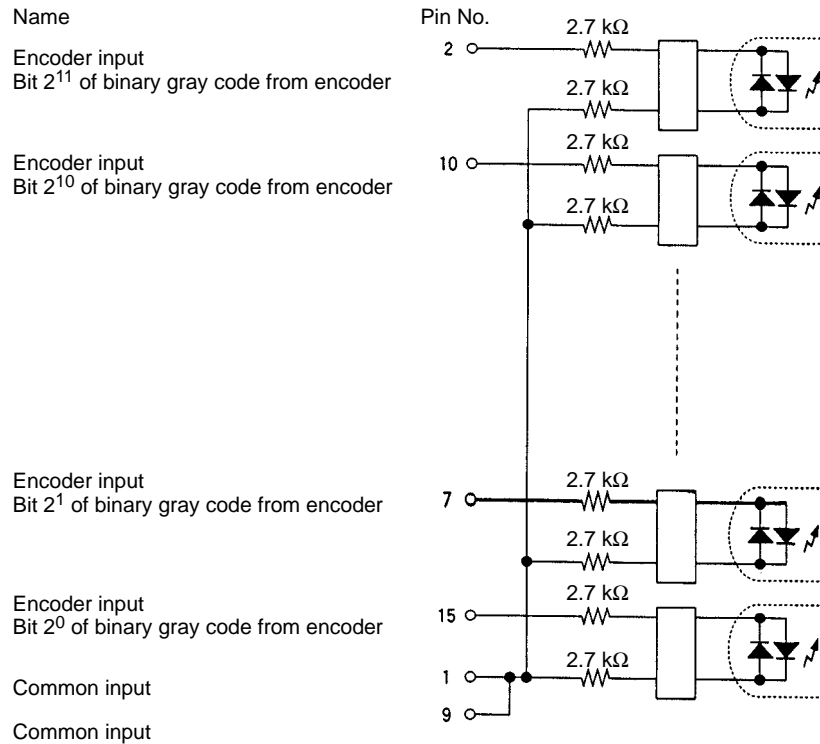

8-4 Analog Setting Board

8-4-1 Model

Name	Model	Specifications
Analog Setting Board	CQM1H-AVB41	Four analog setting screws

8-4-2 Function

Each of the values set using the four variable resistors located on the front of the Analog Settings Board is stored as a 4-digit BCD between 0000 and 0200 in the analog settings words (IR 220 to IR 223).

By using the Analog Setting Board, an operator can, for example, set the value of a timer instruction using an analog setting (IR 220 to IR 223), and thereby slightly speed up or slow down the speed or timing of a conveyor belt simply by adjusting a control with a screwdriver, removing the need for a Programming Device.

8-4-3 Applicable Inner Board Slots

The Analog Setting Board can be installed in either slot 1 (left slot) or slot 2 (right slot) of the CQM1H-CPU51/61 CPU Unit. Both slots, however, cannot be used at the same time.

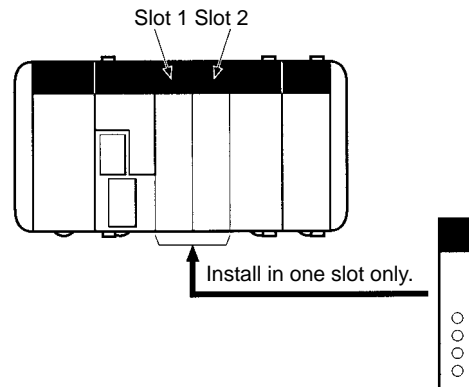

8-4-4 Names and Functions

The four analog controls of the Analog Setting Board are located on the front panel. The front panel does not have any indicators.

The value of the setting increases as the control is rotated clockwise. Use a small Philips screwdriver for this purpose.

Specifying IR 220 to IR 223 as the set value of a TIM instruction enables the Board to be used as an analog timer. When the timer is started, the analog settings are stored as the timer set value.

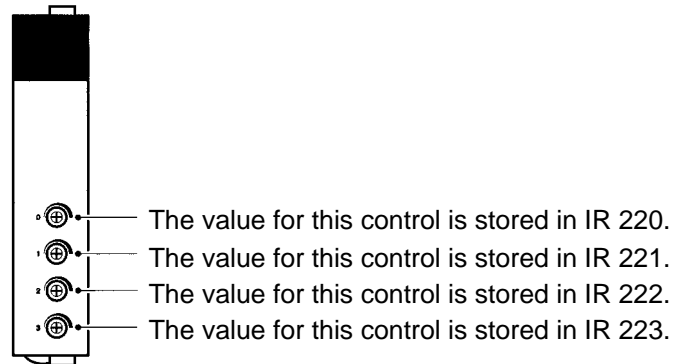

Caution While the power is turned ON, the contents of IR 220 to IR 223 are constantly refreshed with the values of the corresponding controls. Be sure that these words are not written to from the program or a Programming Device.

8-4-5 Specifications

Item	Specifications
Name	Analog Setting Board
Model number	CQM1H-AVB41
Applicable CPU Unit	CQM1H-CPU51/61
Unit classification	CQM1H-series Inner Board
Mounting locations and number of Boards	1 Board can be mounted in either slot 1 or slot 2. Note Both slots cannot be used at the same time.
Settings	4 analog (variable resistor) controls on front panel (Adjustable using Phillips screwdriver.) The setting of each control 0 to 3 is stored as a 4-digit BCD between 0000 and 0200 in IR 220 to IR 223 respectively.
Indicators	None
Front connections	None
Current consumption (Supplied from Power Supply Unit)	5 V DC 10 mA max.
Dimensions	25 × 110 × 107 mm (W × H × D)
Weight	60 g max.
Standard accessories	None

8-5 Analog I/O Board

8-5-1 Model

Name	Model	Specifications
Analog I/O Board	CQM1H-MAB42	4 analog inputs (–10 to +10 V; 0 to 5 V; 0 to 20 mA; separate signal range for each point) 2 analog outputs (–10 to +10 V; 0 to 20 mA; separate signal range for each point)

8-5-2 Function

The Analog I/O Board is an Inner Board featuring four analog inputs and two analog outputs.

The signal ranges that can be used for each of the four analog input points are –10 to +10 V, 0 to 5 V, and 0 to 20 mA. A separate range is set for each point. The settings in DM 6611 determine the signal ranges.

The signal ranges that can be used for each of the two analog output points are –10 to +10 V and 0 to 20 mA. A separate signal range can be selected for each point. Either a voltage output or current output is selected using the terminal (pins) connected on the connector.

Note Analog Input Averaging Function

The Analog I/O Board does not provide an averaging function such as the one provided by the CQM1-AD041. If data averaging is required, use the AVG (AVERAGE) instruction in the CPU Unit program.

8-5-3 System Configuration

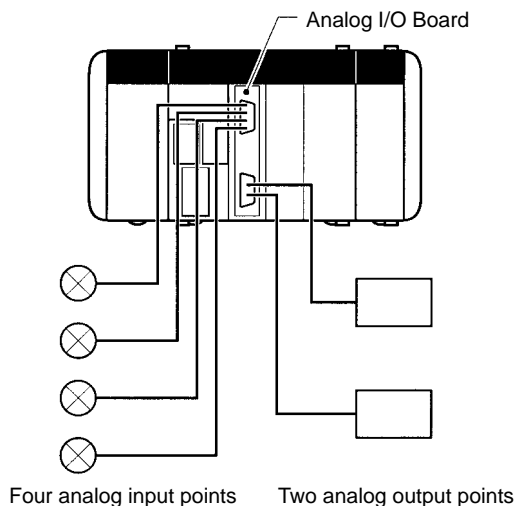

8-5-4 Applicable Inner Board Slot

The Analog I/O Board can only be mounted in slot 2 (right slot) of the CQM1H-CPU51/61 CPU Unit.

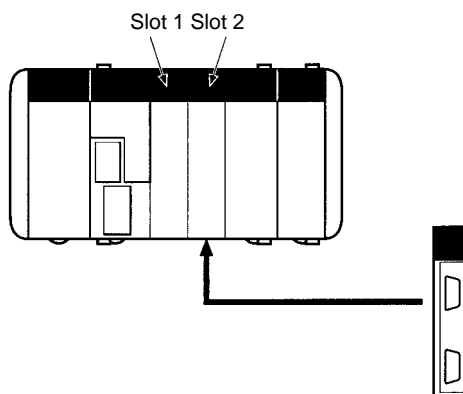

8-5-5 Names and Functions

The Analog I/O Board has a CN1 connector for the four analog inputs and a CN2 connector for 2 analog outputs.

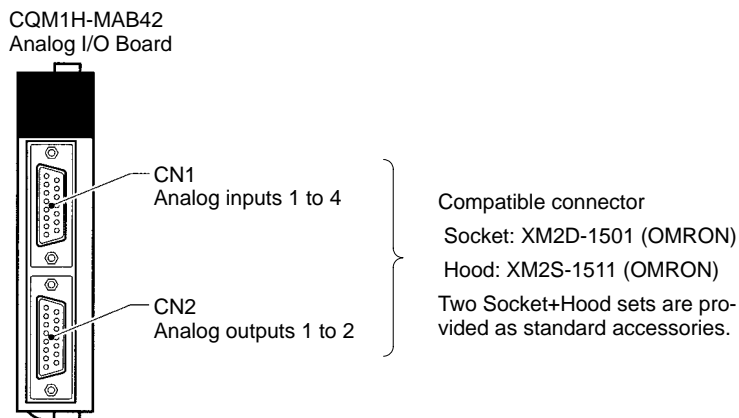

LED Indicators

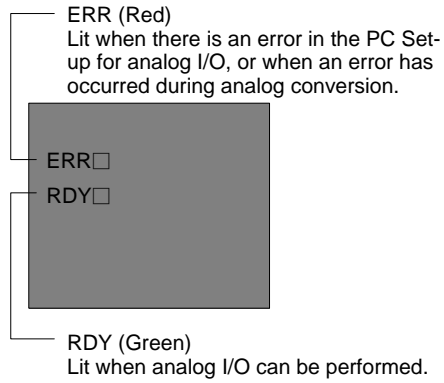

8-5-6 Pin Arrangement of Connectors CN1 and CN2

CN1: Analog Input

Pin arrangement	Pin No.	Name	Function
	1	V4+	Analog input 4: + voltage input
	2	V4-	Analog input 4: common (- voltage input, - current input)
	3	V3+	Analog input 3: + voltage input
	4	V3-	Analog input 3: common (- voltage input, - current input)
	5	V2+	Analog input 2: + voltage input
	6	V2-	Analog input 2: common (- voltage input, - current input)
	7	V1+	Analog input 1: + voltage input
	8	V1-	Analog input 1: common (- voltage input, - current input)
	9	I4+	Analog input 4: + current input
	10	NC	Not used.
	11	I3+	Analog input 3: + current input
	12	NC	Not used.
	13	I2+	Analog input 2: + current input
	14	NC	Not used.
	15	I1+	Analog input 1: + current input
Hood	NC	Not used.	

CN2: Analog Output

Pin arrangement	Pin No.	Name	Function
	1	NC	Not used.
	2	NC	Not used.
	3	I2-	Analog output 2: common (- current output)
	4	V2-	Analog output 2: common (- voltage output)
	5	NC	Not used.
	6	NC	Not used.
	7	I1-	Analog output 1: common (- current output)
	8	V1-	Analog output 1: common (- voltage output)
	9	NC	Not used.
	10	I2+	Analog output 2: + current output
	11	V2+	Analog output 2: + voltage output
	12	NC	Not used.
	13	NC	Not used.
	14	I1+	Analog output 1: + current output
	15	V1+	Analog output 1: + voltage output
Hood	NC	Not used.	

Note Refer to *Appendix A Preparing Cables for Inner Boards* for information about using a compatible connector (XM2D-1501 Socket with XM2S-1511 Hood) to construct a cable.

8-5-7 Wiring Examples

Analog Input Connections

The input signal connections to CN1 depend on whether the input signals are voltage inputs or current inputs. The following diagrams show the correct wiring in each case.

Voltage Inputs
(-10 to +10 V, 0 to 10 V, or 0 to 5 V)

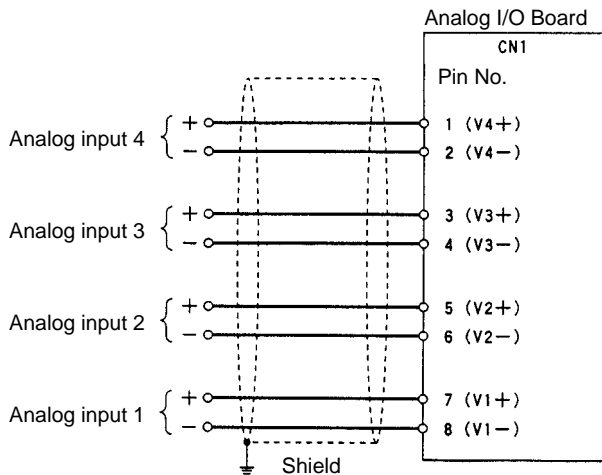

Current Inputs
(0 to 20 mA)

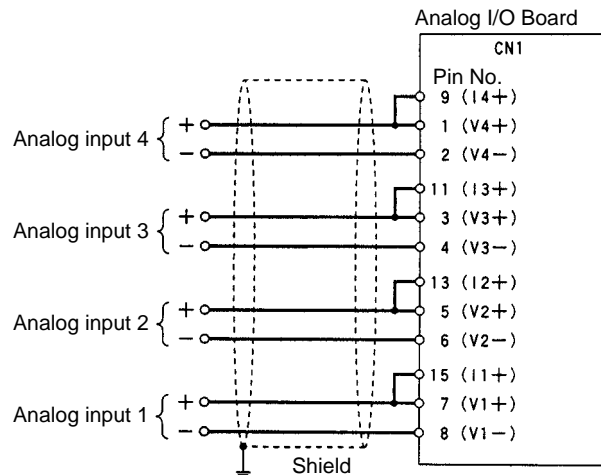

Analog Output Connections

The output signal connections to CN2 depend on whether the output signals are voltage outputs or current outputs. The following diagrams show the correct wiring in each case.

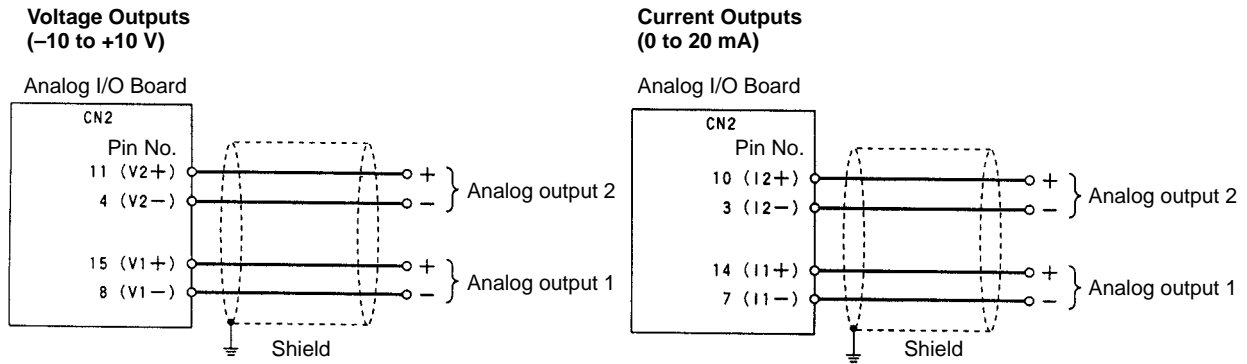

8-5-8 Specifications

Item	Specifications
Name	Analog I/O Board
Model number	CQM1H-MAB42
Applicable CPU Unit	CQM1H-CPU51/61
Unit classification	CQM1H-series Inner Board
Mounting locations and number of Boards	1 Board in Inner Board slot 2 (right slot)
Analog inputs	4 inputs (Refer to <i>Analog Inputs</i> below for a details.)
Analog outputs	2 outputs (Refer to <i>Analog Outputs</i> below for a details.)
Isolation method	Between inputs and PC: Photocoupler isolation Between inputs: No isolation
Settings	None
Indicators	2 LED indicators on front panel: Ready (RDY) and Error (ERR)
Front connection section	Connectors CN1 and CN2 (Compatible connector: Sockets & connectors provided as standard accessories.)
Current consumption (Supplied from Power Supply Unit)	5 V DC 400 mA max.
Dimensions	25 × 110 × 107 mm (W × H × D)
Weight	100 g max.
Standard accessories	Sockets: XM2D-1501 (OMRON) x 2 Hoods: XM2S-1511 (OMRON) x 2

Analog Inputs

Item		Specifications	
Input signals		Voltage inputs	Current inputs
Number of analog input points		4 inputs	
Input signal ranges (See note 1)		-10 to 10 V 0 to 10 V 0 to 5 V	0 to 20 mA
Analog input storage words		Analog input 1: IR 232 Analog input 2: IR 233 Analog input 3: IR 234 Analog input 4: IR 235	
A/D conversion time (See note 2)		1.7 ms max./point	
Resolution		1/4,096	
A/D conversion output data		12-bit binary data -10 to +10 V: F800 to 07FF Hex 0 to 10 V, 0 to 5 V: 0000 to 0FFF Hex Note Negative voltages (-10 V ≤ input voltage < 0 V) are stored as two's complements.	12-bit binary data 0 to 20 mA: 0000 to 0FFF Hex
External input impedance		1 MΩ typical	250 Ω typical
Absolute maximum rated input		±15 V	±30 mA
Overall precision (See note 3)	23±2°C	±0.5% of FS	
	0 to 55°C	±1.0% of FS	
Control Bits		PC Setup settings are used to determine whether or not to convert analog signals into binary data for each input.	

- Note**
1. Separate input signal ranges can be set for each input.
 2. The A/D conversion time is the time taken for an analog signal to be stored in memory as digital data. At least one cycle is required to transfer the data to the CPU Unit.
 3. The overall precision is the precision with respect to full scale.

Analog Outputs

Item		Specifications	
Output signals		Voltage outputs	Current outputs
Number of analog output points		2 outputs	
Output signal ranges (See note 1)		-10 to 10 V	0 to 20 mA
D/A conversion time (See note 2)		1.7 ms max./2 points	
Resolution		1/4,095	1/2,047
Analog output setting storage words		Analog output 1: IR 236 Analog output 2: IR 237	
External output impedance		2 kΩ min.	350 Ω max.
Setting data		12-bit binary data -10 to +10 V: F800 to 07FF Hex Note Negative voltages outputs (-10 V ≤ output voltage < 0 V) need to be stored as two's complements.	11-bit binary data 0 to 20 mA: 0000 to 07FF Hex
Overall precision (See note 2)	23±2°C	±0.5% of FS	
	0 to 55°C	±1.0% of FS	

- Note**
1. Different terminals are used for each output, allowing output signal ranges to be selected for each output.
 2. The D/A conversion time is the time taken to convert the data in the CPU Unit and output it. At least one cycle is required to transfer the data from the CPU Unit to the Analog I/O Board.
 3. The overall precision is the precision with respect to full scale.

8-5-9 Internal Circuit Configuration

Analog Inputs

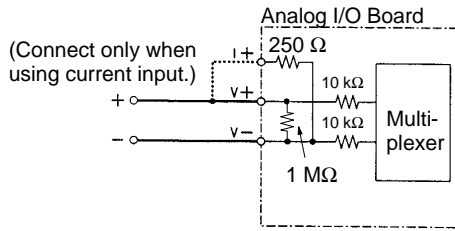

Analog Outputs

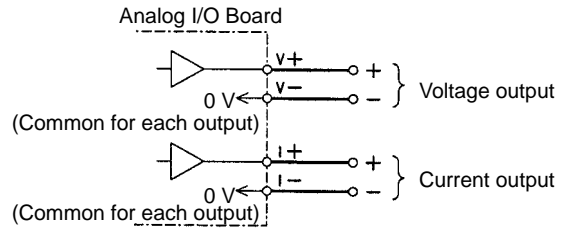

8-6 Serial Communications Board

This section provides an introduction to the Serial Communications Board. Detailed information can be found in the *Serial Communications Board Operation Manual* (W365).

8-6-1 Model Number

Name	Model	Specifications
Serial Communications Board	CQM1H-SCB41	One RS-232 port One RS-422A/485 port

8-6-2 Serial Communications Boards

The Serial Communications Board is an Inner Board for the CQM1H-series PCs. One Board can be installed in Inner Board slot 1 of a CQM1H-series CPU Unit. The Board cannot be installed in slot 2.

The Board provides two serial communications ports for connecting host computers, Programmable Terminals (PTs), general-purpose external devices, and Programming Devices (excluding Programming Consoles). This makes it possible to easily increase the number of serial communications ports for a CQM1H-series PC.

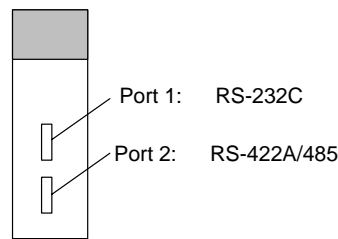

8-6-3 Features

The Serial Communications Board is an option that can be mounted in the CPU Unit to increase the number of serial ports without using an I/O slot. It supports protocol macros (which are not supported by the ports built into the CPU Units), allowing easy connection to general-purpose devices that have a serial port.

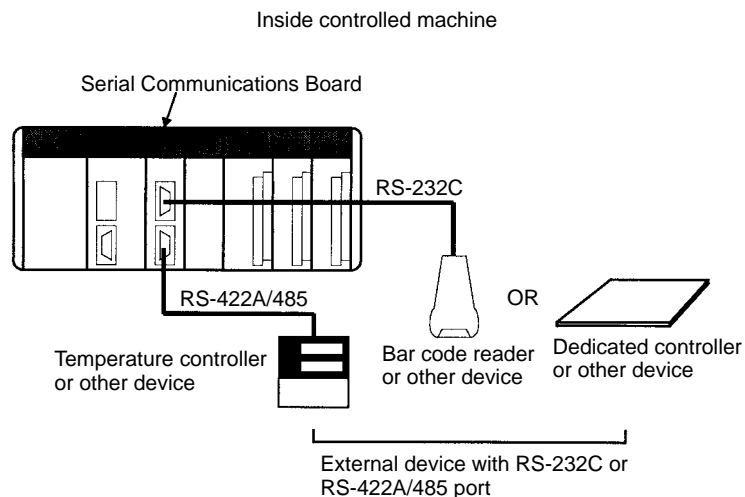

Both RS-232C and RS-422A/485 ports are provided. The RS-422A/485 port enables 1:N connections to general-purpose external devices without going through Converting Link Adapters. The 1:N connections can be used with protocol macros or 1:N-mode NT Links.

8-6-4 System Configuration

The following serial communications modes are supported by the Serial Communications Board: Host Link (SYSMAC WAY), protocol macro, no-protocol, 1:1 Data Links, 1:N-mode NT Link, and 1:1-mode NT Link modes. The devices shown in the following diagram can be connected.

Note The 1:1-mode NT Link and 1:N-mode NT Link communications modes use different protocols that are not compatible with each other.

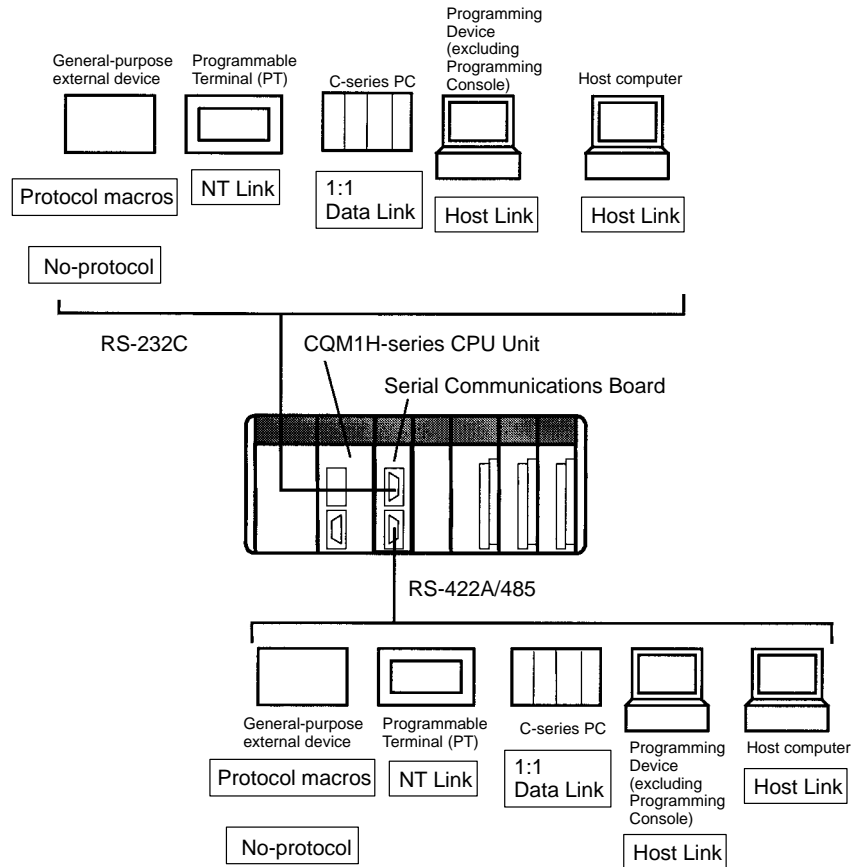

Note An NT-AL001-E Converting Link Adapter can be used to convert between RS-232C and RS-422A/485. This Link Adapter requires a 5-V power supply. Power is provided by the RS-232C port on the Serial Communications Board when the Link Adapter is connected to it, but must be provided separately when connecting the Link Adapter to other devices.

SECTION 9

Battery Maintenance

This section describes the maintenance of the battery that backs up memory in the CPU Unit, including the replacement procedure.

- 9-1 Battery Replacement
- 9-2 Battery Life
- 9-3 Replacement Procedure

9-1 Battery Replacement

The CPU Unit contains a CPM2A-BAT01 Battery Set that must be replaced when its effective life has expired. The effective life under normal conditions is approximately 5 years. The effective life will be reduced at higher temperatures.

A battery error will occur when the voltage of the battery starts to drop, causing the ERR/ALM indicator to flash, causing SR 25308 to turn ON, and generating a battery error message readable from Programming Devices. The battery must be replaced within one week after a battery error is indicated.

Caution Replace the battery within one week after the first indication that the battery requires replacement. Always keep a spare Battery Set on hand. It will be highly unlikely that you will be able to obtain a replacement Battery Set in time otherwise. If the battery is not replaced in time, the user program and other data may be lost.

9-2 Battery Life

The built-in battery is used for retaining the status of the HR and DM areas, the user's program, and other specified status while power is not being supplied to the CQM1H. The total number of hours that the battery can provide backup power will vary as shown below, depending on the ambient temperature and whether or not a Memory Cassette with a clock is installed.

Memory Cassette with clock	Total hours with no current supplied	
	Guaranteed time (see note 1)	Actual capacity (see note 2)
No	11,000 h (Approx. 1 yr.)	43,000 h (Approx. 5 yr.)
Yes	9,700 h (Approx. 1 yr.)	

- Note**
1. Total hours with no current supplied, at an ambient temperature of 55°C.
 2. Total hours with no current supplied, at an ambient temperature of 25°C.

Total Time with No Current Supplied (in Years)

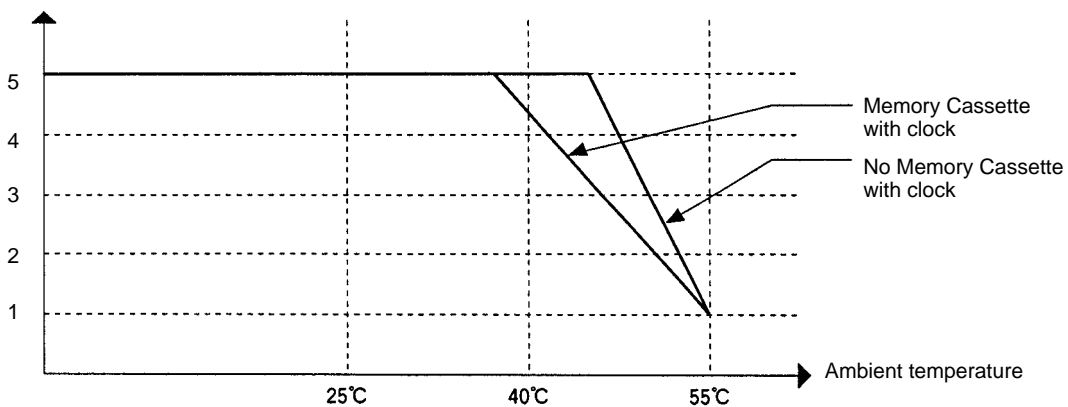

- Note**
1. The values in the above graph are reference values.
 2. The effective life of the battery is five years. Replace the battery every five years even if it could be used longer.

9-3 Replacement Procedure

Use the following procedure to replace the battery. You must complete this procedure within five minutes after turning OFF the power to the CQM1H to ensure memory backup.

- 1, 2, 3...
1. Turn OFF the power to the CQM1H.
- or If the CQM1H has not been ON, turn it ON for at least five minutes and then turn it OFF.

Note If power is not turned ON for at least five minutes before replacing the battery, the capacitor that backs up memory when the battery is removed will not be fully charged and memory may be lost before the new battery is inserted.

2. Open the compartment on the upper left of the CPU Unit and carefully draw out the battery.
3. Remove the battery connector.
4. Connect the new battery, place it into the compartment, and close the cover.

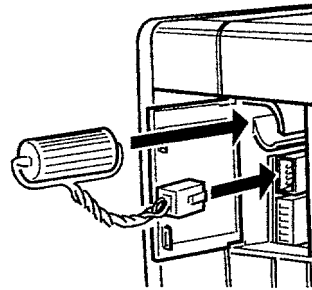

The battery error will automatically be cleared when a new battery is inserted.

⚠ WARNING Never short-circuit the battery terminals; never charge the battery; never disassemble the battery; and never heat or incinerate the battery. Doing any of these may cause the battery to leak, burn, or rupturing resulting in injury, fire, and possible loss of life or property.

Appendix

Preparing Cables for Inner Boards

This appendix describes methods for creating CN1 and CN2 cables for the following Inner Boards. The methods are the same for all the Boards.

- CQM1H-CTB41 High-speed Counter Board
- CQM1H-PLB21 Pulse I/O Board
- CQM1H-ABB21 Absolute Encoder Interface Board
- CQM1H-MAB42 Analog I/O Board

Applicable Connector (on the Cable)

Use the following products or equivalents for the connector on the cable.

Socket: XM2D-1501 (OMRON)

Hood: XM2S-1511 (OMRON)

Two of each of the above products are provided as standard accessories for the CQM1H-CTB41/PLB21/ABB21/MAB42 Inner Boards.

Cable

Use shielded twisted-pair wire for the cable.

Wiring and Assembly

The following illustrations show the procedure for wiring and assembly of the connectors. First pass the signal wires through heat-shrinking tubes and solder them to the socket pins.

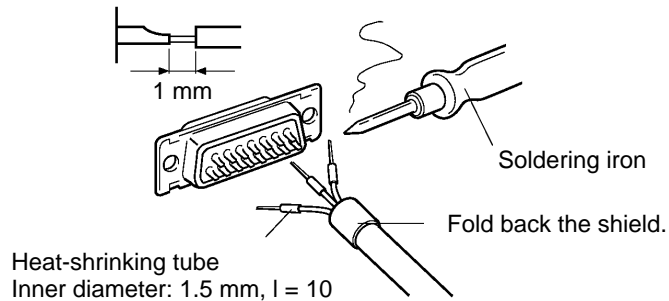

Note Always check the wiring before supplying power.

After soldering all of the necessary pins, slide the heat-shrinking tubes over the soldered areas of the respective wires. Then shrink the tubes by heating them with a jet of hot air.

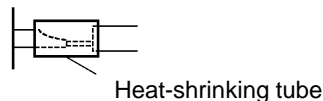

Assemble the socket and hood as shown in the illustration below. At the connector on the CQM1H side, wrap aluminum tape around the twisted wire as shown in the illustration, and secure the wire to the hood.

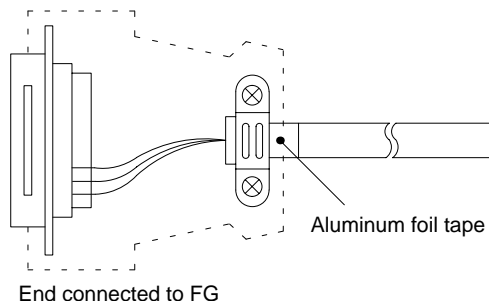

Glossary

*DM	Indirectly addressed DM area. See <i>indirect address</i> and <i>DM area</i> .
1:1 link	A link created between two PCs to create <i>common data</i> in their LR areas.
ACP	See <i>add count input</i> .
add count input	An input signal used to increment a counter when the signal changes from OFF to ON.
address	A number used to identify the location of data or programming instructions in memory.
AND	A logic operation whereby the result is true if and only if both premises are true. In ladder-diagram programming the premises are usually ON/OFF states of bits or the logical combination of such states called execution conditions.
area	See <i>data area</i> and <i>memory area</i> .
area prefix	A one or two letter prefix used to identify a memory area in the PC. All memory areas except the IR and SR areas require prefixes to identify addresses in them.
arithmetic shift	A shift operation wherein the carry flag is included in the shift.
ASCII	Short for American Standard Code for Information Interchange. ASCII is used to code characters for output to printers and other external devices.
AR Area	A PC data area allocated to flags and control bits.
AUTOEXEC.BAT	An MS DOS file containing commands automatically executed at startup.
back-up	A copy made of existing data to ensure that the data will not be lost even if the original data is corrupted or erased.
basic instruction	A fundamental instruction used in a ladder diagram.
baud rate	The data transmission speed between two devices in a system measured in bits per second.
BCD	See <i>binary-coded decimal</i> .
BCD calculation	An arithmetic calculation that uses numbers expressed in binary-coded decimal.
binary	A number system where all numbers are expressed in base 2, i.e., numbers are written using only 0's and 1's. Each group of four binary bits is equivalent to one hexadecimal digit. Binary data in memory is thus often expressed in hexadecimal for convenience.
binary calculation	An arithmetic calculation that uses numbers expressed in binary.
binary-coded decimal	A system used to represent numbers so that every four binary bits is numerically equivalent to one decimal digit.
bit	The smallest piece of information that can be represented on a computer. A bit has the value of either zero or one, corresponding to the electrical signals ON and OFF. A bit represents one binary digit. Some bits at particular addresses are allocated to special purposes, such as holding the status of input from external devices, while other bits are available for general use in programming.
bit address	The location in memory where a bit of data is stored. A bit address specifies the data area and word that is being addressed as well as the number of the bit within the word.

bit designator	An operand that is used to designate the bit or bits of a word to be used by an instruction.
bit number	A number that indicates the location of a bit within a word. Bit 00 is the rightmost (least-significant) bit; bit 15 is the leftmost (most-significant) bit.
bit-control instruction	An instruction that is used to control the status of an individual bit as opposed to the status of an entire word.
block	See <i>logic block</i> and <i>instruction block</i> .
building-block PC	A PC that is constructed from individual components, or “building blocks.” With building-block PCs, there is no one Unit that is independently identifiable as a PC. The PC is rather a functional assembly of Units.
bus	A communications path used to pass data between any of the Units connected to it.
bus bar	The line leading down the left and sometimes right side of a ladder diagram. Instruction execution proceeds down the bus bar, which is the starting point for all instruction lines.
byte	A unit of data equivalent to 8 bits, i.e., half a word.
call	A process by which instruction execution shifts from the main program to a subroutine. The subroutine may be called by an instruction or by an interrupt.
Carry Flag	A flag that is used with arithmetic operations to hold a carry from an addition or multiplication operation, or to indicate that the result is negative in a subtraction operation. The carry flag is also used with certain types of shift operations.
central processing unit	A device that is capable of storing programs and data, and executing the instructions contained in the programs. In a PC System, the central processing unit executes the program, processes I/O signals, communicates with external devices, etc.
CH	See <i>word</i> .
channel	See <i>word</i> .
character code	A numeric (usually binary) code used to represent an alphanumeric character.
checksum	A sum transmitted with a data pack in communications. The checksum can be recalculated from the received data to confirm that the data in the transmission has not been corrupted.
clock pulse	A pulse available at specific bits in memory for use in timing operations. Various clock pulses are available with different pulse widths, and therefore different frequencies.
clock pulse bit	A bit in memory that supplies a pulse that can be used to time operations. Various clock pulse bits are available with different pulse widths, and therefore different frequencies.
common data	Data that is stored in a memory of a PC and which is shared by other PCs in the same system. Each PC has a specified section(s) of the area allocated to it. Each PC writes to the section(s) allocated to it and reads the sections allocated to the other PCs with which it shares the common data.
communications cable	Cable used to transfer data between components of a control system and conforming to the RS-232C or RS-422 standards.
comparison instruction	An instruction used to compare data at different locations in memory to determine the relationship between the data.

Completion Flag	A flag used with a timer or counter that turns ON when the timer has timed out or the counter has reached its set value.
condition	A symbol placed on an instruction line to indicate an instruction that controls the execution condition for the terminal instruction. Each condition is assigned a bit in memory that determines its status. The status of the bit assigned to each condition determines the next execution condition. Conditions correspond to LOAD, LOAD NOT, AND, AND NOT, OR, or OR NOT instructions.
CONFIG.SYS	An MS DOS file containing environment settings for a personal computer.
constant	An input for an operand in which the actual numeric value is specified. Constants can be input for certain operands in place of memory area addresses. Some operands must be input as constants.
control bit	A bit in a memory area that is set either through the program or via a Programming Device to achieve a specific purpose, e.g., a Restart Bit is turned ON and OFF to restart a Unit.
control data	An operand that specifies how an instruction is to be executed. The control data may specify the part of a word is to be used as the operand, it may specify the destination for a data transfer instructions, it may specify the size of a data table used in an instruction, etc.
control signal	A signal sent from the PC to effect the operation of the controlled system.
Control System	All of the hardware and software components used to control other devices. A Control System includes the PC System, the PC programs, and all I/O devices that are used to control or obtain feedback from the controlled system.
controlled system	The devices that are being controlled by a PC System.
count pulse	The signal counted by a counter.
counter	A dedicated group of digits or words in memory used to count the number of times a specific process has occurred, or a location in memory accessed through a TIM/CNT bit and used to count the number of times the status of a bit or an execution condition has changed from OFF to ON.
CPU Unit	See <i>central processing unit</i> .
CTS	An acronym for clear-to-send, a signal used in communications between electronic devices to indicate that the receiver is ready to accept incoming data.
CX-Programmer	Windows-based Support Software for programming SYSMAC PCs.
CX-Protocol	Windows-based Support Software for the protocol macro function of SYSMAC PCs.
CY	See <i>Carry Flag</i> .
cycle	One unit of processing performed by the CPU Unit, including ladder program execution, peripheral servicing, I/O refreshing, etc.
cycle time	The time required to complete one cycle of CPU Unit processing.
cyclic interrupt	See <i>scheduled interrupt</i> .
data area	An area in the PC's memory that is designed to hold a specific type of data.
data area boundary	The highest address available within a data area. When designating an operand that requires multiple words, it is necessary to ensure that the highest address in the data area is not exceeded.

data disk	A floppy disk used to save user programs, DM area contents, comments, and other user data.
data length	In communications, the number of bits that is to be treated as one unit in data transmissions.
data link	An automatic data transmission operation that allows PCs or Units within PC to pass data back and forth via common data areas.
data link area	A common data area established through a data link.
data movement instruction	An instruction used to move data from one location in memory to another. The data in the original memory location is left unchanged.
data sharing	The process in which common data areas or common data words are created between two or more PCs.
data trace	A process in which changes in the contents of specific memory locations are recorded during program execution.
data transfer	Moving data from one memory location to another, either within the same device or between different devices connected via a communications line or network.
debug	A process by which a draft program is corrected until it operates as intended. Debugging includes both the removal of syntax errors, as well as the fine-tuning of timing and coordination of control operations.
decimal	A number system where numbers are expressed to the base 10. In a PC all data is ultimately stored in binary form, four binary bits are often used to represent one decimal digit, via a system called binary-coded decimal.
decrement	Decreasing a numeric value, usually by 1.
default	A value automatically set by the PC when the user does not specifically set another value. Many devices will assume such default conditions upon the application of power.
definer	A number used as an operand for an instruction but that serves to define the instruction itself, rather than the data on which the instruction is to operate. Definers include jump numbers, subroutine numbers, etc.
destination	The location where an instruction places the data on which it is operating, as opposed to the location from which data is taken for use in the instruction. The location from which data is taken is called the source.
differentiated instruction	An instruction that is executed only once each time its execution condition goes from OFF to ON. Non-differentiated instructions are executed for each scan as long as the execution condition stays ON.
differentiation instruction	An instruction used to ensure that the operand bit is never turned ON for more than one scan after the execution condition goes either from OFF to ON for a Differentiate Up instruction or from ON to OFF for a Differentiate Down instruction.
digit	A unit of storage in memory that consists of four bits.
digit designator	An operand that is used to designate the digit or digits of a word to be used by an instruction.
DIN track	A rail designed to fit into grooves on various devices to allow the devices to be quickly and easily mounted to it.
DIP switch	Dual in-line package switch, an array of pins in a single package that is mounted to a circuit board and is used to set operating parameters.

direct output	A method in which program execution results are output immediately to eliminate the affects of the cycle time.
distributed control	A automation concept in which control of each portion of an automated system is located near the devices actually being controlled, i.e., control is decentralized and 'distributed' over the system. Distributed control is a concept basic to PC Systems.
DM area	A data area used to hold only word data. Words in the DM area cannot be accessed bit by bit.
DM word	A word in the DM area.
downloading	The process of transferring a program or data from a higher-level or host computer to a lower-level or slave computer. If a Programming Device is involved, the Programming Device is considered the host computer.
EEPROM	Electrically erasable programmable read-only memory; a type of ROM in which stored data can be erased and reprogrammed. This is accomplished using a special control lead connected to the EEPROM chip and can be done without having to remove the EEPROM chip from the device in which it is mounted.
electrical noise	Random variations of one or more electrical characteristics such as voltage, current, and data, which might interfere with the normal operation of a device.
EPROM	Erasable programmable read-only memory; a type of ROM in which stored data can be erased, by ultraviolet light or other means, and reprogrammed.
error code	A numeric code generated to indicate that an error exists, and something about the nature of the error. Some error codes are generated by the system; others are defined in the program by the operator.
Error Log Area	An area used to store records indicating the time and nature of errors that have occurred in the system.
even parity	A communication setting that adjusts the number of ON bits so that it is always even. See <i>parity</i> .
event processing	Processing that is performed in response to an event, e.g., an interrupt signal.
exclusive NOR	A logic operation whereby the result is true if both of the premises are true or both of the premises are false. In ladder-diagram programming, the premises are usually the ON/OFF states of bits, or the logical combination of such states, called execution conditions.
exclusive OR	A logic operation whereby the result is true if one, and only one, of the premises is true. In ladder-diagram programming the premises are usually the ON/OFF states of bits, or the logical combination of such states, called execution conditions.
execution condition	The ON or OFF status under which an instruction is executed. The execution condition is determined by the logical combination of conditions on the same instruction line and up to the instruction currently being executed.
execution cycle	The cycle used to execute all processes required by the CPU Unit, including program execution, I/O refreshing, peripheral servicing, etc.
execution time	The time required for the CPU Unit to execute either an individual instruction or an entire program.
extended counter	A counter created in a program by using two or more count instructions in succession. Such a counter is capable of counting higher than any of the standard counters provided by the individual instructions.

extended timer	A timer created in a program by using two or more timers in succession. Such a timer is capable of timing longer than any of the standard timers provided by the individual instructions.
FA	Factory automation.
factory computer	A general-purpose computer, usually quite similar to a business computer, that is used in automated factory control.
FAL error	An error generated from the user program by execution of an FAL(06) instruction.
FALS error	An error generated from the user program by execution of an FALS(07) instruction or an error generated by the system.
fatal error	An error that stops PC operation and requires correction before operation can continue.
FCS	See <i>frame checksum</i> .
flag	A dedicated bit in memory that is set by the system to indicate some type of operating status. Some flags, such as the carry flag, can also be set by the operator or via the program.
flicker bit	A bit that is programmed to turn ON and OFF at a specific frequency.
floating-point decimal	A decimal number expressed as a number (the mantissa) multiplied by a power of 10, e.g., 0.538×10^{-5} .
force reset	The process of forcibly turning OFF a bit via a programming device. Bits are usually turned OFF as a result of program execution.
force set	The process of forcibly turning ON a bit via a programming device. Bits are usually turned ON as a result of program execution.
forced status	The status of bits that have been force reset or force set.
frame checksum	The results of exclusive ORing all data within a specified calculation range. The frame checksum can be calculated on both the sending and receiving end of a data transfer to confirm that data was transmitted correctly.
function code	A two-digit number used to input an instruction into the PC.
hardware error	An error originating in the hardware structure (electronic components) of the PC, as opposed to a software error, which originates in software (i.e., programs).
header code	A code in an instruction that specifies what the instruction is to do.
hexadecimal	A number system where all numbers are expressed to the base 16. In a PC all data is ultimately stored in binary form, however, displays and inputs on Programming Devices are often expressed in hexadecimal to simplify operation. Each group of four binary bits is numerically equivalent to one hexadecimal digit.
host computer	A computer that is used to transfer data to or receive data from a PC in a Host Link system. The host computer is used for data management and overall system control. Host computers are generally small personal or business computers.
host interface	An interface that allows communications with a host computer.
host link	An interface connecting a PC to a host computer to enable monitoring or program control from the host computer.
HR area	A memory area that preserves bit status during power interrupts and used as work bits in programming.

I/O bit	A bit in memory used to hold I/O status. Input bits reflect the status of input terminals; output bits hold the status for output terminals.
I/O capacity	The number of inputs and outputs that a PC is able to handle. This number ranges from around one hundred for smaller PCs to two thousand for the largest ones.
I/O delay	The delay in time from when a signal is sent to an output to when the status of the output is actually in effect, or the delay in time from when the status of an input changes until the signal indicating the change in the status is received.
I/O device	A device connected to the I/O terminals on I/O Units. I/O devices may be either part of the Control System, if they function to help control other devices, or they may be part of the controlled system.
I/O interrupt	An interrupt generated by a signal from I/O.
I/O point	The place at which an input signal enters the PC System, or at which an output signal leaves the PC System. In physical terms, I/O points correspond to terminals or connector pins on a Unit; in terms of programming, an I/O points correspond to I/O bits in the IR area.
I/O refreshing	The process of updating output status sent to external devices so that it agrees with the status of output bits held in memory, and of updating input bits in memory so that they agree with the status of inputs from external devices.
I/O response time	The time required for an output signal to be sent from the PC in response to an input signal received from an external device.
I/O Unit	The Units in a PC that are physically connected to I/O devices to input and output signals. I/O Units include Input Units and Output Units, each of which is available in a range of specifications.
I/O word	A word in the IR area that is allocated to a Unit in the PC System and is used to hold I/O status for that Unit.
IBM PC/AT or compatible	A computer that has similar architecture to, that is logically compatible with, and that can run software designed for an IBM PC/AT computer.
increment	Increasing a numeric value, usually by 1.
indirect address	An address whose contents indicates another address. The contents of the second address will be used as the actual operand.
initialization error	An error that occurs either in hardware or software during the PC System startup, i.e., during initialization.
initialize	Part of the startup process whereby some memory areas are cleared, system setup is checked, and default values are set.
input	The signal coming from an external device into the PC. The term input is often used abstractly or collectively to refer to incoming signals.
input bit	A bit in the IR area that is allocated to hold the status of an input.
input device	An external device that sends signals into the PC System.
input point	The point at which an input enters the PC System. Input points correspond physically to terminals or connector pins.
input signal	A change in the status of a connection entering the PC. Generally an input signal is said to exist when, for example, a connection point goes from low to high voltage or from a nonconductive to a conductive state.

instruction	A direction given in the program that tells the PC of the action to be carried out, and the data to be used in carrying out the action. Instructions can be used to simply turn a bit ON or OFF, or they can perform much more complex actions, such as converting and/or transferring large blocks of data.
instruction block	A group of instructions that is logically related in a ladder-diagram program. A logic block includes all of the instruction lines that interconnect with each other from one or more lines connecting to the left bus bar to one or more right-hand instructions connecting to the right bus bar.
instruction execution time	The time required to execute an instruction. The execution time for any one instruction can vary with the execution conditions for the instruction and the operands used in it.
instruction line	A group of conditions that lie together on the same horizontal line of a ladder diagram. Instruction lines can branch apart or join together to form instruction blocks. Also called a rung.
interface	An interface is the conceptual boundary between systems or devices and usually involves changes in the way the communicated data is represented. Interface devices perform operations like changing the coding, format, or speed of the data.
interlock	A programming method used to treat a number of instructions as a group so that the entire group can be reset together when individual execution is not required. An interlocked program section is executed normally for an ON execution condition and partially reset for an OFF execution condition.
interrupt (signal)	A signal that stops normal program execution and causes a subroutine to be run or other processing to take place.
interrupt program	A program that is executed in response to an interrupt.
inverse condition	See <i>normally closed condition</i> .
JIS	An acronym for Japanese Industrial Standards.
jump	A type of programming where execution moves directly from one point in a program to another, without sequentially executing any instructions in between.
jump number	A definer used with a jump that defines the points from and to which a jump is to be made.
ladder diagram (program)	A form of program arising out of relay-based control systems that uses circuit-type diagrams to represent the logic flow of programming instructions. The appearance of the program is similar to a ladder, and thus the name.
ladder diagram symbol	A symbol used in drawing a ladder-diagram program.
ladder instruction	An instruction that represents the conditions on a ladder-diagram program. The other instructions in a ladder diagram fall along the right side of the diagram and are called terminal instructions.
least-significant (bit/word)	See <i>rightmost (bit/word)</i> .
LED	Acronym for light-emitting diode; a device used for indicators or displays.
leftmost (bit/word)	The highest numbered bits of a group of bits, generally of an entire word, or the highest numbered words of a group of words. These bits/words are often called most-significant bits/words.
link	A hardware or software connection formed between two Units. "Link" can refer either to a part of the physical connection between two Units or a software connection created to data existing at another location (i.e., data links).

load	The processes of copying data either from an external device or from a storage area to an active portion of the system such as a display buffer. Also, an output device connected to the PC is called a load.
logic block	A group of instructions that is logically related in a ladder-diagram program and that requires logic block instructions to relate it to other instructions or logic blocks.
logic block instruction	An instruction used to locally combine the execution condition resulting from a logic block with a current execution condition. The current execution condition could be the result of a single condition, or of another logic block. AND Load and OR Load are the two logic block instructions.
logic instruction	Instructions used to logically combine the content of two words and output the logical results to a specified result word. The logic instructions combine all the same-numbered bits in the two words and output the result to the bit of the same number in the specified result word.
LR area	A data area that is used in data links.
main program	All of a program except for subroutine and interrupt programs.
mark trace	A process in which changes in the contents of specific memory locations are recorded during program execution.
masked bit	A bit whose status has been temporarily made ineffective.
masking	'Covering' an interrupt signal so that the interrupt is not effective until the mask is removed.
megabyte	A unit of storage equal to one million bytes.
memory area	Any of the areas in the PC used to hold data or programs.
message number	A number assigned to a message generated with the MESSAGE instruction.
mnemonic code	A form of a ladder-diagram program that consists of a sequential list of the instructions without using a ladder diagram.
MONITOR mode	A mode of PC operation in which normal program execution is possible, and which allows modification of data held in memory. Used for monitoring or debugging the PC.
most-significant (bit/word)	See <i>leftmost (bit/word)</i> .
NC input	An input that is normally closed, i.e., the input signal is considered to be present when the circuit connected to the input opens.
negative delay	A delay set for a data trace in which recording data begins before the trace signal by a specified amount.
nesting	Programming one loop within another loop, programming a call to a subroutine within another subroutine, or programming one jump within another.
NO input	An input that is normally open, i.e., the input signal is considered to be present when the circuit connected to the input closes.
noise interference	Disturbances in signals caused by electrical noise.
nonfatal error	A hardware or software error that produces a warning but does not stop the PC from operating.
normal condition	See <i>normally open condition</i> .

normally closed condition	A condition that produces an ON execution condition when the bit assigned to it is OFF, and an OFF execution condition when the bit assigned to it is ON.
normally open condition	A condition that produces an ON execution condition when the bit assigned to it is ON, and an OFF execution condition when the bit assigned to it is OFF.
NOT	A logic operation which inverts the status of the operand. For example, AND NOT indicates an AND operation with the opposite of the actual status of the operand bit.
OFF	The status of an input or output when a signal is said not to be present. The OFF state is generally represented by a low voltage or by non-conductivity, but can be defined as the opposite of either.
OFF delay	The delay between the time when a signal is switched OFF (e.g., by an input device or PC) and the time when the signal reaches a state readable as an OFF signal (i.e., as no signal) by a receiving party (e.g., output device or PC).
offset	A positive or negative value added to a base value such as an address to specify a desired value.
ON	The status of an input or output when a signal is said to be present. The ON state is generally represented by a high voltage or by conductivity, but can be defined as the opposite of either.
ON delay	The delay between the time when an ON signal is initiated (e.g., by an input device or PC) and the time when the signal reaches a state readable as an ON signal by a receiving party (e.g., output device or PC).
one-shot bit	A bit that is turned ON or OFF for a specified interval of time which is longer than one scan.
one-to-one link	See <i>1:1 link</i> .
online edit	The process of changing the program directly in the PC from a Programming Device. Online editing is possible in PROGRAM or MONITOR mode. In MONITOR mode, the program can actually be changed while it is being executed.
operand	The values designated as the data to be used for an instruction. An operand can be input as a constant expressing the actual numeric value to be used or as an address to express the location in memory of the data to be used.
operand bit	A bit designated as an operand for an instruction.
operand word	A word designated as an operand for an instruction.
operating modes	One of three PC modes: <i>PROGRAM mode</i> , <i>MONITOR mode</i> , and <i>RUN mode</i> .
operating error	An error that occurs during actual PC operation as opposed to an initialization error, which occurs before actual operations can begin.
OR	A logic operation whereby the result is true if either of two premises is true, or if both are true. In ladder-diagram programming the premises are usually ON/OFF states of bits or the logical combination of such states called execution conditions.
output	The signal sent from the PC to an external device. The term output is often used abstractly or collectively to refer to outgoing signals.
output bit	A bit in the IR area that is allocated to hold the status to be sent to an output device.
output device	An external device that receives signals from the PC System.

output point	The point at which an output leaves the PC System. Output points correspond physically to terminals or connector pins.
output signal	A signal being sent to an external device. Generally an output signal is said to exist when, for example, a connection point goes from low to high voltage or from a nonconductive to a conductive state.
overflow	The state where the capacity of a data storage location has been exceeded.
overseeing	Part of the processing performed by the CPU Unit that includes general tasks required to operate the PC.
overwrite	Changing the content of a memory location so that the previous content is lost.
parity	Adjustment of the number of ON bits in a word or other unit of data so that the total is always an even number or always an odd number. Parity is generally used to check the accuracy of data after being transmitted by confirming that the number of ON bits is still even or still odd.
parity check	Checking parity to ensure that transmitted data has not been corrupted.
PC	See <i>Programmable Controller</i> .
PC configuration	The arrangement and interconnections of the Units that are put together to form a functional PC.
PC System	With building-block PCs, all of the Units connected up to, but not including, the I/O devices. The boundaries of a PC System are the PC and the program in its CPU Unit at the upper end; and the I/O Units at the lower end.
PCB	See <i>printed circuit board</i> .
PC Setup	A group of operating parameters set in the PC from a Programming Device to control PC operation.
Peripheral Device	Devices connected to a PC System to aid in system operation. Peripheral devices include printers, programming devices, external storage media, etc.
peripheral servicing	Processing signals to and from peripheral devices, including refreshing, communications processing, interrupts, etc.
port	A connector on a PC or computer that serves as a connection to an external device.
positive delay	A delay set for a data trace in which recording data begins after the trace signal by a specified amount.
Power Supply Unit	A Unit that connected to a PC that provides power at the voltage required by the other Units.
present value	The current value registered in a device at any instant during its operation. Present value is abbreviated as PV. The use of this term is generally restricted to timers and counters.
printed circuit board	A board onto which electrical circuits are printed for mounting into a computer or electrical device.
PROGRAM mode	A mode of operation that allows inputting and debugging of programs to be carried out, but that does not permit normal execution of the program.
Programmable Controller	A computerized device that can accept inputs from external devices and generate outputs to external devices according to a program held in memory. Programmable Controllers are used to automate control of external devices.

	Although single-unit Programmable Controllers are available, building-block Programmable Controllers are constructed from separate components. Such Programmable Controllers are formed only when enough of these separate components are assembled to form a functional assembly.
programmed alarm	An alarm given as a result of execution of an instruction designed to generate the alarm in the program, as opposed to one generated by the system.
programmed error	An error arising as a result of the execution of an instruction designed to generate the error in the program, as opposed to one generated by the system.
programmed message	A message generated as a result of execution of an instruction designed to generate the message in the program, as opposed to one generated by the system.
Programming Console	The portable form of Programming Device for a PC.
Programming Device	A Peripheral Device used to input a program into a PC or to alter or monitor a program already held in the PC. There are dedicated programming devices, such as Programming Consoles, and there are non-dedicated devices, such as a host computer.
PROM	Programmable read-only memory; a type of ROM into which the program or data may be written after manufacture, by a customer, but which is fixed from that time on.
prompt	A message or symbol that appears on a display to request input from the operator.
protocol	The parameters and procedures that are standardized to enable two devices to communicate or to enable a programmer or operator to communicate with a device.
PV	See <i>present value</i> .
RAM	Random access memory; a data storage media. RAM will not retain data when power is disconnected.
RAS	An acronym for reliability, assurance, safety.
read-only area	A memory area from which the user can read status but to which data cannot be written.
refresh	The process of updating output status sent to external devices so that it agrees with the status of output bits held in memory, and of updating input bits in memory so that they agree with the status of inputs from external devices.
relay-based control	The forerunner of PCs. In relay-based control, groups of relays are interconnected to form control circuits. In a PC, these are replaced by programmable circuits.
reserved bit	A bit that is not available for user application.
reserved word	A word in memory that is reserved for a special purpose and cannot be accessed by the user.
reset	The process of turning a bit or signal OFF or of changing the present value of a timer or counter to its set value or to zero.
response code	A code sent with the response to a data transmission that specifies how the transmitted data was processed.
response format	A format specifying the data required in a response to a data transmission.
response monitoring time	The time a device will wait for a response to a data transmission before assuming that an error has occurred.

Restart Bit	A bit used to restart part of a PC.
result word	A word used to hold the results from the execution of an instruction.
retrieve	The processes of copying data either from an external device or from a storage area to an active portion of the system such as a display buffer. Also, an output device connected to the PC is called a load.
retry	The process whereby a device will re-transmit data which has resulted in an error message from the receiving device.
return	The process by which instruction execution shifts from a subroutine back to the main program (usually the point from which the subroutine was called).
reversible counter	A counter that can be both incremented and decremented depending on the specified conditions.
reversible shift register	A shift register that can shift data in either direction depending on the specified conditions.
right-hand instruction	See <i>terminal instruction</i> .
rightmost (bit/word)	The lowest numbered bit of a group of bits, generally of an entire word, or the lowest numbered word of a group of words. This bit/word is often called the least-significant bit/word.
rising edge	The point where a signal actually changes from an OFF to an ON status.
ROM	Read only memory; a type of digital storage that cannot be written to. A ROM chip is manufactured with its program or data already stored in it and can never be changed. However, the program or data can be read as many times as desired.
rotate register	A shift register in which the data moved out from one end is placed back into the shift register at the other end.
RS-232C interface	An industry standard for serial communications.
RUN mode	The operating mode used by the PC for normal control operations.
rung	See <i>instruction line</i> .
scan	The process used to execute a ladder-diagram program. The program is examined sequentially from start to finish and each instruction is executed in turn based on execution conditions.
scan time	See <i>cycle time</i> .
scheduled interrupt	An interrupt that is automatically generated by the system at a specific time or program location specified by the operator. Scheduled interrupts result in the execution of specific subroutines that can be used for instructions that must be executed repeatedly at a specified interval of time.
SCP	See <i>subtract count input</i> .
seal	See <i>self-maintaining bit</i> .
self diagnosis	A process whereby the system checks its own operation and generates a warning or error if an abnormality is discovered.
self-maintaining bit	A bit that is programmed to maintain either an OFF or ON status until set or reset by specified conditions.
series	A wiring method in which Units are wired consecutively in a string.

servicing	The process whereby the PC checks a connector or Unit to see if special processing is required.
set	The process of turning a bit or signal ON.
set value	The value from which a decrementing counter starts counting down or to which an incrementing counter counts up (i.e., the maximum count), or the time from which or for which a timer starts timing. Set value is abbreviated SV.
shift input signal	An input signal whose OFF to ON transition causes data to be shifted one bit.
shift register	One or more words in which data is shifted a specified number of units to the right or left in bit, digit, or word units. In a rotate register, data shifted out one end is shifted back into the other end. In other shift registers, new data (either specified data, zero(s) or one(s)) is shifted into one end and the data shifted out at the other end is lost.
signed binary	A binary value that is stored in memory along with a bit that indicates whether the value is positive or negative.
software error	An error that originates in a software program.
software protect	A means of protecting data from being changed that uses software as opposed to a physical switch or other hardware setting.
source (word)	The location from which data is taken for use in an instruction, as opposed to the location to which the result of an instruction is to be written. The latter is called the destination.
special instruction	An instruction input with a function code that handles data processing operations within ladder diagrams, as opposed to a basic instruction, which makes up the fundamental portion of a ladder diagram.
SR area	A memory area containing flags and other bits/words with specific functions.
SSS	See <i>SYSMAC Support Software</i> .
store	The process of recording a program written into a display buffer permanently in memory.
subroutine	A group of instructions placed separate from the main program and executed only when called from the main program or activated by an interrupt.
subroutine number	A definer used to identify the subroutine that a subroutine call or interrupt activates.
subtract count input	An input signal used to decrement a counter when the signal changes from OFF to ON.
SV	See <i>set value</i> .
switching capacity	The maximum voltage/current that a relay can safely switch on and off.
synchronous execution	Execution of programs and servicing operations in which program execution and servicing are synchronized so that all servicing operations are executed each time the programs are executed.
syntax	The form of a program statement (as opposed to its meaning).
syntax error	An error in the way in which a program is written. Syntax errors can include 'spelling' mistakes (i.e., a function code that does not exist), mistakes in specifying operands within acceptable parameters (e.g., specifying read-only bits as a destination), and mistakes in actual application of instructions (e.g., a call to a subroutine that does not exist).

SYSMAC Support Software	A software package installed on a IBM PC/AT or compatible computer to function as a Programming Device.
system configuration	The arrangement in which Units in a System are connected. This term refers to the conceptual arrangement and wiring together of all the devices needed to comprise the System.
system error	An error generated by the system, as opposed to one resulting from execution of an instruction designed to generate an error.
system error message	An error message generated by the system, as opposed to one resulting from execution of an instruction designed to generate a message.
terminal instruction	An instruction placed on the right side of a ladder diagram that uses the final execution conditions of an instruction line.
timer	A location in memory accessed through a TIM/CNT bit and used to time down from the timer's set value. Timers are turned ON and reset according to their execution conditions.
TR area	A data area used to store execution conditions so that they can be reloaded later for use with other instructions.
TR bit	A bit in the TR area.
trace	An operation whereby the program is executed and the resulting data is stored to enable step-by-step analysis and debugging.
trace memory	A memory area used to store the results of trace operations.
transfer	The process of moving data from one location to another within the PC, or between the PC and external devices. When data is transferred, generally a copy of the data is sent to the destination, i.e., the content of the source of the transfer is not changed.
transmission distance	The distance that a signal can be transmitted.
trigger	A signal used to activate some process, e.g., the execution of a trace operation.
trigger address	An address in the program that defines the beginning point for tracing. The actual beginning point can be altered from the trigger by defining either a positive or negative delay.
UM area	The memory area used to hold the active program, i.e., the program that is being currently executed.
Unit	In OMRON PC terminology, the word Unit is capitalized to indicate any product sold for a PC System. Most of the names of these products end with the word Unit.
unit number	A number assigned to some Units to facilitate identification when assigning words or other operating parameters.
unmasked bit	A bit whose status is effective. See <i>masked bit</i> .
unsigned binary	A binary value that is stored in memory without any indication of whether it is positive or negative.
uploading	The process of transferring a program or data from a lower-level or slave computer to a higher-level or host computer. If a Programming Devices is involved, the Programming Device is considered the host computer.
watchdog timer	A timer within the system that ensures that the scan time stays within specified limits. When limits are reached, either warnings are given or PC operation is stopped depending on the particular limit that is reached.

WDT	See <i>watchdog timer</i> .
word	A unit of data storage in memory that consists of 16 bits. All data areas consists of words. Some data areas can be accessed only by words; others, by either words or bits.
word address	The location in memory where a word of data is stored. A word address must specify (sometimes by default) the data area and the number of the word that is being addressed.
work area	A part of memory containing work words/bits.
work bit	A bit in a work word.
work word	A word that can be used for data calculation or other manipulation in programming, i.e., a 'work space' in memory. A large portion of the IR area is always reserved for work words. Parts of other areas not required for special purposes may also be used as work words.
write protect switch	A switch used to write-protect the contents of a storage device, e.g., a floppy disk. If the hole on the upper left of a floppy disk is open, the information on this floppy disk cannot be altered.
write-protect	A state in which the contents of a storage device can be read but cannot be altered.

Index

Numbers

1:1 Data Link,
1:1 NT Link,
1:N NT Link,

A–B

AC Input Units, specifications,
applications, precautions,
ASCII, converting displays, Programming Console,
battery, service life,
Battery Set, replacement,
binary data, modifying, Programming Console,
bit status, force-set/reset, Programming Console,
bits, searching, Programming Console,
buzzer operation, Programming Console,

C

C200H–PRO27–E Programming Console,
cabinet, Programming Console installation,
cables,
checking, program syntax, Programming Console,
clearing, memory areas, Programming Console,
clock, reading and setting the clock,
CompoBus/S,
CompoWay/F,
Contact Output Units, specifications,
counters
 changing SV, Programming Console,
 example of inputting,
CPU Unit
 dimensions,
 internal structure,
 specifications,
 weight,
CQM1H–PRO01–E Programming Console,
current consumption,
cycle time, displaying, Programming Console,

D

data, modifying, Programming Console, , , ,
DC Input Units, specifications,
decimal data with sign. *See* signed decimal data
decimal data without sign. *See* unsigned decimal data
differentiated instructions, entering,
dimensions
 CPU Unit,
 End Plate,
 I/O Units,
DIP switch, settings,
displays
 converting between hex and ASCII, Programming Console,
 cycle time, Programming Console,

E

EC Directives,
EEPROM ICs. *See* Memory Cassettes
electrical noise,
EMC,
emergency stop circuit,
End Cover, dimensions,
errors, reading/clearing messages, Programming Console,
expansion instructions, reading and changing function code
 assignments,

F–G

fail–safe circuits,
flicker output, example,
force-set/reset
 clearing, Programming Console,
 Programming Console,
function codes, reading and changing expansion instruction
 assignments,
ground, precautions, ,

H

hexadecimal data, converting displays, Programming Console,

High-speed Counter Board,
configuration,
connectors,
count modes,
external outputs,
functions, ,
installation,
pulse inputs,
specifications,
counters, ,
external outputs,
inputs,

Host Link,

Host Link System,

I

I/O memory,
initializing,

I/O Unit
components,
types,

I/O Units
dimensions,
models,
terminal block removal,
weight,

inductive load surge suppressor,

initialization, I/O memory,

input devices, wiring,

inrush current,

installation
DIN Track,
fail-safe circuits,
precautions,

instructions
inserting and deleting, Programming Console,
searching, Programming Console,

J–M

Japanese messages, change to English,

leakage current, input,

maintenance, battery replacement,

memory. *See* I/O memory; user memory

memory areas
clearing, Programming Console,
partial clear, ,

Memory Cassettes, required EEPROMs,

messages, reading/clearing,

mode, changing the PC mode,

modifying
binary data, Programming Console,
data, Programming Console,
hexadecimal/BCD data, Programming Console,
signed decimal data, Programming Console,
SV, Programming Console,
unsigned decimal data, Programming Console,

MONITOR mode

description, ,
example test run,

monitoring

3-word monitor, Programming Console,
binary monitor, Programming Console,
differentiation monitor, Programming Console,
signed decimal monitor, Programming Console,
status, Programming Console, ,
unsigned decimal monitor, Programming Console,

N–P

no-protocol communications,

NT Links,

operating environment, precautions,

operating modes
description,
operating mode at startup,

operation, preparations,

panel, Programming Console installation,

password, entering on Programming Console,

PC mode, changing,

PC Setup,

peripheral port, connecting devices,

power supply, wiring, precautions,

Power Supply Units
components,
dimensions,
emergency stop,
specifications,

precautions,
applications,
general,
ground, ,
interlock circuits,
operating environment,
safety,
safety circuits,

program, programming example,

program memory, setting address and reading content, Programming Console,

PROGRAM mode, description, ,

programming,
checking the program,
checks for syntax, Programming Console,

inserting and deleting instructions, Programming Console,
preparation for,
searching, Programming Console,
setting and reading a memory address, Programming Console,

Programming Console

connecting, ,
keys,
models,
operations,
using,

Programming Consoles,

Programming Devices,

programming example,

programs, entering and editing, Programming Console,

protocol macros, ,

Pulse I/O Board,

configuration,
count modes,
indicators
 pulse inputs,
 pulse outputs,
installation,
interrupts,
pulse input indicators,
pulse output indicators,

R–S

remote I/O communications, CompoBus/S,

RS-232C

communications, one-to-one link,
connecting Units,

RS-232C port, specifications,

RUN mode, description, ,

safety circuits,

safety precautions. *See* precautions

search

instruction, Programming Console,
operands, Programming Console,

self-holding bit, example,

Serial Communications Boards,

serial communications modes

1:1 Data Link,
1:1 NT Link,
1:N NT Link,
Host Link,
no-protocol,
protocol macro,

signed decimal data

 modifying, Programming Console,
 monitoring,

specifications

AC Input Units,
Contact Output Units,
CPU Unit,
CPU Unit inputs,
DC Input Units,
functions,
Power Supply Units,
Units,

status, monitoring, Programming Console, ,

SV, modifying, Programming Console,

syntax, checking the program, Programming Console,

SYSMAC WAY. *See* Host Link

system configuration

Host Link,
NT Link,

T–W

test run, example,

timers

 changing SV, Programming Console,
 example of inputting,

Transistor Output Unit, specifications,

unsigned decimal data

 modifying, Programming Console,
 monitoring,

wiring

AC Power Supply Units,
DC Power Supply Units,
I/O Units,
precautions, interlock circuits,

Revision History

A manual revision code appears as a suffix to the catalog number on the front cover of the manual.

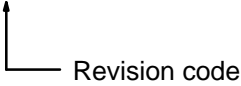
Cat. No. W363-E1-2
 Revision code

The following table outlines the changes made to the manual during each revision. Page numbers refer to the previous version.

Revision code	Date	Revised content
1	September 1999	Original production
2	May 2000	<p>Modifications for the addition of an Expansion I/O Block as follows:</p> <p>Page xvi: "Expansion cable" changed to "Expansion I/O Cable."</p> <p>Page 2: Processing speeds changed at bottom of page.</p> <p>Pages 2, 6, 7, 8, 9, 10, 15, 23, 32, 41, 83, 84, 86, 100, 102, 104, 105, 110, : Information on Expansion I/O Block added.</p> <p>Page 9: Table added on clock accuracy.</p> <p>Pages 15, 35, and 88 : Added information on Temperature Control Units.</p> <p>Page 40: Noise immunity specification changed.</p> <p>Pages 59, 62, 65, and 67: Note added to <i>Terminal Connections</i>.</p> <p>Pages 61, 68, 210: Circuit configuration corrected.</p> <p>Pages 75 and 77: Information added on write life expectancy.</p> <p>Page 93: Information added for Link Adapter cables.</p> <p>Page 110 : Dimensions corrected.</p> <p>Page 128: Note added under table.</p> <p>Page 181 : Function codes for JMP and JME corrected.</p> <p>Page 204: Note added and last sentence on page corrected.</p> <p>Page 206: Graphic corrected.</p> <p>Page 207: Table corrected.</p> <p>Page 209: Words deleted from <i>Analog input storage words</i> specification.</p>



OMRON

Authorized Distributor:

