

User's Manual For

**PRAXSYM**

**PAMS**

Portable Attenuation Measurement System



[www.praxsym.com](http://www.praxsym.com) 217/897-1744



## Contents

I.	Introduction .....	3
1.0	General Information.....	4
1.1	Equipment Purpose.....	4
1.2	Equipment List .....	4
1.3	Specifications.....	4
2.0	Installation .....	7
2.1	Recharging PAMS Units .....	7
2.2	Safety/Handling .....	7
3.0	Operation.....	8
3.2.0	“SEAM-SNIFFING” OPERATIONAL SEQUENCE .....	8
3.2.1	TRANS – Initial Setup and Power-On .....	8
3.2.2	TRANS – Frequency Set.....	8
3.2.3	RCVR – Initial Setup and Power-On .....	9
3.2.4	RCVR – Set Receiver Frequency = Xmit Frequency .....	9
3.2.5	RCVR – Perform Cal .....	10
3.2.6	TRANS – Set Atten to Operate Level.....	10
3.2.7	RCVR – Verify Post-Calibration Level.....	11
3.2.8	SHIELDED ROOM – Close Enclosure Door .....	11
3.2.9	RCVR – Read Shielding Level.....	11
3.2.10	RCVR – Audio Threshold/Tone Usage .....	12
3.3.0	“MONITOR (TS-31) MODE” OPERATIONAL SEQUENCE .....	13
3.3.1	TRANS – Setup and Power-On .....	13
3.3.2	TRANS – Frequency Set.....	13
3.3.3	RCVR – Calibration Set-Up .....	14
3.3.4	RCVR – Set Receiver Frequency = Xmit Frequency .....	14
3.3.5	RCVR – Perform Calibration.....	15
3.3.6	TRANS – Attach Ant, Set Atten to Operate Lev .....	15
3.3.7	SHIELDED ROOM – Close Door.....	16
3.3.8	RCVR – Operat. Set up, Monitor Ant. 1-12 .....	16
3.3.9	RCVR – Monitor Measurement, Antennas 1-12 .....	16
3.3.10	RCVR – Audio Threshold/Tone Usage .....	17
3.4.0	“BROADBAND MODE” SNIFFING OPERATIONAL SEQUENCE.....	17
3.4.1	TRANS – Setup and Power-On .....	17
3.4.2	SPECTRUM ANALYZER – Sniffing Measurements .....	18
4.0	Test and Inspection .....	19
4.2.1	TRANS – Setup and Power-On .....	19
4.2.2	TRANS – Frequency Set to 904.2 MHz .....	19
4.2.3	RCVR – Setup and Power-On .....	19
4.2.4	RCVR – Set RCVR Freq equal to XMIT Freq.....	19
4.2.5	RCVR – Perform Cal .....	19
4.2.6	TRANS – Set Atten to Operate Level.....	19
4.2.7	RCVR – Read Post-Calibration Level .....	19
4.2.8	TRANS – Set Atten to Operate Level.....	19
4.2.9	RCVR – Read Operation Level.....	19

## Introduction

The Portable Attenuation Measurement System (PAMS) is designed to measure the shielding effectiveness of RF enclosures. The operational concept of PAMS is based upon the measurement methodology outlined in MIL-STD-285.

Chapter 1.0 (General Information) provides:

- ✓ The overall function and purpose of the equipment
- ✓ A listing of included equipment
- ✓ Specifications

Chapter 2 (Installation) describes site selection, unpacking and handling, power requirements, safety procedures, preparation for reshipment and a listing of recommended accessories.

Chapter 3 (Operation) describes operational sequences necessary to perform required certification and verification.

Chapter 4 (Test and Inspection) describes tests, which may be conducted to verify correct system operation.

**PAMS**  
**User's Manual**

**1.0 General Information**

**1.1 Equipment Purpose**

The Portable Attenuation Measurement System (PAMS) measures the shielding effectiveness of RF enclosures. Both bar graph and numeric readout display the shielding level (dB).

**1.2 Equipment List**

- ✓ Transmitter
- ✓ Receiver
- ✓ Rechargeable Battery Packs (2 each, one installed per unit,) 9.6 V
- ✓ Battery Chargers (2 each) / AC/DC Adapter
- ✓ 32 ohm (Walkman type) headphone set
- ✓ 12 position coax switch
- ✓ 6' BNC/BNC RF (50 ohm) cable (for use in MONITOR mode)
- ✓ Antennas (2 each), extended  $\frac{1}{4}$  wavelength
- ✓ Transit case
- ✓ User's manual

**1.3 Specifications**

Specifications for the PAMS transmitter and receiver are tabulated in Figures 1-1 and 1-2. Overall systems specifications are presented in Figure 1-3.

Figure 1-1

**PAMS Receiver Specifications**

Frequency	864-936 MHz
Detection Mode(s)	CW
Measurement Range	0dBm to -120dBm
Stability	+/- 2.5 ppm
Charger at power jack	AC, 95-250 VAC, 47-63 Hz DC, 15V +/-1.0V
Battery Operation	4 hours operation 90 minutes recharge
Controls	OFF/VOL, MODE, CAL, FREQ, TUNE, T'HOLD, LOCK, LIGHT
Indicators	BATTERY LEVEL, SIGNAL LEVEL, THRESHOLD SETTING, MODE, LOCK, CAL STATUS, FREQ, FREQ ADJ
Headphone Imped.	32 ohms
Weight	5.5 lbs.
Size	11.7" H x 5.1"D x 4.9"W

Figure 1-2

**PAMS Transmitter Specifications**

Frequency	864-936 MHz
Output Power	1 watt (CW mode) -12 dBm (Broadband mode)
Operating Modes	CW, Comblin (750-1000 MHz) 25 MHz steps
Attenuation	0 to 60 dB in 1 dB steps
Stability	+/-2.5 ppm
Charger at power jack	AC, 95-250 VAC, 47-63 Hz DC, 15V +/-1.0V
Battery Operation	2 hours operation 90 minutes recharge

Controls	OFF/ON, MODE, ATTEN, FREQ, TUNE, LOCK, LIGHT
Indicators	BATTERY LEVEL, OUTPUT POWER, MODE, LOCK, ATTEN LEVEL, FREQ
Weight	5.5 lbs.
Size	11.7" H x 5.1"D x 4.9"W

Figure 1-3

**PAMS Overall System Specifications**

End-to-End: Dynamic Range	140 dB <sup>1</sup>
Meas. Accuracy	+/- 2 dB (-110 to 0 dBm)
Channel Spacing	100kHz
Operating Temperature	0°C to 40°C
User Interface	Full Alpha-numeric Backlit LCD Display

---

<sup>1</sup> Dynamic range is defined as the ratio (in dB) of maximum transmit power to receiver noise floor.

## 2.0 **Installation**

The PAMS is normally shipped (and transported) in a shock resistant transit case. Batteries for the transmitter and receiver are already contained inside the respective units.

### 2.1 **Recharging the PAMS Units**

Remove the battery chargers from the transit case. Plug the recharge jack into the recharge receptacle on the right side of the PAMS Transmitter (or Receiver). Plug the charger line cord into an AC source (95-250 VAC, 47-63 Hz). The green CHARGE light on the front face of the PAMS unit should illuminate. When the unit is fully charged, the CHARGE light should begin flashing.

When the units are fully charged, remove the charging jack from the PAMS unit. Unplug the chargers and the receptacle line cords from the AC supply and return them to the transit case.

If it becomes necessary to remove or replace the NiCad battery pack:

- ✓ locate the bottom face of the unit, which houses the battery compartment cover
- ✓ remove 4 socket head screws from battery cover bumper
- ✓ remove the 4 Phillips head screws from the battery cover
- ✓ remove the battery cover and disconnect the 2 pin connector
- ✓ slide the battery out of the compartment

### 2.2 **Safety/Handling**

The PAMS system has been designed to survive in-field usage, however the following handling restrictions should be observed:

- ✓ Do not drop the units.
- ✓ Protect the units from electrostatic discharge.
- ✓ Do not connect high power (>1W) RF sources to the BNC connectors.
- ✓ Do not connect DC sources to the BNC connectors.

### 3.0 Operation

This section describes the actions necessary to operate the PAMS in the SNIFF or MONITOR mode. Within the text, TRANS refers to the PAMS Transmitter, while RCVR refers to the PAMS Receiver.

#### 3.2.0 SEAM-SNIFFING OPERATIONAL SEQUENCE

##### 3.2.1 TRANS - Initial Setup and Power-On

- ✓ Attach one of the antennas to the BNC jack located on the top face of the transmitter.
- ✓ Open enclosure door. Place the PAMS Transmitter inside the enclosure on a marked reference position.
- ✓ Power-On / Rotate POWER switch to ON position and allow a 5 minute warm-up period.
- ✓ Confirm that the output power is set to  $-30$  dBm. Depressing the "Attn" switch sets output power. Each time the Attn switch is depressed, output attenuation will toggle between 0dB and 60dB. Once 60 dB of attenuation has been added, depressing the switch again will set the output attenuator to 0 dBm. Switching to the Power Adjust mode allows users to select attenuation levels in 1dB steps.

900.0 MHz FREQ	Low	Chg	
	-----		BATT
=			
-30	-10	+10	+30
POWER OUT: -30 dBm			
MODE:	cw		
ATTEN:	60 dB		
LOCK:	off		
FRQ ADJ:	1MHz		

TRANSMITTER INITIAL STATE  
ON POWER UP

OUTPUT ATTENUATION

##### 3.2.2 TRANS - Frequency Set

- ✓ Adjust rotary LOW/HIGH (1 MHz steps) FREQ control
- ✓ Depress F. DIGIT switch, FR ADJ toggles to "100kHz".
- ✓ Set rotary LOW/HIGH (100 kHz steps) FREQ control

879.4 MHz FREQ	Low	Chg	
	-----		BATT
=			
-30	-10	+10	+30
POWER LEVEL (dBm)			
MODE:	cw		
ATTEN:	60 dB		
LOCK:	off		
FRQ ADJ:	100kHz		

TRANSMITTER FREQUENCY  
SET

TRANSMIT FREQUENCY



### 3.2.3 RVCR – Initial Setup and Power-On

- ✓ Attach one of the antennas to the BNC jack located on the top face of the receiver.
- ✓ Locate the receiver outside the enclosure on a marked reference position, at least four feet from the transmitter. Make sure that the receiver reference position is within view of the PAMS transmitter.
- ✓ Power-On / Rotate POWER switch to ON position.
- ✓ Confirm that the receiver is set to SNIFF mode. Depress the mode switch to rotate through the receiver modes.

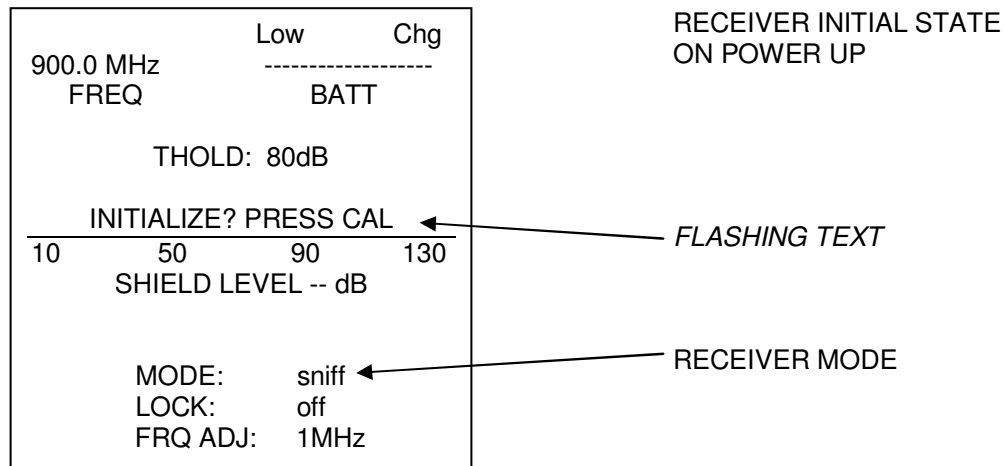

### 3.2.4 RCVR – Set Receiver Freq = Xmit Freq

- ✓ Adjust rotary LOW/HIGH (coarse) FREQUENCY control (1 MHz steps)
  - ✓ Depress F. DIGIT switch, the FR ADJ status toggles to “100kHz”.
  - ✓ Adjust rotary LOW/HIGH (fine) FREQUENCY control (100 kHz steps)
- NOTE: The receiver frequency should be set to the same frequency as the transmitter.

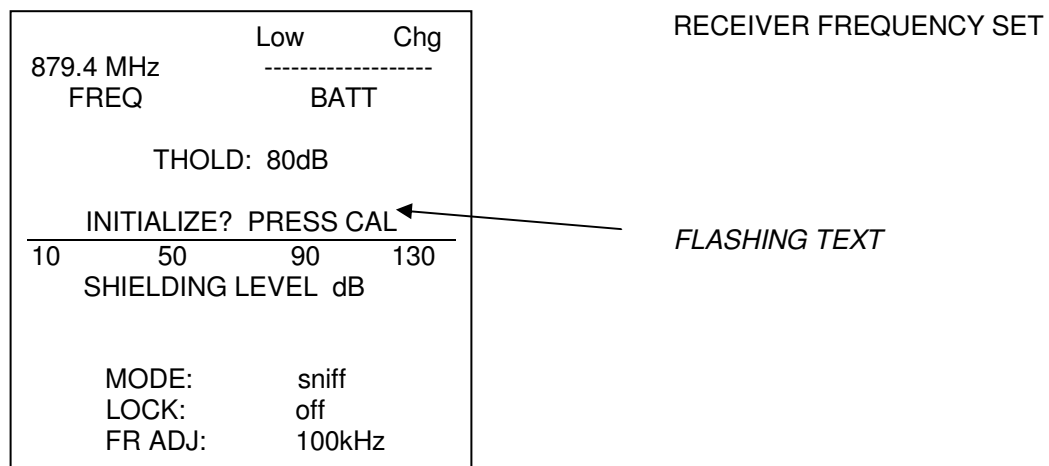

NOTE: The “INITIALIZE? PRESS CAL” warning will flash until a system level calibration is performed.

### 3.2.5 RCVR – Perform System Level Calibration

- ✓ Depress CAL switch. The “INITIALIZE? PRESS CAL” message is replaced by a shielding level bar graph. The SHIELDING LEVEL display should read nominally 60 dB.

NOTE: The 60 dB shielding level indication offsets the 60 dB output attenuation on the transmitter.

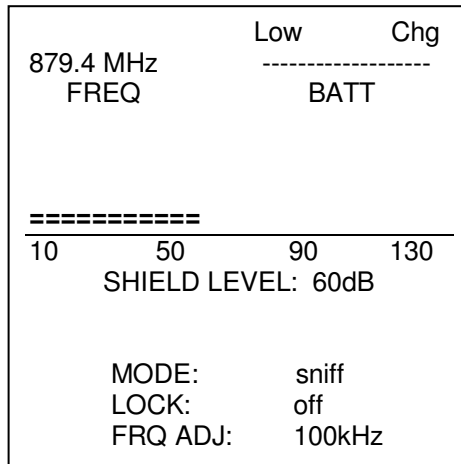

RECEIVER AFTER SYSTEM  
LEVEL CALIBRATION

### 3.2.6 TRANS – Set Atten to Operate Level

- ✓ Depress the ATTEN switch. The attenuator will advance from “60 dB” to the “0 dB” setting (0-dB attenuation).

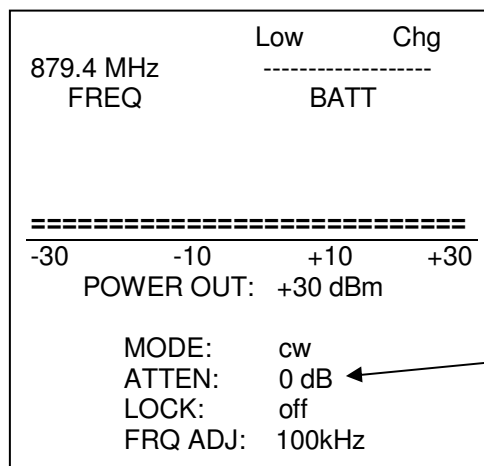

TRANSMITTER OPERATE  
LEVEL

OUTPUT ATTENUATION IS  
0dB

NOTE: The transmitter output power at the BNC is +30 dBm (1 watt) when the attenuator is set to 0 dB.

3.2.7 **RCVR – Verify Post-Calibration Level**

- ✓ The Operator should read a level less than 3 dB on the SHIELD LEVEL display.

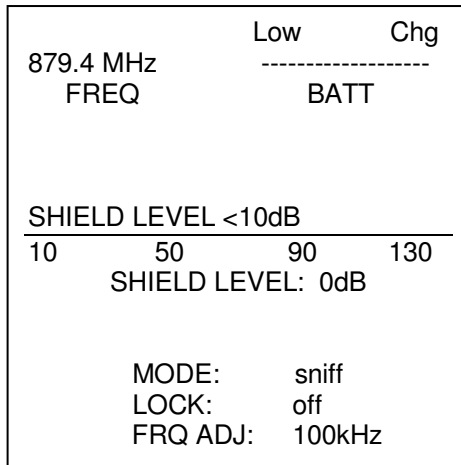

RECEIVER AFTER TRANSMITTER ATTENUATION REMOVED

3.2.8 **Shielded Room – Close Enclosure Door**

3.2.9 **RCVR – Read Shielding Level**

- ✓ The Operator reads SHIELD LEVEL display.

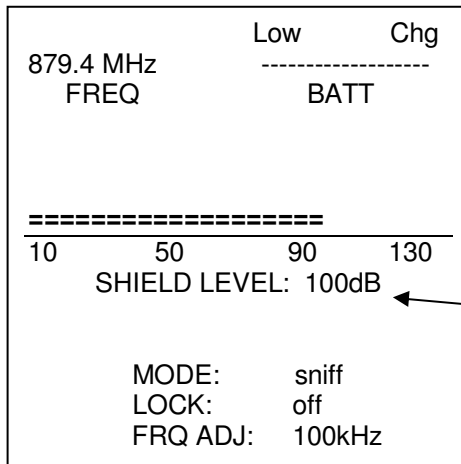

RECEIVER DISPLAYING SHIELD LEVEL

SHIELDING LEVEL OF ENCLOSURE

### 3.2.10 RCVR – Audio Threshold/Tone Usage

- ✓ Depress the ← → THRESHOLD switches until the desired threshold is set. Plug a Set of 32 ohm (Walkman-type) headphones in the jack on the top face of the unit.
- ✓ If the shielding level > threshold, no tone sounds.
- ✓ If the shielding level < threshold, a variable tone is emitted. Low frequency tones correspond to low (poor) shielding levels, while high frequency tones signify high (better) shielding levels.
- ✓ Depress the lock switch to toggle the control lock function. With the control lock enabled, the operator is protected against accidental control inputs invalidating a test.

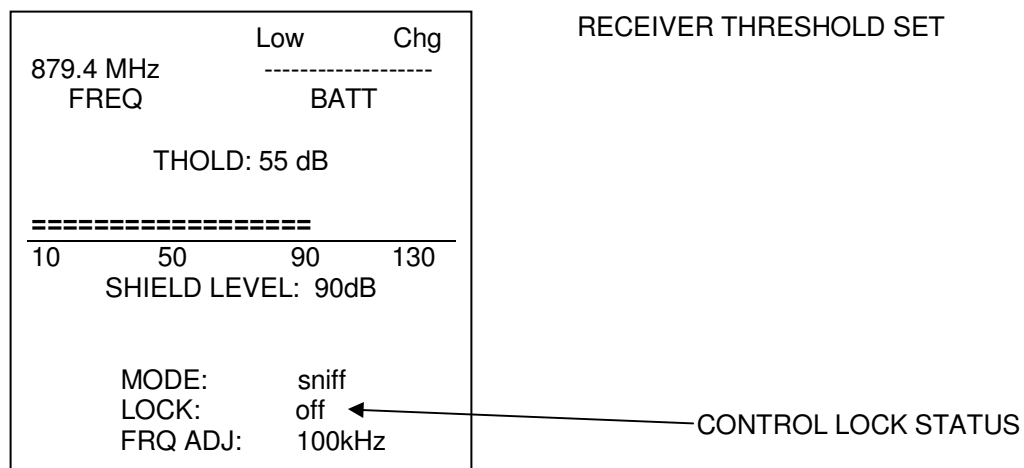

The PAMS Systems is now ready to test the shielding integrity of the enclosure.

### 3.3.0 “MONITOR (TS-31) MODE” OPERATIONAL SEQUENCE

- ✓ Verify that the monitor antennas are installed and connected to the switch assembly inputs ANT1 – ANT12. Note: The antennas are pre-installed on site and not included in the PAMS.

### 3.3.1 TRANS - Setup and Power-On

- ✓ Open enclosure door. Place transmitter inside enclosure.
- ✓ Rotate POWER switch to ON position.
- ✓ Verify that ATTEN is set to “60 dB.” Connect calibration cable END A to the Transmitter BNC output.
- ✓ Connect calibration cable (supplied with PAMS) END B to any of the 1x12 switch matrix inputs (labeled ANT1 – ANT12).
- ✓ Set the switch matrix select knob to couple calibration cable END B to the receiver.

**NOTE: It is very important that the Output Power is set to -30dBm. Power levels above +20dBm can cause permanent damage to the Receiver.**

### 3.3.2 TRANS – Frequency Set

- ✓ Adjust rotary LOW/HIGH (coarse) FREQ control (1 MHz steps)
- ✓ Depress F. DIGIT switch, FRQ ADJ toggles to “100 kHz”.
- ✓ Set rotary LOW/HIGH (fine) FREQ control (100 kHz steps)

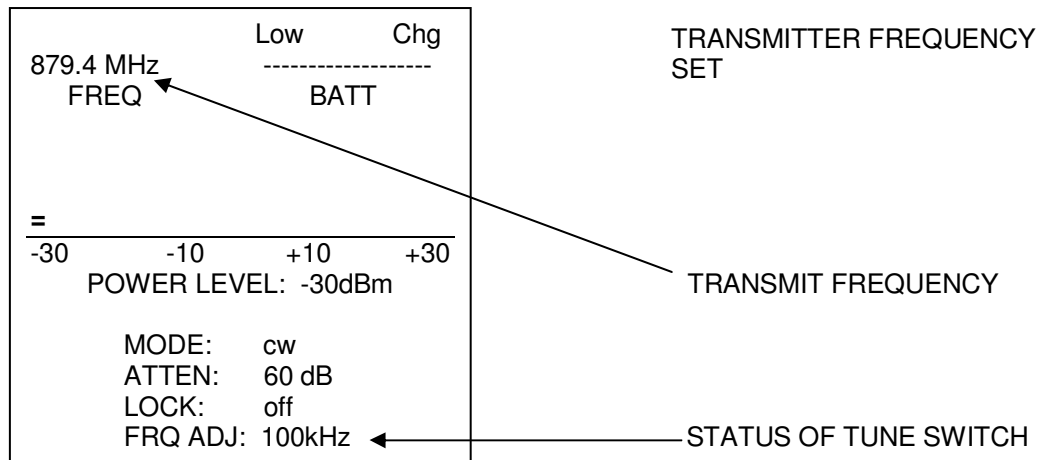

### 3.3.3 RCVR – Calibration Setup

- ✓ Connect the 1x12 switch matrix output (labeled “TO RCVR”) to the receiver BNC input.
- ✓ Power-On / Rotate POWER switch to the ON position.
- ✓ Depress the mode button until the LCD mode line reads monitor.

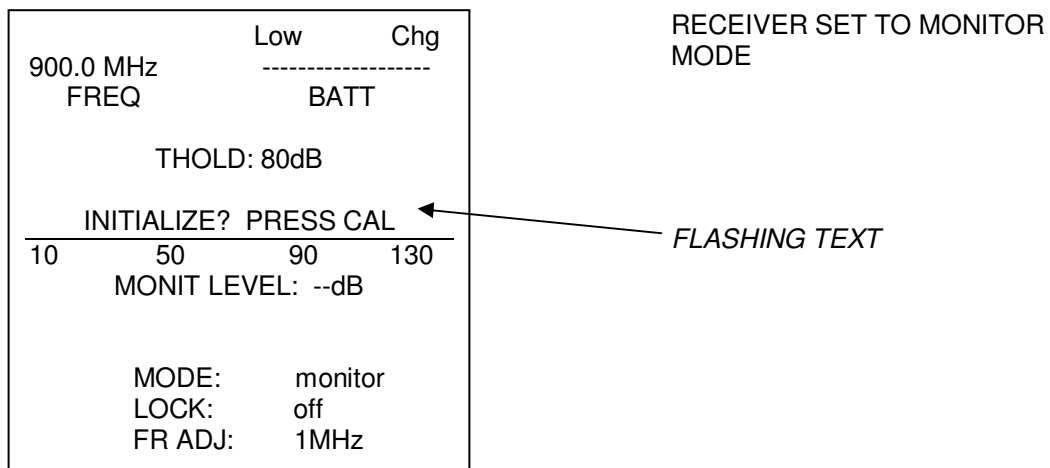

### 3.3.4 RCVR – Set Receiver Freq = Xmit Freq

- ✓ Adjust rotary LOW/HIGH (coarse) FREQUENCY control (1 MHz steps)
- ✓ Depress F. DIGIT switch, the FR ADJ status toggles to “100kHz”.
- ✓ Adjust rotary LOW/HIGH (fine) FREQUENCY control (100 kHz steps)

NOTE: The receiver frequency should be set to the same frequency as the transmitter.

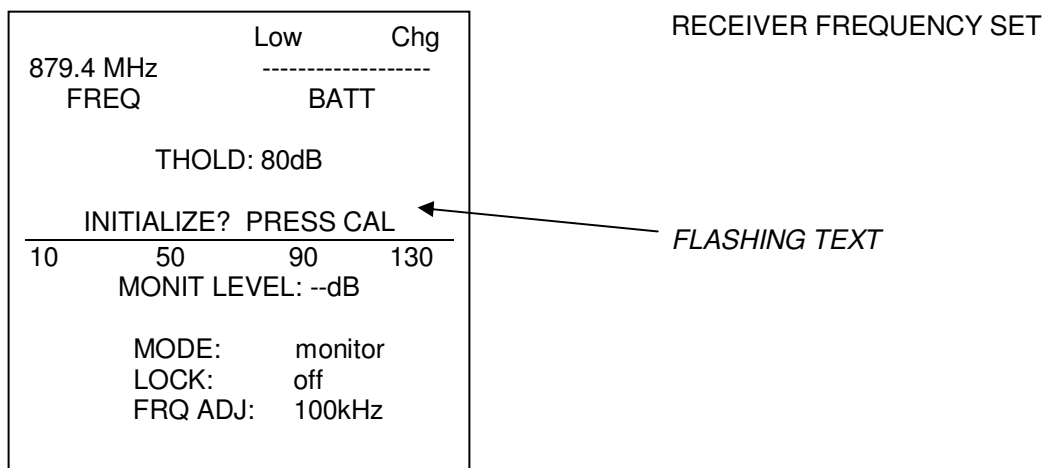

NOTE: The “INITIALIZE? PRESS CAL” warning will flash until a system level calibration is performed.

### 3.3.5 RCVR – Perform Calibration

- ✓ Depress CAL switch. The “INITIALIZE? PRESS CAL” message is replaced by a monitor-level bar graph, which indicates that the reference level is 0 dB. The MONIT LEVEL numeric display also reads 0 dB.

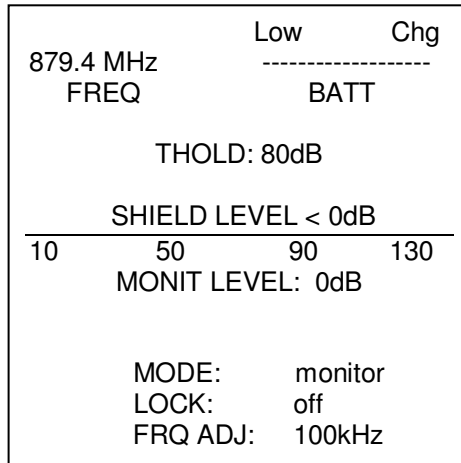

RECEIVER AFTER MONITOR CALIBRATION

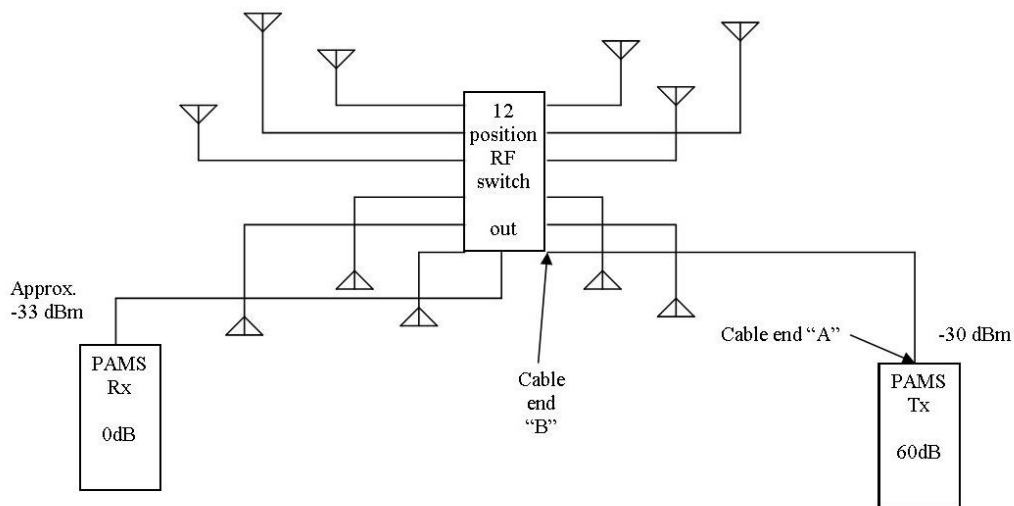

### 3.3.6 TRANS – Attach Antenna, Set Atten to Operate Level

- ✓ Remove calibration cable END A from the transmitter BNC output connector.
- ✓ Attach an omni-directional antenna to the transmitter BNC output jack.
- ✓ Depress the ATTEN switch. The attenuator mode will advance from 60 dB to the 0 dB setting (0 dB attenuation).

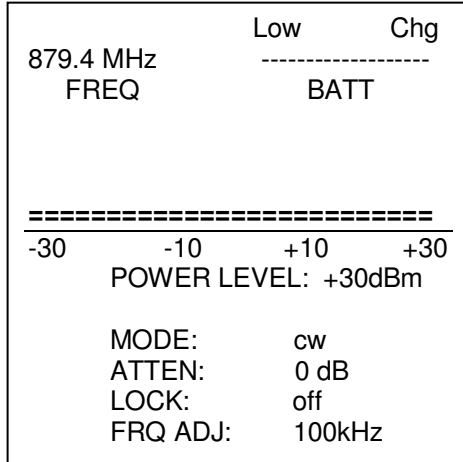

TRANSMITTER OPERATE  
LEVEL

3.3.7 SHIELDED ROOM - Close Door

3.3.8 RCVR – Operation Setup, Monitor Ant 1-12

- ✓ Remove calibration cable END B from the 1 x 12 switch matrix.
- ✓ Re-attach the monitor antennas, via 30-ft. cables, to each of the switch matrix inputs (ANT 1 – ANT 12).

3.3.9 RCVR – Monitor Measurement, Antennas 1-12

- ✓ Set the switch matrix to select “ANT 1.”
- ✓ Read and manually record the MONIT LEVEL (dB).
- ✓ Repeat the above sequence for antennas 2-12.

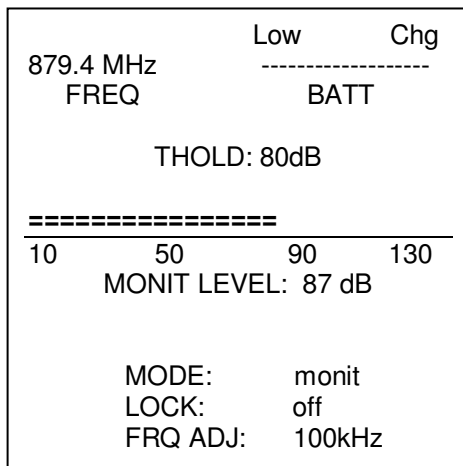

RECEIVER MONITOR LEVEL



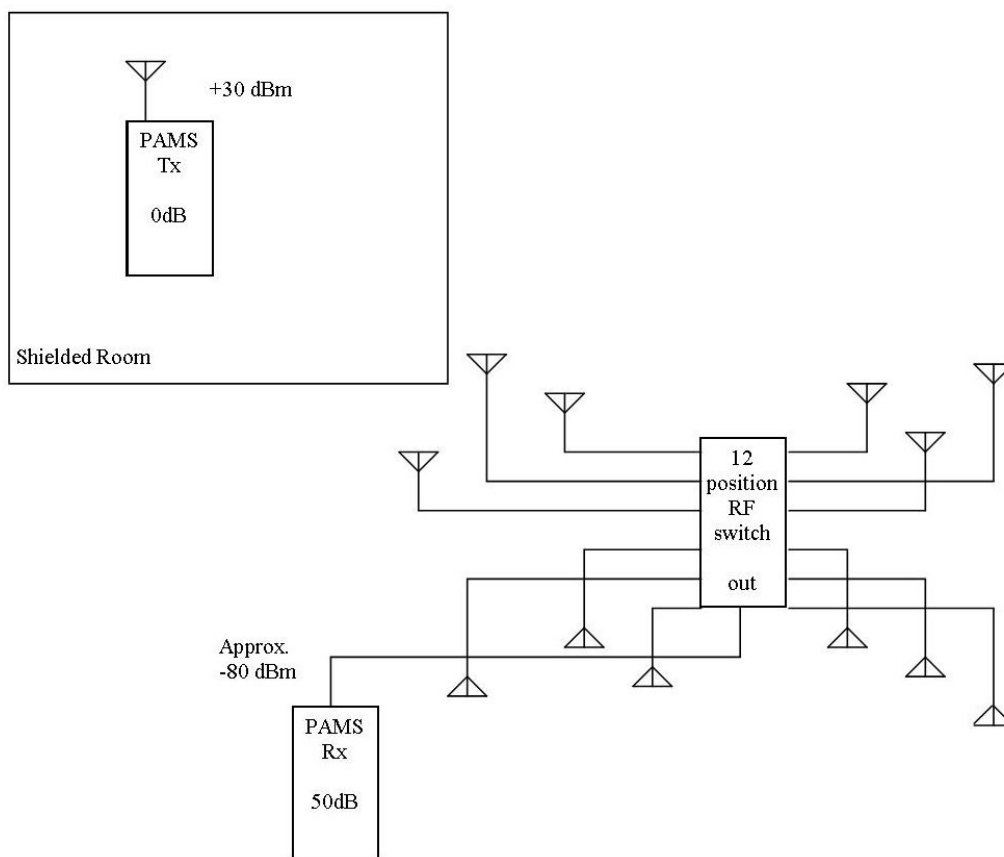

### 3.3.10 RCVR – Audio Threshold/Tone Usage

- ✓ Depress the ← → THRESHOLD switches until the desired threshold is set. Plug a set of 32 ohm (Walkman-type) headphones in the jack on the top face of the unit.
- ✓ If the monitor level > threshold, no tone sounds.
- ✓ If the monitor level < threshold, a variable tone is emitted. Low frequency tones correspond to low (poor) shielding levels, while high frequency tones signify high (better) shielding levels.

### 3.4.0 “BROADBAND MODE” SNIFFING OPERATIONAL SEQUENCE

#### 3.4.1 TRANS - Setup and Power-On

- ✓ Attach antenna of suitable frequency range to transmitter BNC output.
- ✓ Open enclosure door. Place unit inside enclosure.
- ✓ Rotate POWER switch to ON position to begin transmitting.
- ✓ Depress the MODE switch until the MODE status indicates the unit is in the “bb” mode.
- ✓ Depress the ATTEN switch. The ATTEN status reads “0 dB.”

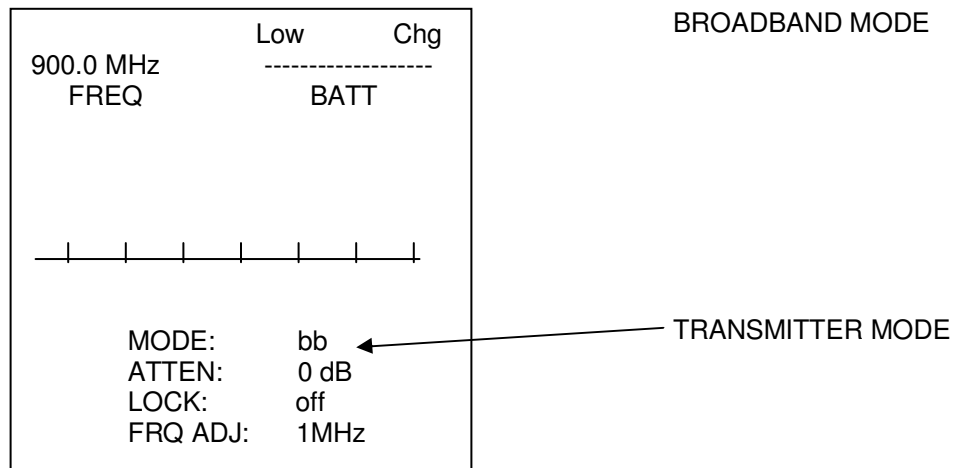

### 3.4.2 SPECTRUM ANALYZER – Sniffing Measurements

Operate the spectrum analyzer over a 750-1000 MHz band to search for leaking signals. Signals generated by the broadband mode are available over the band at 25 MHz intervals.

#### 4.0 Test and Inspection

##### 4.2.1 TRANS – Setup and Power-On

- ✓ Place the unit on a table 3-5 feet high
- ✓ Rotate POWER switch to ON position
- ✓ Allow 5 minutes for warm-up

##### 4.2.2 TRANS – Frequency Set to 904.2 MHz

- ✓ Adjust rotary LOW/HIGH (1 MHz steps) FREQ control
- ✓ Depress F. DIGIT switch, FR ADJ toggles to “fine”
- ✓ Adjust rotary LOW/HIGH (100 kHz steps) FREQ control

##### 4.2.3 RCVR – Setup and Power-On

- ✓ Place the RCVR on a table at a range of 10-20 feet from the Transmitter
- ✓ Power-on / rotate POWER switch to ON position

##### 4.2.4 RCVR – Set RCVR Freq equal to XMIT Freq

- ✓ Adjust rotary (coarse) FREQUENCY control (1 MHz steps)
- ✓ Depress switch, the FR ADJ status toggles to “fine”
- ✓ Adjust rotary LOW/HIGH (fine) FREQUENCY control (100 kHz steps)

##### 4.2.5 RCVR – Perform Cal

- ✓ Depress CAL switch. The “INITIALIZE? PRESS CAL” message is replaced by a shielding level bar graph. The SHIELD LEVEL display should read 60 dB.

##### 4.2.6 TRANS – Set Atten to Operate Level

- ✓ Depress the ATTEN switch. The attenuator will advance from “60 dB” to the “0 dB” setting (0-dB attenuation).

##### 4.2.7 RCVR – Read Post-Calibration Level

- ✓ The operator should read a 0 dB to 3 dB level on the SHIELD LEVEL display.

##### 4.2.8 TRANS – Set Atten to Operate Level

- ✓ In Power Adjust mode, turn FREQUENCY knob until the setting reads “30dB” (30 dB attenuation). Adjustment is made in 1dB steps.

##### 4.2.9 RCVR – Read Operating Level

- ✓ The operator should read a 30 dB +/- 5 dB on the SHIELD LEVEL display.

