

FDR-6603 Series

Dual Channel Optical Receiver User Manual

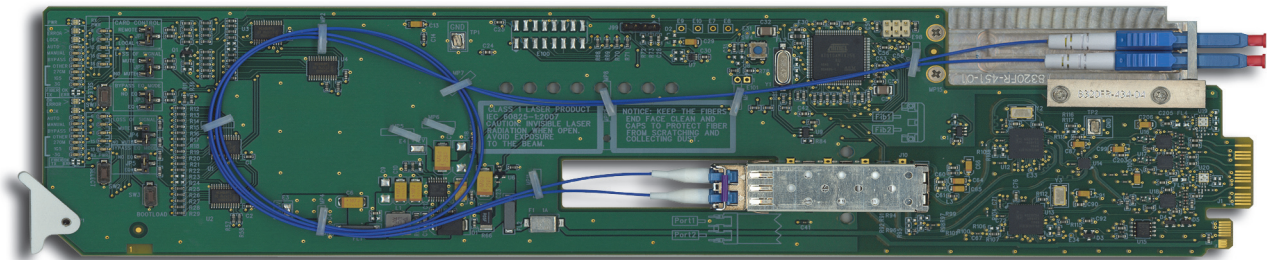

Thank you for choosing Ross

You've made a great choice. We expect you will be very happy with your purchase of Ross Technology.

Our mission is to:

1. Provide a Superior Customer Experience
 - offer the best product quality and support
2. Make Cool Practical Technology
 - develop great products that customers love

Ross has become well known for the Ross Video Code of Ethics. It guides our interactions and empowers our employees. I hope you enjoy reading it below.

If anything at all with your Ross experience does not live up to your expectations be sure to reach out to us at solutions@rossvideo.com.



David Ross
CEO, Ross Video
dross@rossvideo.com

Ross Video Code of Ethics

Any company is the sum total of the people that make things happen. At Ross, our employees are a special group. Our employees truly care about doing a great job and delivering a high quality customer experience every day. This code of ethics hangs on the wall of all Ross Video locations to guide our behavior:

1. We will always act in our customers' best interest.
2. We will do our best to understand our customers' requirements.
3. We will not ship crap.
4. We will be great to work with.
5. We will do something extra for our customers, as an apology, when something big goes wrong and it's our fault.
6. We will keep our promises.
7. We will treat the competition with respect.
8. We will cooperate with and help other friendly companies.
9. We will go above and beyond in times of crisis. *If there's no one to authorize the required action in times of company or customer crisis - do what you know in your heart is right. (You may rent helicopters if necessary.)*

FDR-6603 Series User Manual

- Ross Part Number: 6603DR-004-04
- Release Date: September 29, 2014.

Copyright

© 2014 Ross Video Limited. Ross®, openGear®, and any related marks are trademarks or registered trademarks of Ross Video Ltd. All other trademarks are the property of their respective companies. PATENTS ISSUED and PENDING. All rights reserved. No part of this publication may be reproduced, stored in a retrieval system, or transmitted in any form or by any means, mechanical, photocopying, recording or otherwise, without the prior written permission of Ross Video. While every precaution has been taken in the preparation of this document, Ross Video assumes no responsibility for errors or omissions. Neither is any liability assumed for damages resulting from the use of the information contained herein.

Patents

Patent numbers US 7,034,886; US 7,508,455; US 7,602,446; US 7,802,802 B2; US 7,834,886; US 7,914,332; US 8,307,284; US 8,407,374 B2; US 8,499,019 B2; US 8,519,949 B2; US 8,743,292 B2; GB 2,419,119 B; GB 2,447,380 B; and other patents pending.

Important Regulatory and Safety Notices to Service Personnel

Before using this product and any associated equipment, refer to the “**Important Safety Instructions**” listed below to avoid personnel injury and to prevent product damage.

Product may require specific equipment, and/or installation procedures to be carried out to satisfy certain regulatory compliance requirements. Notices have been included in this publication to call attention to these specific requirements.

Symbol Meanings



This symbol on the equipment refers you to important operating and maintenance (servicing) instructions within the Product Manual Documentation. Failure to heed this information may present a major risk of damage to persons or equipment.



Warning — *The symbol with the word “Warning” within the equipment manual indicates a potentially hazardous situation, which, if not avoided, could result in death or serious injury.*



Caution — *The symbol with the word “Caution” within the equipment manual indicates a potentially hazardous situation, which, if not avoided, may result in minor or moderate injury. It may also be used to alert against unsafe practices.*



Notice — *The symbol with the word “Notice” within the equipment manual indicates a potentially hazardous situation, which, if not avoided, may result in major or minor equipment damage or a situation which could place the equipment in a non-compliant operating state.*



ESD Susceptibility — *This symbol is used to alert the user that an electrical or electronic device or assembly is susceptible to damage from an ESD event.*

Important Safety Instructions



Caution — *This product is intended to be a component product of the DFR-8300 series frame. Refer to the DFR-8300 and OG3-FR Series Frame User Manual for important safety instructions regarding the proper installation and safe operation of the frame as well as its component products.*



Warning — *Certain parts of this equipment namely the power supply area still present a safety hazard, with the power switch in the OFF position. To avoid electrical shock, disconnect all A/C power cords from the chassis’ rear appliance connectors before servicing this area.*



Warning — *Service barriers within this product are intended to protect the operator and service personnel from hazardous voltages. For continued safety, replace all barriers after any servicing.*

This product contains safety critical parts, which if incorrectly replaced may present a risk of fire or electrical shock. Components contained with the product’s power supplies and power supply area, are not intended to be customer serviced and should be returned to the factory for repair. To reduce the risk of fire, replacements fuses must be the same time and rating. Only use attachments/accessories specified by the manufacturer.

EMC Notices

United States of America FCC Part 15

This equipment has been tested and found to comply with the limits for a class A Digital device, pursuant to part 15 of the FCC Rules. These limits are designed to provide reasonable protection against harmful interference when the equipment is operated in a commercial environment. This equipment generates, uses, and can radiate radio frequency energy and, if not installed and used in accordance with the instruction manual, may cause harmful interference to radio communications. Operation of this equipment in a residential area is likely to cause harmful interference in which case the user will be required to correct the interference at their own expense.



Notice — *Changes or modifications to this equipment not expressly approved by Ross Video Limited could void the user's authority to operate this equipment.*

CANADA

This Class “A” digital apparatus complies with Canadian ICES-003.

Cet appareil numérique de la classe “A” est conforme à la norme NMB-003 du Canada.

EUROPE

This equipment is in compliance with the essential requirements and other relevant provisions of CE Directive 93/68/EEC.

INTERNATIONAL

This equipment has been tested to **CISPR 22:1997** along with amendments **A1:2000** and **A2:2002**, and found to comply with the limits for a Class A Digital device.



Notice — *This is a Class A product. In domestic environments, this product may cause radio interference, in which case the user may have to take adequate measures.*

Maintenance/User Serviceable Parts

Routine maintenance to this openGear product is not required. This product contains no user serviceable parts. If the module does not appear to be working properly, please contact Technical Support using the numbers listed under the “Contact Us” section on the last page of this manual. All openGear products are covered by a generous 5-year warranty and will be repaired without charge for materials or labor within this period. See the “Warranty and Repair Policy” section in this manual for details.

Important Laser Safety Measures and Notices

Before using this product and any associated equipment, refer to the sections below so as to avoid personnel injury and to prevent product damage. For further safety information when using fiber products, consult the following publications:

- *IEC-60825- 2, Safety of Laser Products - Part 2: Safety of Optical Fiber Communication Systems (OFCS)* (for use outside of the U.S.A.)
- *ANSI Z136.2, Safe Use of Optical Fiber Communication Systems Utilizing Laser Diode and LED Sources* (for use in the U.S.A.)

Products may require specific equipment, and /or installation procedures be carried out to satisfy certain regulatory compliance requirements.



Caution — *Before operating or servicing this product, all personnel should be familiar with laser safety and fiber handling practices.*

Safety Measures for Operation

During normal operation of this product, heed the following safety measures:

- Do not stare at, or into, broken, or damaged, fibers.
- Do not stare at, or into, optical connectors.
- Only properly trained and authorized personnel shall be permitted to perform laser/fiber optic operations.
- Ensure that appropriate labels are displayed in plain view and in close proximity to the optical port on the protective housing/access panel of the terminal equipment.

Safety Measures for Maintenance and Servicing



Warning — *Do not use optical equipment, such as a microscope or an eye loupe, to stare at the energized fiber end. Doing so may damage your eyes.*

During maintenance and servicing of this product, only properly trained and authorized personnel shall be allowed to use optical test or diagnostic equipment.

Laser Information



*CLASS 1 LASER PRODUCT
IEC 60825-1:2007*

Caution — *INVISIBLE LASER RADIATION WHEN OPEN. AVOID EXPOSURE TO THE BEAM.*

Environmental Information

The equipment that you purchased required the extraction and use of natural resources for its production. It may contain hazardous substances that could impact health and the environment.

To avoid the potential release of those substances into the environment and to diminish the need for the extraction of natural resources, Ross Video encourages you to use the appropriate take-back systems. These systems will reuse or recycle most of the materials from your end-of-life equipment in an environmentally friendly and health conscious manner.

The crossed out wheelee bin symbol invites you to use these systems.



If you need more information on the collection, re-use, and recycling systems, please contact your local or regional waste administration.

You can also contact Ross Video for more information on the environmental performance of our products.

Company Address



Ross Video Limited

8 John Street
Iroquois, Ontario, K0E 1K0
Canada

Ross Video Incorporated

P.O. Box 880
Ogdensburg, New York
USA 13669-0880

General Business Office: (+1) 613 • 652 • 4886

Fax: (+1) 613 • 652 • 4425

Technical Support: (+1) 613 • 652 • 4886

After Hours Emergency: (+1) 613 • 349 • 0006

E-mail (Technical Support): techsupport@rossvideo.com

E-mail (General Information): solutions@rossvideo.com

Website: <http://www.rossvideo.com>

Contents

- Introduction 1**
 - Overview 1-2
 - Features..... 1-2
 - Functional Block Diagrams 1-3
 - User Interfaces 1-4
 - DashBoard Control System 1-4
 - Card-edge Controls..... 1-4
 - SNMP Monitoring and Control 1-4
 - Documentation Terms and Conventions..... 1-5

- Installation 2**
 - Before You Begin 2-2
 - Static Discharge..... 2-2
 - Unpacking..... 2-2
 - Working with Fiber Optic Connectors 2-2
 - Installing a FDR-6603 Series Card 2-3
 - Supported Rear Modules 2-3
 - Installing a Rear Module 2-3
 - Installing a Card 2-4
 - Cabling..... 2-6
 - Overview 2-6
 - Software Upgrades..... 2-7
 - To upgrade the software on a card 2-7

- User Controls 3**
 - Card Overview 3-2
 - Control and Monitoring Features..... 3-4
 - Status LEDs on the FDR-6603 Series 3-4

- DashBoard Menus 4**
 - Status Tabs 4-2
 - Signal Tab..... 4-2
 - Hardware Tab 4-3
 - Product Tab 4-3
 - Setup Menus 4-4
 - Alarms Menus..... 4-5

- Specifications 5**
 - FDR-6603 Technical Specifications 5-2
 - FDR-6603-H Technical Specifications..... 5-3

- Service Information 6**
 - Troubleshooting Checklist..... 6-2

Bootload Button.....	6-2
Warranty and Repair Policy.....	6-3

Introduction

In This Chapter

This chapter contains the following sections:

- Overview
- Functional Block Diagrams
- User Interfaces
- Documentation Terms and Conventions

A Word of Thanks

Congratulations on choosing an openGear FDR-6603 Series Dual Channel Optical Receiver. Your FDR-6603 series card is part of a full line of Digital Products within the openGear Terminal Equipment family of products, backed by Ross Video's experience in engineering and design expertise since 1974.

You will be pleased at how easily your new FDR-6603 series card fits into your overall working environment. Equally pleasing is the product quality, reliability and functionality. Thank you for joining the group of worldwide satisfied Ross Video customers!

Should you have a question pertaining to the installation or operation of your FDR-6603 series card, please contact us at the numbers listed on the back cover of this manual. Our technical support staff is always available for consultation, training, or service.

Overview

The FDR-6603 series provides the ability to transport digital video baseband signals over a fiber optic link, allowing for longer transport distances. SDI outputs are reclocked providing excellent jitter and return loss specifications. Both cards support serial digital data rates from 270Mbps up to 2.98Gbps (1080p). LED indicators at the front of the card identify the presence of incoming video and the identified signal data rates for each channel independently.

The FDR-6603 series is fully hot swappable with all active components on the front removable module. No active components are installed on the rear module. This design greatly reduces down time eliminating any need for users to access the back of the rack frame.

The FDR-6603 series is a fiber optic receiver to serial digital SDI converter capable of equalizing all common serial digital signals. Each channel of the FDR-6603 series equalizes the incoming SDI signal. Both channels provide three outputs each.

FDR-6603-H

The FDR-6603-H is a version of the FDR-6603 that includes high sensitivity receive SFPs for increased link budget. The FDR-6603-H is compatible with standard 1310nm transmitters, and the CWDM transmitters from 1270nm to 1610nm (attenuation may be required to reduce optical power below -9dBm).

Features

The following features are standard for the FDR-6603 series:

- Supports a wide variety of standards (SD, HD, and 3G SDI)
- Conforms to SMPTE 424M, SMPTE 292M, and SMPTE 259M
- Supports single-mode fiber
- Hot-swappable from front of frame with no external connect/reconnect required
- Provides two fiber optic inputs and six SDI outputs using a Full Rear Module (8320AR-044)
- Optical input range of 1210nm to 1610nm
- FDR-6603 offers an optical input sensitivity of -18dBm
- FDR-6603-H offers an optical input sensitivity of -28dBm
- LC/UPC optical connections
- Reclocking on all outputs at 270Mbps, 1.483Gbps, 1.485Gbps, 2.967Gbps, and 2.970Gbps
- Automatic detection of incoming data rate
- LED indicators for signal presence and data rate
- Reports status and configuration remotely via the DashBoard Control System
- Supports DataSafe
- Fits openGear frames
- High density with 20 cards per frame using Split Rear Modules (8320AR-045)
- Fully compliant with openGear specifications
- 5-year transferable warranty

Functional Block Diagrams

This section provides a functional block diagrams that outlines the signal flow of the FDR-6603 series.

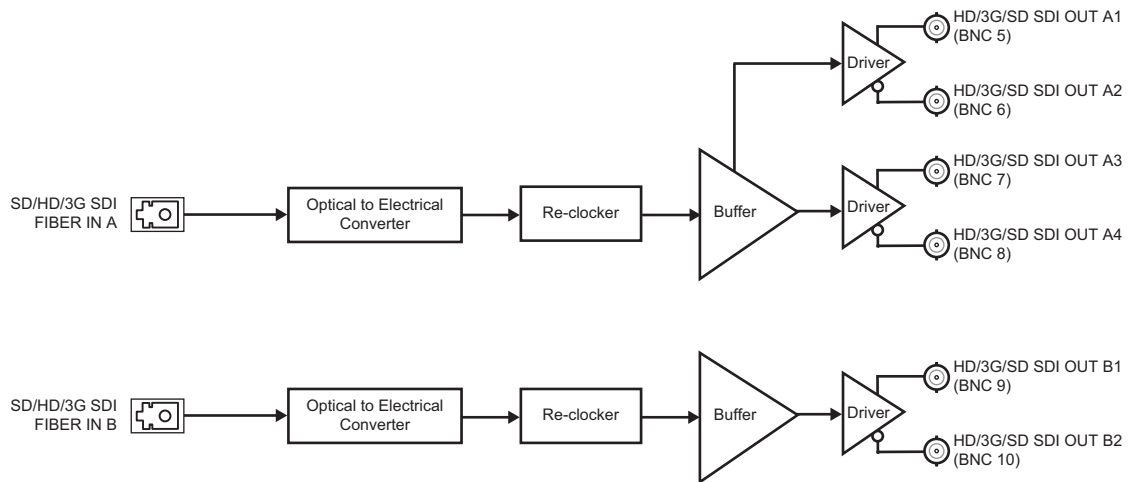

Figure 1.1 Simplified Block Diagram — 8320AR-044 Full Rear Module

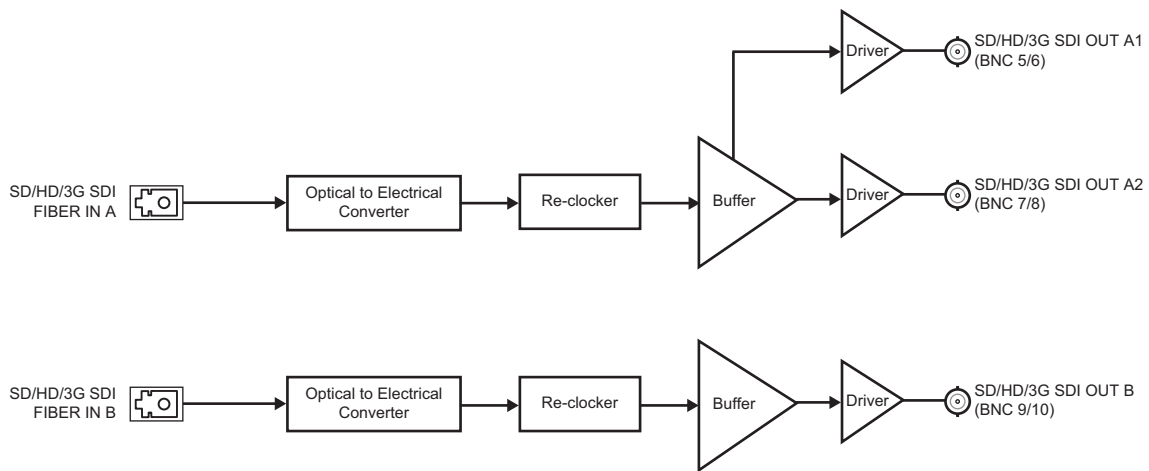

Figure 1.2 Simplified Block Diagram — 8320AR-045 Split Rear Module (Single Card only)

User Interfaces

The FDR-6603 series provides the following user interfaces.

DashBoard Control System

DashBoard enables you to monitor and control openGear frames and cards from a computer. DashBoard communicates with other cards in the openGear frame through the Network Controller Card.

For More Information on...

- using DashBoard, refer to the *DashBoard User Manual*.
- configuring the Network Controller Card, refer to the *MFC-8300 Series* or *MFC-OG3 Series User Manual*.
- the available menus in DashBoard for your FDR-6603 series card, refer to the section “**DashBoard Menus**” on page 4-1.

Card-edge Controls

The card-edge of the FDR-6603 series provides LEDs for monitoring communication activity, input optical power level, and the status of the reclocker. Jumpers are available for setting the card behavior on loss of input, and specifying the reclocking rate of the card.

For More Information on...

- card-edge LEDs, refer to the section “**Control and Monitoring Features**” on page 3-4.
- using the jumpers, refer to the section “**Card Overview**” on page 3-2.

SNMP Monitoring and Control

The Network Controller card in the openGear frame provides optional support for remote monitoring of your frame and using Simple Network Management Protocol (SNMP), which is compatible with many third-party monitoring and control tools.

For More Information on...

- the SNMP controls on this card, refer to your the Management Information Base (MIB) files for your card.
- SNMP Monitoring and Control, refer to the *MFC-8300 Series* or *MFC-OG3 Series User Manual*.

Documentation Terms and Conventions

The following terms and conventions are used throughout this manual.

Terms

The following terms are used:

- “**Board**” and “**Card**” refer to openGear terminal devices within openGear frames, including all components and switches.
- “**DashBoard**” refers to the DashBoard Control System.
- “**DFR-8321 series frame**” refers to all versions of the DFR-8321 series frames and any available options unless otherwise noted.
- “**FDR-6603**” refers to the non-high sensitivity version of the card.
- “**FDR-6603-H**” refers to the high sensitivity version of the card.
- “**FDR-6603 series**” refers to the FDR-6603 and FDR-6603-H unless otherwise noted.
- “**OG3-FR series frame**” refers to all versions of the OG3-FR series frames and any available options unless otherwise noted.
- “**openGear frame**” refers to DFR-8321 series and OG3-FR series frames that house the FDR-6603 series card.
- “**Operator**” and “**User**” refer to the person who uses the FDR-6603 series card.
- “**System**” and “**Video system**” refer to the mix of interconnected production and terminal equipment in your environment.

Conventions

The following conventions are used:

- The “**Operating Tips**” and “**Note**” boxes are used throughout this manual to provide additional user information.

Installation

In This Chapter

This chapter provides instructions for installing the Rear Module(s) for the FDR-6603 series installing a card into the frame, cabling details, and updating the software.

The following topics are discussed:

- Before You Begin
- Installing a FDR-6603 Series Card
- Cabling
- Software Upgrades

Before You Begin

Before proceeding with the instructions in this chapter, ensure that your openGear frame is properly installed according to the instructions in its manual.

Static Discharge

Throughout this chapter, please heed the following cautionary note:



ESD Susceptibility — *Static discharge can cause serious damage to sensitive semiconductor devices. Avoid handling circuit boards in high static environments such as carpeted areas and when synthetic fiber clothing is worn. Always exercise proper grounding precautions when working on circuit boards and related equipment.*

Unpacking

Unpack each card you received from the shipping container and ensure that all items are included. If any items are missing or damaged, contact your sales representative or Ross Video directly.

Working with Fiber Optic Connectors

Keep the following in mind when working with fiber optic connectors:

- Every time you are required to insert a connector into a device or mating sleeve, you must clean the connector. All exposed surfaces of the ceramic ferrule must be clean. Follow your facility practices of cleaning fiber optic connectors.
- Connectors must always be inserted into a device or have a dust cap on. Refer to **Figure 2.1** for dust cap locations.
- A poor optical connection is often similar to a poor electrical connection. Try removing the connector, cleaning, and re-inserting the connector. A bad connection can result in experiencing instability of signal, high loss, or a noisy signal.

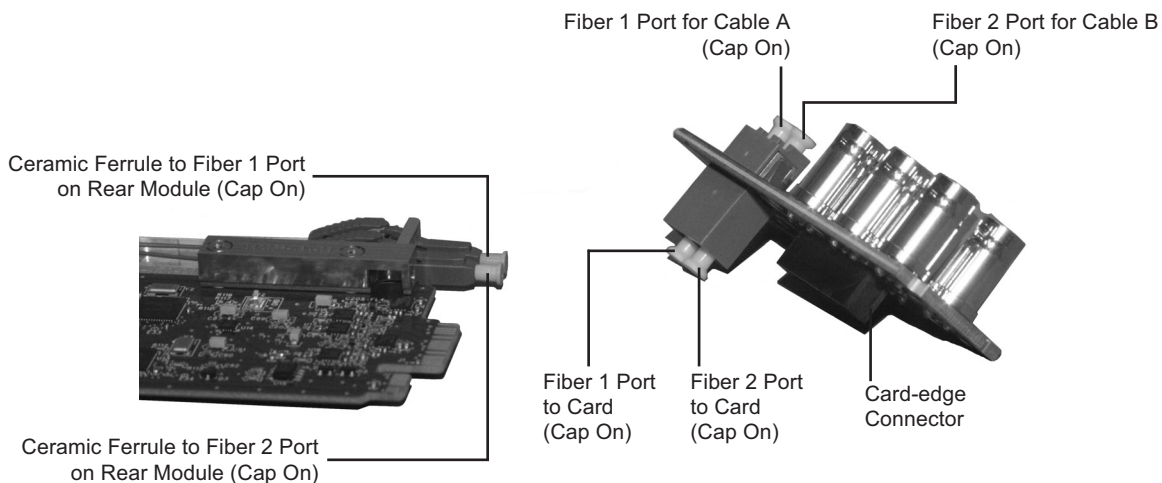

Figure 2.1 Card Connectors with Dust Caps Installed — 8320AR-044 Rear Module Shown

Installing a FDR-6603 Series Card

This section outlines how to install a Rear Module in an openGear frame. However, the specific Rear Module you need to install depends on your application.



Caution — Never attempt to look down the barrel of a connected fiber or device transmitting an optical signal. The transmitted light is not in the visible spectrum and may cause permanent eye damage. Turn off all laser sources before disconnecting devices.

Supported Rear Modules

The **8320AR-044** Full Rear Module or the **8320AR-045** Split Rear Module can be used. Note that the available cable designations differ between the type of module used. Refer to the section “Cabling” on page 2-6 for details.

Installing a Rear Module

If the Rear Module is installed, proceed to the section “Installing a Card” on page 2-4.



Caution — An optical power source of greater than -9dBm can damage the FDR-6603-H. Before installing the FDR-6603-H, verify that the actual optical power of your source is between -9dBm and -28dBm .

To install a rear module in your openGear frame

1. Locate the card frame slots on the rear of the frame.
2. Remove the Blank Plate from the slot you have chosen for the card installation.
3. Remove the dust caps from the Fiber ports on the Rear Module that faces the interior of the frame. Refer to **Figure 2.2** for dust cap locations.

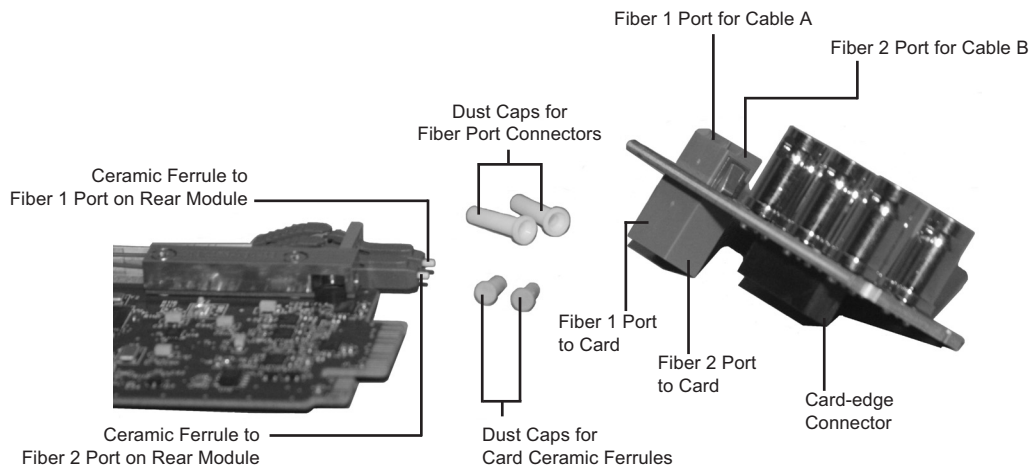

Figure 2.2 Card Connectors with Dust Caps Removed — 8320AR-044 Rear Module Shown

4. Install the bottom of the Rear Module in the **Module Seating Slot** at the base of the frame’s back plane.
5. Align the top hole of the Rear Module with the screw on the top-edge of the frame back plane.

6. Using a Phillips screwdriver and the supplied screw, fasten the Rear Module to the back plane of the frame. Do not over tighten.
7. Ensure proper frame cooling and ventilation by having all rear frame slots covered with Rear Modules or Blank Plates.

Installing a Card

Use the following procedure to install a card in an openGear frame:

1. Locate the Rear Module you installed in the procedure “**Installing a Rear Module**”.
2. Ensure that the Rear Module is one of the required models for the FDR-6603 series. You must use either a Full Rear Module (8320AR-044) or a Split Rear Module (8320AR-045).
3. Remove the dust caps from the **Fiber 1** and **Fiber 2** port connectors on the card end.
 - Refer to **Figure 2.3** for connector location.
 - Refer to the section “**Important Laser Safety Measures and Notices**” at the beginning of this manual for safety information when handling fiber optic components.

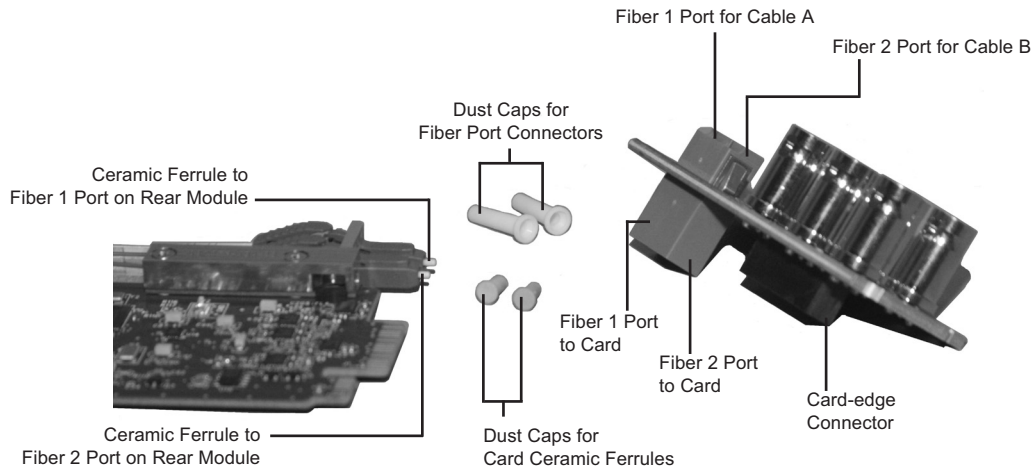

Figure 2.3 Card Connectors with Dust Caps Removed — 8320AR-044 Rear Module Shown

4. Ensure that the exposed surface of the ceramic ferrule of the connectors is clean. Refer to the section “**Working with Fiber Optic Connectors**” on page 2-2 for cleaning tips.
5. Hold the card by the edges and carefully align the card-edges with the slots in the frame.
6. Fully insert the card into the frame until the rear connection plus is properly seated in the Rear Module. You will feel a click when the card mates onto the rear module.
7. Verify whether your **Rear Module Label** is self-adhesive by checking the back of the label for a thin wax sheet. You must remove this wax sheet before affixing the label to the rear module.
8. Affix the supplied **Rear Module Label** to the BNC area of the Rear Module.
9. Remove the dust cap from the **Fiber 1** port (the topmost fiber optic port) on the Rear Module that faces the exterior of the frame. This is the port that you will insert your **Fiber A** optic cable into.
10. Remove the dust cap from the **Fiber 2** port (the bottom fiber optic port) on the Rear Module that faces the exterior of the frame. This is the port that you will insert your **Fiber B** optic cable into.

11. Ensure the ceramic ferrule of each connector is clean.
12. Cable your rear module as outlined in the section “**Cabling**” on page 2-6.

Cabling

This section provides information for connecting cables to the installed Rear Modules on the openGear frames. Connect the input and output cables according to the following sections.

The optical connector used to mate the card to the rear module is designed for blind mate optical connections. All fiber interfaces are single mode fibers.



Caution — Every time you are required to insert a connector into a device, or mating sleeve, you must clean the connector. All exposed surfaces of the ceramic ferrule must be clean. Follow your facility practices of cleaning fiber optic connectors.

Connectors must always be inserted into a device or have a dust cap on.

Overview

The FDR-6603 series is used with the following Rear Modules:

- **8320AR-044** Full Rear Module — Each rear module occupies two slots and accommodates one card. This rear module provides two optical inputs, and six SDI outputs. Refer to **Figure 2.4**.
- **8320AR-045** Split Rear Module — Each rear module occupies two slots and accommodates two cards. This rear module provides two optical inputs, and three SDI outputs per card. Refer to **Figure 2.5**.

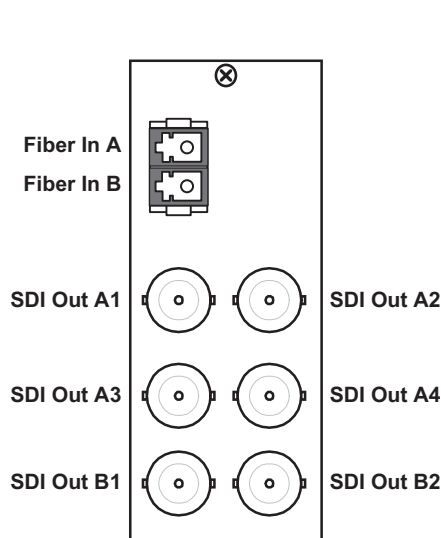

Figure 2.4 Cable Connections for the 8320AR-044 Rear Module

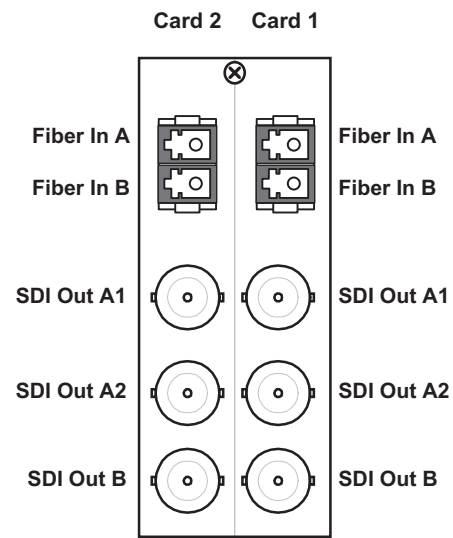

Figure 2.5 Cable Connections for the 8320AR-045 Rear Module



Caution — Do not exceed the maximum input power of -9dBm on the FDR-6603-H. Doing so will damage the card.

Software Upgrades

This section provides instructions for installing a license key and upgrading the software for your FDR-6603 series card using the DashBoard Control System.



Note — *This procedure assumes that you are running DashBoard version 3.0.0 or higher.*

To upgrade the software on a card

1. Contact Ross Technical Support for the latest software version file.
2. Display the **Device View** of the card by double-clicking its status indicator in the **Basic Tree View**.
3. From the **Device View**, click **Upload** to display the **Select file for upload** dialog.
4. Navigate to the *.bin upload file you wish to upload.
5. Click **Open**.
6. If you are upgrading a single card, click **Finish** to start the upgrade. Proceed to step 8.
7. If you are upgrading multiple cards:
 - Click **Next >** to display the **Select Destination** menu. This menu provides a list of the compatible cards based on the card selected in step 2.
 - Specify the card(s) to upload the file to by selecting the check box(es) for the cards you wish to upload the file to.
 - Verify that the card(s) you wish to upload the file to. The **Error/Warning** fields indicate any errors, such as incompatible software or card type mismatch.
 - Click **Finish**.
8. Monitor the upgrade.
 - The **Upload Status** dialog enables you to monitor the upgrade process.
 - The card reboots automatically once the file is uploaded. The card is temporarily taken offline.
 - The reboot process is complete once the status indicators for the **Card State** and **Connection** return to their previous status.



Operating Tip — *If you are running DashBoard version 2.3 or lower, you must click **Reboot** in the **Device** tab to complete the upgrade process.*

User Controls

In This Chapter

This chapter provides a general overview of the user controls available on the FDR-6603 series.

The following topics are discussed:

- Card Overview
- Control and Monitoring Features

Card Overview

This section provides a general overview of the card components. For information on the LEDs available on the card-edge, refer to the section “**Control and Monitoring Features**” on page 3-4.

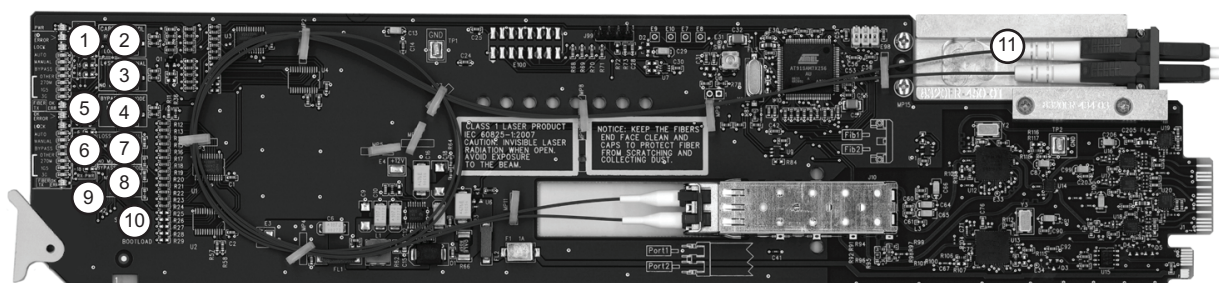

Figure 3.1 FDR-6603 — Components

1) Rx Power LEDs - Channel A	5) Select Switch - Channel A (SW1)	9) Select Switch - Channel B (SW2)
2) Card Control (JP1)	6) Rx Power LEDs - Channel B	10) Bootload Button (SW3)
3) Loss of Signal - Channel A (JP2)	7) Loss of Signal - Channel B (JP4)	11) Fiber Optic Connector
4) Bypass EQ Mode - Channel A (JP3)	8) Bypass EQ Mode - Channel B (JP5)	

1. Rx Power LEDs - Channel A

Five LEDs indicate the input optical power as detected by the optical module for Channel A. Refer to the section “**Rx Power LEDs**” on page 3-6 for details.

2. Card Control (JP1)

Use **JP1** to select whether the card is remotely configured (for example, via Dashboard or SNMP). Select one of the following options:

- **REMOTE** — This option enables the remote configuration. All parameters may be configured remotely. Data rate selection can also be configured locally using **SW1**, however, the jumper settings are ignored. Refer to the chapter “**Dashboard Menus**” on page 4-1 for information on the available Dashboard menus.
- **LOCAL** — This option disables the remote configuration. The card can only be configured using the card-edge controls. This option is useful to lock out remote configuration changes. This is the default setting.



Note — The card status and configuration can still be monitored remotely when **JP1** is set to **LOCAL**.

3. Loss of Signal - Channel A (JP2)

Use **JP2** to determine the card behavior on a loss of input on Channel A. Note that the **JP2** setting is only used when **JP1** is set to **LOCAL**. Select one of the following options:

- **MUTE** — This option mutes the card outputs when the input equalizer is unable to detect a valid input signal, or when the reclocker is unable to lock to the input.
- **NO MUTE** — This option does not mute the card outputs on loss of input or lock. This is the default setting.

4. Bypass EQ Mode - Channel A (JP3)

This jumper is not implemented.

5. Select Switch - Channel A (SW1)

Use **SW1** to set the reclocking rate of the card for Channel A. Pressing **SW1** cycles through the following options:

- **AUTO** — This option enables automatic rate detection on the card. It will automatically lock to input at any supported data rate (270Mbps, 1.5Gbps, or 3Gbps).
- **BYPASS** — This option enables the card to pass any data rate without reclocking. The output is set to the HD slew rate except when the input is a valid SD data rate (270Mbps).
- **270M** — This option configures the card to reclock at a rate of 270Mbps.
- **1.5G** — This configures the card to reclock at a rate of 1.5Gbps.
- **3G** — This configures the card to reclock at a rate of 3Gbps.

6. Rx Power LEDs - Channel B

These LEDs indicate the power consumption of the optical module for Channel B. Refer to the section “**Rx Power LEDs**” on page 3-6 for details.

7. Loss of Signal - Channel B (JP4)

Use **JP4** to determine the card behavior on a loss of input on Channel B. Same options as for Channel A.

8. Bypass EQ Mode - Channel B (JP5)

This jumper is not implemented.

9. Select Switch - Channel B (SW2)

Use **SW2** to set the reclocking rate of the card for Channel B. Same options as for Channel A.

10. Bootload Button (SW3)

SW3 is used for factory service in the unlikely event of a complete card failure. The Bootload process is further described in the section “**Bootload Button**” on page 6-2.

11. Fiber Optic Connector

The FDR-6603 series use a blind mate LC/UPC connector to interface with the Rear Modules (8320AR-044 and 8320AR-045). The rear module remains passive, while allowing for the FDR-6603 to be replaced without the need to remove any connected BNC or fiber optic cables. The blind mate connector is connected to the optical module via a single mode LC/UPC pigtail.

The fiber optic connector for the card includes a dust cap. The dust cap must stay on at all times when the card is not installed in a frame. Ensure to keep the fibers end face clean and use the caps to protect the fiber from scratches and collecting dust. Refer to the section “**Important Laser Safety Measures and Notices**” at the beginning of this manual for safety information.



Caution — *Do not exceed the maximum input power of -9dBm on the FDR-6603-H. Doing so will damage the card.*

Control and Monitoring Features

This section provides information on the LEDs for the FDR-6603 series. Refer to **Figure 3.2** for the location of the LEDs. For information on the Rx Power LEDs, refer to the section “**Rx Power LEDs**” on page 3-6.

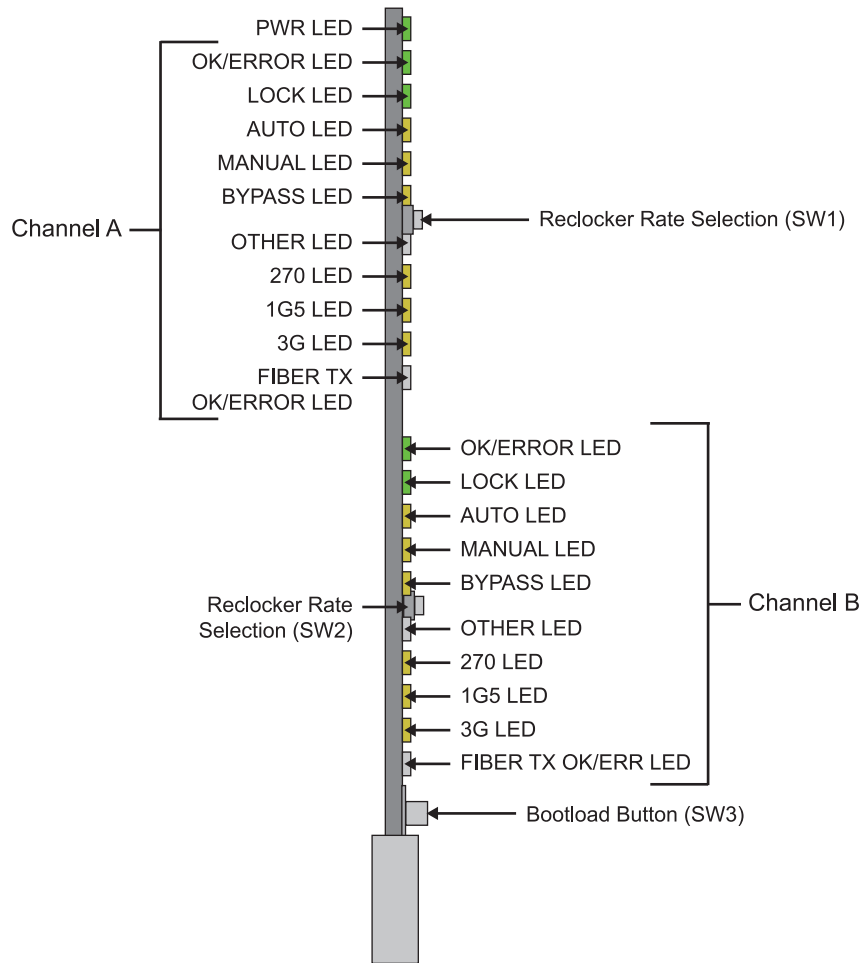

Figure 3.2 FDR-6603 Series Card-edge Controls

Status LEDs on the FDR-6603 Series

The front-edge of the card has LED indicators for alarms, and communication activity. Basic LED displays and descriptions are provided in **Table 3.1**.

Table 3.1 LEDs on the FDR-6603 Series

LED	Color	Display and Description
PWR	Green	When lit green, this LED indicates that the card is functioning normal and that no anomalies have been detected.
	Flashing Green	When flashing green, this LED indicates that the bootloader is currently running.
	Yellow	When lit yellow, this LED indicates that the CPU is booting.
	Red	When lit red, this LED indicates that the card is powering on or there is a fault condition.
	Off	When unlit, this LED indicates a lack of power to the card.

Table 3.1 LEDs on the FDR-6603 Series

LED	Color	Display and Description
OK/ERROR	Green	When lit, this LED indicates that a valid input signal is present.
	Red	When lit red, this LED indicates a valid input signal is not present.
LOCK	Green	When lit green, this LED indicates that the reclocker is locked to the input signal.
	Red	When lit red, this LED indicates that the reclocker is unable to lock to the input. This typically indicates that the input data rate is different from the configured reclocking rate, or that the input is an unsupported data rate.
	Off	When unlit, this LED indicates that the reclockers is set to Bypass.
AUTO	Yellow	When lit, this LED indicates that the reclocker is configured to lock to any supported input data rate, using an automatic rate detection scheme.
MANUAL	Yellow	When lit, this LED indicates that the reclocker is configured to a fixed data rate or to Bypass. When configured to a fixed data rate, automatic data rate detection is disabled.
BYPASS	Yellow	When lit, this LED indicates that the reclocker is manually configured to Bypass. The card output is not reclocked.
OTHER	Yellow	This LED is not implemented.
270	Yellow	When lit, this LED indicates that the reclocker is set to a fixed rate of 270Mbps (SD) or is configured in Auto mode and is locked to a 270Mbps SD signal.
1G5	Yellow	When lit, this LED indicates that the reclocker is set to a fixed rate of 1.5Gbps (HD), or is configured in Auto mode and is locked to a 1.5Gbps HD signal.
3G	Yellow	When lit, this LED indicates that the reclocker is set to a fixed rate of 3Gbps (HD), or is configured in Auto mode and is locked to a 3Gbps HD signal.
FIBER TX OK/ERROR	Green/Red	This LED is not implemented.

Rx Power LEDs

Table 3.2 provides information on the Rx Power LEDs located on the card. These LEDs indicate the input optical power as reported by the card optical module.

Table 3.2 Rx Power LEDs

Rx Power LEDs					Description
-6	-9	-12	-15	-18	
○	○	○	○	○	FDR-6603: The input optical power is greater than -6dBm FDR-6603-H: The input optical power is greater than -14dBm
	○	○	○	○	FDR-6603: The input optical power is between -6dBm and -9dBm FDR-6603-H: The input optical power is between -14dBm and -17dBm
		○	○	○	FDR-6603: The input optical power is between -9dBm and -12dBm FDR-6603-H: The input optical power is between -17dBm and -20dBm
			○	○	FDR-6603: The input optical power is between -12dBm and -15dBm FDR-6603-H: The input optical power is between -20dBm and -23dBm
				○	FDR-6603: The input optical power is between -15dBm and -18dBm FDR-6603-H: The input optical power is between -23dBm and -26dBm
					FDR-6603: The input optical power is less than -18dBm FDR-6603-H: The input optical power is less than -26dBm

○ = Illuminated LED

Reclocker Rate Selection LEDs

Table 3.3 provides information on the Reclocker Rate Selections (SW1 or SW2) and LED functions.

Table 3.3 Card Reclocker Rate Selection Button and LED Functions

Date Rate LED Displays						Description
AUTO	MANUAL	BYPASS	270M	1G5	3G	
○						Auto mode, card searching for valid rate
○			○			Auto mode, card detects and reclocks rate of 270Mbps
○				○		Auto mode, card detects and reclocks rate of 1.5Gbps
○					○	Auto mode, card detects and reclocks rate of 3Gbps
	○	○				Card is configured for Bypass mode
	○		○			Card is set to reclock 270Mbps
	○			○		Card is set to reclock 1.5Gbps
	○				○	Card is set to reclock 3Gbps

○ = Illuminated LED

DashBoard Menus

In This Chapter

This chapter summarizes the menus, items, and parameters available from DashBoard for the FDR-6603 series. Default parameters are noted with an asterisk (*).

The following topics are discussed:

- Status Tabs
- Setup Menus
- Alarms Menus

Status Tabs

This section summarizes the **Status** tabs displayed in DashBoard for the FDR-6603 series cards. The fields in the Status tabs vary in severity from green (valid), yellow (caution), to red (alarm). DashBoard reports the most severe alarm for a single field.

Signal Tab

Table 4.1 summarizes the read-only information displayed in the **Signal** tab.

Table 4.1 Signal Tab Items

Tab Title	Item	Parameters	Description
Signal - Channel #	Channel Status	OK	Indicates when the channel is functioning normally or if anomalies are detected on the specified channel
		No Input	
		Reclocker unlocked	
		SFP Hi Temp	
		SFP Lo Temp	
		SFP Hi Power	
		SFP Lo Power	
		SFP Tx Fault	
		SFP Not Detected	
	SDI Input	No Signal	Indicates when the SDI Input is present or if errors are detected on the specified channel
		Signal Present	
	SDI Output	Locked - #	Indicates the status of the SDI Output on the specified channel
		Undefined Rate	
		Bypass Reclocking	
		No Signal	
		No Signal (muted)	
		Unlocked	
	Optical Module Status	Unlocked (muted)	Indicates the status of the card Optical Module for the specified channel
		OK	
		No Signal	
		Temp High	
		Temp Low	
		Rx Power High	
		Tx Power High	
		Rx Power Low	
	Tx Power Low		

Table 4.1 Signal Tab Items

Tab Title	Item	Parameters	Description
Signal - Channel #	Optical Module Status	Tx Fault	Indicates the status of the card Optical Module for the specified channel
		Tx Disabled	
		Not Detected	
	Optical Rx Power (dBm) ^a	#	Indicates the optical power received by the Optical Module for the specified channel. This value is typically accurate ±3dBm for the FDR-6603, or ±4dBm for the FDR-6603-H.

- a. When operating at the upper or lower optical power limits, it is recommended to use an optical power meter to verify the received power.

Hardware Tab

Table 4.2 summarizes the read-only information displayed in the **Hardware** tab.

Table 4.2 Hardware Tab Items

Tab Title	Item	Parameters	Description
Hardware	HW Status	OK	Indicates the status of the hardware and whether a supported rear module is installed with the card
		Incomp I/O Module	
	Voltage (mV)	#	Supply Voltage
	Current (mA)	#	Current consumption of card
	Optical Module Temperature (C)	#	Internal temperature as reported by the SFP
	CPU Headroom	#	Processing power available
	RAM Available	##/##	On-board processing memory available
	Uptime (h)	#	Displays the number of hours since the last reboot of the card
Configuration Bank	#	Storage count	

Product Tab

Table 4.3 summarizes the read-only information displayed in the **Product** tab.

Table 4.3 Product Tab Items

Tab Title	Item	Parameters	Description
Product	Product	FDR-6603 or FDR-6603-H	
	Supplier	Ross Video Ltd.	
	Board Rev	##	
	Board S/N	#####	Indicates the card serial number
	Rear Module	#	Indicates the rear module installed
	Software Rev	##.##	Indicates the software version

Setup Tab

Table 4.4 summarizes the Setup options available in DashBoard.

Table 4.4 Setup Menu Items

Menu Title	Item	Parameters	Description
Setup - Channel #	Reclock Rate	Auto*	The card automatically detects the incoming data rate for the specified channel
		Bypass	The card does not reclock the input for the specified channel
		270 Mb/s	The reclocker is set to 270Mbps for the specified channel
		1.5 Gb/s	The reclocker is set to 1.5Gbps for the specified channel
		3 Gb/s	The reclocker is set to 3Gbps for the specified channel
	Mute on Loss of Input ^a	Selected	The output is muted on loss of input for the specified channel
		Cleared*	The output is not muted on loss of input for the specified channel
Setup	Edit Permission	Unlocked*	All configurable menu options are editable
		Locked	All configuration menu options, except this one, are locked and are read-only
		Local Only	JP1 is set to LOCAL and all configuration parameters, including this one, are locked and read-only
	Factory Defaults Reset	Reset	Resets all the settings

- a. It is recommended to disable this option to avoid false mutings of the input whenever the input reading is at a low power level.

Alarms Tab

Table 4.5 summarizes the **Alarms** options available in DashBoard.

Table 4.5 Alarms Menu Items

Menu Title	Item	Parameters	Description
Alarms - Optical Module Alarms	Alarm on Abnormal Power	Selected*	HW Status field reports when the power consumption of the SFP module is not in range (high/low)
		Cleared	Disables this alarm
	Alarm on Abnormal Temperature	Selected*	HW Status field reports when the temperature of the SFP module is not in range (high/low)
		Cleared	Disables this alarm
Alarms - Channel #	Alarm on Loss of Input	Selected*	Signal Status field reports a loss of input for the specified channel
		Cleared	Disables this alarm for the specified channel

Specifications

In This Chapter

This chapter includes the technical specifications for the FDR-6603 and FDR-6603-H. Note that specifications are subject to change without notice.

The following topics are discussed:

- FDR-6603 Technical Specifications
- FDR-6603-H Technical Specifications

FDR-6603 Technical Specifications

This section provides the technical specifications for the FDR-6603.

Table 5.1 FDR-6603 Technical Specifications

Category	Parameter	Specification
Optical Inputs	Number of Inputs	2
	SMPTE Standards Accommodated	SMPTE 259M, SMPTE 292M, SMPTE 424M
	Operating Wavelength Range	1260nm to 1620nm
	Input Power Operating Range (Color Bars)	<ul style="list-style-type: none"> -3dBm to -18dBm @ 2.97Gbps -3dBm to -19dBm @ 270Mbps and 1.5Gbps
	Input Power Operating Range (Pathological)	<ul style="list-style-type: none"> -3dBm to -17dBm @ 2.97Gbps -3dBm to -18dBm @ 270Mbps and 1.5Gbps
	Receiver Overload	At values above -3dBm
	Connector Type	Single Mode, LC/UPC, PIN
SDI Outputs	Number of Outputs	Full Rear Module (8320AR-044): 6 Split Rear Module (8320AR-045): 3
	SMPTE Standards Accommodated	SMPTE 259M, SMPTE 292M, SMPTE 424M
	Impedance	75ohm
	Return Loss	>15dB to 1.485GHz >10dB from 1.485GHz to 2.97GHz
	Signal Level	800mV ±10%
	DC Offset	0V ±50mV
	Rise and Fall Time (20-80%)	<ul style="list-style-type: none"> 700ps. Typical (270Mbps) 120ps. Typical (1.485Gbps, 2.97Gbps)
	Overshoot	<10%
	Connector Type	BNC
Environmental	Operating Range	0°C to 40°C
Power	Power Consumption	<5W

FDR-6603-H Technical Specifications

This section provides the technical specifications for the FDR-6603-H.



Caution — Do not exceed the maximum input power of -9dBm on the FDR-6603-H. Doing so will damage the card.

Table 5.2 FDR-6603-H Technical Specifications

Category	Parameter	Specification
Optical Inputs	Number of Inputs	2
	SMPTE Standards Accommodated	SMPTE 259M, SMPTE 292M, SMPTE 424M
	Operating Wavelength Range	1260nm to 1620nm
	Input Power Operating Range (Color Bars)	<ul style="list-style-type: none"> -9dBm to -28dBm @ 2.97Gbps -9dBm to -28dBm @ 270Mbps and 1.5Gbps
	Input Power Operating Range (Pathological)	<ul style="list-style-type: none"> -9dBm to -28dBm @ 2.97Gbps -9dBm to -28dBm @ 270Mbps and 1.5Gbps
	Receiver Overload	At values above -9dBm
	Maximum Input Power	-9dBm
	Connector Type	Single Mode, LC/UPC, APD
SDI Outputs	Number of Outputs	Full Rear Module (8320AR-044): 6 Split Rear Module (8320AR-045): 3
	SMPTE Standards Accommodated	SMPTE 259M, SMPTE 292M, SMPTE 424M
	Impedance	75ohm
	Return Loss	>15dB to 1.485GHz >10dB from 1.485GHz to 2.97GHz
	Signal Level	800mV ±10%
	DC Offset	0V ±50mV
	Rise and Fall Time (20-80%)	700ps. Typical (270Mbps) 120ps. Typical (1.485Gbps, 2.97Gbps)
	Overshoot	<10%
	Connector Type	BNC
Environmental	Operating Range	0°C to 40°C
Power	Power Consumption	<5W

Service Information

In This Chapter

This chapter contains the following sections:

- Troubleshooting Checklist
- Warranty and Repair Policy

Troubleshooting Checklist

Routine maintenance to this openGear product is not required. In the event of problems with your FDR-6603 series card, the following basic troubleshooting checklist may help identify the source of the problem. If the frame still does not appear to be working properly after checking all possible causes, please contact your openGear products distributor, or the Technical Support department at the numbers listed under the “**Contact Us**” section.



Caution — *Every time you are required to insert a connector into a device, or mating sleeve, you must clean the connector. All exposed surfaces of the ceramic ferrule must be clean. Follow your facility practices of cleaning fiber optic connectors.*

Connectors must always be inserted into a device or have a dust cap on.

1. **Visual Review** — Performing a quick visual check may reveal many problems, such as connectors not properly seated or loose cables. Check the card, the frame, and any associated peripheral equipment for signs of trouble.
2. **Power Check** — Check the power indicator LED on the distribution frame front panel for the presence of power. If the power LED is not illuminated, verify that the power cable is connected to a power source and that power is available at the power main. Confirm that the power supplies are fully seated in their slots. If the power LED is still not illuminated, replace the power supply with one that is verified to work.
3. **Input Signal Status** — Verify that source equipment is operating correctly and that a valid signal is being supplied.
4. **Output Signal Path** — Verify that destination equipment is operating correctly and receiving a valid signal.
5. **Unit Exchange** — Exchanging a suspect unit with a unit that is known to be working correctly is an efficient method for localizing problems to individual units.

Bootload Button

In the unlikely event of a complete card failure, you may be instructed by a Ross Technical Support specialist to perform a complete software reload on the card.

To reload the software on a card

1. Eject the card from the frame.
2. Press and hold the **Bootload** button, while re-inserting the card into the frame.
3. Release the button.
 - The **PWR** LED flashes green while the card is waiting for a new software load.
 - If a new software load is not sent to the card within 60 seconds, the card will attempt to restart with its last operational software load.
 - Software loads can be uploaded to the card via the ethernet connection on the rear of the frame.

Warranty and Repair Policy

The FDR-6603 series card is warranted to be free of any defect with respect to performance, quality, reliability, and workmanship for a period of FIVE (5) years from the date of shipment from our factory. In the event that your FDR-6603 series card proves to be defective in any way during this warranty period, Ross Video Limited reserves the right to repair or replace this piece of equipment with a unit of equal or superior performance characteristics.

Should you find that the FDR-6603 series card has failed after your warranty period has expired, we will repair your defective product should suitable replacement components be available. You, the owner, will bear any labor and/or part costs incurred in the repair or refurbishment of said equipment beyond the FIVE (5) year warranty period.

In no event shall Ross Video Limited be liable for direct, indirect, special, incidental, or consequential damages (including loss of profits) incurred by the use of this product. Implied warranties are expressly limited to the duration of this warranty.

This FDR-6603 Series User Manual provides all pertinent information for the safe installation and operation of your openGear Product. Ross Video policy dictates that all repairs to the FDR-6603 are to be conducted only by an authorized Ross Video Limited factory representative. Therefore, any unauthorized attempt to repair this product, by anyone other than an authorized Ross Video Limited factory representative, will automatically void the warranty. Please contact Ross Video Technical Support for more information.

In Case of Problems

Should any problem arise with your FDR-6603 series card, please contact the Ross Video Technical Support Department. (Contact information is supplied at the end of this publication.)

A Return Material Authorization number (RMA) will be issued to you, as well as specific shipping instructions, should you wish our factory to repair your FDR-6603 series card. If required, a temporary replacement frame will be made available at a nominal charge. Any shipping costs incurred will be the responsibility of you, the customer. All products shipped to you from Ross Video Limited will be shipped collect.

The Ross Video Technical Support Department will continue to provide advice on any product manufactured by Ross Video Limited, beyond the warranty period without charge, for the life of the equipment.

Contact Us

Contact our friendly and professional support representatives for the following:

- Name and address of your local dealer
- Product information and pricing
- Technical support
- Upcoming trade show information

Technical Support

Telephone: +1 613 • 652 • 4886
After Hours Emergency: +1 613 • 349 • 0006
Email: techsupport@rossvideo.com

General Information

Telephone: +1 613 • 652 • 4886
Fax: +1 613 • 652 • 4425
Email: solutions@rossvideo.com
Website: <http://www.rossvideo.com>

Visit Us

Visit our website for:

- Company information and news
- Related products and full product lines
- Online catalog
- Testimonials