

# TPS3 12 & TPS3 15

Surge Protective Device



User Manual - USA

**SIEMENS**



# **WARNING - Hazardous Voltage & Shock Hazard**

Failure to Follow These Instructions Could Result in Death or Serious Injury

- Only qualified licensed electricians should install or service SPDs
- Hazardous voltages exist within SPDs
- SPDs should never be installed or serviced when energized
- Use appropriate safety precautions including Personal Protection Equipment
- Failure to follow these instructions can result in death, serious injury, and/or equipment damage.
- This manual shall be read in entirety prior to installing

## **Bonding and Grounding Hazard**

Verify that the neutral conductor in the service entrance equipment is bonded to ground in accordance with the National Electrical Code (NEC®) and all applicable codes.

Verify that the neutral terminal (XO) on the secondary side of distribution transformers are grounded to the system ground in accordance with the NEC® and all applicable codes.

During installation into an electrical system the SPD must not be energized until the electrical system is completely installed, inspected and tested. All conductors must be connected and functional including the neutral (if required). The voltage rating of the SPD and system must be verified before energizing the SPD.

Failure to follow these guidelines can lead to abnormally high voltages at the SPD. This may cause the SPD to fail. The warranty is voided if the SPD is incorrectly installed and/or if the neutral conductor in the service entrance equipment or downstream of separately derived systems is not bonded to ground in accordance with the NEC®.

## **Do Not Hi-Pot Test SPDs**

Any factory or on-site testing of power distribution equipment that exceeds normal operating voltage such as high-potential insulation testing, or any other tests where the suppression components will be subjected to higher voltage than their rated Maximum Continuous Operating Voltage (MCOV) must be conducted with the SPD disconnected from the power source. For 4-wire systems, the neutral connection at the SPD must also be disconnected prior to performing high-potential testing and then reconnected after test completion.

Failure to disconnect SPD and associated components during elevated voltage testing will damage the SPD and will void the warranty.

# Table of Contents

<b>FAILURE TO FOLLOW THESE INSTRUCTIONS COULD RESULT IN DEATH OR SERIOUS INJURY .....</b>	<b>2</b>
Do Not Hi-Pot Test SPDs .....	2
<b>INTRODUCTION.....</b>	<b>1</b>
Warning and Safety Information .....	1
Qualified Person.....	1
Danger.....	1
Warning .....	1
Caution.....	1
Do Not Hi-Pot Test SPDs .....	1
Limited Warranty.....	1
Unpacking and Preliminary Inspection .....	1
Storage .....	1
<b>GENERAL INFORMATION .....</b>	<b>2</b>
Product Family Outline .....	2
Type 1 SPD .....	2
Internal Protection.....	2
Service Guidelines.....	2
Simplified Explanation of Operation.....	2
Industry Standards Changes - 2009 .....	2
Parallel Connection .....	4
Precautionary Statement Regarding SPDs on Ungrounded Systems.....	4
Cascade Surge Protection .....	4
Unpacking & Preliminary Inspection.....	4
<b>PRE-INSTALLATION AND PLANNING .....</b>	<b>4</b>
Operating Environment.....	4
Line Side versus Load Side Installation .....	4
Audible Noise .....	4
Mounting, Dimensions, and Weight.....	4
Service Clearance.....	5
Lead Lengths & Maximizing SPD Performance.....	5
Shortest Leads Possible.....	5
Voltage Rating.....	5
Circuit Breaker and Disconnect Switch .....	5
Terminals .....	6
Wire Size and Installation Torque .....	6
System Grounding.....	6
NEMA 3R Drain Holes for Standard Steel Enclosure.....	6
Optional Flush Mount Installation Considerations .....	7
Retro-fit to an Existing Panel with No Available Breaker Positions.....	7
Disconnect Switch (Opt. on TPS3 12, Std. on TPS3 15) .....	7
UL 1283 required language concerning the installation of EMI Filters .....	7
<b>TPS3 12 AND TPS3 15 INSTALLATION INSTRUCTIONS .....</b>	<b>8</b>
<b>OPERATION .....</b>	<b>10</b>
Surge Counter Reset: (if equipped) Resets optional surge counter to zero (0) .....	10
Diagnostic Display Panel.....	10
Surge Counter Option.....	10
Dry Contact Option .....	11
Remote Monitor Accessory .....	11
<b>MAINTENANCE .....</b>	<b>11</b>
Troubleshooting & Service .....	11
Module Replacement & Service .....	11
Display Replacement .....	12
TPS3 15 Series with two modules .....	12
Technical Support.....	12
<b>Figures</b>	
Figure 1: SPD Types .....	2
Figure 2: Typical Parallel Connected SPD on Electrical Panel.....	4
Figure 3: NEMA 3R Drain Holes .....	6
Figure 7: Rotating Module .....	6
Figure 6: Flush Mount Installation.....	7
Figure 3: Panel Installation .....	8
Figure 4: Electrical Drawings.....	9
Figure 5: Mechanical Drawings .....	9
Figure 8: Horizontal Display .....	10
Figure 9: Vertical Display .....	10
Figure 10: Dry Contact Connection Configuration .....	11
<b>Tables</b>	
Table 1: Model Number Decoder.....	3
Table 2: Weight & Dimensions.....	5

## Introduction

Thank you for choosing Siemens TPS3 Surge Protective Device (SPD). This is a high quality, high energy surge suppressor designed to protect sensitive equipment from damaging transient overvoltages.

Proper installation is important to maximize performance. Please follow the steps outlined herein.

This entire User Manual should be read prior to beginning installation. These instructions are not intended to replace national or local codes. Follow all applicable electrical codes to ensure compliance. Installation of this SPD should only be performed by qualified electrical personnel.

All Siemens SPDs are extensively tested in accordance with industry standards such as ANSI/IEEE C62.41.1, C62.41.2, C62.45, C62.62, C62.72, UL 1449, UL 1283, IEC 61643, etc.

### Warning and Safety Information

This equipment contains hazardous voltages. Death, serious injury, or property damage can result if safety instructions are not followed. Only qualified personnel should work on or around this equipment after becoming thoroughly familiar with all warnings, safety notices, and maintenance procedures contained herein.

The successful and safe operation of this equipment is dependent upon proper handling, installation, operation, and maintenance.

### Qualified Person

For the purposes of this manual and product labels, a QUALIFIED PERSON is one who is familiar with the installation, construction, and operation of this equipment, and the hazards involved. In addition, he or she has the following qualifications:

- (a) Is trained and authorized to energize, de-energize, clear, ground and tag circuits and equipment in accordance with established safety practices.
- (b) Is trained in the proper care and use of personal protective equipment (PPE) such as rubber gloves, hard hat, safety glasses or face shields, flash clothing, etc. in accordance with established safety practices.
- (c) Is trained in rendering first aid.

### Danger

For the purposes of this manual and product labels, DANGER indicates an imminently hazardous situation, which, if not avoided, will result in death or serious injury.

### Warning

For the purposes of this manual and product labels, WARNING indicates failure to following these instructions can result in death, serious injury, or equipment damage.

### Caution

For the purposes of this manual and product labels, CAUTION indicates a potentially hazardous situation which, if not avoided, could result in minor or moderate injury.

These instructions do not purport to cover all details or variations in equipment, nor to provide for every possible contingency to be met in connection with installation, operation or maintenance. Should further information be desired or should particular problems arise which are not covered sufficiently for the purchaser's purposes, the matter should be referred to the local Siemens sales office.

### Do Not Hi-Pot Test SPDs

**Any factory or on-site testing of power distribution equipment that exceeds normal operating voltage such as high-potential insulation testing, or any other tests where the suppression components will be subjected to higher voltage than their rated Maximum Continuous Operating Voltage (MCOV) must be conducted with the SPD disconnected from the power source. For 4-wire systems, the neutral connection at the SPD must also be disconnected prior to performing high-potential testing and then reconnected after test completion.**

**Failure to disconnect SPD and associated components during elevated voltage testing will damage the SPD and will void the warranty.**

### Limited Warranty

Siemens warrants its AC Panel protection products against defective workmanship and materials for 10 years. Liability is limited to the repair or replacement of the defective product at Siemens' option. A Return Material Authorization number (RA#) must be given by the company prior to the return of any product. Returned products must be sent to the factory with the transportation charges prepaid. In addition, the company also warrants unlimited replacement of modular and component parts within the warranty period previously described.

The company specifically disclaims all other warranties, expressed or implied. Additionally, the company is not be responsible for incidental or consequential damages resulting from any defect in any product or component thereof.

The sales contract contains the entire obligation of Siemens. This instruction manual shall not become part of or modify any prior existing agreement, commitment or relationship.

### Unpacking and Preliminary Inspection

Inspect the entire shipping container for damage or signs of mishandling before unpacking the unit. Remove the packing material and further inspect the unit for any obvious shipping damages. If any damage was found and is a result of shipping or handling, immediately file a claim with the shipping company and forward a copy to your local Siemens sales office.

### Storage

The unit should be stored in a clean, dry environment. Storage temperature is -55° C (-67° F) to +85° C (+185° F). Avoid exposing the unit to areas of high condensation. All of the packaging materials should be left intact until the unit is ready for installation. If the unit has been stored for an extended period of time, it may be necessary to clean the unit and make a complete inspection of the unit prior to installing and placing into service.

## Industry Standards Changes - 2009

UL 1449 Third Edition and 2008 NEC® Article 285 generated substantial changes.

- The term TVSS changed to SPD
- Types 1, 2, 3 & 4 SPDs are created
- UL 1449 clamping voltage performance testing changed from 500A to 3,000A
- UL 1449 added new Nominal Discharge Current testing (I nominal, or In), which consists of more rigorous duty-cycle testing

The SPD Type category is important to understand before installing any SPD. Type 1 and 2 SPDs are fully UL Listed devices whereas Type 4 SPDs are UL Recognized devices.

**Type 1** – Installed on line or load side of the Main Overcurrent Protection (OCP), similar to obsolete products known as Secondary Surge Arrestors, except now includes rigorous safety testing. Includes all OCP & safety disconnectors inside the SPD.

**Type 2** – Installed on load side of the Main OCP, similar to previous products known as TVSS. May or may not require external OCP.

**Type 3** – Point of Utilization, direct plug in type devices, surge strips, etc. These devices are intended for installation 10 meters from the panel (rationale based on IEEE Cat. A location).

**Type 4** – Surge suppression components, could be a basic component or a complete module. Type 4 components can be tested for Type 1, Type 2 or Type 3 applications.

Figure 1: SPD Types

### 2008 NEC Art 285 & UL 1449-3

SPD Types: Types 1, 2, 3, & 4

Based on Location within electrical distribution system  
(also coincides with ANSI/IEEE C62.41.2 - 2002 Categories C, B & A)

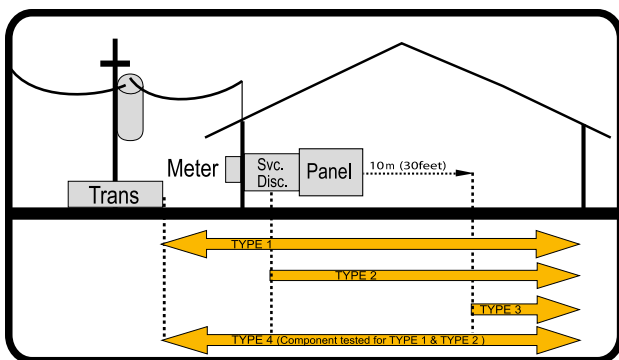

## General Information

### Product Family Outline

TPS3 12 – Single Module in enclosure

TPS3 15 – Two Modules in enclosure

Each is available with Standard modes (most common) or discrete 10-modes (specific application). For example, TPS3 12 is a SPD in an enclosure with Standard modes of protection; TPS3 L12 is a SPD with an enclosure having discrete ten mode protection.

The TPS3 12 & TPS3 15 families are intended for use as a Type 1 external mount SPD. See Model Number Decoder in Table 1 (page 3).

### Type 1 SPD

Type 1 SPDs include internal overcurrent protection and have been evaluated by UL to more stringent requirements. Type 1 SPDs are suitable for installation on the line side or load side of the service disconnect overcurrent device. Type 1 SPDs may be used in Type 2 applications.

### Internal Protection

This device features internal overcurrent and overtemperature protection that will disconnect effected surge suppression components at the end of their useful life, but will maintain power to the load – now unprotected. If this situation is undesirable for the application, follow these instructions for servicing or replacing the device.

### Service Guidelines

Service of this unit consists of replacing the internal module(s), disconnect switch (if equipped) and/or display assembly.

There are no user-serviceable parts inside the replaceable module. Do not attempt to disassemble the module as it stores charge.

### Simplified Explanation of Operation

As SPDs sense overvoltage, they create a momentary internal short circuit, thereby redirecting harmful surge energy to earth ground. SPDs are capable of repeating this function repeatedly. For optimum protection, staged surge suppression should be implemented at the service entrance and all other distribution or panelboard locations feeding sensitive equipment.

Table 1: Model Number Decoder

TPS SERIES DESCRIPTION	
TPS3 12	Externally mounted SPD, single module in enclosure, standard modes of protection
TPS3 L12	Externally mounted SPD, single module in enclosure, 10 modes of protection
TPS3 15	Externally mounted SPD, dual replaceable modules in enclosure, standard modes of protection
TPS3 L15	Externally mounted SPD, dual replaceable modules in enclosure, 10 modes of protection

AVAILABLE VOLTAGES				
VOLTAGE CODES	TPS3 12	TPS3 L12	TPS3 15	TPS3 L15
A = 240/120V Split Phase 1Ø, 3W Plus Grnd (Fig 1)	√	√	√	√
B = 240/120V 3Ø, High Leg Delta (B High) (Fig 3)	√	√	√	√
C = 208Y/120V 3Ø, 4W Plus Grnd (Fig 2)	√	√	√	√
D = 240V 3Ø, 3W Plus Grnd (Fig4)	√		√	
E = 480Y/277V 3Ø, 4W Plus Grnd (Fig 2)	√	√	√	√
F = 480V 3Ø, 3W Plus Grnd (Fig 4)	√		√	
G = 600V 3Ø, 3W Plus Grnd (Fig 4)	√		√	
K = 380Y/220V 3Ø, 4W Plus Grnd (Fig 2)	√	√	√	√
L = 600Y/347V 3Ø, 4W Plus Grnd (Fig 2)	√		√	
S = 400Y/230V 3Ø, 4W Plus Grnd (Fig 2)	√	√	√	√

AVAILABLE SURGE CURRENT RATING				
SURGE CURRENT RATING	TPS3 12	TPS3 L12	TPS3 15	TPS3 L15
10 = 100kA per phase	√			
15 = 150kA per phase	√	√		√
20 = 200kA per phase	√			
25 = 250kA per phase	√			
30 = 300kA per phase	√	√		√
40 = 400kA per phase	√			
45 = 450kA per phase		√		
50 = 500kA per phase	√			
60 = 600kA per phase			√	√
80 = 800kA per phase			√	
90 = 900kA per phase				√
1K = 1000kA per phase			√	

AVAILABLE OPTIONS (When Option is Not Selected Include a "0" in the Field)				
OPTION CODE / DESCRIPTION	TPS3 12	TPS3 L12	TPS3 15	TPS3 L15
0 = Standard NEMA 1/12/3R/04 enclosure	√	√	√	√
V = NEMA 4X Non-metallic enclosure	√	√	√	√
S = NEMA 4X Stainless Steel enclosure	√	√	√	√
F = NEMA 1 Flush Mount enclosure	√	√	√	√
P = NEAM 1 Screwcover Pullbox enclosure	√	√	√	√
X = Surge Counter	√	√	√	√
D = Internal Rotary Disconnect Switch	√	√		
T = Thru-door Rotary Disconnect Switch	√	√	√	√

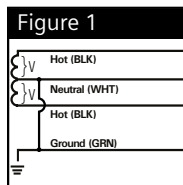

SPLIT  
2 Hots, 1 Neu, 1 Grnd

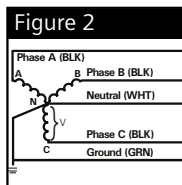

WYE  
3 Hots, 1 Neu, 1 Grnd

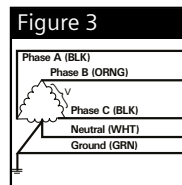

HI-LEG DELTA (B High)  
3 Hots, (B HIGH),  
1 Neu, 1 Grnd

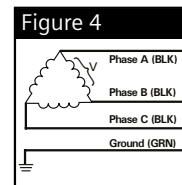

DELTA & HRG WYE  
3 Hots, 1 Grnd

## Parallel Connection

This is a Parallel connected SPD – not series connected. As outlined previously, an SPD ‘drains off’ excessive voltage from an electrical system. Because of parallel connection, installation of the SPD reasonably near the equipment to be protected is satisfactory.

Tip: It is very important that wiring leads be configured as short & straight as possible. Avoid long leads. Avoid sharp bends. Route SPD conductors in the same conduit. Leads do not have to be sized for the entire load – this SPD is parallel connected, not series connected. As a generalization, 6 AWG is satisfactory.

Figure 2: Typical Parallel Connected SPD on Electrical Panel

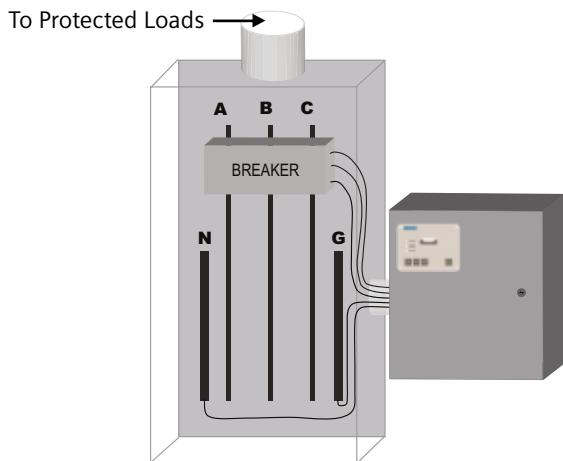

## Precautionary Statement Regarding SPDs on Ungrounded Systems

Caution – Ungrounded systems are inherently unstable and can product excessively high line-to-ground voltages during certain fault conditions. During these fault conditions, any electrical equipment including an SPD, may be subjected to voltages which exceed their designed ratings. This information is being provided to the user so that an informed decision can be made before installing any electrical equipment on an ungrounded power system.

## Cascade Surge Protection

For optimum surge protection, cascade or staged surge suppression should be implemented at the service entrance and downstream locations as appropriate. Known or expected surge sources, as well as sensitive loads, should also have localized surge suppression. For interconnected electronic loads (data cabling), SPDs should also be utilized to protect the devices on either end of the interconnecting data cables.

## Unpacking & Preliminary Inspection

Inspect the entire shipping container for damage or signs of mishandling. Remove the packing materials and further inspect the unit for any obvious shipping damages.

If any damage was found and is a result of shipping or handling, immediately file a claim with the shipping company and forward a copy to Siemens TPS Tech Support.

## Pre-Installation and Planning

### Operating Environment

The standard unit uses a Type 1/12/3R/4 enclosure. Non-metallic polycarbonate 4X, stainless steel and Type 1 flush-mount or pull box enclosures are available as options. Before installing, ensure that your enclosure type and application are appropriate per NEMA 250 with regard to moisture, dirt, excessive dust, flammable materials or atmospheres, corrosive vapors, etc. Please consult factory if enclosure needs changed.

This SPD is designed to operate in an ambient temperature range of -40°C (-40°F) to +60°C (+140°F) with a relative humidity of 0% to 95% (non-condensing). Excessive temperature may inadvertently operate internal thermal overtemperature protectors.

On rare occasions in high temperature climates, SPDs inside clear-cover polycarbonate enclosures have experienced internal temperatures exceeding 200°F (94°C). We recommend positioning the unit so that the clear front avoids direct summer sunlight by shading or not facing west.

### Line Side versus Load Side Installation

The TPS3 12 & TPS3 15 family SPDs are tested and qualified as Type 1 SPDs per UL 1449 Third Edition and 2008 NEC. This SPD can be installed on the Line Side of the service overcurrent device per 2008 NEC Article 285. Type 1 SPDs may also be installed in Type 2 applications. As a generalization, it is more practical to install as Type 2 on load side of main overcurrent device for maintenance reasons. Such installations would be similar to traditional SPD installations. (Note: cUL models are Type 2 due to different cUL criteria.)

There may be circumstances where Line Side installation is desirable. Follow all applicable Code requirements for Line Side installation. We generally recommend that the SPD be installed with a disconnecting mechanism for servicing purposes.

Tip: Siemens TPS offers an optional Disconnect Switch that has been UL evaluated as part of the SPD. This includes SCCR and Line Side suitability. If you do not use the disconnect option, select a disconnect switch rated for line side (UL 98) having appropriate SCCR rating including any required overcurrent protection. This may be more time consuming and expensive than anticipated. The optional Disconnect Switch is fully engineered and almost certainly easier, smaller and less expensive. Please contact Siemens TPS Tech Support as appropriate.

### Audible Noise

SPD background noise is negligible or non-existent, and does not restrict the location of installation.

### Mounting, Dimensions, and Weight

The TPS3 12 & TPS3 15 series include enclosures and are intended for wall mounting. See Table 2 for details.

Table 2: Weight & Dimensions

TPS3 12	H/W/D (in./mm.)	Weight
Standard Enclosure	12" x 12" x 7.5" (305x305x191)	22 lbs (10 kg)
Standard Enclosure, 400 – 500kA with Opt. Disc. Switch	16" x 14" x 6" (496x356x152)	32 lbs (14.5 kg)
4X Non-Metallic	14" x 12" x 7" (356x305x178)	14 lbs (6.4 kg)
4X Non-Metallic, 400 – 500kA with Opt. Disc. Switch	16" x 14" x 7" (496x356x178)	21 lbs (9.5 kg)
4X Stainless	12" x 12" x 7" (305x305x178)	24 lbs (10.9 kg)
4X Stainless, 400 – 500kA with Opt. Disc. Switch	16" x 14" x 6" (496x356x152)	33 lbs (15 kg)
<b>Pullbox &amp; Flush mount</b>	12" x 12" x 6" (305x305x152)	21 lbs (9.5 kg)
Pullbox & Flush mount, 400 – 500kA with Opt. Disc. Switch	16" x 14" x 6" (496x356x152)	29 lbs (13.2 kg)
TPS3 15 Internal disconnect switch standard		
Standard Enclosure	20" x 20" x 7.5" (508x508x191)	52 lbs (23.6 kg)
4X Non-Metallic	24" x 24" x 8" (610x610x203)	52 lbs (23.6 kg)
4X Stainless	20" x 20" x 7" (508x508x178)	53 lbs (24 kg)
Pullbox & Flush mount	20" x 20" x 6" (508x508x152)	53 lbs (24 kg)

**Service Clearance**

Service clearance is needed at the front of the unit; 36 inches minimum is the required distance for clearance pursuant to the NEC®.

**Lead Lengths & Maximizing SPD Performance**

SPDs must be located as close to the circuit as possible to minimize parasitic losses. Surges are high current, high frequency events that cause substantial voltage drops across conductors. This hurts SPD performance. Use the shortest & straightest possible leads. Pre-Plan installations and ensure that nearest breaker positions are used. If new construction, adjust breaker locations as appropriate.

Tip: In surge applications, voltage drops might be 100-150V per foot. These voltage drops add to clamping voltage, thus hurting performance. Make every effort to keep leads short and straight.

Tip: As distribution gear becomes larger, shorter leads are more difficult to accomplish. When longer leads are unavoidable, gently twist leads together (one to two twists per foot), or tie-wrap leads together.

**Shortest Leads Possible**

- Leads must be as short and straight as possible - See NEC Art. 285.12
- No long leads
- No sharp bends
- No wire nuts
- How short is short enough? As short as you can make it.
- How long is too long? If anyone else can make it shorter.

**Overcurrent Protection**

SPDs draw very little current under normal conditions and conduct for a brief duration upon encountering a transient surge current. This SPD contain internal overcurrent and overtemperature protection to protect against abnormal voltage conditions.

Supplemental overcurrent protection is not required to protect this SPD. However, connecting conductors require protection in Type 2 or 4 applications. Follow applicable codes.

**Voltage Rating**

Before installing SPD, verify that it has the same voltage rating as the power distribution system. Compare the SPD's nameplate voltage or model number and ensure that SPD configuration matches the intended power source. See Table 1.

The specifier or the user of the device should be familiar with the configuration and arrangement of the power distribution system in which any SPD is to be installed. The system configuration of any power distribution system is based strictly on how the secondary windings of the transformer supplying the service entrance main or load are configured. This includes whether or not the transformer windings are referenced to earth via a grounding conductor. The system configuration is not based on how any specific load or equipment is connected to a particular power distribution system.

480V System Example: SPDs should be installed per the electrical system, not per a load or motor's wiring connection. For example, a 480V three phase motor might appear to be connected as a 480V Delta. In actuality, the serving distribution system might be a 480Y/277V grounded Wye, with or without a neutral pulled to the motor or MCC. The system is still a 480Y/277V Wye, even though the load is connected as a Delta. A grounded Wye has a defined reference to ground (i.e., neutral is bonded to ground). Some Delta systems are ungrounded, which have no reference to ground and are known to become unstable in certain situations. Such instability can cause line to ground voltage fluctuations that may prematurely fail SPDs. For this reason, the NEC Article 285 has placed SPD restrictions on ungrounded systems. As generalizations, SPDs for ungrounded systems can be installed on grounded systems with a clamping performance penalty. However, SPDs for grounded systems installed on ungrounded systems are almost certainly destined for premature failure. Contact Tech Support at 1.888.333.3545 for further information.

**Circuit Breaker and Disconnect Switch**

The TPS3 12 and TPS3 15 family SPDs are tested and qualified as a Type 1 SPD per UL 1449 Third Edition and 2008 NEC. This SPD can be installed on the line side of the service overcurrent device per 2008 NEC Article 285. As a generalization, it is more practical to install on load side of main overcurrent device for maintenance reasons.

When connected on load side of main disconnect, a 60A circuit breaker is recommended. The circuit breaker is the intended disconnect switch and provides short circuit protection to the connecting conductors. These SPDs have internal overload protection elements within the product. A breaker or disconnect is not required for the SPD's overcurrent protection. These SPDs have demonstrated 200kA Short Circuit Current Ratings (SCCRs). 120V & 120/240V models have demonstrated 100kA SCCR. Refer to label on unit.



## Terminals

Terminals will accept 14 - 2 AWG conductor and are provided for line (phase), neutral (if used), and equipment safety ground connections. 8 AWG is the minimum recommended wire size because UL testing and evaluation was performed using 8 AWG.

## Wire Size and Installation Torque

This is a parallel-connected SPD; it is not series-connected. The size of the SPD wiring is independent of the ampere rating of the protected circuit. Recommended wire is 6 AWG for phase, neutral and ground connections. Torque connections to 18 inch-pounds. Conductor length should be as short as possible.

If other wire sizes are used, all conductors must be the same gauge. Note that larger conductor might appear to be beneficial. However, large conductor tends to have the same inductance as smaller conductor, thus netting limited improvement in exchange for being more difficult to work with.

Terminals accept 14 - 2 AWG conductor with 6 AWG being preferred. Coordinate conductor size and overcurrent protection per applicable codes.

If equipped, Disconnect Switch will accept 6 AWG to 1/0 AWG, with 6 AWG preferred. Torque connections to 18 inch-pounds. Do Not over-torque connections on Disconnect Switch as they will fail upon overtightening and will not be covered by warranty.

## System Grounding

An equipment grounding conductor must be used on all electrical circuits connected to the SPD.

For the best performance, use a single point ground system where the service entrance grounding electrode system is connected to and bonded to building steel, metallic piping, driven rods, etc. (NEC and IEEE Std 142-2007 are appropriate standards).

For sensitive electronics and computer systems, ground impedance should be as low as possible. When metallic raceway is used as an additional grounding conductor, an insulated grounding conductor should be run inside the raceway and sized per the NEC. Adequate electrical continuity must be maintained at all raceway connections. Do not use isolating bushings to interrupt a metallic raceway run.

A separate isolated ground for the SPD may isolate the SPD from the rest of the electrical system, thus decreasing performance. Ensure grounding system meets NEC. Proper equipment connections to grounding system and ground grid continuity should be verified via inspections and tested on a regular basis as part of a comprehensive electrical maintenance program.

On 4-Wire Power Systems, neutral to ground bonding (Main Bonding Jumper) must be installed per the NEC<sup>®</sup>. Failure to do so WILL damage SPDs.

## NEMA 3R Drain Holes for Standard Steel Enclosure

In order to maintain a UL 3R rating, two 0.25" (6mm) holes must be drilled in opposite corners of the bottom surface of the enclosure. Take care to not damage internal SPD components. Remove any drilling remnants. (Do not perform on other enclosures or ratings.)

Figure 3: NEMA 3R Drain Holes

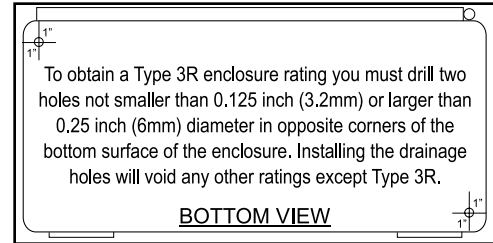

## Module Rotation Feature

Installation lead wire length must be minimized because longer leads hurt performance. Lead length may be reduced by rotating the module inside the enclosure. SPD ships with terminals pointing down. If installation lends itself toward other orientation, the module's aluminum backplane can be unscrewed and reoriented. For example, if leads enter from top, rotate module assembly such that leads are shortest. Be careful with ribbon cable connector and take care to retighten screws & secure ribbon cable. Mounting screws are in four corners. Rectangular enclosures may be rotated up or down only.

Figure 7: Rotating Module

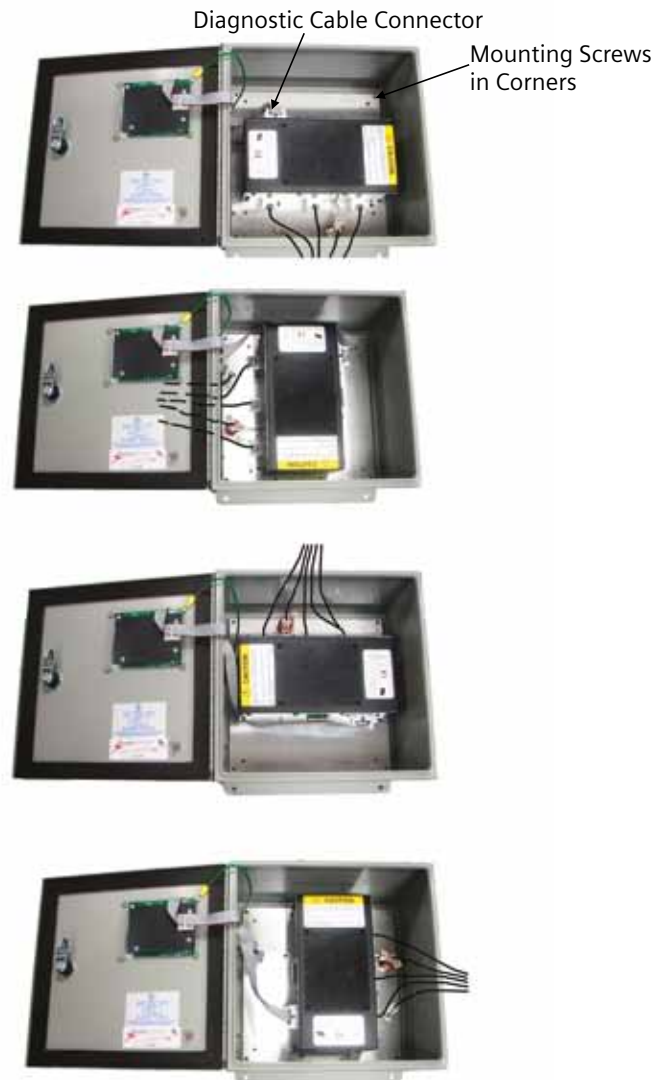

## Optional Flush Mount Installation Considerations

The TPS3 12 and TPS3 15 are approximately 6" deep. The unit will not mount flush unless there is at least 6" of depth clearance. The TPS3 12 and TPS3 15 are not designed to mount flush on a typical 2 x 4 stud wall.

**Back Flange Mounting:** Mount as close as possible to protected panel. Create a wall opening slightly larger than 12" high by 12" wide. See drawing. Configure a robust backing plate inside the wall cavity 6" from the wall face such that the TPS will be supported from its back. Note the mounting holes on the back flange. Also note that the TPS weighs 25lbs. Be careful not to drop the unit into the wall. Configure electrical conductor and conduit connections consistent with Installation Instructions beginning on page 4. Carefully reattach ribbon cables and faceplate/cover prior to energizing and testing unit.

The TPS3 12 and TPS3 15 Series are designed for back flange mounting only. Do not attempt to install the TPS such that its weight is supported by the front flange. The four mounting holes on the front flange are intended to secure the front flange to the outer wall surface.

### Retro-fit to an Existing Panel with No Available Breaker Positions

These can be difficult with limited options. Follow all applicable Codes:

- Consider consolidating loads in a manner that might free breaker positions.
- A ten foot tap rule in NEC 240.21(B)(1) allows tapping the bus as long as the tap conductors are rated at least 10% of the ampacity of the panel. This works well if the panel is about 600A or less: Tap the bus, run short 6 AWG leads to the SPD. An SPD with a Disconnect Switch allows for easier SPD servicing in the future. If the panel starts getting large (>800A), then the conductor size increases, which may also become too large to fit into the SPD lugs or too cumbersome to work with. In that case, consider tapping the bus per NEC 240.21(B)(1). Run appropriate size conductors to a safety switch fused to 60A. Mount the SPD immediately adjacent to the safety switch. Connect SPD to the load side of the safety switch with 6 AWG. Keep all leads as short as possible.
- Install on Line Side by taking advantage of Type 1 SPD rating. Consider an SPD with a Disconnect Switch.

Figure 6: Flush Mount Installation

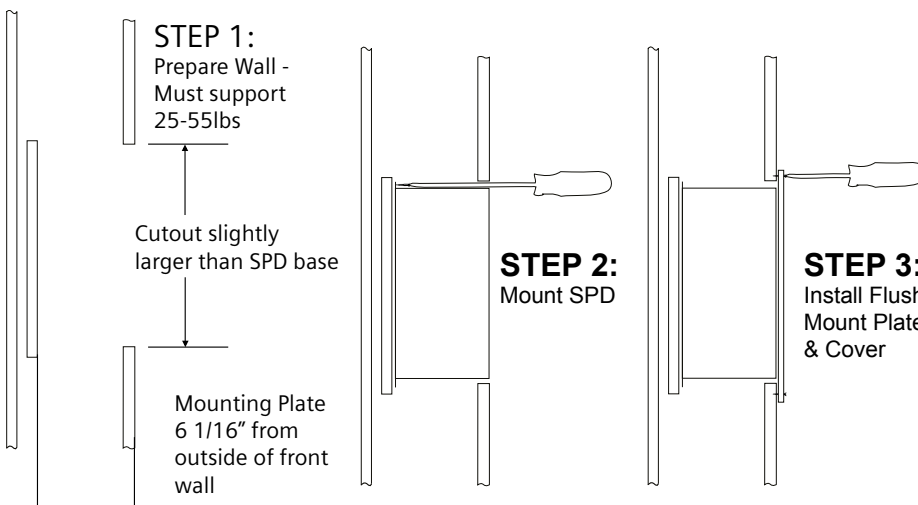

## Disconnect Switch (Opt. on TPS3 12, Std. on TPS3 15)

The disconnect switch provides manual disconnection means for phase conductors and the neutral conductor. Ground is not switched.

Special care should be taken while pre-planning installation to ensure that leads are as short as possible. Most TPS3 12's & TPS3 15's in 'square' enclosures have backplanes that can be removed and repositioned to reduce leads. See Figure 6. (Models with rectangular enclosures may be repositioned by inverting only.) (Excludes thru-door handle options.)

**There is limited working space around the Disconnect Switch. This is a consequence of reducing internal size and lead lengths. Please be patient.**

Disconnect switch will accept 6 AWG to 1/0 AWG, with 6 AWG preferred. Torque connections to 18 inch-pounds. Over-torquing connections will fail the disconnect switch and will not be covered by warranty.

The disconnect switch is mounted on DIN-rail. It may be removed by gently pulling out the mounting tab at the bottom of the switch assembly.

Siemens TPS is one of few SPD manufacturers that offer Disconnect Switches available as a fully UL qualified option. The Short Circuit Current Rating posted on the UL label of the SPD includes the Disconnect Switch and supercedes any rating on the individual Disconnect Switch. When used in a Type 1 line-side application, the SPD including its Disconnect Switch has been UL tested and approved. Further evaluation is not required by UL, nor is a separate UL 98 rated switch required.

### UL 1283 required language concerning the installation of EMI Filters

a) An insulated grounding conductor that is identical in size and insulation material and thickness to the grounded and ungrounded circuit supply conductors, except that it is green with or without one or more yellow stripes, is to be installed as part of the circuit that supplies the filter. Reference should be made to Table 250-122 of the National Electrical Code regarding the appropriate size of the grounding conductor.

b) The grounding conductor mentioned in item a is to be grounded to earth at the service equipment or other acceptable building earth ground such as the building frame in the case of a high-rise steel-frame structure.

c) Any attachment-plug receptacles in the vicinity of the filter are to be of a grounding type, and the grounding conductors serving these receptacles are to be connected to earth ground at the service equipment or other acceptable building earth ground such as the building frame in the case of a high-rise steel-frame structure.

d) Pressure terminal or pressure splicing connectors and soldering lugs used in the installation of the filter shall be identified as being suitable for the material of the conductors. Conductors of dissimilar metals shall not be intermixed in a terminal or splicing connector where physical contact occurs between dissimilar conductors unless the device is identified for the purpose and conditions of use.

**⚠ CAUTION**

**CONDUCTING DIELECTRIC AND/OR HI-POTENTIAL TESTING WILL CAUSE INTERNAL DAMAGE TO TPS3 UNIT.**

Do not perform dielectric or high potential tests with the TPS3 unit installed.

**⚠ DANGER**

**Hazardous voltage. Will cause death or serious injury.**

Keep Out.  
Qualified personnel only.  
Disconnect and lock off all power before working on this equipment.

## TPS3 12 and TPS3 15 Installation Instructions

### PRE-PLAN INSTALLATION TO ACCOMPLISH THE FOLLOWING:

- Meet all National and Local codes (NEC® Article 285 addresses SPDs)
- Mount SPD as close to panel or equipment as possible to keep leads short
- Ensure leads are as short and straight as possible, including neutral and ground. Consider a breaker position that is closest to the SPD and the panel's neutral & ground
- Suggested breaker & conductor size is 60A-30A with 6 AWG
- Make sure system is grounded per NEC® and clear of faults before energizing SPD.

### CERTAIN OPTIONS OR IMPLEMENTATIONS REQUIRE EXTRA CONSIDERATION. SEE APPROPRIATE SECTIONS WITHIN THIS MANUAL:

- Line Side Installation (page 4)
- Disconnect Switch Option (page 9)
- Flush Mount Option (page 9)
- Retro-fit where no breaker positions are available (page 9)
- NEMA 3R drain holes (page 7)

Figure 3: Panel Installation

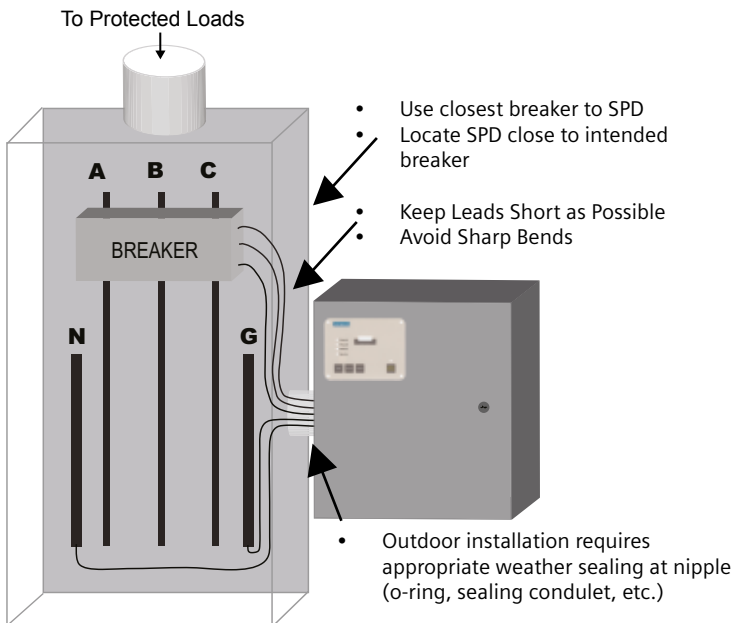

Use a voltmeter to check all voltages to ensure correct SPD

If SPD has Dry Contact, Remote Monitoring or Remote Display, pre-plan their installation

Remove power for panel. Confirm panel is deenergized.

Identify connection/breaker location and SPD location.

Make sure leads are short. Reducing inches matters.

Installation Tips: SPD module is mounted on backplane within its enclosure. In many cases, the backplane assembly can be unbolted and rotated in two or four directions to yield shortest leads. See Figure 7. Carefully disconnect ribbon cable(s) and unbolt backplane assembly. Various configurations have limited work space. Please be patient. Installation may be easier if disconnect switch is temporarily removed from DIN-rail, or module/backplane is temporarily removed.

Remove an appropriately sized knockout from panel. Create an appropriately sized and located hole in the SPD enclosure.

Mount SPD. Connect to equipment using an approved wiring method, including seals appropriate for the enclosure rating. Carefully reinstall backplane or disconnect switch as appropriate.

Connect conductors as appropriate – short and straight as possible (Note that Hi-Legs are Phase B)

Label or mark conductors as appropriate (neutral: white, ground: green, energized: black, hi-leg: orange)

Make sure system is bonded per NEC® and is clear of hazards or faults before energizing (N-G bonding not per NEC® will fail SPDs: #1 cause of SPD failures)

Energize and confirm proper operation of indicators and/or options.

Figure 4: Electrical Drawings

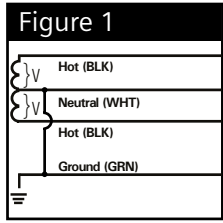

SPLIT  
2 Hots, 1 Neu, 1 Grnd

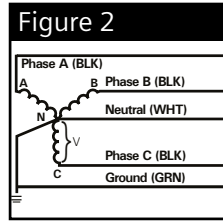

WYE  
3 Hots, 1 Neu, 1 Grnd

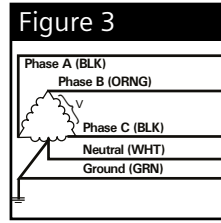

HI-LEG DELTA (B High)  
3 Hots, (B HIGH),  
1 Neu, 1 Grnd

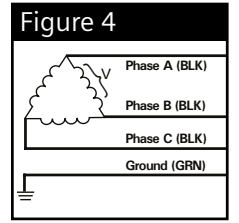

DELTA & HRG WYE  
3 Hots, 1 Grnd

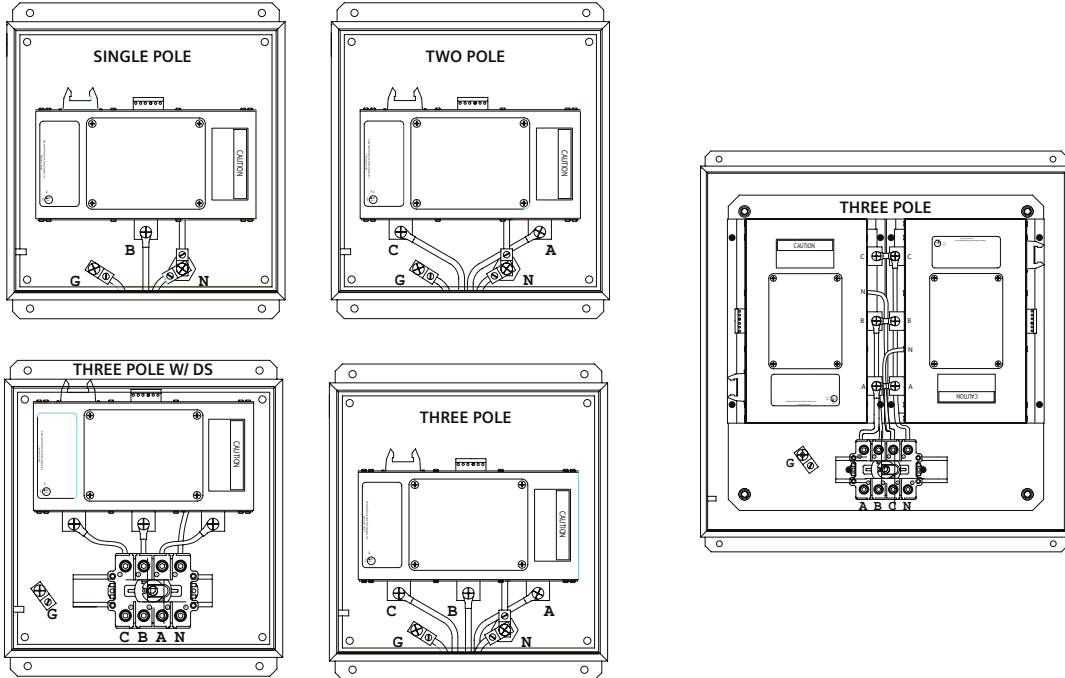
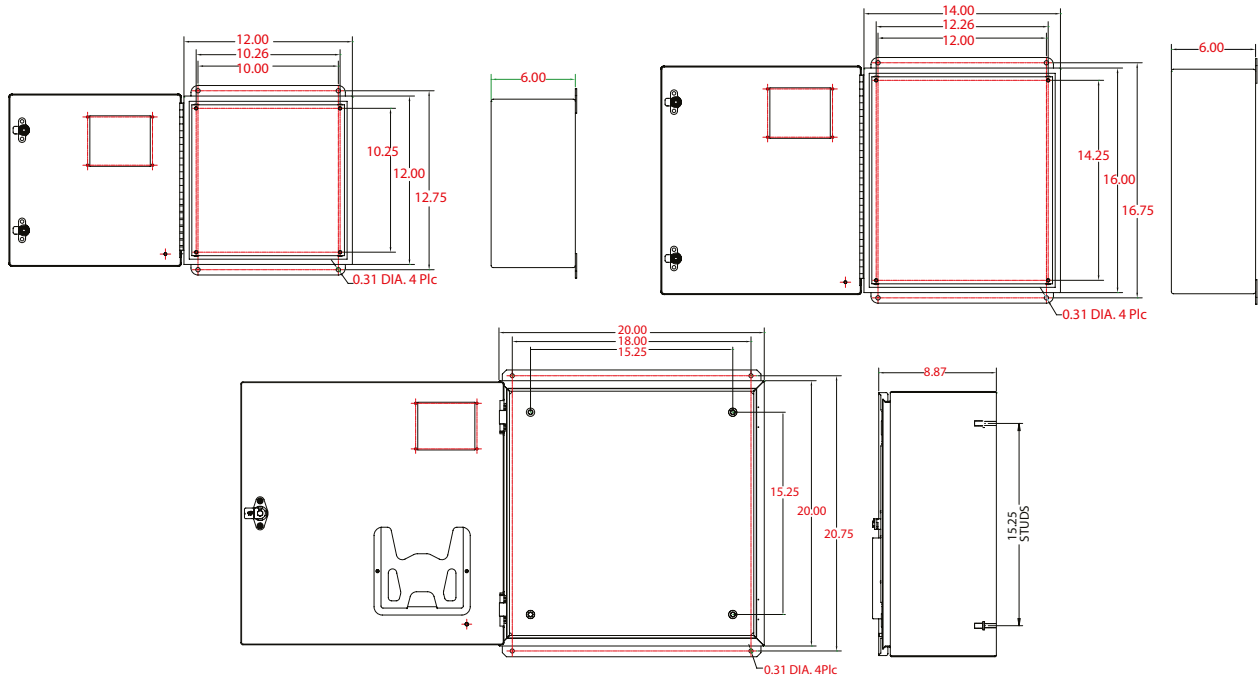

Figure 5: Mechanical Drawings

Consult factory for more options at 1.888.333.3545



## Operation

Figure 8: Horizontal Display (Shown with Surge Counter)

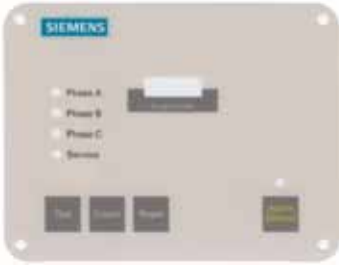

Figure 9: Vertical Display (Shown with Surge Counter)



**Phase A, B & C:** Green LED indicators—one per phase. Green is good. Extinguished green LED indicates loss of protection. Every suppression element in this SPD is monitored. N-G suppression element monitoring is logic-connected to Phase A.

**Service LED (red):** LED illuminates in the event of problems. This indicator is logic-connected to the Phase LEDs. Should a Phase LED go out the Service LED will illuminate and the Audible Alarm will sound.

**Test:** Tests red Service LED and Audible Alarm, and changes state of Dry Contacts.

**Alarm Silence:** turns Audible Alarm off. (Alarm is deactivated when the Silence LED is illuminated.)

**Surge Counter Count:** (if equipped) Increments optional surge counter by one (+1)

**Surge Counter Reset:** (if equipped) Resets optional surge counter to zero (0)

## Diagnostic Display Panel

All indicators and controls are located on the diagnostic panel. The diagnostic panel is located on the front of the SPD enclosure or behind the door on certain optional enclosures. Each phase features a Green LED indicator. Green LEDs indicate correct operation.

*If an inoperative condition were to occur, the built-in audible alarm will sound and the red **Service** LED will illuminate. This indicates that the unit needs evaluation by a qualified electrician or technician. Until a qualified person evaluates the unit, press **Alarm Silence** to silence the alarm. (The LED above **Alarm Silence** illuminates when the alarm is deactivated. Normal operation occurs with the **Alarm Silence** LED extinguished.) The red Service LED will remain illuminated even though the Audible Alarm has been silenced. **Test** tests the red Service LED, the Audible Alarm, and changes the state of Dry Contacts (if equipped).*

If LEDs are illuminated in a manner that suggests contradictory information, there may be an internal logic problem and the unit needs replaced. If none of the LEDs are illuminated, the unit may not be installed correctly. For troubleshooting assistance, please contact Siemens TPS Tech Support at 888.333.3545.

## Surge Counter Option

The surge counter registers the number of transient overvoltages on all L-N and L-G modes since the counter was last reset. The counter is inductively coupled from each mode of protection. It increments upon significant current change in a short time period (large di/dt).

The surge counter includes **Test** and **Reset** buttons on the touchpad display. Pressing **Test** adds one count. Pressing **Reset** clears the counter's memory and sets the display to zero.

The counter includes an Eprom memory chip to store the surge count in the event of a power loss. The Eprom requires no maintenance giving it an advantage over replaceable batteries. The surge counter display will be blank if all power is lost to the SPD but will retain the last count shown on the display once power is returned.

## Dry Contact Option

Two sets of Form C dry contacts are included with the Dry Contact option. Dry Contacts change state during inoperative conditions, including loss of power. Any status change can be monitored elsewhere via Dry Contacts.

A Terminal Block includes two sets of Normally Open (N.O.) and Normally Closed (N.C) contacts. Both sets of contacts operate the same. This is shown in Figure 10.

Figure 10: Dry Contact Connection Configuration

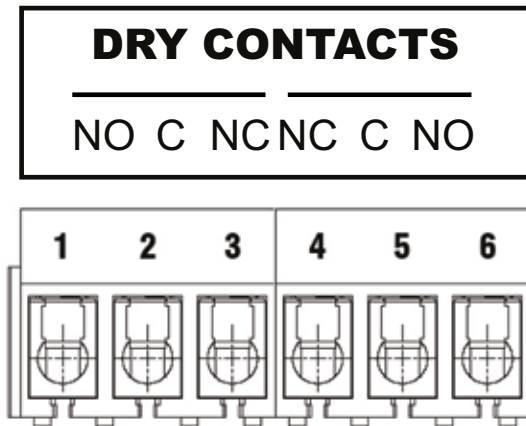

A typical application using a Normally Closed configuration would connect to one set of the N.C. and Common terminals. During an inoperative condition, the SPDs dry contact would change state from Normally Closed to open. The Normally Closed configuration is recommended because it will detect a wiring defect, such as cut wire(s), where N.O. will not.

Please note: Dry Contacts are designed for low voltage or control signals only.

- Maximum switching current is 5A
- Maximum switching voltage is 240V DC or AC.
- Higher energy applications require additional relay implementation outside the SPD.

An optional Remote Monitor accessory is available to provide visual and audible status. The Remote Monitor will consume one of the two sets of Dry Contacts.

### Remote Monitor Accessory

A Remote Monitor—Model No. RMSIE (ordered separately) is available for remote annunciation. It requires a standalone 120V power source (wall plug transformer) and uses one set of Form C dry contacts. The Remote Monitor can be configured to monitor several SPDs simultaneously. Installation is detailed in a separate document. Contact factory as appropriate.

## Maintenance

SPDs require minimal maintenance. Periodic inspection of diagnostic LED indicators ensures proper operation. Clean SPD as appropriate.

### Troubleshooting & Service

Please contact TPS Technical Support at 1.888.333.3545 for service related issues.

Quality SPDs are designed and tested to withstand severe duty. However, there are various electrical anomalies against which SPDs cannot protect. These are generally Sustained Overvoltages also known as Temporary Overvoltages (TOVs). In this context, Sustained Overvoltages may be only a few cycles. Failed SPDs tend to be symptoms, not root causes. There may be larger issues at play. Regardless of cause, SPDs attempt to protect their load until failure.

Bonding or reference to ground problems are the root cause of many SPD problems. If the SPD shows problems on startup, there is reasonable chance of bonding/grounding/misapplication issue. Such problems permanently damage the SPD. If not corrected, SPD problems will reoccur.

Tip: Visually confirm N-G bonding. Be aware that a voltmeter measuring N-G can be misleading. For example, N-G voltage could read 0V because neutral and ground are at the same potential purely by happenstance, not because they are bonded. Visually confirm bonding.

Tip: Experience indicates that regulation-challenged generators can cause Sustained Overvoltages, as well as ungrounded generators, and/or usual load transfer systems.

### Module Replacement & Service

The module(s) is field replaceable. Deenergize SPD, confirm with appropriate measurement equipment and discharge internal capacitance to ground. Mark locations and carefully disconnect diagnostic cables, dry contact connections, phase conductors, unplug parallel connections on TPS3 15 models, etc. Depending on model, module may be bolted to backplane or the backplane may be part of the module assembly. Remove module/backplane. Reinstall in reverse order.

There are no user serviceable parts inside the module. Disassembly is not permitted.

Modules may be returned to the factory for factory service, qualification and return. Please contact Siemens TPS Tech Support at 888.333.3545 for assistance.

## Display Replacement

The display is field replaceable. Deenergize SPD, confirm with appropriate measurement equipment and discharge internal capacitance to ground. Mark locations and carefully disconnect diagnostic cables, contacts, connecting conductors, etc. Unbolt display and replace. Reinstall in reverse.

Note that a sealing gasket between the display and the enclosure is a key component ensuring weather resistance. Replace the gasket whenever the display is removed.

### TPS3 15 Series with two modules

The TPS3 15 features two redundant modules. One diagnostic display monitors both modules simultaneously via the parallel wire connections between the modules. These connectors plug in to each module, transferring information to internal logic on-board both modules.

If an inoperate condition were to occur, the diagnostic display will indicate a problem via red **Service** LED, audible alarm and dry contact change. Operation is identical to TPS3 12 series.

Each TPS3 15 module includes a red LED above the phase connection tabs, near the inter-module diagnostic wiring. An illuminated red LED indicates the damaged module.

Extra Information: Should one damaged module be removed, the SPD can still function correctly with one module. If the diagnostic display cable was connected to the removed module, reconnect the cable to the other module's quick release connector. The diagnostic display will function correctly. (TPS3 15's with Type 4X or 4S enclosures have the diagnostic display mounted inside the enclosure on the right side module. If this module is removed, the diagnostic display may be moved to the other module. Remove the display's four screws, the display and appropriate internal ribbon cable. Remove blank cover from the remaining module and reassemble in reverse order.)

### Technical Support

1.888.333.3545

Prior to calling Siemens TPS3 Technical Support for assistance or ordering parts, please have the following information available:

TPS3 model number: \_\_\_\_\_

Manufacture date: \_\_\_\_\_

Date of Purchase: \_\_\_\_\_

Your order number: \_\_\_\_\_

### Return Shipment Address:

Siemens - Attn: RA # \_\_\_\_\_

14550 58th Street North

Clearwater, FL 33760



Siemens Industry, Inc.  
Building Technologies Division  
5400 Triangle Parkway  
Norcross, GA 30092  
888-333-3545  
[info.us@siemens.com](mailto:info.us@siemens.com)