

# Robotic Deburring Tool FDB-AC 90 - 180

## Assembly and Operating Manual



## Imprint

### Copyright:

This manual remains the copyrighted property of SCHUNK GmbH & Co. KG. It is solely supplied to our customers and operators of our products and forms part of the product. This documentation may not be duplicated or made accessible to third parties, in particular competitive companies, without our prior permission.

### Technical changes:

We reserve the right to make alterations for the purpose of technical improvement.

**Document number:** 0389513

**Edition:** 01.01 | 10/07/2015 | en

© SCHUNK GmbH & Co. KG

All rights reserved.

Dear customer,

congratulations on choosing a SCHUNK product. By choosing SCHUNK, you have opted for the highest precision, top quality and best service.

You are going to increase the process reliability of your production and achieve best machining results – to the customer's complete satisfaction.

SCHUNK products are inspiring.

Our detailed assembly and operation manual will support you.

Do you have further questions? You may contact us at any time – even after purchase.

Kindest Regards

Yours SCHUNK GmbH & Co. KG

Spann- und Greiftechnik

Bahnhofstr. 106 – 134

D-74348 Lauffen/Neckar

Tel. +49-7133-103-0

Fax +49-7133-103-2399

info@de.schunk.com

www.schunk.com



Reg. No. 003496 QM08



Reg. No. 003496 QM08

## Table of Contents

<b>1</b>	<b>About this manual</b> .....	<b>5</b>
1.1	Warnings.....	5
1.2	Variants.....	6
1.3	Applicable documents .....	6
<b>2</b>	<b>Basic safety notes</b> .....	<b>7</b>
2.1	Intended use.....	7
2.2	Environmental and operating conditions.....	7
2.3	Product safety.....	8
2.4	Personnel qualification.....	8
2.5	Using personal protective equipment.....	8
2.6	Notes on particular risks.....	9
<b>3</b>	<b>Warranty</b> .....	<b>10</b>
<b>4</b>	<b>Scope of delivery</b> .....	<b>10</b>
<b>5</b>	<b>Technical data</b> .....	<b>11</b>
5.1	Technical Specifications.....	11
5.2	Environmental Limitations .....	14
<b>6</b>	<b>Handling, Installation, Storage and Transportation</b> .....	<b>15</b>
6.1	Inspection of Condition when Delivered.....	15
6.2	Unpacking and Handling.....	15
6.3	Installation .....	15
6.3.1	Mounting, Adapter and Interface Plate.....	15
6.3.2	Pneumatics FDB-AC 90.....	17
6.3.3	Pneumatics FDB-AC 180.....	18
6.4	Transportation and Protection during Transportation .....	20
6.5	Storage and Preventive Maintenance during Storage .....	20
<b>7</b>	<b>Operating Instructions</b> .....	<b>21</b>
7.1	General Precautions .....	21
7.2	FDB-AC Working Environment .....	22
7.3	Tool Center Point (TCP) Position .....	23
7.3.1	TCP FDB-AC 90.....	23
7.3.2	TCP FDB-AC 180.....	24
7.4	Operational Considerations .....	25
7.5	Programming .....	25
<b>8</b>	<b>Maintenance</b> .....	<b>27</b>
8.1	Regular Operational Maintenance .....	27

8.1.1	User Serviceable parts FDB-AC 90 .....	28
8.1.2	User Serviceable parts FDB-AC 180 .....	29
8.2	Recommended Inspection and Cleaning Procedure .....	29
8.3	Lubrication .....	31
8.4	Replacement of Burrs.....	32
8.5	Replacement of Other FDB-AC Parts.....	33
8.6	Overhaul .....	33
8.7	Repairs and Spare Parts.....	33
<b>9</b>	<b>Drawings .....</b>	<b>34</b>
9.1	FDB-AC 90 .....	34
9.2	FDB-AC 180 .....	35
<b>10</b>	<b>Translation of original declaration of incorporation .....</b>	<b>36</b>







## 1 About this manual

This instruction is an integral part of the product and contains important information for a safe and proper assembly, commissioning, operation, maintenance and help for easier trouble shooting.

Before using the product, read and note the instructions, especially the chapter "Basic safety notes".

### 1.1 Warnings

To make risks clear, the following signal words and symbols are used for safety notes.

	<p> <b>DANGER</b></p> <p><b>Danger for persons.</b> Non-compliance will inevitably cause irreversible injury or death.</p>
	<p> <b>WARNING</b></p> <p><b>Dangers for persons.</b> Ignoring a safety note like this can lead to irreversible injury and even death.</p>
	<p> <b>CAUTION</b></p> <p><b>Dangers for persons.</b> Non-observance can cause minor injuries.</p>
	<p><b>NOTICE</b></p> <p><b>Material damage</b> Information about avoiding material damage.</p>

## 1.2 Variants

This operating manual applies for the following variations

- Robotic Deburring Tool FDB-AC 90
- Robotic Deburring Tool FDB-AC180

## 1.3 Applicable documents

- General terms of business
- Catalog data sheet of the purchased product

The documents listed here, can be downloaded on our homepage  
**[www.schunk.com](http://www.schunk.com)**

## 2 Basic safety notes

### 2.1 Intended use

The product is to be used only for the deburring of workpieces.

The product is intended for installation on a robot. The requirements of the applicable guidelines must be observed and complied with.

The product may be used only in the context of its defined application parameters.

The product is designed for industrial use.

To use this unit as intended, it is also essential to observe the technical data and installation and operation notes in this manual and to comply with the maintenance intervals.

Use which is not specified as an intended use is for instance when

- the product is used with machines/systems or workpieces that are not designed to be used with the unit.
- the product is operated without protective equipment in accordance to the EC Machinery Directive.
- the statutory safety and accident-prevention regulations and the standards and guidelines valid at the usage site are not observed.

### 2.2 Environmental and operating conditions

- Make sure, that the product may be used only in the context of its defined application parameters ([☞ 5, Page 11](#)).
- Make sure that the environment corresponds to the specifications of the catalog. ([☞ 5.2, Page 14](#)).

## 2.3 Product safety

Dangers arise from the product, if:

- the product is not used in accordance with its intended purpose.
- the product is not installed or maintained properly.
- the safety and installation notes are not observed.

Avoid any manner of working that may interfere with the function and operational safety of the product.

Wear protective equipment.

### NOTE

More information are contained in the relevant chapters.

## 2.4 Personnel qualification

The assembly, initial commissioning, maintenance, and repair of the product may be performed only by trained specialist personnel. Every person called upon by the operator to work on the product must have read and understood the complete assembly and operating manual, especially the chapter "Basic safety notes" ([☞ 2, Page 7](#)). This applies particularly to personnel only used occasionally, such as maintenance personnel.

## 2.5 Using personal protective equipment

When using this product, observe the relevant industrial safety regulations and use the personal protective equipment (PPE) required!

- Use protective gloves, safety shoes and safety goggles..
- Observe safe distances.



## 2.6 Notes on particular risks

- Never use or start the tool without first reading and understanding the Installation and Operation Manual.
- Make sure that the tool is mounted as described in chapter "Mounting ([↗ 6.3.1, Page 15](#)).
- Never use the tool for other purposes than those explicitly described in the Installation and Operation Manual.
- Make sure that the pneumatic control equipment is mounted as described in chapter "Pneumatics FDAB-AC.." ([↗ 6.3.2, Page 17](#)) / ([↗ 6.3.3, Page 18](#))
- Only original spare parts and files/burrs delivered from the tool manufacturer must be used ([↗ 8.7, Page 33](#)).
- Never stand near the tool while it is started and running. If it is necessary to approach the tool while in motion, stand behind appropriate Plexiglass® windows.
- Be aware of rotating parts.
- A barrier to prohibit people from approaching the tool while in operation must secure the installation.
- Be aware of high sound levels. Always use earplugs while working near the tool.
- Provide protective equipment to prevent objects from falling or being ejected, such as processed workpieces, tools, chips, fragments, rejects.
- The danger zone must be surrounded by a safety fence during operation.

### 3 Warranty

If the product is used as intended, the warranty is valid for 24 months from the date of delivery from the production facility under the following conditions:

- Observe the applicable documents ([👉 1.3, Page 6](#))
- Observance of the ambient conditions and operating conditions ([👉 2.2, Page 7](#))
- Observe the mandatory maintenance and lubrication intervals. ([👉 8, Page 27](#))

Parts touching the work piece and wearing parts are not part of the warranty.

### 4 Scope of delivery

The scope of delivery includes

- Robotic Deburring Tool FDB-AC in the ordered model.

## 5 Technical data

### 5.1 Technical Specifications

Motor	Air motor, vane type
Speed	Idle 30.000 RPM, while deburring 18.000–25.000 RPM
Torque	0,4 Nm at lower speeds
Power	250 W at 20,000 RPM
Weight total	FDB-AC 90: 0.5 kg FDB-AC 180: 0.51 kg
Weight, compensation piston with burr	0.05 kg
Compensation (burr float)	Max. $\pm$ 4 mm axial and lateral, $\pm$ 2 mm recommended
Axial force	1 - 25 N, @ supply pressure of 0–3,1 bar
Burr surface speed	7,5 - 10,5 m/s, measured at $\varnothing$ 8mm (halfway between center tip and outer rim)
Air consumption	ca. 6,65 l/s at 5,17 bar line pressure
Sound pressure level	75 dB(A)
Sound pressure value	87 dB(C)
Rotary burrs	1) 90° coned shape, straight fluting. 2) 90° coned shape, spiraled fluting. 3) C2, C5 Carbide Other rotary burr/file qualities on request.
Special tools	Burr changing tool

**Notes about Sound pressure level** All noise emission measurements were taken at a distance of 3 feet from the FDB-AC and at a height of 5 feet from the floor. The FDB-AC was mounted on a laboratory test-bench. No barriers or noise-reduction facilities were used except for exhaust return to an oil-recovery-unit located beneath the test-bench. A drive pressure of 75 psi was applied (full FDB-AC drive pressure). No axial force pressure was applied. The FDB-AC was running at full idle speed. Because the working environment is not known, this method was considered the best method for measurements.

The equivalent continuous A-weighted sound pressure level was measured as 75 dB (A).

The peak C-weighted instantaneous sound pressure value was measured as 87 dB(C).

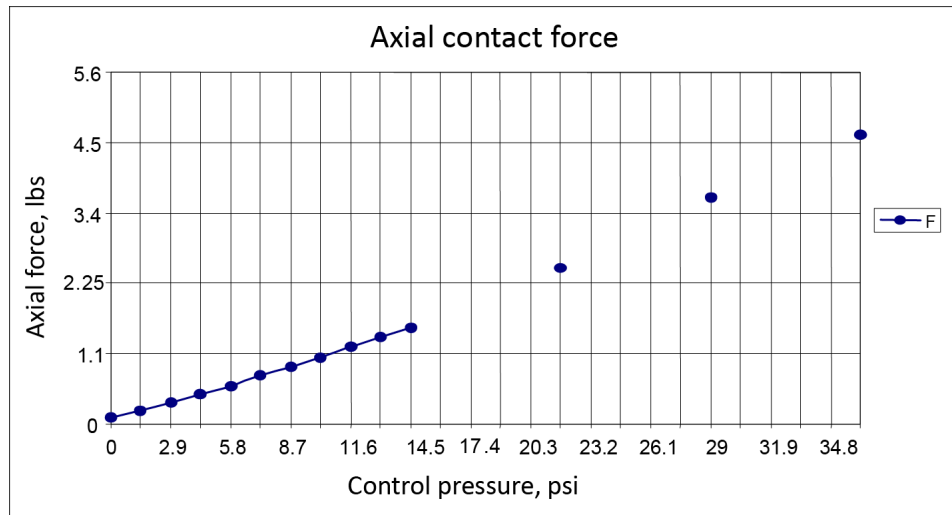

*Axial contact force, measured with rotary burr pointing downwards*

Each FDB-AC goes through a thorough test procedure before it is shipped. In the figure are theoretical and measured forces relative to applied axial air pressure. Please note that theoretical calculations are not necessarily identical to actual data.

Measurements may vary from one product to another, and should only be treated as nominal.

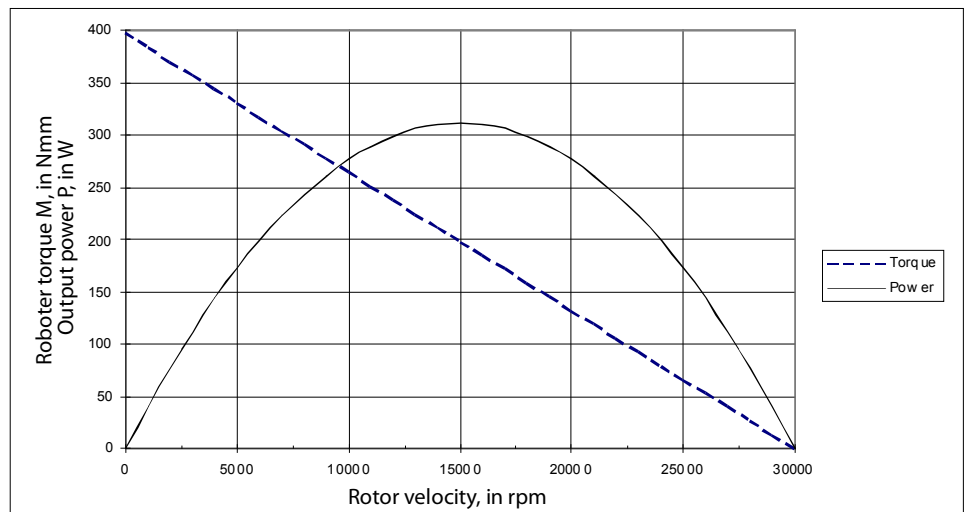

*Theoretical calculations, FDB-AC output torque and power*

Due to pressure losses between the pressure regulator and the compensation piston, the axial force is lower than theoretical calculations will predict. The actual force characteristics will change from installation to installation due to different types of pneumatic components used.

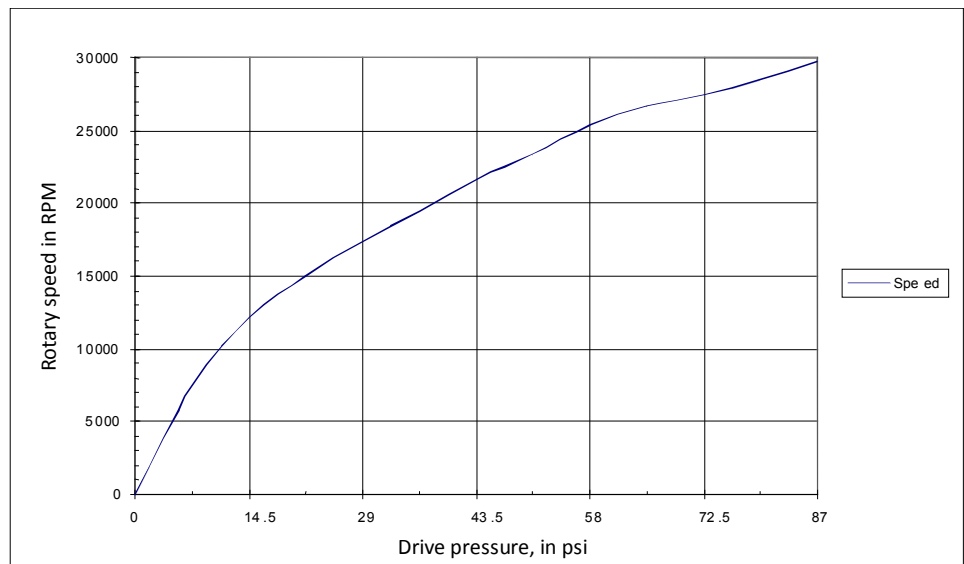

*Idle speed as function of applied drive pressure*

We recommend a working speed of 15,000 to 25,000 RPM for maximum possible output. A speed lower than 15,000 RPM is not recommended, as it increases the risk of stalling the motor, due to the higher torque at lower speeds.

## 5.2 Environmental Limitations

<b>General</b>	Area classification:	None
	Gas group/ignition group:	None

<b>Operation</b>	Installation position:	<ul style="list-style-type: none"> <li>• Mounted to robot by means of the Speedeburr adapter and flange. The flange is specific to each type of robot. This flange not supplied by SCHUNK .</li> <li>• Mounted to a table or stand by means of the Speedeburr adapter (the robot is carrying the workpiece).</li> </ul>
	Temperature range:	5°C–35°C 41°F–95°F

<b>Storage</b>	Temperature range:	0°C–45°C 32°F–113°F
----------------	--------------------	------------------------

**Conditions** The tool should be stored in its crate and in a dry place. The tool should be kept dry and full of pneumatic oil when stored. Keep unit in crate if possible. ([👉 6.4, Page 20](#))

## 6 Handling, Installation, Storage and Transportation

### 6.1 Inspection of Condition when Delivered

Upon receipt, the following must be checked:

- Delivery in accordance with freight documents
- Damage to packaging

If there is damage to any of the packaging, or if any of the goods have been exposed to abnormal handling, unpack those parts that may have been damaged for a closer inspection. If necessary, notify SCHUNK for assistance in evaluation of the product condition.

### 6.2 Unpacking and Handling

The FDB-AC tool, during transportation, storing and handling, should always be placed inside the accompanying box (crate).

### 6.3 Installation

#### 6.3.1 Mounting, Adapter and Interface Plate

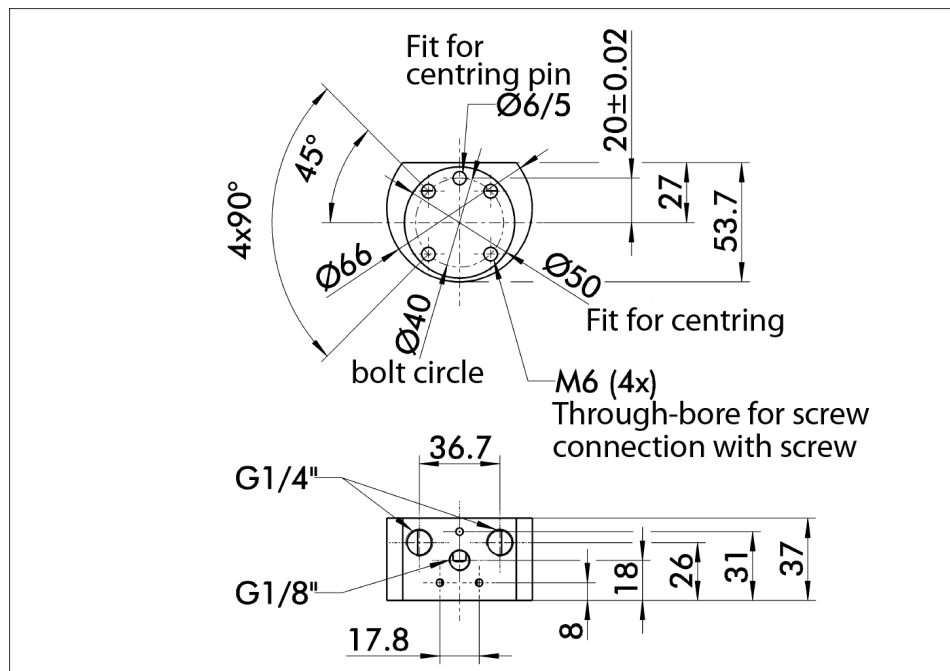

Speedburr (FDB-AC) Adapter

The Figure shows the Speedburr pneumatic adapter (Id.-No. 9951358). This adapter, or equivalent, should be used for mounting the FDB-AC to the robot or to other equipment. The adapter facilitates the connection of the pneumatics to the FDB-AC.

The FDB-AC can be mounted on the robot or on a stand in which case the robot carries the part to be deburred to the FDB-AC. The FDB-AC is mounted to the Speedeburr adapter by means of 8 screws M4. Be sure the O-rings are positioned correctly into the grooves on the FDB-AC bracket before mounting the FDB-AC to the pneumatic adapter. Removable thread locker should be used for all mounting bolts.

The Speedeburr adapter is mounted to the wrist of the robot, usually by means of a robot-specific interface plate. In some cases, the Speedeburr adapter will mount directly to the robot without an interface plate. The interface plate is manufactured either by the robot supplier, the FDB-AC supplier, the system integrator, or by the owner/user of the FDB-AC.

The FDB-AC, with the Speedeburr adapter, may be mounted to a table or stand using an interface plate or directly using the Speedeburr pneumatic adapter.



### 6.3.2 Pneumatics FDB-AC 90

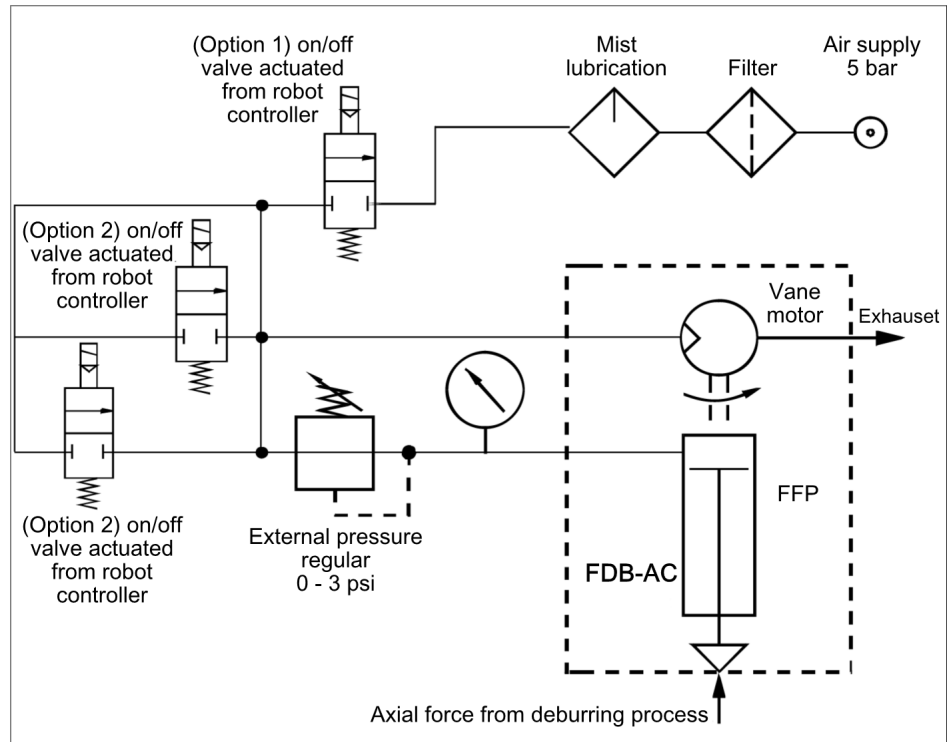

Connect the FDB-AC 90 as shown in the figure.

Two connection methods are shown.

- Option 1 uses one solenoid valve to control both motor drive air supply and axial force air supply.
- Option 2 uses two solenoid valves to independently control the two air supplies.

### 6.3.3 Pneumatics FDB-AC 180

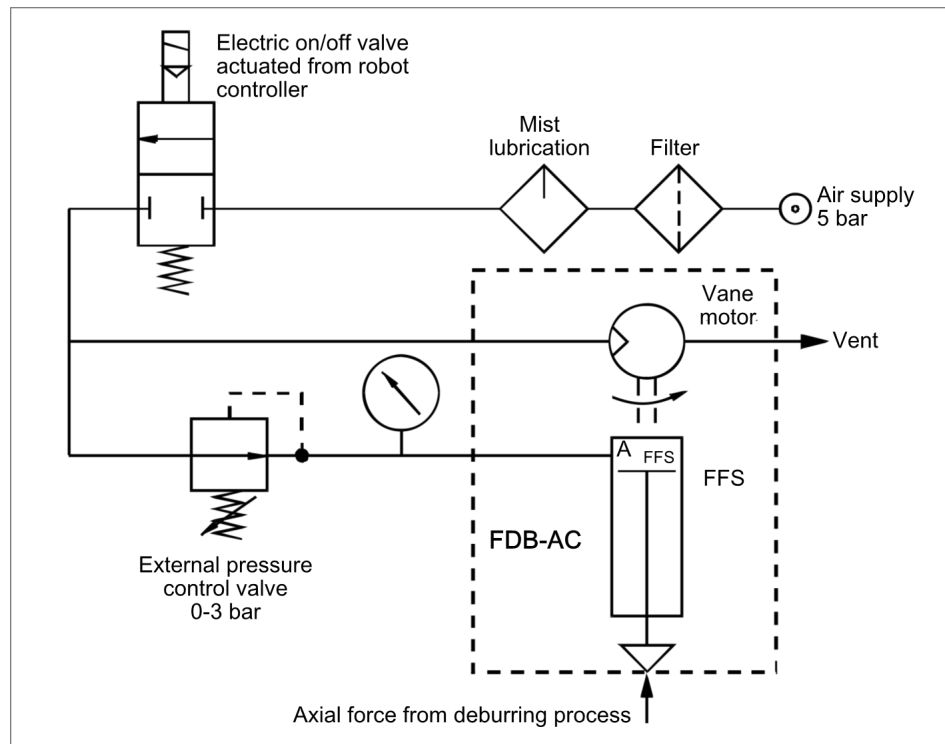

*Pneumatic Connection*

Connect the FDB-AC 180 as shown in the figure.

A special Speedeburr adapter is available as extra equipment, to enable standard air nipples to be coupled to the Straight FDB-AC. Air silencers can be coupled to the exhaust ports of the adapter, to take away the noise when exhaust air enters the atmosphere. The drive air to the vane motor should be mist lubricated by use of conventional pneumatic equipment.

An external pressure control valve, for example mounted on the industrial robot's upper arm, will control the axial force on the rotary tungsten carbide file.

The axial force is adjusted until a chamfer with the correct width is produced, for a given path speed.

#### **NOTE**

Poor performance will result if the correct components are not used. Pneumatic components used for the motor drive circuit must be able to meet the air consumption requirements ([5.1, Page 11](#))

Conventional pneumatic components (not supplied with the FDB-AC tool) are used to control the air supply to the FDB-AC. SCHUNK recommends that the user install a pneumatic pressure regulator in order to achieve a stable air supply and to reduce the air supply to the maximum of 90 psi.

The solenoid-operated valve(s) are actuated from the robot controller by means of a digital output signal.

The external pressure regulator is used to control the air supply to the axial force compliance mechanism, thus enabling control of the axial force on the rotary burr. If the complete workpiece can be deburred with equal axial force, a conventional manual pressure regulator can be used. If the burrs to be removed are varying from place to place on the workpiece, and this variation is repeatable for all workpieces of the same type, it may be necessary to adjust the axial force by using an analog pressure regulator controlled from the robot controller. An analog output port in the robot controller will be needed.

Function	Thread Type	Pressure
Motor inlet	1/8"	3,1 - 5,2 bar maximum 6,2
Axial (contact) force inlet	M5	0 - 3,1 bar, maximum 3,1 bar
Control functions	M5	Optional
Exhaust	1/4"	Not Applicable

It is recommended that 3/8" plastic tube be used for the motor air supply inlet, and 5/32" tube for the axial force air supply inlet. Note that a M5 connection is used for the axial force air supply inlet, and a 1/8" connection for the motor air supply inlet. Use two silencers directly mounted on the two 1/4" exhaust outlets ([↩ 5.1, Page 11](#)).

If more noise suppression is desired, install silencers on the exhaust line further away from the Speedeburr adapter. An oil recovery unit may be installed on the exhaust line to avoid the mist lubrication droplets from entering the atmosphere around the robot installation. Additionally, to reduce the sound in neighboring working areas, a barrier ([↩ 7.2, Page 22](#)) surrounding the installation may be installed (Plexiglas or Lexan is preferred).

The axial force air supply pressure regulator should have a 0–45 psi range. When testing for the proper contact force start with a very low pressure and increase slowly until the desired chamfer is achieved (typically 3 psi for aluminum and more for steel workpieces).

Before start-up make sure the air lubrication system is filled with oil. ([↩ 8.3, Page 31](#))



#### NOTICE

**Lack of lubrication will cause destruction of the motor within a relatively short time.**

If the lubrication is not working properly, you can hear the motor running slower than normal, and the speed may be varying.

- Install the lubrication equipment near the robot base (maximum 16 feet away from the FDB-AC) for proper operation.

[\(👉 8.3, Page 31\)](#)

### 6.4 Transportation and Protection during Transportation

The FDB-AC is packaged in a wooden crate designed to secure and protect it during transportation. Always use the crate when transporting the FDB-AC in order to minimize the risk of damage.

When taking the FDB-AC out of the crate and carrying, or performing maintenance, try to always grab and hold it around the motor housing Drawings.

### 6.5 Storage and Preventive Maintenance during Storage

The FDB-AC should be stored in the wooden crate when it is not in use. The FDB-AC should also be stored in a dry place.

For short-term storage (limited to a few weeks), no preventive maintenance is needed, except for cleaning.

For long-term storage, the FDB-AC should be thoroughly cleaned of any burrs or debris. It should not be disassembled. After cleaning, the FDB-AC should be "filled" with oil of the same type used as lubrication during operation. The oil should be poured into the FDB-AC through the adapter or through the FDB-AC bracket. Place the FDB-AC inside a sealed plastic bag and place the FDB-AC inside the crate. This is necessary in order to keep the blades in the air-vane motor from drying out and for preventing the risk of corrosion.

## 7 Operating Instructions

These operating instructions are intended to help system integrators program, start up and complete a robotic deburring cell containing a FDB-AC deburring tool. The system integrator should be familiar with the task of deburring in general and should have extensive knowledge relating to robots and automation incorporating robots.

The system integrator is responsible for providing user documentation for the complete deburring installation. This document is not intended to cover all aspects of such an installation, although it contains some information vital for the system user, such as maintenance instructions for the FDB-AC and instructions related to safety.

### 7.1 General Precautions

	<b>! WARNING</b>
	<p><b>Neglecting safety precautions can create hazardous situations,</b> In the worst case, personnel can be injured or the deburring installation and the FDB-AC can be damaged.</p> <ul style="list-style-type: none"> <li>• It is important that all personnel involved in operation of the FDB-AC have a thorough understanding of the operating procedures.</li> <li>• The FDB-AC must only be used for robotic deburring applications. The FDB-AC is a deburring tool only.</li> <li>• Never use the FDB-AC for purposes other than robotic deburring.</li> </ul>

Grinding, countersinking or other metal-forming processes should not be performed by the FDB-AC. It may be dangerous to operate the FDB-AC for these purposes. If a failure occurs due to forces caused by improper use, hazardous situations for both personnel and equipment could be created. The FDB-AC is intended to perform deburring only.

The FDB-AC should not be used to deburr materials that are prone to fracture. A fracturing workpiece may result in pieces of material damaging surrounding working environment and personnel. Material removed correctly should be in the form of chips.

Reduce the robot velocity when the workpiece and the FDB-AC are making initial contact. Making the contact movement between the FDB-AC and the workpiece too fast may in some situations result

in a collision. Collisions may create hazardous situations for both personnel and equipment.

When performing maintenance, always remember to tighten nuts and bolts thoroughly and **use a removable thread lock adhesive**. When replacing burrs, always attach the burr correctly. ([👉 8.4, Page 32](#))

	<b>! WARNING</b>
	<b>Never use the FDB-AC as a hand-held machine.</b>

In order to increase the life of the FDB-AC motor and bearings, always use proper lubrication. ([👉 8.3, Page 31](#))

## 7.2 FDB-AC Working Environment

As described in previous sections, the FDB-AC should only be used in conjunction with a robot in a secured work cell/chamber.

The work cell must be secured by means of barriers to prohibit personnel from entering the cell. A lockable door should be included as a part of the barrier in order to facilitate access to the cell for authorized personnel only. The barrier could consist partly or fully of Plexiglas to facilitate observation of the deburring operations.

During system or FDB-AC maintenance, make sure the FDB-AC and robot are stopped before entering the robot cell. When installing and testing, never be present in the cell when the FDB- AC is running.

Be aware of rotating parts. Use eye-protection while working around the FDB-AC.

Be aware of high sound levels. Always use hearing protection while working in the neighborhood of the deburring cell.

### 7.3 Tool Center Point (TCP) Position

#### 7.3.1 TCP FDB-AC 90

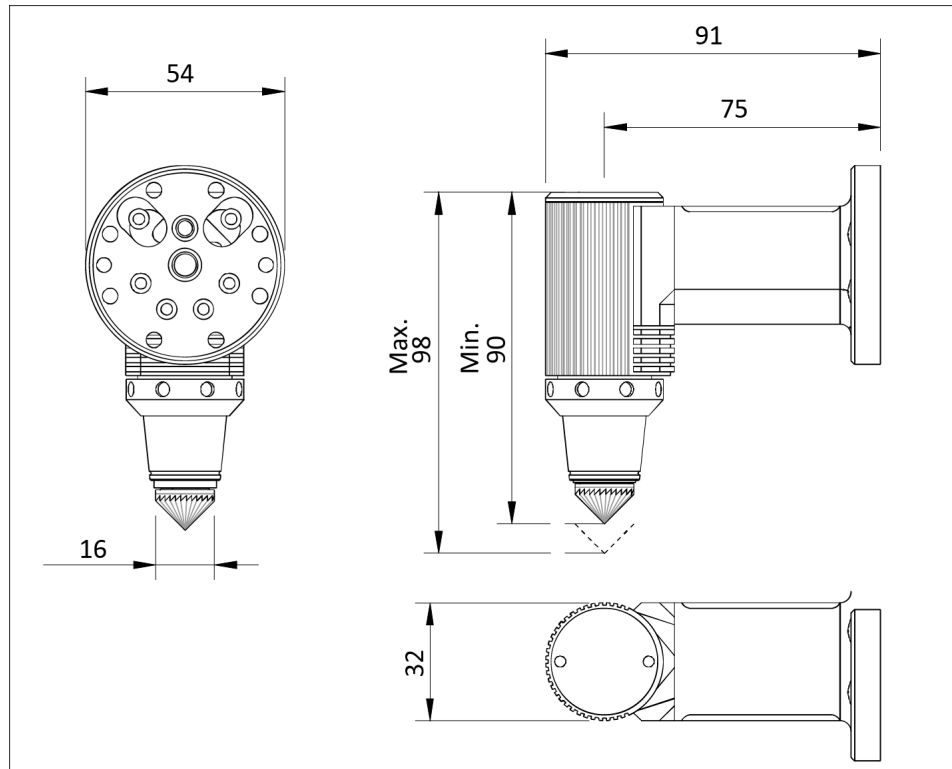

FDB-AC Tool Center Point (TCP) Dimensions

The Figure shows the TCP position and FDB-AC dimensions. When setting the TCP position in the robot controller, use the mid- position of the 0.31-inch axial stroke of the compensation piston. Also remember to take into account the depth of the Speedeburr adapter ([6.3.1, Page 15](#)). In case an additional interface plate is used in order to fit the adapter to the robot, this depth must be considered as well.

Without Speedeburr adapter:	Dx = 75 mm	Dy = 0 mm	Dz = -70 mm
With Speedeburr adapter:	Dx = 110 mm	Dy = 0 mm	Dz = -70 mm

### 7.3.2 TCP FDB-AC 180

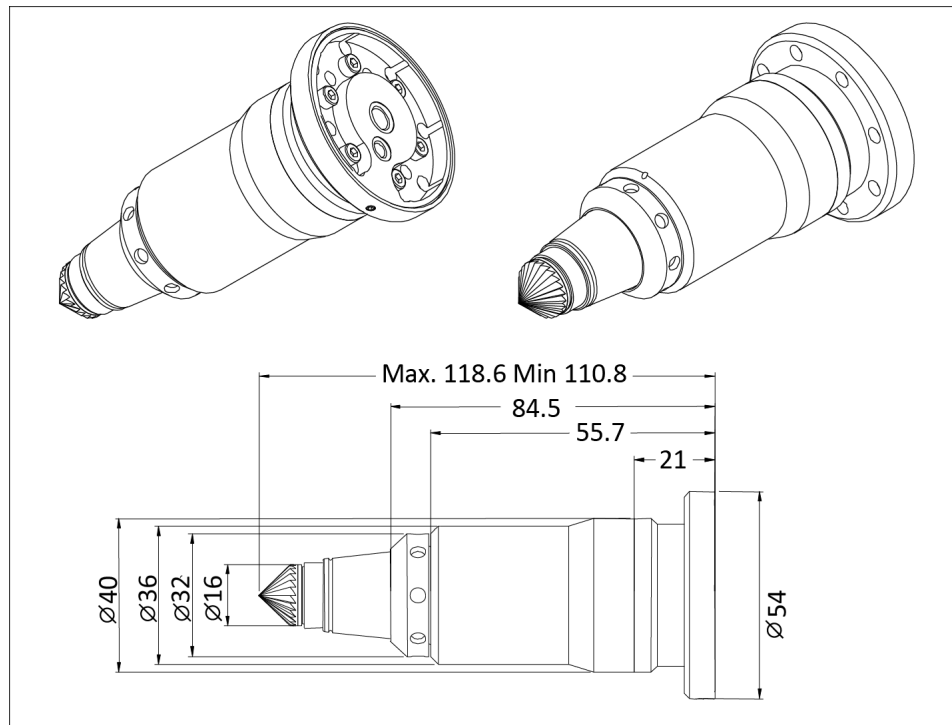

FDB-AC Tool Center Point (TCP) Dimensions

The Figure shows the TCP position and FDB-AC dimensions. When setting the TCP position in the robot controller, use the mid-position of the 0.31-inch axial stroke of the compensation piston. Also remember to take into account the depth of the Speedburr adapter ([6.3.1, Page 15](#)). In case an additional interface plate is used in order to fit the adapter to the robot, this depth must be considered as well.

Without Speedburr adapter:	Dz = -115 mm
With Speedburr adapter:	Dz = -150 mm



## 7.4 Operational Considerations

To obtain best results, it is important for the Compensation piston to be running with low friction in the cylinder. ([👉 7.1, Page 21](#))

The FDB-AC should not be statically mounted with the cutting tip up. This will increase the amount of debris entering the cylinder and cause premature wear of the cylinder and piston, possibly preventing the piston from floating altogether. If the FDB-AC must be mounted in this orientation then a continuous or regular burst of high velocity air should be used to blow debris away from the piston and cylinder to insure low friction between the Compensation piston and the cylinder.

For instructions on how to replace the burr, please consult section "Replacement of Burrs" ([👉 8.4, Page 32](#))



### NOTICE

**The FDB-AC should not be statically mounted with the cutting tip up.**

**This will increase the amount of debris entering the cylinder and cause premature wear of the cylinder and piston, possibly preventing the piston from floating altogether.**

Under normal conditions, no cooling or lubrication of the rotary burr is necessary. The FDB-AC is used in most robot deburring installations with aluminum and steel workpieces without any coolants.

## 7.5 Programming

The FDB-AC must never be running while programming the robot. There are various techniques that may be used to program the robot path. In any case, the burr should be nominally at the mid-point of its stroke while deburring the part. It will move up and down with part and path variation.

One programming method is to teach the path using the point of the burr as a guide, following the edge of the part, then manually or automatically adding offsets to the path points to achieve the final correct burr path. Another method is to program the actual points making sure that at each point the burr is at its nominal mid-point when in contact with the part, and that there are no radial forces. The method used will depend on the robot's capabilities and programmer preferences.

If you are deburring sharp inner corners, it may be required to use the area of the burr closer to its tip. Note that, in this case, some of the compensation ability of the FDB-AC as well as the cutting surface speed is reduced. When running the robot program the first time, observe the path with the axial supply turned off. When increasing the path speed it is important to notice that path deviation may increase with speed. Verify that at operational robot path speed the FDB-AC burr remains near the mid-point of its axial travel.



### NOTICE

**The brass Cylinder (5) ([8.1.1, Page 28](#)) ([8.1.2, Page 29](#)) that encloses the Compensation piston must be protected from collisions. If struck it may be damaged and need replacement**

The axial force of the burr should be adjusted in order to achieve a correct sized and even chamfer. ([6.3.3, Page 18](#))

### Addition FDB-AC 90:

To change the drive speed, adjust the main supply pressure. The greater the pressure, the greater the speed and vice versa. It is also possible to adjust the speed by using a small flat-blade screwdriver to turn the adjustment screw on the side of the 90-degree bracket ([8.1.1, Page 28](#)) and ([9.1, Page 34](#)). This adjustment varies the flow rate, clockwise to decrease, counterclockwise to increase the flow rate (and speed). In most applications, it is best to adjust the regulator to a maximum pressure (75–90 psi) with the adjustment screw in the full out position, approximately flush with the surface



### NOTICE

**The FDB-AC must never run without proper lubrication. Damage to the unit will occur. ([8.3, Page 31](#))**

## 8 Maintenance

### 8.1 Regular Operational Maintenance

To obtain best results, it is important for the piston to be running with low friction in the cylinder.

This should be checked at regular intervals. Some debris will always enter the cylinder and regular cleaning is recommended.

The FDB-AC should not be operated for extensive periods of time with the cutting tip pointing up. This orientation will increase the amount of debris entering the cylinder and cause premature wear of the cylinder and piston, possibly preventing the piston from floating altogether. If the FDB-AC must be operated in this orientation then a continuous or regular burst of high velocity air should be used to blow debris away from the piston and cylinder to insure low friction between the Compensation piston and the cylinder.

Additionally, the outside of the FDB-AC should be kept clean to ensure proper cooling.

### 8.1.1 User Serviceable parts FDB-AC 90

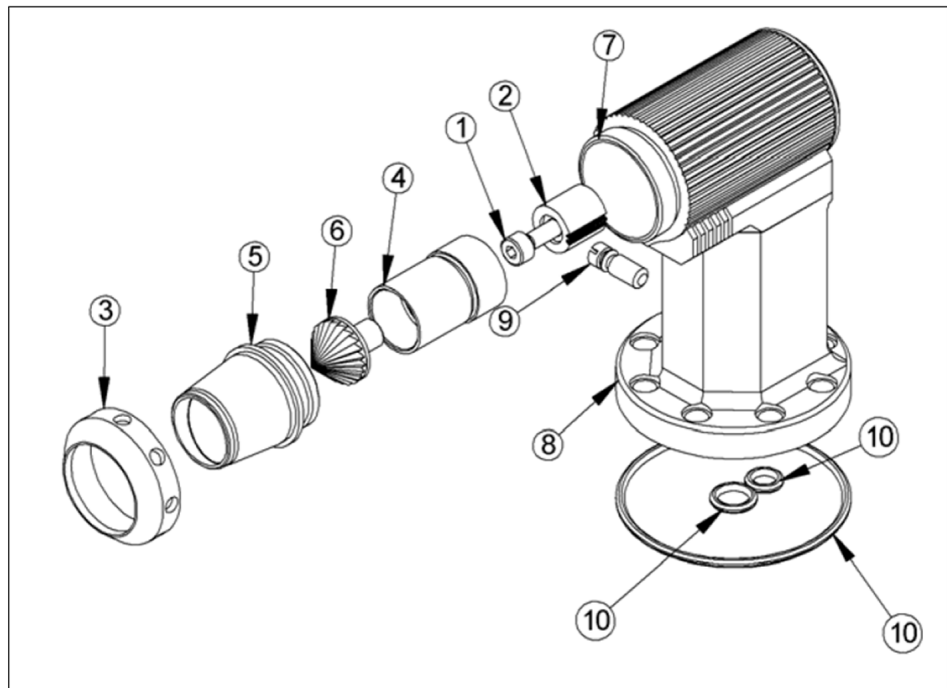

User-Serviceable Parts

Item	Quantity	Description
1	1	Spine Lock Screw
2	1	Male Spline
3	1	Lock Ring
4	1	Compensation piston
5	1	Cylinder
6	1	Rotary File (Burr)
7	1	Motor Housing
8	1	90 Degree Bracket
9	1	Adjustment Screw
10	1	O-ring Set

### 8.1.2 User Serviceable parts FDB-AC 180

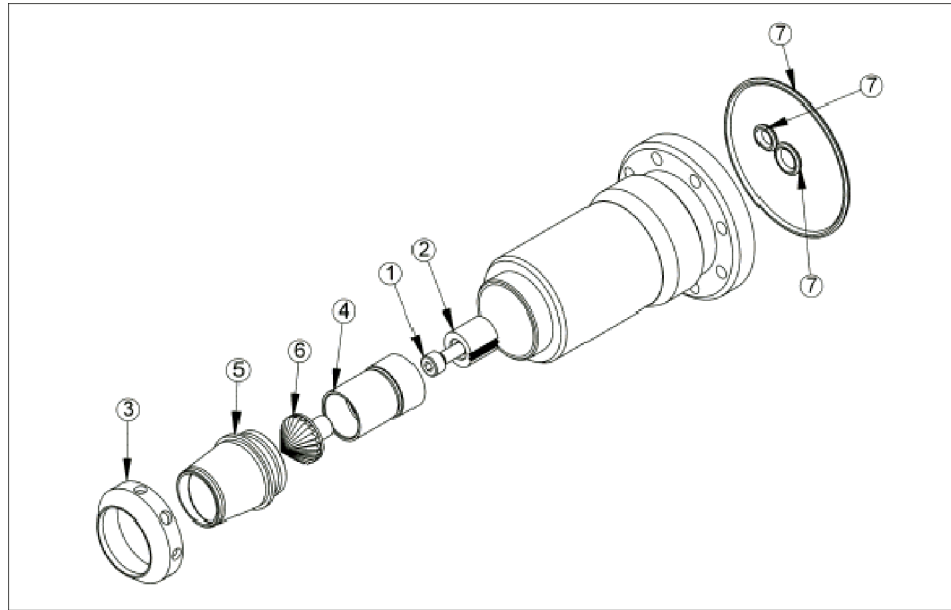

User-Serviceable Parts

Item	Quantity	Description
1	1	Spine Lock Screw
2	1	Male Spline
3	1	Lock Ring
4	1	Compensation piston
5	1	Cylinder
6	1	Rotary File (Burr)
7	1	O-ring Set

## 8.2 Recommended Inspection and Cleaning Procedure

Position of the position numbers([☞ 8.1.1, Page 28](#))([☞ 8.1.2, Page 29](#))

- 1 Remove the Lock Ring (3) from the FDB-AC Motor Housing (7) using the hook spanner wrench (not shown).
- 2 Gently pull the Cylinder (5) and Compensation piston (4) assembly from the FDB-AC Motor Housing.
- 3 Thoroughly clean the Male Spline, the interior of the Motor Housing, and the Lock Ring with a mild solvent.
- 4 Spin the burr by holding the Compensation piston and assure it spins freely. If it does not spin freely, replace the Compensation piston.
- 5 Separate the Compensation piston from the Cylinder and clean thoroughly.

- 6 Inspect the Compensation piston and Cylinder for scratches. Deep scratches may require replacement of the part(s).
- 7 Check the Burr (I6) condition and replace as necessary.
- 8 Lightly lubricate the outside diameter of the Compensation piston and the inside diameter of the Cylinder with the same oil used for operational air lubrication.
- 9 Assemble the Compensation piston in the Cylinder and assure the Piston moves freely without excessive play. The fit between the Compensation piston and the Cylinder provides the seal for the axial down force air pressure, therefore the fit must be consistent and without excessive play. If the play is excessive, replace the Cylinder.
- 10 Install the Cylinder and the Compensation piston assembly on the Motor Housing.
- 11 Replace the Lock Ring. **NOTICE! Do not over tighten the Lock Ring.**
- 12 Assure the axial down force and the drive are working properly



**NOTICE**

**The FDB-AC should not be operated for extensive periods of time with the cutting tip pointing up. This orientation will increase the amount of debris entering the cylinder and cause premature wear of the cylinder and piston, possibly preventing the piston from floating altogether.**

The burr must be replaced at regular intervals. During initial production, the burr and the workpiece should be examined often in order to determine at what interval the burr should be replaced ([👉 8.4, Page 32](#)).

At regular intervals (normally once every two years, or more often depending on the application), an overhaul of the FDB-AC should be performed in order to fully comply with the technical specifications. Parts inside the FDB-AC, such as the blades in the air-vane motor and bearings should be replaced as part of the overhaul ([👉 8.6, Page 33](#)).

At regular intervals, the pneumatics used to control the FDB-AC should also be checked, especially the air-filter and lubricator. Remember to fill the lubricator with oil.

### 8.3 Lubrication

Before start-up, be sure a lubricator is installed as described in the pneumatic diagram Drawings

Make sure the air lubrication system is filled with oil.

Use oil similar to machine oil #10, spindle oil #60, Shell/Exxon ATF DEXRON II automatic transmission oil, or similar.

**Oilfog** air lubrication systems **are not** recommended as a means for providing lubricated air for this product. Only **microfog** systems should be used. The system should be adjusted to 10–15 drops per minute. Only part of the oil drop actually enters the air stream. Fill the lubricator with the proper type of oil at regular intervals.



#### NOTICE

- When the system is first installed, use a higher than recommended oil setting (approx. 2 times) until the unit is receiving consistently oiled air.
- Run oil through the entire pneumatic tube between the oiler and the unit prior to operation.



#### WARNING

##### **Damage to health due to inhalation of air containing oil!**

Long-time exposure to air containing oil could be dangerous for personnel.

- It is recommended that the exhaust containing lubrication be filtered through an oil-recovery system before exhausting it to the atmosphere.



#### NOTICE

**Lack of lubrication will cause untimely wear on the motor and failure within a relatively short period. If the lubrication is not working properly, the motor will run slower than normal, and may vary in speed. Install the lubrication equipment near the robot base (maximum 16 feet from the FDB-AC) for best results.**

## 8.4 Replacement of Burrs

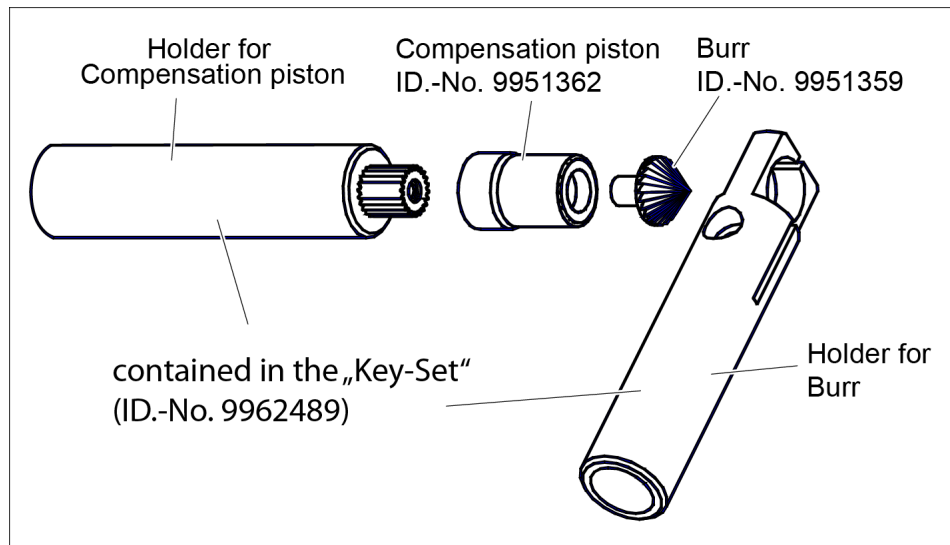

*Burr Replacement*

The Figure shows the burr-changing tools, the Compensation piston and burr (rotary file). The Compensation piston and the Cylinder should be inspected whenever a burr is replaced. The Compensation piston should rotate freely (by hand) in the Cylinder with no binding. If binding is detected, the Compensation piston and/or Cylinder should be replaced ([↗ 8.1, Page 27](#)).

To change the burr, unscrew it with the burr-changing tools and replace it with a new one. Re-assemble the parts ([↗ 8.1, Page 27](#)).

After the burr is changed and the unit re-assembled, check that the Compensation piston is rotating with the burr. If the Compensation piston is not rotating, static friction may be interfering so that the axial force cannot remain constant. In that case, clean the Compensation piston and inspect for any visible scratches. If a burr with an imbalance is used, the Compensation piston may also stop rotating. All burrs are checked for imbalance before they are shipped.

Only original SCHUNK burrs should be used.



## 8.5 Replacement of Other FDB-AC Parts

In addition to burrs, FDB-AC parts such as the blades in the air-vane motor and bearings should be replaced at regular intervals (nominally every 2 years) as part of a general overhaul ([↗ 8.6, Page 33](#)).

Experience has shown that during installation, programming, and sometimes during operation, the FDB-AC and the workpiece collide, or the radial forces acting are too high. This sometimes results in damage to the Cylinder and/or the Compensation piston. In this case these parts may also need to be replaced ([↗ 8.1, Page 27](#)).

Only original spare parts supplied by SCHUNK should be used.

## 8.6 Overhaul

As described in previous sections of this User Manual, the motor unit and Compensation piston should be inspected and overhauled at regular intervals. In addition to the above, the FDB-AC should be thoroughly cleaned, inspected and tested. This overhaul must be performed by SCHUNK in order to maintain the technical specifications and tool life of the FDB-AC.

## 8.7 Repairs and Spare Parts

For repair and spare parts please contact SCHUNK.

User- serviceable parts are shown in Figure "Burr -Replacement" ([↗ 8.4, Page 32](#)). For the replacement of the burr, a "Keyset" (ID number 9962489) is available.

All other repairs must be performed by SCHUNK.

SCHUNK recommends stocking the following spare parts in addition to burrs:

- Compensation piston - ID number 9951362
- Cylinder - ID number 9951361

Use only original spare parts and burrs from SCHUNK.

## 9 Drawings

### 9.1 FDB-AC 90

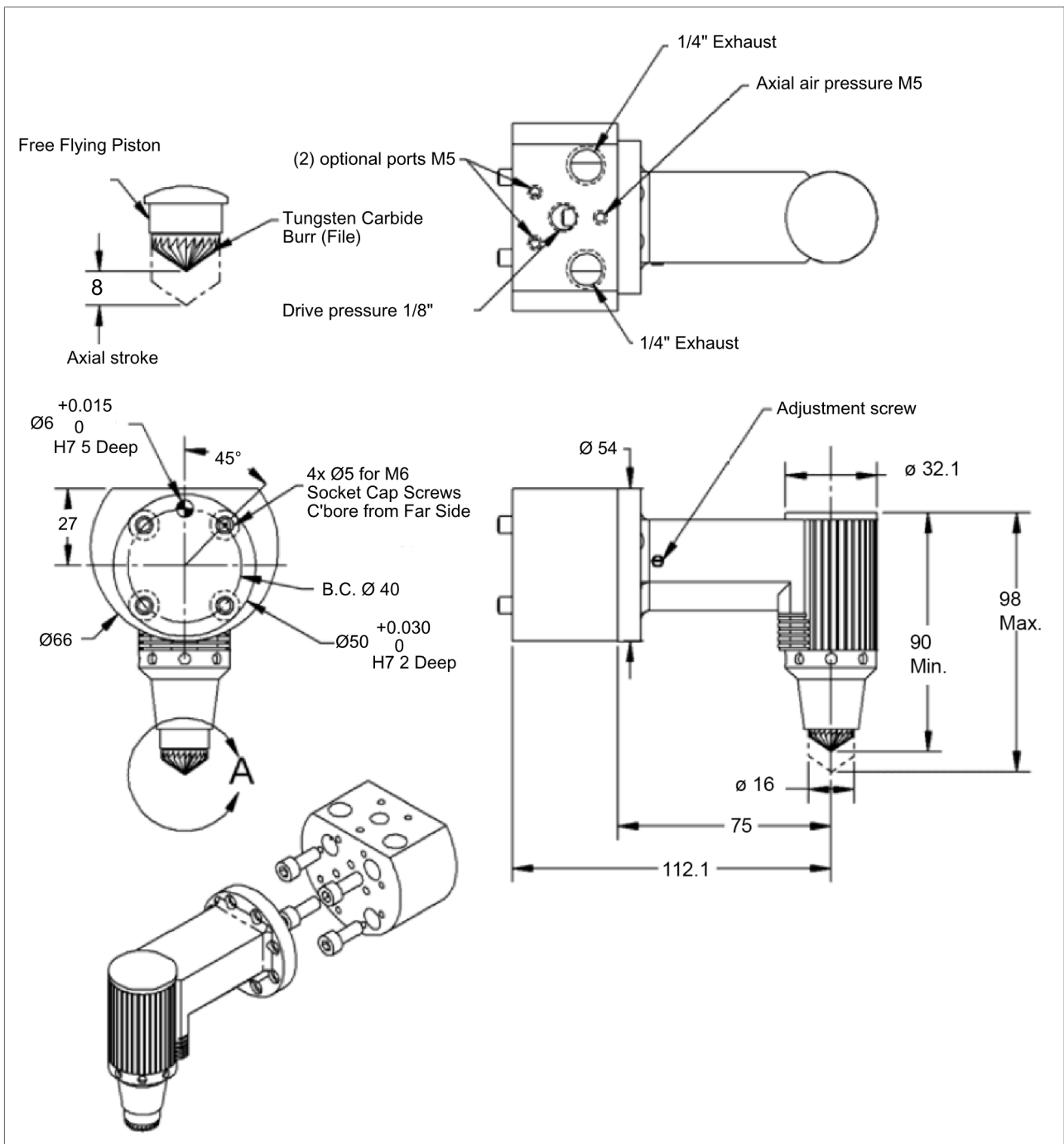

## 9.2 FDB-AC 180

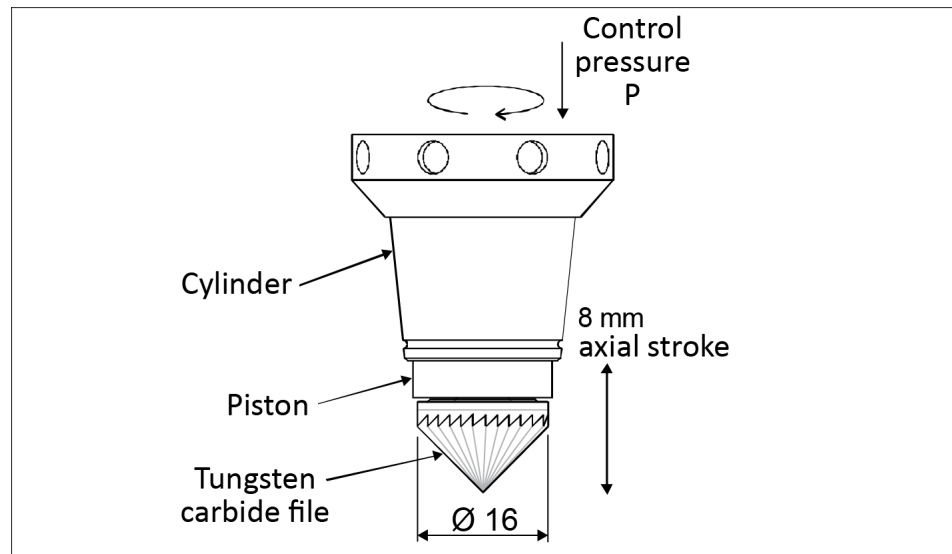

The Compensation piston is an important part of the Straight FDB-AC. The Compensation piston is pushed forward into contact with the burr edge by use of a remotely controlled air pressure.

The air vane motor is decoupled from the linear movement of the Compensation piston, to reduce inertia and increase the stability of the contact force when deburring. The spline coupling transmits torque to the rotary file.

Ball bearings ensure an even running of the tungsten carbide file. A very little friction torque is transmitted through the ball bearings to the Compensation piston cylinder, which rotates slowly inside the stationary outer cylinder. Thus stick-slip or static friction of the Compensation piston is avoided. The Compensation piston cylinder is in addition precision ground to ensure very little friction in the axial direction.

## 10 Translation of original declaration of incorporation

in terms of the Directive 2006/42/EG, Annex II, Part 1.B of the European Parliament and of the Council on machinery.

Manufacturer/ SCHUNK GmbH & Co. KG Spann- und Greiftechnik  
Distributor Bahnhofstr. 106 – 134  
D-74348 Lauffen/Neckar

We hereby declare that on the date of the declaration the following incomplete machine complied with all basic safety and health regulations found in the directive 2006/42/EC of the European Parliament and of the Council on machinery. The declaration is rendered invalid if modifications are made to the product.

Product designation: Robotic Deburring Tool / FDB-AC 90 - 180 /  
ID number 0322206, 0322207

The incomplete machine may not be put into operation until conformity of the machine into which the incomplete machine is to be installed with the provisions of the Machinery Directive (2006/42/EC) is confirmed.

The manufacturer agrees to forward on demand the relevant technical documentation for the partly completed machinery to state offices.

The special technical documents according to Appendix VII, Part B belonging to the incomplete machine have been compiled.

Person authorized to compile the technical documentation:  
Robert Leuthner, Address: see manufacturer's address

*Signature – see original declaration*

Lauffen/Neckar, June 2014

p.p. Ralf Winkler,  
Head of Gripping Systems Development