

FFD 3.5" Ultra320 SCSI
Product Specification and User Manual

November 2005
43-PS-0305-00 Rev. 2.0

DOCUMENT CONTROL INFORMATION

DCO No.:

| | Title | Name | Date |
|---------------------|---|--------------|----------------|
| Issued by: | Rugged Product Manager, Embedded Division | Guy Freikorn | April 20, 2005 |
| Approved by: | VP Marketing, Embedded Division | Ofer Tsur | April 20, 2005 |

REVISION HISTORY

| Revision | Date | Description | Reference |
|-----------------|---------------|--|---|
| 2.0 | November 2005 | Added information for new form factor, FFD 3.5" Ultra320 SCSI 68-pin | Sections 4.1.7, 4.1.8, 4.1.10, 4.2, 4.4.4, 4.4.5, 8.1.12, 8.3, 11.5, 14, 16, 17 |

TABLE OF CONTENTS

| | |
|---|-----------|
| 1. Scope | 6 |
| 2. Applicable Documents | 6 |
| 3. Overview | 7 |
| 4. Specifications..... | 8 |
| 4.1. Characteristics..... | 8 |
| 4.1.1. Supported SCSI Modes | 8 |
| 4.1.2. Bus Characteristics | 8 |
| 4.1.3. Performance | 8 |
| 4.1.4. Access Time | 9 |
| 4.1.5. Start-Up Time..... | 9 |
| 4.1.6. Seek Time..... | 9 |
| 4.1.7. Power Requirements and Consumption..... | 10 |
| 4.1.8. Memory Capacities | 10 |
| 4.1.9. Endurance..... | 12 |
| 4.1.10. Physical Characteristics..... | 12 |
| 4.1.11. Hot Insertion (Hot Swappable)..... | 19 |
| 4.2. Reliability | 20 |
| 4.3. Embedded Error Detection and Error Correction Code (EDC/ECC) | 20 |
| 4.4. Environmental Conditions | 20 |
| 4.4.1. Temperature | 20 |
| 4.4.2. Altitude | 21 |
| 4.4.3. Relative Humidity | 21 |
| 4.4.4. Shock | 21 |
| 4.4.5. Vibration..... | 21 |
| 4.5. Compliance with Standards..... | 21 |
| 4.6. Access/Activity LED | 21 |
| 5. Supported SCSI Commands | 22 |
| 6. SCSI Messages..... | 24 |
| 7. Packetized SCSI | 25 |
| 8. Vendor-Specific Commands | 26 |
| 8.1. Security Erase Features..... | 26 |
| 8.1.1. Full Security Erase Option..... | 26 |
| 8.1.2. Partial Security Erase Option..... | 26 |
| 8.1.3. Resume Option | 27 |
| 8.1.4. Fill-Format Option | 27 |

| | | |
|------------|---|-----------|
| 8.1.5. | Configuration..... | 27 |
| 8.1.6. | Verifying Security Erase | 35 |
| 8.1.7. | Sanitizing Based on DoD 5220.22-M | 36 |
| 8.1.8. | Sanitizing Based on NSA Manual 130-2 | 36 |
| 8.1.9. | Sanitizing Based on USA Air Force AFSSI 5020 | 37 |
| 8.1.10. | Sanitizing (Purging) Based on USA Army Regulation 380-19..... | 37 |
| 8.1.11. | Sanitizing (Purging) Based on USA Navy NAVSO P-5239-26..... | 38 |
| 8.1.12. | Declassification Based on IRIG-106 (NTISSP-9) | 38 |
| 8.2. | Security Erase Functionality..... | 41 |
| 8.3. | Power Consumption during Security Erase..... | 42 |
| 8.4. | LED Indicator During Erase..... | 42 |
| 9. | Firmware Upgrade..... | 43 |
| 10. | Sense Key and Additional Sense Key Codes..... | 44 |
| 11. | Configuring and Installing the FFD 3.5" Ultra320 SCSI..... | 46 |
| 11.1. | Package Contents..... | 46 |
| 11.2. | Visual Inspection | 46 |
| 11.3. | Handling Instructions..... | 46 |
| 11.4. | System Requirements | 47 |
| 11.5. | Configuring the FFD 3.5" Ultra320 SCSI..... | 47 |
| 11.5.1. | SCSI ID Pins | 48 |
| 11.5.2. | Termination Pins..... | 49 |
| 11.5.3. | Forced Single-Ended Electrical Interface Pins | 49 |
| 11.5.4. | Write Protect Pins | 49 |
| 11.5.5. | Secure Erase Pins | 49 |
| 11.5.6. | Termination Power (TRMPWR)..... | 50 |
| 11.5.7. | LED Pins..... | 50 |
| 11.5.8. | 80-Pin Connector..... | 50 |
| 11.5.9. | 68-Pin Connector..... | 50 |
| 11.6. | Installing the FFD 3.5" Ultra320 SCSI | 52 |
| 11.6.1. | Installing the FFD in a PC..... | 52 |
| 11.6.2. | Using the FFD in MS-DOS-Based Platforms..... | 54 |
| 11.6.3. | Using the FFD in Microsoft Windows-Based Platforms..... | 55 |
| 11.6.4. | Using the FFD in Linux-Based Platforms | 55 |
| 11.6.5. | Using the FFD in Unix-Based Platforms..... | 55 |
| 12. | Troubleshooting..... | 57 |
| 12.1. | Installing Your SCSI Host Adapter | 57 |
| 12.2. | Termination Configuration | 58 |

| | |
|--|-----------|
| 12.3. SCSI ID Configuration | 58 |
| 12.4. Solving Installation Problems | 58 |
| 13. Frequently Asked Questions (FAQs) about the FFD 3.5" Ultra320 SCSI..... | 60 |
| 14. Label Information | 64 |
| 15. Built-In Test (BIT) | 66 |
| 16. Factory Default Setup | 67 |
| 17. Ordering Information | 68 |
| A. Old-Structure Vendor-Specific Security Erase SCSI Command..... | 69 |
| How to Contact Us | 70 |

1. SCOPE

This specification and user manual defines the performance, design and acceptance requirements of the FFD 3.5" Ultra320 SCSI flash disk. It also provides instructions for installing and configuring the FFD 3.5" Ultra320 SCSI flash disk.

Throughout this manual, the FFD 3.5" Ultra320 SCSI flash disk will be referred to as FFD.

2. APPLICABLE DOCUMENTS

- ANSI X3.131-1994 American National Standard for Information Systems - Small Computer System Interface-2 (SCSI-2).
- ANSI X3T9.2/85-82 American National Standard for Information Systems - Common Command Set (CCS) of the Small Computer System Interface (SCSI).
- ANSI INCITS 362-2002, - SCSI Parallel Interface-4 (SPI-4).
- ANSI X3.301-1997 American National Standard Institute Information Technology - SCSI-3 Primary Commands (SPC)
- ANSI NCITS 306-1998 American National Standard Institute Information Technology - SCSI-3 Block Commands (SBC)
- In addition, the ANSI X3.270-1996 and ANSI NCITS 336-2000 documents are applicable.

3. OVERVIEW

The FFD is a non-volatile mass memory storage unit equipped with a SCSI interface, and containing the following subassemblies:

- CPU
- SCSI interface controller
- Flash memory array

The FFD dimensions enabling mounting in a standard 3.5" disk drive enclosure. Figure 1 illustrates the FFD block diagram.

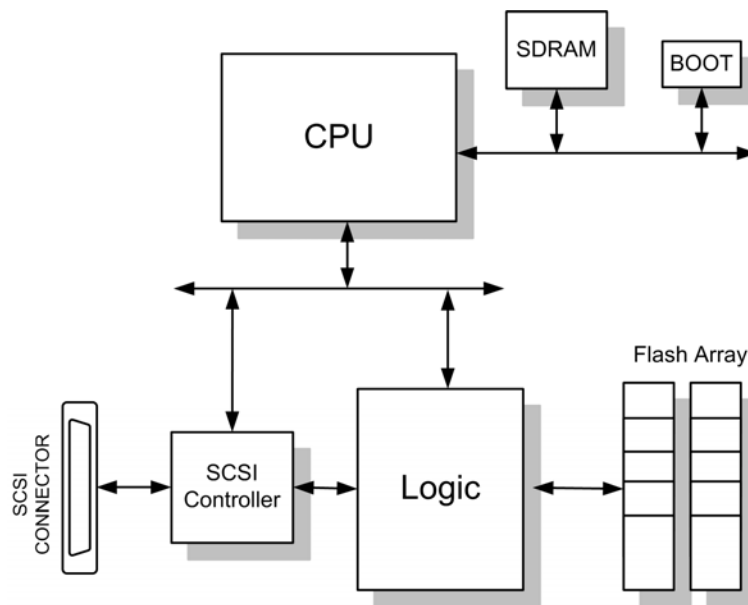

Figure 1: FFD 3.5" Ultra320 SCSI Block Diagram

The FFD interface complies with the SCSI-2 and SCSI-3, and supports the Common Command Set (CCS). Refer to Section 5, Table 13 for a list of supported SCSI commands.

The FFD supports both Single-Ended (SE) and Low Voltage Differential (LVD) electrical interfaces, with 80-pin connector. Refer to Section 4.1.10.3 for specific connector interface details.

4. SPECIFICATIONS

4.1. Characteristics

4.1.1. Supported SCSI Modes

The FFD supports the following SCSI modes:

- Asynchronous mode
- DT/PT modes
 - Wide PT Fast-160 (Ultra320 – 320 MB/sec)
 - Wide DT Fast-80 (Ultra160 – 160 MB/sec)
 - Wide DT Fast-40 (80 MB/sec)
 - Wide DT Fast-20 (40 MB/sec)
 - Wide DT Fast-10 (20 MB/sec)
- ST modes
 - Fast-40 (80 MB/sec)
 - Fast-20 (40 MB/sec)
 - Fast-10 (20 MB/sec)
 - Fast-5 (10 MB/sec)

4.1.2. Bus Characteristics

The FFD has 16-bit bus type (wide), LVD and SE modes.

4.1.3. Performance

Performance testing was carried out using the following setup:

- Bus type: 16-bit (wide)
- SCSI transfer mode: Ultra320 (320 MB/sec)
- OS: DOS and Windows XP
- Transfer size > 1MB
- Benchmark utility: IOMeter (release 12/2003)

The FFD meets the performance requirements, as specified in Table 1.

Table 1: FFD 3.5" Ultra320 SCSI Transfer Rates and IOPS

| Operation | Burst Rate (MB/Sec) | Sustained ⁽¹⁾ Rate 1MB Blocks (MB/sec) | IOPS |
|-----------|---------------------|--|------|
| Read | 320.0 | 40.0 ⁽²⁾ | 1080 |
| Write | 320.0 | 40.0 ⁽²⁾ | 3500 |

- Notes: 1. Transfer of aligned sequential blocks between the target and the initiator.
 2. Sustained read/write rates depend on the measurement utility and the block size.

4.1.4. Access Time

Maximum access time is < 0.02 msec (20 µsec).

4.1.5. Start-Up Time

The required period for the FFD to mount the media and respond to media-related commands (read, write, verify) depends on the media capacity (Table 2).

Table 2: FFD 3.5" Ultra320 SCSI Mount Times

| Capacity (GB) | Time to Mount Media (Seconds, after Low-Level Format) |
|---------------|---|
| 2 | 0.2 |
| 16 | 1.0 |
| 64 | 4.1 |
| 112 | 7.3 |
| 160 | 10.4 |
| 176 | 11.6 |

During the start-up process, all SCSI commands involving media access return the following status conditions:

- CHECK CONDITION, Sense Key NOT READY
and
- Extended Sense Key LOGICAL UNIT IN PROCESS OF BECOMING READY.

FFD supports the Start Stop Unit command, which is commonly used by the host to await the completion of the start-up process.

4.1.6. Seek Time

The FFD has no seek time.

4.1.7. Power Requirements and Consumption

The specifications listed in Table 3 apply to all operational modes (except Secure Erase) while Termination Power (TERMPWR) is set to OFF.

The FFD input voltage is +5VDC, with a tolerance of $\pm 0.5V$.

Table 3 describes the power consumption based on capacity and disk type (80-pin connector).

Table 3: FFD 3.5" Ultra320 SCSI Power Consumption (Typical)

| Disk Capacity (GB) | Disk Type | |
|--------------------|------------------|-----------------|
| | 80-Pin Connector | |
| | Idle Mode | Read/Write Mode |
| 4 | 1.1 A 5.5 W | 1.3 A 6.5 W |
| 64 | 1.2 A 6.0 W | 1.4 A 8.4 W |
| 112 | 1.2 A 6.0 W | 1.4 A 8.4 W |
| 160 | 1.3 A 6.5 W | 1.5 A 7.5 W |
| 176 | 1.3 A 6.5 W | 1.6 A 8.0 W |
| 224 | 1.2 A 6.0 W | 1.4 A 8.4 W |
| 320 | 1.3 A 6.5 W | 1.5 A 7.5 W |
| 352 | 1.3 A 6.5 W | 1.6 A 8.0 W |

4.1.8. Memory Capacities

Table 4 describes the available capacities for the FFD.

Table 4: FFD 3.5" Ultra320 SCSI Available Capacities

| Unformatted Disk Capacity (GB) ₁ | Formatted Disk Capacity (No. of Blocks) | Cylinders | Heads | Sectors (Blocks) | Bytes/Block |
|---|---|-----------|-------|------------------|-------------|
| 1 | 1980498 | 1934 | 16 | 64 | 512 |
| 2 | 3993764 | 3900 | 16 | 64 | 512 |
| 4 | 8020296 | 7832 | 16 | 64 | 512 |
| 8 | 16073359 | 15697 | 16 | 64 | 512 |
| 12 | 24126423 | 23561 | 16 | 64 | 512 |
| 16 | 32179487 | 31425 | 16 | 64 | 512 |
| 20 | 40232550 | 39290 | 16 | 64 | 512 |

| Unformatted Disk Capacity (GB) ₁ | Formatted Disk Capacity (No. of Blocks) | Cylinders | Heads | Sectors (Blocks) | Bytes/Block |
|---|---|-----------|-------|------------------|-------------|
| 24 | 48285614 | 47154 | 16 | 64 | 512 |
| 32 | 64391741 | 62883 | 16 | 64 | 512 |
| 40 | 80497869 | 78611 | 16 | 64 | 512 |
| 48 | 96603996 | 94340 | 16 | 64 | 512 |
| 56 | 112710124 | 110068 | 16 | 64 | 512 |
| 64 | 128816251 | 125797 | 16 | 64 | 512 |
| 72 | 144922378 | 141526 | 16 | 64 | 512 |
| 80 | 161028506 | 157254 | 16 | 64 | 512 |
| 96 | 193240760 | 188712 | 16 | 64 | 512 |
| 104 | 209346888 | 204440 | 16 | 64 | 512 |
| 112 | 225453015 | 220169 | 16 | 64 | 512 |
| 120 | 241559142 | 235898 | 16 | 64 | 512 |
| 128 | 257665270 | 251626 | 16 | 64 | 512 |
| 136 | 273771397 | 267355 | 16 | 64 | 512 |
| 144 | 289877524 | 283084 | 16 | 64 | 512 |
| 152 | 305983652 | 298812 | 16 | 64 | 512 |
| 160 | 322089779 | 314541 | 16 | 64 | 512 |
| 168 | 338195907 | 330269 | 16 | 64 | 512 |
| 176 | 354302034 | 345998 | 16 | 64 | 512 |
| 192 | 386481521 | 377423 | 16 | 64 | 512 |
| 208 | 418693775 | 408881 | 16 | 64 | 512 |
| 224 | 450906030 | 440338 | 16 | 64 | 512 |
| 240 | 483118285 | 471795 | 16 | 64 | 512 |
| 256 | 515330540 | 503252 | 16 | 64 | 512 |
| 272 | 547542794 | 534710 | 16 | 64 | 512 |
| 288 | 579755049 | 566167 | 16 | 64 | 512 |
| 304 | 611967304 | 597624 | 16 | 64 | 512 |
| 320 | 644179558 | 629082 | 16 | 64 | 512 |
| 336 | 676391813 | 660539 | 16 | 64 | 512 |
| 352 | 708604068 | 691996 | 16 | 64 | 512 |

Note: Memory capacity is specified when placing device orders.

4.1.9. Endurance

The FFD supports more than 5,000,000 erase cycles and an unlimited number of read cycles, enhanced by the following features:

- **Dynamic Wear-Leveling Algorithm:** This algorithm eliminates situations where the application repeatedly writes to the same physical location until its flash components wear out. The dynamic wear leveling algorithm applies virtual mapping of logical sectors to physical blocks and is completely transparent to the customer application.
- **Garbage Collection Process:** This process eliminates the need to perform an erase operation prior to every write operation, which eliminates excessive disk deterioration. Additionally, the garbage collection process accumulates data considered necessary for erasure until the block is full.
- **EDC/ECC (Error Detection Code/Error Correction Code):** The FFD has embedded error detection and error correction hardware and software mechanisms. The EDC/ECC uses the BCH algorithm, which can detect up to 5 errors in 512 bytes of data, and correct up to 4 errors.
- **Bad-Block Mapping Algorithm:** This algorithm replaces bad blocks with new blocks from available spares.

4.1.10. Physical Characteristics

4.1.10.1 Weight

The weight of the FFD conforms to the values defined in Table 5.

Table 5: FFD 3.5" Ultra320 SCSI Weight

| Memory Capacity (GB) | Case Height (in) | Maximum Weight (g) |
|----------------------|------------------|--------------------|
| 1 – 8 | 0.5 | 25 |
| 12 – 64 | 0.5 | 275 |
| 72 – 112 | 1 | 415 |
| 120 – 160 | 1 | 480 |
| 168 – 176 | 1 | 525 |
| 192 – 224 | 1 | 415 |
| 240 – 320 | 1 | 480 |
| 336 – 352 | 1 | 525 |

4.1.10.2 Dimensions

Table 6 contains the nominal dimensions of the FFD. Refer to Figure 2 for detailed mounting configuration dimensions.

Table 6: FFD 80-pin Nominal Dimensions

| Height | Width | Depth |
|----------|-----------|-----------|
| 0.5 in | 4.00 in | 5.75 in |
| 12.70 mm | 101.60 mm | 146.05 mm |

Table 7: FFD 68-pin Nominal Dimensions

| Height | Width | Depth |
|----------|-----------|-----------|
| 0.5 in | 4.00 in | 5.75 in |
| 12.70 mm | 101.60 mm | 146.10 mm |

Note: For capacities higher than 64GB, the FFD is supplied in a 1" (25.4 mm) high raised casing.

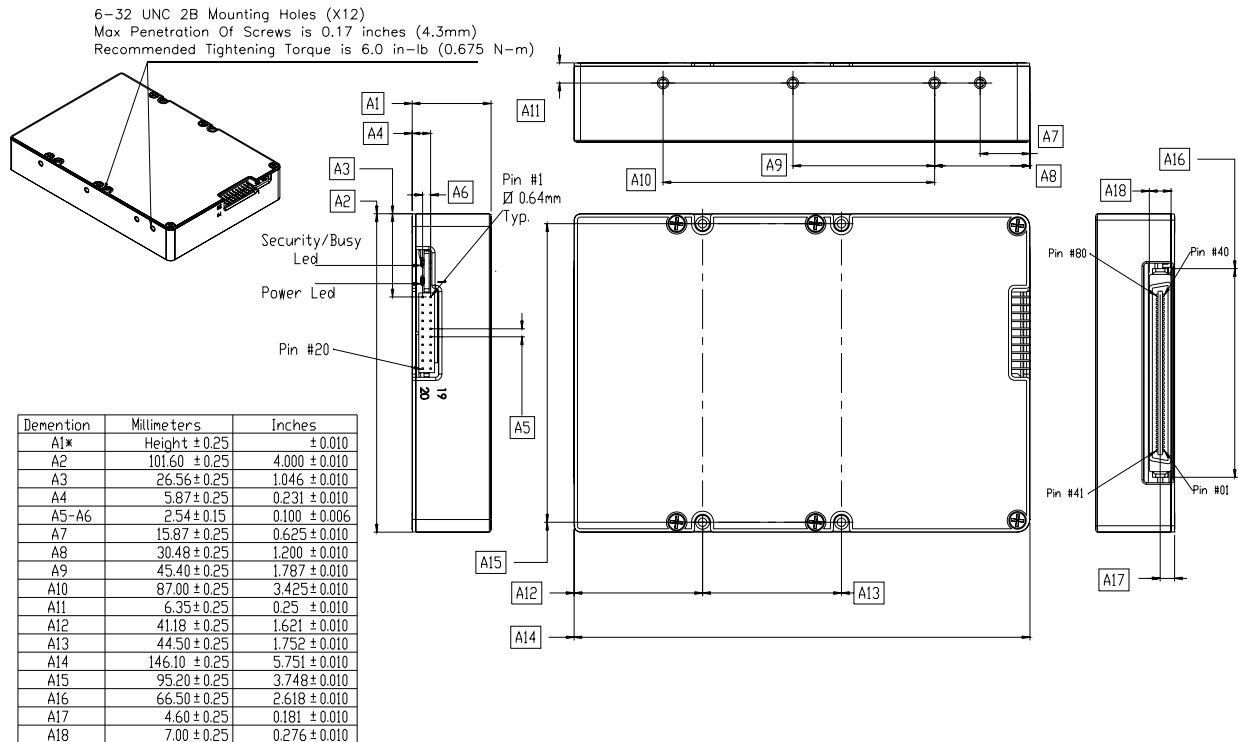

Note:
*. Dimension A1 in the drawing indicates the Unit heights, Which are available in dimensions ranging according to specification.

Figure 2: FFD 3.5" Ultra320 SCSI 80-Pin Assembly (in Inches)

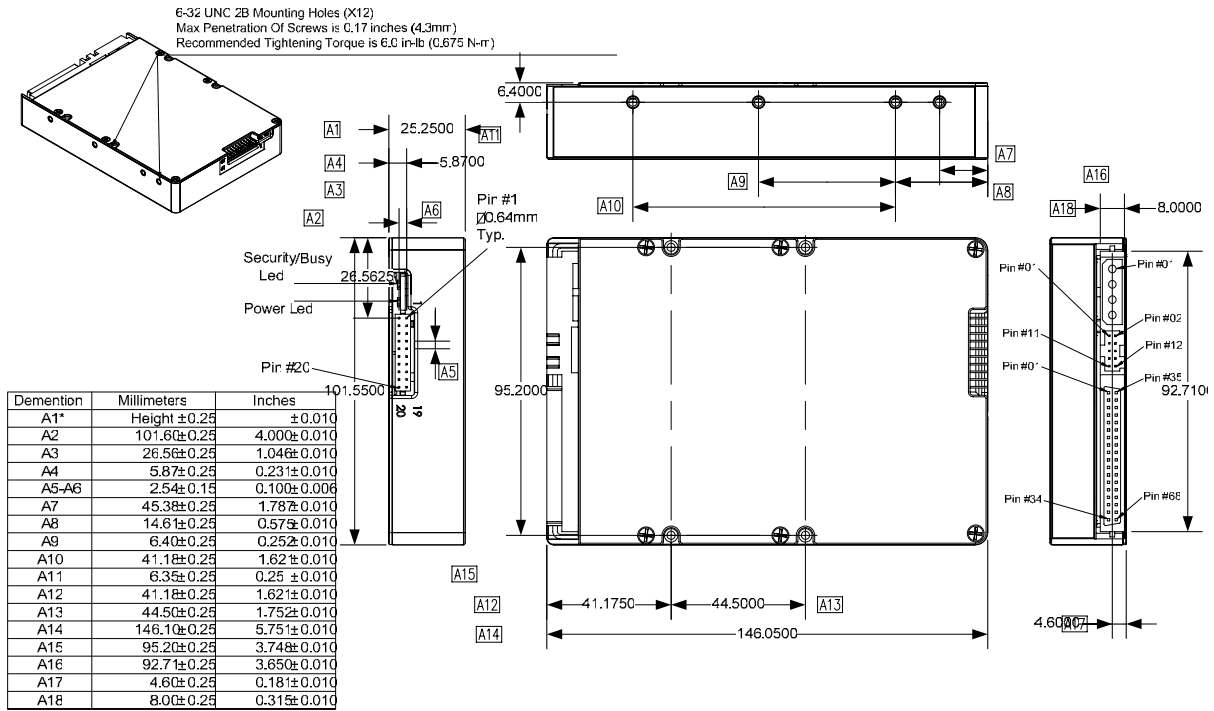

Figure 3: FFD 3.5" Ultra320 SCSI 68-Pin Assembly (in Inches)

4.1.10.3 80-Pin Connector Interface

The FFD 80-pin connector interface pinouts are described in Table 8 and Table 9, according to the electrical interface being used.

Table 8: 80-Pin Connector Pinout with Single-Ended (SE) Electrical Interface

| Pin Number | Signal Name | Pin Number | Signal Name |
|------------|-------------|------------|-------------|
| 1 | RESERVED | 41 | GROUND |
| 2 | RESERVED | 42 | GROUND |
| 3 | RESERVED | 43 | GROUND |
| 4 | RESERVED | 44 | MATED 1 |
| 5 | RESERVED | 45 | RESERVED |
| 6 | RESERVED | 46 | GROUND |
| 7 | -DB(11) | 47 | GROUND |
| 8 | -DB(10) | 48 | GROUND |
| 9 | -DB(9) | 49 | GROUND |
| 10 | -DB(8) | 50 | GROUND |
| 11 | -I/O | 51 | GROUND |
| 12 | -REQ | 52 | GROUND |
| 13 | -C/D | 53 | GROUND |

| Pin Number | Signal Name | Pin Number | Signal Name |
|------------|-------------|------------|-------------|
| 14 | -SEL | 54 | GROUND |
| 15 | -MSG | 55 | GROUND |
| 16 | -RST | 56 | GROUND |
| 17 | -ACK | 57 | GROUND |
| 18 | -BSY | 58 | GROUND |
| 19 | -ATN | 59 | GROUND |
| 20 | -DBP(0) | 60 | GROUND |
| 21 | -DB(7) | 61 | GROUND |
| 22 | -DB(6) | 62 | GROUND |
| 23 | -DB(5) | 63 | GROUND |
| 24 | -DB(4) | 64 | GROUND |
| 25 | -DB(3) | 65 | GROUND |
| 26 | -DB(2) | 66 | GROUND |
| 27 | -DB(1) | 67 | GROUND |
| 28 | -DB(0) | 68 | GROUND |
| 29 | -DBP(1) | 69 | GROUND |
| 30 | -DB(15) | 70 | GROUND |
| 31 | -DB(14) | 71 | GROUND |
| 32 | -DB(13) | 72 | GROUND |
| 33 | -DB(12) | 73 | GROUND |
| 34 | 5VDC | 74 | MATED 2 |
| 35 | 5VDC | 75 | GROUND |
| 36 | 5VDC | 76 | GROUND |
| 37 | RESERVED | 77 | ACTIVE LED |
| 38 | RESERVED | 78 | RESERVED |
| 39 | SCSI ID (0) | 79 | SCSI ID (1) |
| 40 | SCSI ID (2) | 80 | SCSI ID (3) |

Table 9: 80-Pin Connector Pinout with Low Voltage Differential (LVD) Electrical Interface

| Pin Number | Signal Name | Pin Number | Signal Name |
|------------|-------------|------------|-------------|
| 1 | RESERVED | 41 | GROUND |
| 2 | RESERVED | 42 | GROUND |
| 3 | RESERVED | 43 | GROUND |
| 4 | RESERVED | 44 | MATED 1 |
| 5 | RESERVED | 45 | RESERVED |
| 6 | RESERVED | 46 | DIFFSENS |
| 7 | -DB(11) | 47 | +DB(11) |
| 8 | -DB(10) | 48 | +DB(10) |
| 9 | -DB(9) | 49 | +DB(9) |

| Pin Number | Signal Name | Pin Number | Signal Name |
|------------|-------------|------------|-------------|
| 10 | -DB(8) | 50 | +DB(8) |
| 11 | -I/O | 51 | +I/O |
| 12 | -REQ | 52 | +REQ |
| 13 | -C/D | 53 | +C/D |
| 14 | -SEL | 54 | +SEL |
| 15 | -MSG | 55 | +MSG |
| 16 | -RST | 56 | +RST |
| 17 | -ACK | 57 | +ACK |
| 18 | -BSY | 58 | +BSY |
| 19 | -ATN | 59 | +ATN |
| 20 | -DBP(0) | 60 | +DBP(0) |
| 21 | -DB(7) | 61 | +DB(7) |
| 22 | -DB(6) | 62 | +DB(6) |
| 23 | -DB(5) | 63 | +DB(5) |
| 24 | -DB(4) | 64 | +DB(4) |
| 25 | -DB(3) | 65 | +DB(3) |
| 26 | -DB(2) | 66 | +DB(2) |
| 27 | -DB(1) | 67 | +DB(1) |
| 28 | -DB(0) | 68 | +DB(0) |
| 29 | -DBP(1) | 69 | +DBP(1) |
| 30 | -DB(15) | 70 | +DB(15) |
| 31 | -DB(14) | 71 | +DB(14) |
| 32 | -DB(13) | 72 | +DB(13) |
| 33 | -DB(12) | 73 | +DB(12) |
| 34 | 5VDC | 74 | MATED 2 |
| 35 | 5VDC | 75 | GROUND |
| 36 | 5VDC | 76 | GROUND |
| 37 | RESERVED | 77 | ACTIVE LED |
| 38 | RESERVED | 78 | RESERVED |
| 39 | SCSI ID (0) | 79 | SCSI ID (1) |
| 40 | SCSI ID (2) | 80 | SCSI ID (3) |

- Notes:
1. The 12V pins, as defined in the SCA specification (pins 1-4 on the 80-pin connector), are not required for FFD operation. These pins may be connected to a 12V power supply or left unconnected.
 2. The Activity LED is limited to 24 mA and a 100 Ω resistor.

4.1.10.4 68-Pin Connector Interface

The FFD 68-pin connector interface pinouts are described in Table 10 and Table 11, according to the electrical interface being used.

Table 10: Pinout for FFD 68-Pin Connector with Single-Ended Electrical Interface

| Pin Number | Signal Name | Pin Number | Signal Name |
|------------|-------------|------------|-------------|
| 1 | GROUND | 35 | -DB(12) |
| 2 | GROUND | 36 | -DB(13) |
| 3 | GROUND | 37 | -DB(14) |
| 4 | GROUND | 38 | -DB(15) |
| 5 | GROUND | 39 | -DBP(1) |
| 6 | GROUND | 40 | -DB(0) |
| 7 | GROUND | 41 | -DB(1) |
| 8 | GROUND | 42 | -DB(2) |
| 9 | GROUND | 43 | -DB(3) |
| 10 | GROUND | 44 | -DB(4) |
| 11 | GROUND | 45 | -DB(5) |
| 12 | GROUND | 46 | -DB(6) |
| 13 | GROUND | 47 | -DB(7) |
| 14 | GROUND | 48 | -DBP(0) |
| 15 | GROUND | 49 | GROUND |
| 16 | GROUND | 50 | GROUND |
| 17 | TERMPWR | 51 | TERMPWR |
| 18 | TERMPWR | 52 | TERMPWR |
| 19 | RESERVED | 53 | RESERVED |
| 20 | GROUND | 54 | GROUND |
| 21 | GROUND | 55 | -ATN |
| 22 | GROUND | 56 | GROUND |
| 23 | GROUND | 57 | -BSY |
| 24 | GROUND | 58 | -ACK |
| 25 | GROUND | 59 | -RST |
| 26 | GROUND | 60 | -MSG |
| 27 | GROUND | 61 | -SEL |
| 28 | GROUND | 62 | -C/D |
| 29 | GROUND | 63 | -REQ |
| 30 | GROUND | 64 | -I/O |
| 31 | GROUND | 65 | -DB(8) |
| 32 | GROUND | 66 | -DB(9) |

| Pin Number | Signal Name | Pin Number | Signal Name |
|------------|-------------|------------|-------------|
| 33 | GROUND | 67 | -DB(10) |
| 34 | GROUND | 68 | -DB(11) |

Table 11: Pinout for FFD 68-Pin Connector with Low Voltage Differential Electrical Interface

| Pin Number | Signal Name | Pin Number | Signal Name |
|------------|-------------|------------|-------------|
| 1 | +DB(12) | 35 | -DB(12) |
| 2 | +DB(13) | 36 | -DB(13) |
| 3 | +DB(14) | 37 | -DB(14) |
| 4 | +DB(15) | 38 | -DB(15) |
| 5 | +DBP(1) | 39 | -DBP(1) |
| 6 | +DB(0) | 40 | -DB(0) |
| 7 | +DB(1) | 41 | -DB(1) |
| 8 | +DB(2) | 42 | -DB(2) |
| 9 | +DB(3) | 43 | -DB(3) |
| 10 | +DB(4) | 44 | -DB(4) |
| 11 | +DB(5) | 45 | -DB(5) |
| 12 | +DB(6) | 46 | -DB(6) |
| 13 | +DB(7) | 47 | -DB(7) |
| 14 | +DBP(0) | 48 | -DBP(0) |
| 15 | GROUND | 49 | GROUND |
| 16 | DIFFSENS | 50 | GROUND |
| 17 | TERMPWR | 51 | TERMPWR |
| 18 | TERMPWR | 52 | TERMPWR |
| 19 | RESERVED | 53 | RESERVED |
| 20 | GROUND | 54 | GROUND |
| 21 | +ATN | 55 | -ATN |
| 22 | GROUND | 56 | GROUND |
| 23 | +BSY | 57 | -BSY |
| 24 | +ACK | 58 | -ACK |
| 25 | +RST | 59 | -RST |
| 26 | +MSG | 60 | -MSG |
| 27 | +SEL | 61 | -SEL |
| 28 | +C/D | 62 | -C/D |
| 29 | +REQ | 63 | -REQ |
| 30 | +I/O | 64 | -I/O |
| 31 | +DB(8) | 65 | -DB(8) |

| Pin Number | Signal Name | Pin Number | Signal Name |
|------------|-------------|------------|-------------|
| 32 | +DB(9) | 66 | -DB(9) |
| 33 | +DB(10) | 67 | -DB(10) |
| 34 | +DB(11) | 68 | -DB(11) |

4.1.11. Hot Insertion (Hot Swappable)

The following classes of hot insertion are supported by the 80-pin FFD (in accordance with the SCSI controller data sheet):

- Class 1: Power OFF during removal or insertion.
- Class 2: RST signal asserted continuously during removal or insertion.
- Class 3: Current I/O processes not permitted during insertion or removal.

4.2. Reliability

The FFD provides a very high number of hours for Mean Time Between Failures (MTBF). Exact times are capacity dependent, as described in Table 12.

Table 12: Mean Time Between Failures (MTBF) per Capacity

| Capacity (GB) | Mean Time Between Failures (Hours) |
|---------------|------------------------------------|
| 2, 4, 8 | 692,530 |
| 16, 32 | 468,648 |
| 64 | 313,499 |
| 112, 224 | 202,610 |
| 160, 320 | 149,669 |
| 176, 352 | 135,662 |

Performance assessments are based on Telcordia SR-332, GB, 25°C. A detailed MTBF report can be provided upon customer request.

4.3. Embedded Error Detection and Error Correction Code (EDC/ECC)

The FFD has embedded error detection and error correction hardware and software mechanisms. The EDC/ECC uses the BCH algorithm, which can detect up to 5 errors in 512 bytes of data, and correct up to 4 errors.

4.4. Environmental Conditions

The FFD complies with the performance requirements specified herein after exposure to non-operating environmental conditions, or during and after exposure to operating environmental conditions.

4.4.1. Temperature

The FFD operates without degradation at 1 atmosphere in the following air temperature ranges:

- Commercial temperature version: 0°C to +70°C
- Enhanced temperature version: -25°C to +75°C
- Extended temperature version: -40°C to +85°C

The FFD meets the performance requirements specified herein after withstanding exposure to a nominal ambient temperature of -40°C for not less than 3 days, and of +85°C for a period of not less than 6 hours.

- Storage temperature range: -55°C to +95°C

4.4.2. Altitude

The FFD operates at altitudes ranging from sea level to 80,000 ft, and withstands air transportation in non-pressurized flights at altitudes of up to 80,000 ft.

4.4.3. Relative Humidity

The FFD can withstand 5% to 95% non-condensing relative humidity.

4.4.4. Shock

The FFD operates as specified after being subjected to shock testing under the following conditions:

- 50 G half-sine pulses for 11 ms
and
- 1,500 G half-sine pulses for 0.5 ms

Shock testing was performed according to the MIL-STD-810F standard. A detailed testing report is available for download from the M-Systems website.

4.4.5. Vibration

The FFD operates as specified without degradation when subjected to the following vibration conditions:

- 16.3G RMS (random, 20 Hz to 2000 Hz, 3 axes of vibration)

Vibration testing was performed according to the MIL-STD-810F standard. A detailed testing report is available for download from the M-Systems website.

4.5. Compliance with Standards

The FFD is guaranteed to comply with CE, UL and FCC Class B (EMI/EMC) standards as follows:

CE, UL, EN 55022 Class B, CISPR 22 Class B, AS/NZS 3548 Class B, BSMI CNS 13438 Class B, CAN/CSA-V-3/2001.04 (VCCI), FCC Part 15 Class B, EN 61000-3-2, EN 61000-3-3, IEC 61000-4-2/3/4/5/6/8/11, MIL-STD-810F.



Figure 4: Logos of Applicable Standards

4.6. Access/Activity LED

FFD has a green access/activity LED on the front of the unit. The LED lights during power-up, diagnostic operations, and whenever the disk is performing commands.

5. SUPPORTED SCSI COMMANDS

The FFD supports the SCSI commands listed in Table 13.

Table 13: SCSI Commands

| Command | Option ¹ | Command Code |
|---|---------------------|--------------|
| Group 0: 6-Byte Commands | | |
| TEST UNIT READY | M | 0x00 |
| REZERO UNIT | O ² | 0x01 |
| REQUEST SENSE | M | 0x03 |
| FORMAT UNIT | M | 0x04 |
| REASSIGN BLOCKS | O | 0x07 |
| READ(6) | M | 0x08 |
| WRITE(6) | O | 0x0A |
| SEEK(6) | O ¹ | 0x0B |
| INQUIRY | M | 0x12 |
| MODE SELECT(6) | O | 0x15 |
| RESERVE(6) | M ³ | 0x16 |
| RELEASE(6) | M | 0x17 |
| MODE SENSE(6) | O | 0x1A |
| START/STOP UNIT | O | 0x1B |
| SEND DIAGNOSTICS | M | 0x1D |
| Groups 1 and 2: 10-Byte Commands | | |
| READ CAPACITY | M | 0x25 |
| READ(10) | M | 0x28 |
| WRITE(10) | O | 0x2A |
| SEEK(10) | O | 0x2B |
| WRITE AND VERIFY(10) | O | 0x2E |
| VERIFY(10) | O | 0x2F |
| READ DEFECT DATA(10) | O | 0x37 |
| SYNCHRONIZE CACHE (10) | O | 0x35 |
| WRITE BUFFER | O | 0x3B |
| CHANGE DEFINITION | O | 0x40 |
| MODE SELECT(10) | O | 0x55 |
| MODE SENSE(10) | O | 0x5A |

| Command | Option ¹ | Command Code |
|--|---------------------|--------------|
| Vendor-Specific: 6-Byte Commands | | |
| SECURE ERASE | V | 0xDF |
| Vendor-Specific: 10-Byte Commands | | |
| SANITIZE NEW FORMAT | V | 0xFF |

1. M=Mandatory
 O = Optional
 V = Vendor Specific
2. REZERO UNIT and SEEK(6) are obsolete in SCSI-3, but are supported by the FFD for compatibility with SCSI-2.
3. In SCSI-3 fields 3rd Party and 3rd Party Device ID are obsolete in RESERVE(6) and RESERVE(6) commands, but are supported by the FFD for compatibility with SCSI-2.

6. SCSI MESSAGES

The FFD indicates its ability to respond to SCSI messages by responding to the ATN signal with a change to the MESSAGE OUT phase. Table 14 describes the supported SCSI messages.

Table 14: SCSI Message Codes

| Status | Code | Direction (Relative to the Initiator) |
|-----------------------------------|----------------|---------------------------------------|
| COMMAND COMPLETE | 0h | In |
| ABORT TASK SET | 6h | Out |
| INITIATOR DETECTED ERROR | 5h | Out |
| MESSAGE PARITY ERROR | 9h | Out |
| MESSAGE REJECT | 7h | In/Out |
| NO OPERATION | 8h | Out |
| BUS DEVICE RESET | 0Ch | Out |
| ABORT TASK | 0Dh | Out |
| CLEAR TASK SET | 0Eh | Out |
| IGNORE WIDE RESIDUE | 23h | Out |
| IDENTIFY | 80h - FFh | Out |
| SYNCHRONOUS DATA TRANSFER REQUEST | 01h (extended) | In/Out |
| WIDE DATA TRANSFER REQUEST | 01h (extended) | In/Out |
| PARALLEL PROTOCOL REQUEST | 01h (extended) | In/Out |

7. PACKETIZED SCSI

The FFD supports the Packetized SCSI protocol, as described in the SPI-4 standard (supports all the necessary information units).

The SPI-4 standard outlines the following new features:

- Paced data transfer: Packetized SCSI
- Free-running clock (ACK, REQ, and P1 for valid data)
- ISI (Intersymbol Interference) Compensation: Precomp drivers and Adaptive Active Filter receivers
- Skew compensation
- Training pattern for Adaptive Active Filters and skew compensation

8. VENDOR-SPECIFIC COMMANDS

8.1. Security Erase Features

The vendor-specific Security Erase feature quickly erases all selected media on the FFD. The SCSI vendor-specific (command codes 0xDFh and 0xFFh) or the vendor-specific Security Erase hardware interrupt (offered as an option upon customer request) activates this function.

When the Security Erase function is activated, all NAND flash (for Full Security Erase, as described in Section 8.1.1), or part of the NAND flash components (for Partial Security Erase, as described in Section 8.1.2) are erased. The FFD Secure Erase option can also be configured to fill the erased part of the media immediately after the erase process is complete. Bad blocks and unused flash storage are erased as well.

8.1.1. Full Security Erase Option

When the Full Security Erase function is activated, all NAND flash components are erased.

To make the FFD fully operational after the completion of the Full Security Erase process, the FFD must be power cycled.

This function is identical to the previously available feature in the FFD product line.

8.1.2. Partial Security Erase Option

When a Partial Security Erase is initiated, only selected parts of the media are erased. The unselected parts of the media remain intact.

The FFD must be power cycled to become fully operational after the completion of the Partial Security Erase process. Since it is not possible to perform a low-level format on only part of the media, it is strongly recommended to use the Fill-Format option, as described in Section 8.2.

Users can define up to eight areas/partitions on the FFD media. Each area has the following attributes:

- Partition number (0 - 7).
- A **To Be Erased** flag (0 = Do not erase this partition, 1 = Erase this partition).
- Start and End sector boundaries (boundaries included).

When the Partial Security Erase feature is activated via the vendor-specific security erase hardware interrupt and the partial Security Erase is set to ON, only those partitions with the To Be Erased flag set to 1 are erased.

When the Partial Security Erase feature is activated via the SCSI vendor-specific command, the user may select whether to erase the designated partitions, or whether to override the designated parameters and set different partitions to be erased.

When a sector resides in overlapping partitions where one partition is set to be erased and one is set to remain intact, the partition plus the part of the sector that overlaps will be erased.

8.1.3. Resume Option

If the power is interrupted while Security Erase is in process, part of the media may remain intact. The FFD provides a Resume option that restarts Security Erase on the next power up. The Resume option persists until the security erase is complete.

The Resume option is user configurable. This feature default is ON.

8.1.4. Fill-Format Option

The Fill-Format option automatically writes the erased media. This process can replace the low-level format process, and is strongly recommended after the Partial Security Erase because it is the only way to perform a partial low-level format of the media. The Fill-Format option should not replace the low-level format process if a quick-sanitizing process is used.

Erasing the media without either the fill-format option or low-level formatting will result in a longer mount time.

8.1.5. Configuration

8.1.5.1 Configurable Parameters

The following parameters can be configured:

- **Disable/Enable Resume Security Erase:** If this flag is disabled and power is interrupted while Security Erase is in progress, the FFD will not restart Security Erase on the next power up. This flag is enabled by default.
- **Disable/Enable Partial Security Erase:** If this flag is enabled, Partial Secure Erase is activated and only the designated partitions are erased during the Security Erase process. If this flag is disabled (default) all media is erased. When activating Security Erase via the SCSI vendor-specific command, the user may override this flag.
- **Fill-Format Media:** Select if and how to fill-format the erased media after Security Erase. If the Fill-Format option is OFF, the user must low-level format the FFD after Security Erase. The fill options are as follows:
 - o Fill = 1: No fill (default)
 - o Fill = 2: Fill with zeros
 - o Fill = 3: Fill with random pattern
- **Partition configuration:** Up to eight partitions may be set. Each partition contains the following information:
`<Partition number (0-7) > <Partition on/off (0/1)> <Start Sector>
<End Sector>`

8.1.5.2 Configuring with Standard SCSI WRITE BUFFER Commands

All Security Erase parameters are configured via the SCSI WRITE BUFFER command.

Table 15: Disable/Enable Resume Security Erase (on Power-Up)

| Byte | Bit | | | | | | | | | | | | | | | | | | | | | | | |
|------|------------------------------|---|---|----------|---|---|-------------|---|-----|--|--|--|--|--|--|--|-----|--|--|--|--|--|--|--|
| | 7 | 6 | 5 | 4 | 3 | 2 | 1 | 0 | | | | | | | | | | | | | | | | |
| 0 | Operation Code = 0x3B | | | | | | | | | | | | | | | | | | | | | | | |
| 1 | Logical Unit Number | | | Reserved | | | Mode = 0x01 | | | | | | | | | | | | | | | | | |
| 2 | Reserved (0x00) | | | | | | | | | | | | | | | | | | | | | | | |
| 3 | Buffer Offset = 0x0B | | | | | | | | | | | | | | | | | | | | | | | |
| 4 | | | | | | | | | LSB | | | | | | | | | | | | | | | |
| 5 | | | | | | | | | | | | | | | | | MSB | | | | | | | |
| 6 | Parameter List Length = 0x01 | | | | | | | | | | | | | | | | | | | | | | | |
| 7 | | | | | | | | | LSB | | | | | | | | | | | | | | | |
| 8 | | | | | | | | | | | | | | | | | MSB | | | | | | | |
| 9 | | | | | | | | | | | | | | | | | | | | | | | | |

For example, the SCSI commands for enabling/disabling the resume option are:

```
3b 01 00 00 00 0b 00 00 01 00
```

The disable/enable resume security erase data structure to be transferred contains one byte, as described in Table 16.

Table 16: Disable/Enable Resume Security Erase Data Structure

| Byte | Bit | | | | | | | |
|------|----------|---|---|---|---|---|---|--------|
| | 7 | 6 | 5 | 4 | 3 | 2 | 1 | 0 |
| 0 | Reserved | | | | | | | Resume |

A Resume bit of 1 enables resuming Security Erase on power-up. A Resume bit of 0 disables the resume option on power-up (see Section 8.1.5.1).

Table 17: Disable/Enable Partial Security Erase

| Byte | Bit | | | | | | | | | | | | | | | |
|------|-----------------------|---|---|----------|---|---|-------------|---|-----|--|--|--|--|--|--|--|
| | 7 | 6 | 5 | 4 | 3 | 2 | 1 | 0 | | | | | | | | |
| 0 | Operation Code = 0x3B | | | | | | | | | | | | | | | |
| 1 | Logical Unit Number | | | Reserved | | | Mode = 0x01 | | | | | | | | | |
| 2 | Reserved (0x00) | | | | | | | | | | | | | | | |
| 3 | Buffer Offset = 0x14 | | | | | | | | | | | | | | | |
| 4 | | | | | | | | | LSB | | | | | | | |
| 5 | | | | | | | | | | | | | | | | |

| Byte | Bit | | | | | | | |
|------|------------------------------|---|---|---|---|---|---|---|
| | 7 | 6 | 5 | 4 | 3 | 2 | 1 | 0 |
| 6 | Parameter List Length = 0x01 | | | | | | | |
| 7 | | | | | | | | |
| 8 | | | | | | | | |
| 9 | Control | | | | | | | |

For example, the SCSI commands for enabling/disabling Partial Security Erase are:

```
3b 01 00 00 00 14 00 00 01 00
```

The disable/enable Partial Security Erase data structure to be transferred contains one byte, as described in Table 18.

Table 18: Disable/Enable Partial Security Erase Data Structure

| Byte | Bit | | | | | | | |
|------|----------|---|---|---|---|---|---|---------|
| | 7 | 6 | 5 | 4 | 3 | 2 | 1 | 0 |
| 0 | Reserved | | | | | | | Partial |

A Partial bit of 1 enables partial security erase on power-up.

A Partial bit of 0 disables partial security erase on power-up.

Table 19: Setting the Boundaries

| Byte | Bit | | | | | | | |
|------|-----------------------|---|---|----------|---|---|------------|---|
| | 7 | 6 | 5 | 4 | 3 | 2 | 1 | 0 |
| 0 | Operation Code = 0x3B | | | | | | | |
| 1 | Logical Unit Number | | | Reserved | | | Mode = 0x1 | |
| 2 | Reserved (0x00) | | | | | | | |
| 3 | Buffer Offset = 0x13 | | | | | | | |
| 4 | | | | | | | | |
| 5 | | | | | | | | |
| 6 | Parameter List Length | | | | | | | |
| 7 | | | | | | | | |
| 8 | | | | | | | | |
| 9 | Control | | | | | | | |

Bit Description

- Operation Code: 3Bh
- Mode 0x1: Vendor-specific mode
- Buffer Offset: 0x13.

- Parameter List Length: Specifies the length of the transfer. Each partition requires 12 bytes in the data structure to be transferred:
 - o 2 bytes for the partition number
 - o 2 bytes to indicate whether Security Erase has been set for this partition (1 = ERASE ON)
 - o 4 bytes for the start sector of the partition (hexadecimal number)
 - o 4 bytes for the end sector of the partition (hexadecimal number)

Table 20: Partition Structure

| Byte | Bit | | | | | | | | |
|------|------------------|---|---|---|---|---|---|--------------|-----|
| | 7 | 6 | 5 | 4 | 3 | 2 | 1 | 0 | |
| 0 | Partition number | | | | | | | | |
| 1 | | | | | | | | | |
| 2 | Reserved | | | | | | | | |
| 3 | Reserved | | | | | | | To Be Erased | |
| 4 | Start Sector | | | | | | | | |
| 5 | | | | | | | | | MSB |
| 6 | | | | | | | | | LSB |
| 7 | | | | | | | | | |
| 8 | End Sector | | | | | | | | |
| 9 | | | | | | | | | MSB |
| 10 | | | | | | | | | LSB |
| 11 | | | | | | | | | |

For example, to set partition 0 from sector 0 to sector 16383 (0x3FFF) to remain intact and partition 1 from sector 16384 (0x4000) to sector 32767 (0x7FFF) to be erased, the SCSI command is:

3b 01 00 00 00 13 00 00 18 00

The data structure to be transferred for the above configuration is illustrated in Figure 5.

| | | | | | | | | | | | | |
|----|----|----|----|----|----|----|----|----|----|----|----|----|
| 00 | 00 | 00 | 00 | 00 | 00 | 00 | 00 | 00 | 00 | 00 | 3F | FF |
| 00 | 01 | 00 | 01 | 00 | 00 | 40 | 00 | 00 | 00 | 00 | 7F | FF |

Figure 5: Example Data Structure

8.1.5.3 Reading Security Erase Parameters

Table 21 describes the configuration for reading the boundaries of the Security Erase parameters.

Table 21: Reading the Boundaries

| Byte | Bit | | | | | | | |
|------|------------------------------------|---|---|----------|---|------------|---|---|
| | 7 | 6 | 5 | 4 | 3 | 2 | 1 | 0 |
| 0 | Operation Code = 0x3C | | | | | | | |
| 1 | Logical Unit Number | | | Reserved | | Mode = 0x1 | | |
| 2 | Reserved (0x00) | | | | | | | |
| 3 | MSB Buffer Offset = 0x13 LSB | | | | | | | |
| 4 | | | | | | | | |
| 5 | | | | | | | | |
| 6 | MSB Allocation length LSB | | | | | | | |
| 7 | | | | | | | | |
| 8 | | | | | | | | |
| 9 | Control | | | | | | | |

Bit Description

- Operation Code: 3Ch
- Mode 0x1: Vendor-specific mode
- Buffer Offset: 0x13
- Allocation length: Specifies the length of the transfer. Each partition requires 12 bytes. The first four bytes of the received data contain the read length, therefore the transfer length is $(\text{NUMBER_OF_PARTITIONS_TO_READ} \times 12) + 4$

The first four bytes of the data structure to be received indicate the length of the received data. All following bytes are the partition information.

For example, to read all the data, the user should enter 100 (64 HEX) as the allocation length ($12 \times 8 + 4$). The SCSI command is:

```
3C 01 00 00 00 13 00 00 64 00
```

The data structure received for the entire security erase partition information is illustrated in Figure 6.

| | | | | | | | | | | | |
|----|----|----|----|----|----|----|----|----|----|----|----|
| 00 | 00 | 00 | 60 | | | | | | | | |
| 00 | 00 | 00 | 00 | 00 | 00 | 00 | 00 | 00 | 00 | 00 | 00 |
| 00 | 01 | 00 | 00 | 00 | 00 | 00 | 00 | 00 | 00 | 00 | 00 |
| 00 | 02 | 00 | 00 | 00 | 00 | 00 | 00 | 00 | 00 | 00 | 00 |
| 00 | 03 | 00 | 00 | 00 | 00 | 00 | 00 | 00 | 00 | 00 | 00 |
| 00 | 04 | 00 | 00 | 00 | 00 | 00 | 00 | 00 | 00 | 00 | 00 |
| 00 | 05 | 00 | 00 | 00 | 00 | 00 | 00 | 00 | 00 | 00 | 00 |
| 00 | 06 | 00 | 00 | 00 | 00 | 00 | 00 | 00 | 00 | 00 | 00 |
| 00 | 07 | 00 | 00 | 00 | 00 | 00 | 00 | 00 | 00 | 00 | 00 |

Figure 6: Data Structure for Reading 0x64 Bytes

8.1.5.4 Sanitize Configuration Commands

Table 22: Sanitize Configuration Commands

| Byte | Bit | | | | | | | |
|------|------------------------------------|---|---|----------|---|---|------------|---|
| | 7 | 6 | 5 | 4 | 3 | 2 | 1 | 0 |
| 0 | Operation Code = 0x3C | | | | | | | |
| 1 | Logical Unit Number | | | Reserved | | | Mode = 0x1 | |
| 2 | Reserved (0x00) | | | | | | | |
| 3 | MSB Buffer Offset = 0x23 LSB | | | | | | | |
| 4 | | | | | | | | |
| 5 | | | | | | | | |
| 6 | MSB 0x05 LSB | | | | | | | |
| 7 | | | | | | | | |
| 8 | | | | | | | | |
| 9 | Control | | | | | | | |

8.1.5.5 Data Length is 5 Bytes

Table 23: Data Length is 5 Bytes

| Byte | Bit | | | | | | | |
|------|----------------|---|---|---|---|---|---|---|
| | 7 | 6 | 5 | 4 | 3 | 2 | 1 | 0 |
| 0 | Master Command | | | | | | | |
| 1 | Parameter 1 | | | | | | | |
| 2 | Parameter 2 | | | | | | | |
| 3 | Parameter 3 | | | | | | | |
| 4 | IRIG | | | | | | | |

8.1.5.6 Vendor-Specific Security Erase SCSI Command

The vendor-specific SCSI command can be used to bypass the default Security Erase parameters that are defined in the security erase configuration.

There are two commands that perform security erase/sanitize: 0xDF (an old method included for backward compatibility with old products) and the more flexible 0xFF, which is strongly recommended.

Table 24: Security Erase Command, New Structure

| Byte | Bit | | | | | | | |
|------|-----------------------|---|---|-----------|---|---|---|---|
| | 7 | 6 | 5 | 4 | 3 | 2 | 1 | 0 |
| 0 | Operation Code = 0xFF | | | | | | | |
| 1 | LUN | | | 0x0A/0x0B | | | | |
| 2 | Parameter 3 | | | | | | | |
| 3 | Parameter 2 | | | | | | | |
| 4 | Parameter 1 | | | | | | | |
| 5 | Master Command | | | | | | | |
| 6 | Reserved | | | | | | | |
| 7 | Reserved | | | | | | | |
| 8 | Erase Mask | | | | | | | |
| 9 | Control | | | | | | | |

The Sanitize command provides a high degree of flexibility, which enables executing declassification procedures defined in various standards by providing different arguments to the command. Specifically, the Sanitize command enables defining up to three stages of the declassification process, where each stage can be either erasing the media and overwriting it with a given character, or erasing the media and filling it with random information a specified number of times.

If the number of erase-fill cycles is 0, the Sanitize command performs a complete erase but does not fill the media. This is the fastest option; and is also known as the Security Erase option.

The default Sanitize procedure is factory-preset to the Security Erase option (erase the media without media fill).

The Master Command has the following layout:

- Bits 6-7: Subcommand selection
 - o Value of 00b: Execute default Sanitize procedure
 - o Value of 01b: Execute 1 subcommand, defined in bits 0-1
 - o Value of 10b: Execute 2 subcommands, defined in bits 0-1 and 2-3
 - o Value of 11b: Execute 3 subcommands, defined in bits 0-1, 2-3, and 4-5

Attempting to save the default Sanitize configuration (option **D**) using subcommand selection 00b will result in an aborted command and no changes will be made.

When the Master Command specifies only 1 or 2 subcommands, parameters for the remaining subcommands are reserved and should be set to 0 for compatibility with future versions.

For the default Sanitize procedure, all other bits in the Master Command and parameters 1-3 are reserved and should be set to 0 for compatibility with future versions.

Bits 0-1, 2-3, and 4-5 of the Master Command contain the following subcommands:

- Value of 0: Erase and fill with given character. The character is provided in the corresponding parameter.
- Value of 1: Erase and fill with random data, several times. The number of erase/fill loops is provided in the corresponding parameter. Zero number of loops means erase once and do not fill. Only the 7 least significant bits in the parameter are used to specify the number of loops. The most significant bit is reserved for future extensions.
- Value of 2 or 3: These subcommands are reserved for future extensions.
 Parameter1 corresponds to the subcommand in bits 0-1.
 Parameter2 corresponds to the subcommand in bits 2-3.
 Parameter3 corresponds to the subcommand in bits 4-5.

The Partition Mask is either a bitmap of partitions to be sanitized or value 0. In bitmap mode, least-significant bit 1 corresponds to partition 0. Value of zero is a special value; it corresponds to sanitizing the whole media regardless of partition configuration.

For example:

- o Value of 0xF (or 1111 binary) corresponds to sanitizing of all 4 partitions
- o Value of 0x8 (or 1000 binary) corresponds to sanitizing partition number 3
- o Value of 0x1 (or 0001 binary) corresponds to sanitizing partition number 0
- o Value of 0x5 (or 0101 binary) corresponds to sanitizing partitions 0 and 2
- o Value of 0 (or 0000 binary) corresponds to sanitizing the whole media

Table 25: Sanitize Procedure Options

| Operation | Master Command | Parameter1 | Parameter2 | Parameter3 |
|--|----------------|------------|------------|------------|
| Execute the default Sanitize procedure. | 0x00 | 0x00 | 0x00 | 0x00 |
| Erase the media (Security Erase). | 0x41 | 0x00 | 0x00 | 0x00 |
| <i>USA-AF AFSSI 5020</i> Erase the media and overwrite with random data. | 0x41 | 0x01 | 0x00 | 0x00 |
| <i>USA Navy NAVSO P-5239-26</i> Erase the media and overwrite with random data, then erase again. | 0x85 | 0x01 | 0x00 | 0x00 |

| Operation | Master Command | Parameter1 | Parameter2 | Parameter3 |
|--|----------------|------------|------------|------------|
| <i>DoD 5220.22-M</i> Erase the media and overwrite with single character, then erase again. | 0x84 | Char | 0x00 | 0x00 |
| <i>NSA Manual 130-2</i> Erase the media and overwrite with random data 2 times, then erase and overwrite with a character. | 0x81 | 0x02 | Char | 0x00 |
| <i>USA-Army 380-19</i> Erase the media and overwrite with random data, erase and overwrite with a character, then erase and overwrite with complement of the character. | 0xC1 | 0x01 | Char | ~Char |
| <i>NISPOMSUP Chap 8, Sect. 8-501</i> Overwrite all locations with a character, its complement, and then random data. | 0xD0 | Char | ~Char | 0x01 |
| <i>IREC (IRIG) 106:</i> Erase the media, overwrite with 0x55, erase, overwrite with 0xAA, erase. | 0xD0 | 0x55 | 0xAA | 0x00 |
| Erase the media and overwrite with random data (different data each time) 21 times. | 0x41 | 0x15 | 0x00 | 0x00 |
| Erase the media and overwrite with random data (different data each time) 381 times | 0xD5 | 0x7F | 0x7F | 0x7F |

8.1.5.7 Erase Mask

Table 26: Erase Mask Data Structure

| Byte | Bit | | | | | | | |
|------|-------------|-------------|-------------|-------------|-------------|-------------|-------------|-------------|
| | 7 | 6 | 5 | 4 | 3 | 2 | 1 | 0 |
| 0 | Partition 7 | Partition 6 | Partition 5 | Partition 4 | Partition 3 | Partition 2 | Partition 1 | Partition 0 |

8.1.6. Verifying Security Erase

Upon request, M-Systems provides a special utility that verifies Security Erase. Please contact your M-Systems representative for more information.

8.1.7. Sanitizing Based on DoD 5220.22-M

The USA DoD 5220.22-M National Industrial Security Program Operating Manual (NISPOM), January 1995, specifies the sanitization processes for each media type (in order to be considered declassified) in Chapter 8, Automated Information System Security. For the flash EPROM media type, the sanitization process is as follows:

- “Overwrite all addressable locations with a single character.”

Then

- “Perform a full chip erase as per manufacturer’s data sheet.”

M-Systems’ enhanced Security Erase feature complies with the above requirements, as follows:

- Activate the Fill-Format option, set to fill the media with zeros (see Sections 8.1.4 and 8.1.5).

Then

- Perform a full Security Erase (see Section 8.1.1).

8.1.8. Sanitizing Based on NSA Manual 130-2

The USA National Security Agency (NSA) specifies the procedure for sanitizing semiconductor memory devices in its 130-2 Media Declassification and Destruction Manual (Paragraph 5, Section 7). Flash components fit the Electrically Erasable Programmable Memory (EEPROM) category, and sanitizing is performed as follows (excerpted from the 130-2 Media Declassification and Destruction Manual):

- “Pulse the erase control gate and verify the erasure.”

Then

- “Overwrite all bit locations with arbitrary unclassified data.”

M-Systems’ enhanced Security Erase feature complies with the above requirements, as follows:

- Perform a full Security Erase (see Section 8.1.1).

Then

- Activate the Fill-Format option, set to fill the media with a random pattern (see Sections 8.1.4 and 8.1.5).

8.1.9. Sanitizing Based on USA Air Force AFSSI 5020

The USA Air Force System Security Instruction (AFSSI) 5020, dated 20 August, 1996, specifies the procedure for sanitizing confidential media. Chapter 5, Semiconductor Devices, describes the security procedure for all types of semiconductor media. In paragraph 5.3, the procedure for sanitizing flash memory is described as follows:

- “Pulsing the erase control gate and verifying the erasure.”
Then
- “Overwrite all bit locations with arbitrary unclassified data.”

M-Systems’ enhanced Security Erase feature complies with the above requirements, as follows:

- Perform a full Security Erase (see Section 8.1.1).
Then
- Activate the Fill-Format option, set to fill the media with a random pattern (see Sections 8.1.4 and 8.1.5).

8.1.10. Sanitizing (Purging) Based on USA Army Regulation 380-19

The USA Army Regulation 380-19, Information Systems Security (ISS), effective 27 March, 1998, provides the security requirements for systems processing Special Access Program (SAP) information and describes the ISS policy as it applies to security in hardware, software procedures, telecommunication, personal use, physical environment, networks and firmware. Section VII, Automated Information System Media, Section 2-20, describes cleaning, purging, declassifying and destroying media. Appendix F-2 describes the following for sanitizing Flash EPROM (FEPRM):

- “Overwrite all locations with a random character, a specific character, then its complement.”
Then
- “Check with the DAA (Designated Approval Authority)/SCO (Service Certifying Organization) to see if additional procedures are required.”

M-Systems’ enhanced Security Erase feature complies with the above requirements, as follows:

- Activate the Fill-Format option, set to fill the media with a random pattern (see Sections 8.1.4 and 8.1.5).
Then
- Activate the Fill-Format option again, set to fill the media with zeros (see Sections 8.1.4 and 8.1.5).
Then
- Perform a full Security Erase, which fills the media with ones (see Section 8.1.1).

8.1.11. Sanitizing (Purging) Based on USA Navy NAVSO P-5239-26

The Navy Staff Office Publication (NAVSO) 5239, “Information Systems Security (INFOSEC) Program Guidelines” is issued by the Naval Information Systems Management Center and provides policy, guidelines, and procedures for clearing and purging computer system memory and other storage media for release outside of and for reuse within controlled environments. It pertains to both classified and sensitive unclassified information, and implements DOD 5200.28-M and CSC-STD-005-85. Chapter 3 describes the cleaning and purging of data storage media, and section 3.5 describes the purging of EEPROM and EAROM. To purge EEPROM:

- ”Overwrite all locations with any pattern.”

M-Systems’ enhanced Security Erase feature complies with the above requirements, as follows:

- Activate the Fill-Format option, set to fill the media with a random pattern (see Sections 8.1.4 and 8.1.5).

Then

- Perform a full Security Erase (see Section 8.1.1).

8.1.12. Declassification Based on IRIG-106 (NTISSP-9)

The Telemetry Group (TG) of the Range Commanders Council (RCC) has prepared documents to foster the compatibility of telemetry transmitting, receiving, and signal processing equipment at the member ranges under the cognizance of the RCC.

IRIG (Inter-Range Instrumentation Group) 106 are set of Telemetry standards which provide the necessary criteria on which to base equipment design and modification.

The National Telecommunication & Information Security Systems (NTISSP-9) Chapter 10 describes the requirements for SOLID STATE RECORDER STANDARD. Section 10.8 (declassification) addresses declassification for various Solid-State Disks as follows:

- First Erase – Every memory block on the board is erased
- First write 0x55 – Every memory chip location is recorded with a pattern 0x55
- Second Erase – Every memory block on the board is erased
- Second write 0xAA – Every memory chip location is recorded with a pattern 0xAA
- Third Erase – Every memory block on the board is erased

IRIG106 chapter 10 requires keeping all *failed to erase* and *failed to write* blocks in tables, and enabling the user to read the data in these tables.

The commands described below are available to support this requirement.

Table 27: Read Number of Blocks that Failed to Erase/Write and Block Numbers

| Byte | Bit | | | | | | | |
|------|--|---|---|----------|-------|-----|---|---|
| | 7 | 6 | 5 | 4 | 3 | 2 | 1 | 0 |
| 0 | Operation Code = 0x37 READ_DEFECT_DATA | | | | | | | |
| 1 | LUN | | | Reserved | | | | |
| 2 | Reserved | | | Plist | Glist | 0x7 | | |
| 3 | Reserved | | | | | | | |
| 4 | Reserved | | | | | | | |
| 5 | Reserved | | | | | | | |
| 6 | Reserved | | | | | | | |
| 7 | Allocation Length MSB | | | | | | | |
| 8 | Allocation Length LSB | | | | | | | |
| 9 | Control | | | | | | | |

Table 28: Reply Format

| Byte | Bit | | | | | | | |
|------|----------------------------------|---|---|-------|-------|-----|---|---|
| | 7 | 6 | 5 | 4 | 3 | 2 | 1 | 0 |
| 0 | Reserved | | | | | | | |
| 1 | Reserved | | | Plist | Glist | 0x7 | | |
| 2 | Number failed blocks MSB | | | | | | | |
| 3 | Number failed blocks LSB | | | | | | | |
| 4 | Block Size MSB | | | | | | | |
| 5 | Block size high mid byte | | | | | | | |
| 6 | Block size low mid byte | | | | | | | |
| 7 | Block Size LSB | | | | | | | |
| 8 | First block number MSB | | | | | | | |
| 9 | First block number high mid byte | | | | | | | |
| 10 | First block number low mid byte | | | | | | | |
| 11 | First block number LSB | | | | | | | |
| 12 | | | | | | | | |

Table 29: Get Sanitize Failed Data

| Byte | Bit | | | | | | | |
|------|-----------------------|---|---|----------|---|---|---|----------|
| | 7 | 6 | 5 | 4 | 3 | 2 | 1 | 0 |
| 0 | Operation Code = 0x51 | | | | | | | |
| 1 | LUN | | | Reserved | | | | Sub code |
| 2 | Block number MSB | | | | | | | |
| 3 | Block number mid high | | | | | | | |
| 4 | Block number mid low | | | | | | | |
| 5 | Block number LSB | | | | | | | |
| 6 | Reserved | | | | | | | |
| 7 | Allocation Length MSB | | | | | | | |
| 8 | Allocation Length LSB | | | | | | | |
| 9 | Control | | | | | | | |

Sub Codes

- VSF_GET_BLOCK_LENGTH 0
Send block size (4 bytes).
- VSF_GET_FIRST_DATA 1
Get the failed blocks' first data (sends all block data in order).
- VSF_GET_NEXT_DATA 2
Get the failed blocks and continue if the allocation length is less than the failed data.
- VSF_GET_BLOCK_FIRST_DATA 3
Get specific block data.
- VSF_GET_BLOCK_NEXT_DATA 4
Get specific block data and continue if the allocation length is less than the failed data.

8.2. Security Erase Functionality

The Security Erase option enables quickly erasing all the data stored on the FFD. The FFD also supports the Quick Security Erase option, which is faster than the standard Security Erase option. The standard Security Erase option can be activated by the vendor-unique Sanitize command (see Section 8) or by triggering the Sanitize hardware interrupt. To enable activating the Quick Security Erase option, please contact your M-Systems technical representative.

Note: The time required to perform a Security Erase depends on the disk capacity and the type of flash components being used.

Table 30: Maximum Erase Time/Capacity

| Capacity (GB) | Time to Erase Entire Media (seconds) | Time to Mount (seconds) |
|---------------|--------------------------------------|-------------------------|
| 2 | 2.6 | 1.9 |
| 16 | 12.0 | 15.4 |
| 64 | 46.3 | 64.2 |
| 112 | 82.8 | 111.9 |
| 160 | 91.5 | 160.6 |
| 176 | 91.5 | 184.4 |

Table 31: Maximum Quick Erase Time/Capacity

| Capacity (GB) | Time to Erase Entire Media (seconds) | Time to Erase and Fill Zeros (seconds) | Time to Mount (seconds) |
|---------------|--------------------------------------|--|-------------------------|
| 16 | 10.4 | 85.4 | 15.4 |
| 32 | 10.9 | 147.9 | 31.7 |
| 64 | 11.8 | 187.7 | 64.2 |
| 80 | 12.2 | 207.6 | 80.9 |
| 128 | 13.7 | 267.3 | 130.6 |
| 176 | 14.7 | 327.1 | 184.4 |

Table 30 describes the typical time required to complete the standard Security Erase for typical capacities. Table 31 describes the typical time required to complete the Quick Security Erase for typical capacities.

8.3. Power Consumption during Security Erase

Typical power consumption during Security Erase depends on both the device capacity and the NAND flash type.

The FFD input voltage is +5VDC, with a tolerance of $\pm 0.5V$.

Table 32: Typical Power Consumption During Security Erase

| Overall Capacity (GB) | Flash Component Capacity | Power Consumption During Erase | Power Consumption During Erase and Fill |
|-----------------------|--------------------------|--------------------------------|---|
| 16 | 1024 MB | 1.4 A 7 W | 1.4 A 7 W |
| 32 | 1024 MB | 1.8 A 9 W | 1.7 A 8.5 W |
| 64 | 1024 MB | 2.1 A 10.5 W | 1.8 A 9 W |
| 112 | 1024 MB | 2.3 A 11.5 W | 1.8 A 9 W |
| 160 | 1024 MB | 2.8 A 14 W | 2 A 10 W |
| 176 | 1024 MB | 3.2A 16 W | 2.1 A 10.5 W |
| 224 | 2048 MB | 2.3 A 11.5 W | 1.8 A 9 W |
| 320 | 2048 MB | 2.8 A 14 W | 2 A 10 W |
| 352 | 2048 MB | 3.2A 16 W | 2.1 A 10.5 W |

8.4. LED Indicator During Erase

While the FFD is running the Security Erase process, an LED blinks according to specific patterns to indicate process status and completion, as follows:

- The LED blinks red while a Security Erase is in progress.
- The LED blinks green four times when the Security Erase process is complete.
- If the Security Erase command includes the Fill option, the LED blinks alternating red and green while the media is being filled.
- The LED illuminates steady green while remounting the media.

9. FIRMWARE UPGRADE

The FFD has field-upgrade capability. When required, M-Systems will provide the micro code and the utility for the upgrade.

10. SENSE KEY AND ADDITIONAL SENSE KEY CODES

Table 33 and Table 34 list the Sense Key codes and Additional Sense Key codes returned by the FFD.

Table 33: Sense Key Codes

| Sense Code Description | Sense Key Code |
|------------------------|----------------|
| NO SENSE | 0 |
| RECOVERED ERROR | 1 |
| NOT READY | 2 |
| MEDIUM ERROR | 3 |
| HARDWARE ERROR | 4 |
| ILLEGAL REQUEST | 5 |
| UNIT ATTENTION | 6 |
| DATA PROTECT | 7 |
| ABORTED COMMAND | 0xB |

Table 34: Additional Sense Key Codes and Additional Sense Code Qualifiers

| Description | ASC ASCQ |
|---|-----------|
| NO ADDITIONAL SENSE INFORMATION | 0x00 0x00 |
| LOGICAL UNIT NOT SUPPORTED | 0x25 0x00 |
| INVALID COMMAND OPERATION CODE | 0x20 0x00 |
| INVALID FIELD IN CDB | 0x24 0x00 |
| INVALID FIELD IN PARAMETER LIST | 0x26 0x00 |
| UNRECOVERED READ ERROR | 0x11 0x00 |
| MULTIPLE READ ERRORS | 0x11 0x03 |
| DATA PHASE ERROR | 0x4B 0x00 |
| PERIPHERAL DEVICE WRITE FAULT | 0x03 0x00 |
| LOGICAL UNIT IN PROCESS OF BECOMING READY | 0x04 0x01 |
| LOGICAL UNIT NOT READY FORMAT IN PROGRESS | 0x04 0x04 |
| LOGICAL BLOCK ADDRESS OUT OF RANGE | 0x21 0x00 |
| INTERNAL TARGET FAILURE | 0x44 0x00 |
| MESSAGE ERROR | 0x43 0x00 |
| SCSI PARITY ERROR | 0x47 0x00 |
| INITIATOR DETECTED ERROR MESSAGE RECEIVED | 0x48 0x00 |
| LOGICAL UNIT IS NOT READY INITIALIZING COMMAND REQUIRED | 0x04 0x02 |
| DEFECT LIST UPDATE FAILURE | 0x32 0x00 |

| Description | ASC ASCQ |
|---|-----------------|
| DEFECT LIST NOT FOUND | 0x1C 0x00 |
| GROWN DEFECT LIST NOT FOUND | 0x1C 0x02 |
| DEFECT LIST ERROR IN PRIMARY LIST | 0x19 0x02 |
| POWERON RESET-OR BUS DEVICE RESET OCCURED | 0x29 0x00 |
| MODE PARAMETERS CHANGED | 0x2A 0x01 |
| MICROCODE HAS BEEN CHANGED | 0x3F 0x01 |
| WRITE PROTECTED | 0x27 0x00 |
| SAVING PARAMETERS NOT SUPPORTED | 0x39 0x00 |
| COMMAND SEQUENCE ERROR | 0X2C 0X00 |

11. CONFIGURING AND INSTALLING THE FFD 3.5" ULTRA320 SCSI

This section provides you with the information you need to properly install your new FFD. M-Systems recommends that qualified and trained personnel install the drive.

The following chapters contain handling information, mounting considerations, address and configuration setups, cabling and connector information and information about obtaining technical assistance and service.

Remember - Always back up your data before adding disk drives to your system!

11.1. Package Contents

Ensure that your kit contains the following items:

- FFD 3.5" Ultra320 SCSI flash disk unit
- Screw kit, part no. 45-PK-005-00, containing four NC 6/32 mounting screws

If any items are missing from your package, please contact your dealer.

11.2. Visual Inspection

Before unpacking or handling a drive, take all proper electrostatic discharge (ESD) precautions, including personnel and equipment grounding. Before installing the FFD in your system, verify the following:

- If the shipping container appears to be damaged or water stained, notify your dealer.
- Remove the disk from its shipping enclosure and inspect it for any damage that may have occurred during shipment. If any damage is observed, notify your dealer.
- Record the disk serial number and shipment date.
- Retain the original shipping enclosure and all packing material for reshipment.

11.3. Handling Instructions

You can prolong the life of your FFD, increase its reliability and prevent unnecessary damage by following the instructions listed below. Failure to follow any of these instructions may void your warranty.

- Always take all proper ESD precautions, including personnel and equipment grounding.
- Always operate the FFD within the environmental specifications.
- Always use a grounded wrist strap when handling the FFD. Drives that are not installed in the system are sensitive to ESD damage.
- Never switch DC power to the drive by plugging an electrically live source cable into the drive's power connector.

11.4. System Requirements

In order to install the FFD in your system, ensure that you have the following items:

- System mounting hardware (usually a 3.5” drive bay with the appropriate mounting holes or a 5.25” drive bay with guide rails for a 3.5” drive)
- For the 80-pin (SCA-2) model: Matching 80-pin SCA-2 connector
- For the 68-pin model:
 - o 4-pin power cable
 - o 68-pin ribbon SCSI cable
- SCSI host adapter
- Appropriate device driver for your operating system and SCSI host adapter

11.5. Configuring the FFD 3.5” Ultra320 SCSI

Before mounting the FFD in the system’s drive bay, configure the FFD by setting the header, located at the side of the unit, to meet your system requirements. Any changes to the header settings must be made while the FFD is powered off, otherwise the unit may be damaged or the new settings may not be recognized.

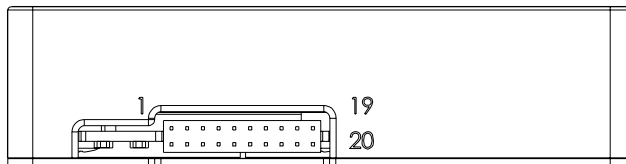

Figure 7: LEDs and Header Settings, Side View

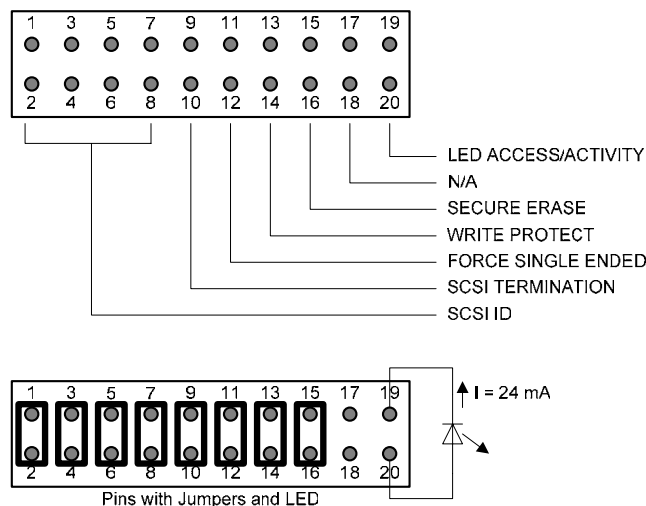

Figure 8: FFD 3.5” Ultra320 SCSI 80-Pin Header Settings

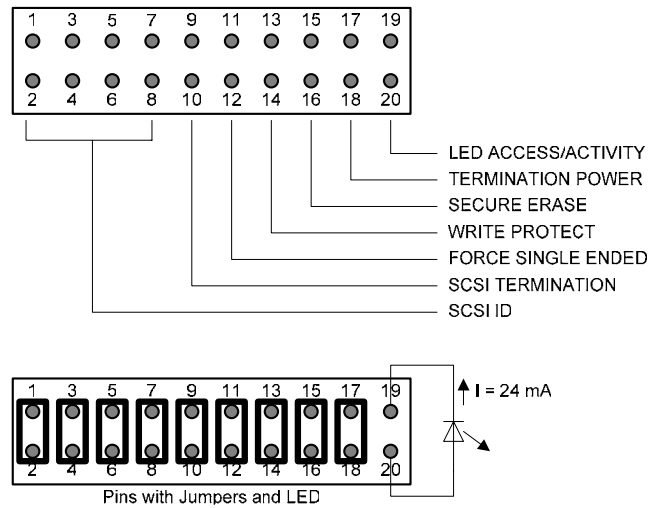

Figure 9: FFD 3.5" Ultra320 SCSI 68-Pin Header Settings

11.5.1. SCSI ID Pins

Every device on the SCSI bus must have a unique SCSI ID. You must ensure that the SCSI ID of the drive is not the same as the host adapter (typically 7 or 15), and to ascertain whether or not the FFD shares the SCSI bus with additional drives.

After doing this, assign an unused ID to the FFD. For example, if the FFD is the only device on the SCSI bus, use the factory default ID setting 0 (as it may be any ID except that of the host adapter).

The FFD SCSI ID can be set via the header or via the 80-pin SCA-2 connector disk type or via the auxiliary connector for the 68-pin.

To select the required ID using the header settings:

1. Verify that the SCSI ID pins in the 68-pin auxiliary connector are not being used, or define the ID as 0 for the 80-pin SCA-2 connector.
2. Set the headers as described in Table 35.

Table 35: SCSI ID Header Settings

| SCSI ID | Pins 1-2 | Pins 3-4 | Pins 5-6 | Pins 7-8 |
|-------------|----------|----------|----------|----------|
| 0 (default) | OFF | OFF | OFF | OFF |
| 1 | ON | OFF | OFF | OFF |
| 2 | OFF | ON | OFF | OFF |
| 3 | ON | ON | OFF | OFF |
| 4 | OFF | OFF | ON | OFF |
| 5 | ON | OFF | ON | OFF |
| 6 | OFF | ON | ON | OFF |
| 7 | ON | ON | ON | OFF |

| SCSI ID | Pins 1-2 | Pins 3-4 | Pins 5-6 | Pins 7-8 |
|---------|----------|----------|----------|----------|
| 8 | OFF | OFF | OFF | ON |
| 9 | ON | OFF | OFF | ON |
| 10 | OFF | ON | OFF | ON |
| 11 | ON | ON | OFF | ON |
| 12 | OFF | OFF | ON | ON |
| 13 | ON | OFF | ON | ON |
| 14 | OFF | ON | ON | ON |
| 15 | ON | ON | ON | ON |

To select the required SCSI ID via the 68-pin auxiliary connector (only for the 68-pin connector disk type):

1. Verify that the SCSI ID DIP switches are set to SCSI ID 0.
2. Position the SCSI ID jumpers of the auxiliary connector to SET, according to Table 37.

11.5.2. Termination Pins

The SCSI bus must be terminated at the two physical ends of the cable. Only the devices connected at either end may supply terminations. Devices that are not located at the ends of the cable must have their terminations disabled, or they will cause a degradation of the signal quality. Too many terminations will cause intermittent errors or other problems when accessing devices on the SCSI bus. To select the termination condition, place a jumper between positions 9-10 of the header.

For the 68 pin connector, termination is also available via the auxiliary connector, as described in Table 36 and Table 37.

Note: According to the SCSI standard, termination for the 80-pin SCA-2 connector must be supplied from outside the disk drive. However, for convenience, termination has been set as an option in the FFD 80-pin model.

11.5.3. Forced Single-Ended Electrical Interface Pins

When a jumper is placed between pins 11-12 of the header, the FFD forces a Single-Ended (SE) electrical interface. When the jumper is removed, the FFD monitors the variation in the SCSI bus signal for operation in either SE or Low Voltage Differential (LVD) mode.

11.5.4. Write Protect Pins

When a jumper is placed between pins 13-14 of the header, the FFD is write protected.

11.5.5. Secure Erase Pins

When a jumper is placed between pins 15-16 of the header, the FFD erases the media.

Note: In Secure Erase mode, the FFD erases the media even if a write protect jumper is present.

11.5.6. Termination Power (TRMPWR)

Termination power must be supplied by at least one device on the SCSI bus, typically by the host adapter. However, if you are sure that TRMPWR is not available in your system, you can configure the FFD to supply TRMPWR.

Note that several devices can supply TRMPWR without affecting overall system performance or causing damage to the drive or any other device on the bus. If TRMPWR is not available in the system, then this will lead to intermittent errors and other problems. TRMPWR is enabled by placing a jumper between pins 17-18.

Note: Termination power is not applicable for the 80-pin SCA connector disk type.

11.5.7. LED Pins

The Access/Activity LED is set via pins 19-20 of the header.

11.5.8. 80-Pin Connector

The 80-pin connector is set via the header, as described in previous sections.

Please refer to Table 8 and Table 9 for connector interface parameters when using the 80-pin interfaces for SE and LVD interfaces.

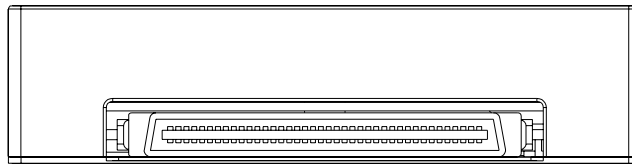

Figure 10: FFD 3.5" Ultra320 SCSI 80-Pin Connector

11.5.9. 68-Pin Connector

The FFD with a 68-pin connector has an auxiliary connector between the power connector and the 68-pin SCSI connector. This connector replicates some of the functions contained in the header, enabling remote setting of the unit. In addition, remote LEDs can be connected to the unit.

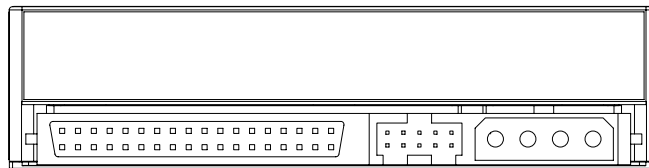

Figure 11: FFD 3.5" Ultra320 SCSI 68-Pin Connector

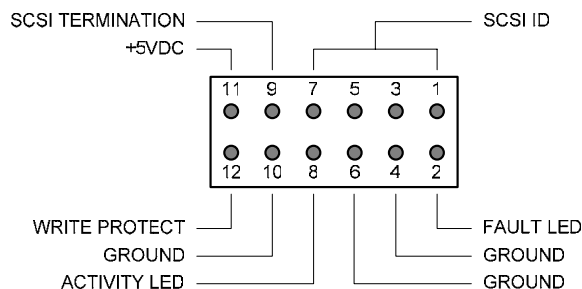

Figure 12: FFD 3.5" Ultra320 SCSI 68-pin Auxiliary Connector Settings

Table 36: 68-Pin Auxiliary Connector Signals

| SFF-80091 Auxiliary Connector Pin No. | Signal | Signal Function |
|---------------------------------------|------------------------------|---|
| 1 | SCSI ID (0) | Sets the SCSI ID. Set SCSI ID (0) to ON by connecting a jumper between pins 1-2. |
| 2 | External Fault LED | Connects the LED to indicate a unit fault. The LED illuminates during power-up diagnostics and whenever the FFD detects a fault. Can be used even if SCSI ID (0) is ON. |
| 3 | SCSI ID (1) | Sets the SCSI ID. Set SCSI ID (1) to ON by connecting a jumper between pins 3-4. |
| 4 | Ground | Ground. |
| 5 | SCSI ID (2) | Sets the SCSI ID. Set SCSI ID (2) to ON by connecting a jumper between pins 5-6. |
| 6 | Ground | Ground. |
| 7 | SCSI ID (3) | Sets the SCSI ID. Set SCSI ID (3) to ON by connecting a jumper between pins 7-8. |
| 8 | External Busy (Activity) LED | Connects the LED to indicate a busy unit (SCSI busy). The LED illuminates during power-up diagnostics and whenever the FFD is performing commands. Can be used even if SCSI ID (3) is ON. |
| 9 | Termination ON | Enables termination to the FFD by connecting auxiliary pin 9 to Ground. |
| 10 | Ground | Ground. |
| 11 | +5V DC | +5V DC (Output voltage up to 1 Amp). |
| 12 | Write Protect | Sets the FFD as a read-only drive. Enables write protect to the FFD by connecting auxiliary pin 12 to Ground (for example, pin 10). |

Notes: 1. SFF Committee, SFF-8009 Specification for Unitized Connector for Cabled Application Rev. 4.2 October 10, 2000.

- Current for the external LED complies with the SFF-8009 standard. "When asserted, this signal shall present a DC impedance of 150 ohms $\pm 20\%$ to ground." The FFD design provides a current-limiting resistor inside the drive yielding 3- mA. It is appropriate for all common LEDs without an external resistor.

To select the required SCSI ID via the 68-pin auxiliary connector (only for the 68-pin connector disk type):

1. Verify that the SCSI ID is set to SCSI ID **0**.
2. Position the SCSI ID pins of the auxiliary connector to SET, according to Table 37.

Table 37: Auxiliary Connector SCSI ID Setting

| SCSI ID | Auxiliary Pin 1-2 | Auxiliary Pin 3-4 | Auxiliary Pin 5-6 | Auxiliary Pin 7-8 |
|---------|-------------------|-------------------|-------------------|-------------------|
| 0 | OFF | OFF | OFF | OFF |
| 1 | ON | OFF | OFF | OFF |
| 2 | OFF | ON | OFF | OFF |
| 3 | ON | ON | OFF | OFF |
| 4 | OFF | OFF | ON | OFF |
| 5 | ON | OFF | ON | OFF |
| 6 | OFF | ON | ON | OFF |
| 7 | ON | ON | ON | OFF |
| 8 | OFF | OFF | OFF | ON |
| 9 | ON | OFF | OFF | ON |
| 10 | OFF | ON | OFF | ON |
| 11 | ON | ON | OFF | ON |
| 12 | OFF | OFF | ON | ON |
| 13 | ON | OFF | ON | ON |
| 14 | OFF | ON | ON | ON |
| 15 | ON | ON | ON | ON |

11.6. Installing the FFD 3.5" Ultra320 SCSI

The FFD can be installed in the system in any mounting position. Unlike rotating disks that have an axis of rotation, the FFD is not susceptible to damage due to orientation.

Note: It is not necessary to perform a low-level format on the FFD. The drive is shipped with low-level formatting and ready for use.

11.6.1. Installing the FFD in a PC

If your SCSI host adapter is not installed in the system, please follow the installation instructions supplied with the adapter before proceeding with the FFD installation.

Most SCSI adapters include a BIOS expansion that allows the system to boot from the FFD, once it is properly configured and high-level formatted. In addition, the BIOS expansion automatically installs support for the FFD and assigns it a drive letter for use under DOS or other operating systems. Figure 13 illustrates the SCSI cable connection and termination configuration.

To install the FFD:

1. Power down the PC.
2. Remove the PC cover.
3. Before connecting the FFD to the host adapter, check the adapter's memory, I/O and IRQ settings and verify that they do not conflict with any other devices installed in the system.
4. Configure the FFD header settings as described in Section 11.5.
5. Connect either the 68-pin ribbon cable between the FFD and the adapter, or the 80-pin FFD connector to the 80-pin socket. Neither the host adapter nor the FFD must be at the physical end of the cable, unless they are the only two devices connected to the bus. If additional drives are present in the system, verify that the cable runs from device to device in a continuous manner, without branches.
6. Verify that the SCSI bus is properly terminated.
7. Connect the power cable from the PC power supply to the FFD. (Not required for 80-pin SCA-2 connector).
8. Mount the FFD in a free 3.5" drive bay.
9. Close the PC cover.
10. Power ON the PC. The host adapter's BIOS sign-on message is displayed listing all installed devices. You are now ready to use the FFD.

Note: If you encounter any problems, refer to Section 12 for troubleshooting.

Only internal devices:

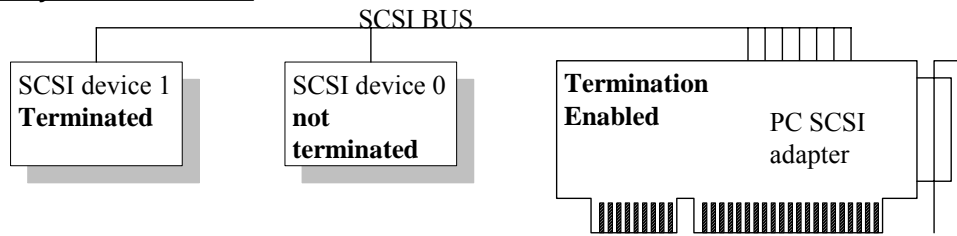

Only external devices:

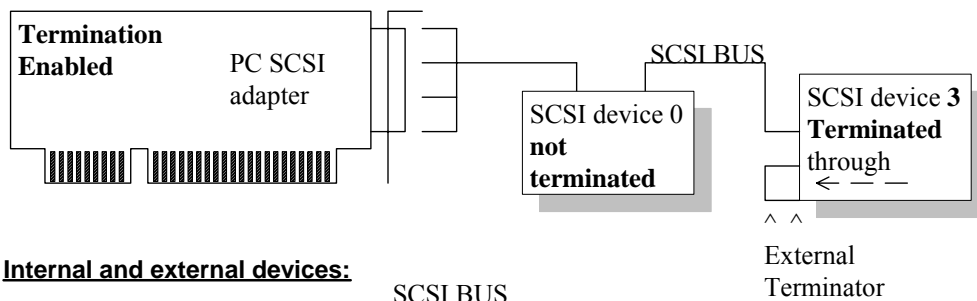

Internal and external devices:

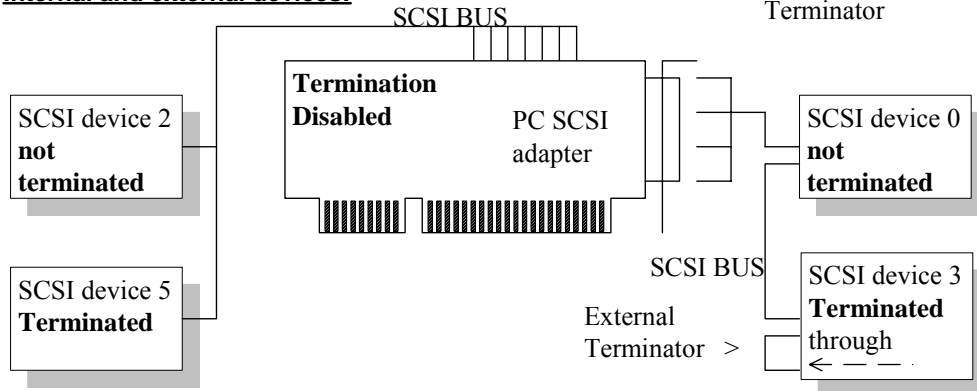

Figure 13: SCSI Cable Connection and Termination Configuration

11.6.2. Using the FFD in MS-DOS-Based Platforms

After installing the FFD as described in Section 11.6.1, it must be installed as a disk drive under DOS. Run the DOS commands listed below and follow the instructions displayed for each command. For more information regarding the DOS commands, refer to your DOS manual.

1. Run the DOS FDISK utility to partition the FFD. If you want the FFD to be a bootable drive, run **Set Active Partition** using the FDISK utility.
2. Run the DOS Format command to high-level format the FFD.
3. If you want the FFD to be a bootable drive, run the **DOS SYS** command.

Note: Some SCSI host adapters require the installation of a device driver to access SCSI disk drives. In this case, follow the instructions included with your adapter to configure the system and install the FFD as another drive under DOS. (The FFD is not bootable under this scenario.)

11.6.3. Using the FFD in Microsoft Windows-Based Platforms

The FFD does not require a driver with Windows based platforms. However, if the FFD is connected through a Host Bus Adapter (HBA), a driver must be installed.

Most adapters have an accompanying driver for Windows. If you do not have a driver, one can be downloaded from the HBA vendor website.

Partitioning and formatting the FFD can be done using Windows Disk Management or any other common OS tools.

11.6.4. Using the FFD in Linux-Based Platforms

The FFD can be used as a standard SCSI disk drive, and does not require a driver with Linux-based platforms. If the FFD is connected through a Host Bus Adapter (HBA), driver installation is required.

The FFD can be partitioned using the **fdisk** command or any similar utility. Formatting the FFD with a specific file system can be done using the **mkfs** (ext2, ext3) command, or using any similar utility.

For more details please refer to the Linux SCSI-HOWTO file.

11.6.5. Using the FFD in Unix-Based Platforms

Most Unix systems come pre-configured with a SCSI host adapter and a hard disk already installed on the SCSI bus. Some platforms do not have room for additional drives and require an external unit to mount the FFD. This external unit includes a 3.5" drive bay, and usually a power supply and cables.

WARNING: Installing any disk drive on a Unix system is a very complex procedure. If you are not an expert, consult your system administrator for help. Failure to do so can lead to loss of data on existing drives in the system.

Refer to your Unix documentation for more details regarding the installation procedure for SCSI disks under Unix.

To install the FFD in a Unix-based platform:

1. Power down the system.
2. Configure the FFD header settings as described in Section 11.5.
3. Connect the 68-pin ribbon cable between the FFD SCSI interface and the adapter or the 80-pin FFD connector to the 80-pin socket. Neither the host adapter nor the FFD should be at the physical end of the cable unless they are the only two devices connected on the bus. If additional drives are present in the system, make sure that the cable runs from device to device in a continuous manner, without branches. Note that some systems require a cable with two different types of connectors, one for the FFD and one to interface with the system's host adapter.
4. Verify that the SCSI bus is properly terminated. Refer to Figure 13 for different termination configurations.

-
5. Connect a power cable from the system's power supply to the FFD (not required for the 80-pin SCA-2 connector.)
 6. Mount the FFD in a free 3.5" drive bay.
 7. Close the cover.
 8. Power ON the PC. You are now ready to install the drive under Unix. To proceed with the installation, you must have Supervisor privileges on your Unix system. If you do not have these privileges, contact your system administrator.
 9. Run the Unix format program and follow the displayed instructions.
 10. Select the FFD from the list of drives. You will need to define a new drive and manually enter the drive parameters using the **type** option. For a list of the appropriate drive parameters refer to Section 4.1.8.
 11. Define the partitions according to your system requirements.
 12. Run the **format** and **analyze** commands.
 13. Use the **label** command to partition and initialize the drive.
 14. Exit the **format** routine.
 15. Build the file system on the FFD, using the Unix MAKEFS utility.
 16. Mount the drive and place the appropriate link commands in your startup script. Your FFD is now ready to be used as another drive in your system.

- Notes:
1. The Unix OS is available in many flavors; consequently, details may vary for each installation procedure and program name.
 2. If you encounter any problems, refer to Section 12 for troubleshooting information.

12. TROUBLESHOOTING

The following section describes the most common problems and their causes.

12.1. Installing Your SCSI Host Adapter

Basically, a SCSI host adapter is a standard PC board, regardless of the bus system used. As an example, the following demonstrates the standard installation of an Adaptec 1542CF.

First, check the default values of the board and verify that they do not conflict with other devices in the PC. Check the I/O-address range, the IRQ(s), DMA channel, and the BIOS address for conflicts. Also, if you use a memory manager, exclude the selected BIOS address space from its memory pool. If you have selected all resources, enter them in your list of resources. (If you don't have one for your PC, it is recommended to start one now).

If all is in order, install the host adapter in the PC and power it ON again. If you did not uninstall the BIOS, you will see a BIOS boot message similar to the following:

```
Adaptec AHA-1540CF/1542CF BIOS 2.01s
```

```
(c) 1993 Adaptec, Inc. All Rights reserved
```

```
Press <Ctrl><A> for SCSISelect(TM) Utility!
```

```
Target #0 - DEC    DSP3085S-B SD16  - Drive C: (80h)
```

```
Target #1 - M-Systems          - Drive D: (81h)
```

The boot-up message lists all devices that are on the SCSI bus and powered on. Additionally, it will show you if any of them are disks that are supported by the BIOS.

Next, power off the PC and install the SCSI device(s). If you have more than one internal device:

- Set up a unique SCSI ID on each of the devices.
- Select one of these devices to be at the end of the cable.

Make sure that the selected device has its termination enabled and disable termination on all other devices. Termination is either enabled through one or more jumpers, or by installing or removing several resistor packs on the device's PCB. Now, attach the SCSI cable to the host adapter and to the last device. Do not forget the device's power connector.

Turn the PC Power on and check to see if the host adapter is recognizing the SCSI device. If it is recognized, power off the PC and install the next device. Watch for the recognition and then install the device. From this point on, the system should be up and running.

If you did uninstall the BIOS, or if it is a basic host adapter without BIOS, you will not see any reaction until you install the drivers.

12.2. Termination Configuration

The basic rule to remember when configuring this characteristic is that termination is required on both ends of the SCSI chain. To install a new device as the last device on one of the sides of the complete cable, you must enable termination on it. If the new device replaces another device that was previously at the end of the cable, and now is installed on another connector on the bus, you must disable the termination on the previous device.

If you install an external SCSI device, but had only internal devices so far, you must also disable the host adapter's termination. This can be done via software as with the newer adapters, by removing the (usually three) terminator packs near the host adapter's SCSI connector, or by setting a jumper on the host adapter. Clearly, the situation is the same if you previously had only external devices.

12.3. SCSI ID Configuration

SCSI ID configuration requires the location of the first available free ID. The best way of doing this is to simply look at your host adapter's boot-up message and check for free IDs.

```
Adaptec AHA-1540CF/1542CF BIOS 2.01s
(c) 1993 Adaptec, Inc. All Rights reserved
Press <Ctrl><A> for SCSISelect(TM) Utility!
Target #0 - DEC    DSP3085S-B SD16  - Drive C: (80h)
Target #1 - QUANTUM LP425S 606_  - Drive D: (81h)
Target #3 - TOSHIBA CD-ROM XM-3301T
Target #4 - SDI    LASERSTOR E5
```

In this example, ID 2, 5 and 6 are free for new devices. ID 7 cannot be used, as this is the host adapter. The FFD uses Header to set the ID in a 4-2-1 configuration. The sum of the switch values determines the ID. For example, if you want a hard disk with ID 0, set all three switches to OFF.

12.4. Solving Installation Problems

The following is a general list of common problems that may arise when installing the FFD:

- **Unstable termination:** Passive termination with Fast-SCSI devices on the bus.
- **Wrong termination:** Too many devices terminated, or the SCSI bus cable ends are not terminated.
- **Cables:** Homemade, short, flat ribbon cables with bad contacts or cheap cables, or mixing round cables with flat cables. Ultra320-compliant cables are required for the FFD.

-
- **Adapters:** In order to achieve a 320 MB/sec transfer speed, Ultra320-compliant adapters are required.
 - **Cable length:** Exceeds the limit specified in the standard, or too long to support the transfer rate.
 - **Device ID conflict:** A new device was added with a SCSI ID identical to an existing device on the bus.
 - **Missing TRMPWR:** Termination power is not supplied by the host adapter, or at least by one of the devices on the SCSI bus.
 - **Missing software device driver:** Some host adapters do not install support for SCSI drives as an expansion BIOS. In this case, you will need to load an additional driver for your operating system after the system boots. Note that this configuration cannot boot from the SCSI drive.

13. FREQUENTLY ASKED QUESTIONS (FAQS) ABOUT THE FFD 3.5” ULTRA320 SCSI

Q: What is SCSI?

A: SCSI (Small Computer System Interface) is a general-purpose, parallel bus system. It originated from Shugart’s 1979’ SASI (Shugart Associates System Interface) and Shugart and NCR presented it to the ANSI in 1981. It became official in 1986, when the ANSI-committee X3T9.2 defined the SCSI-1 specification as document X3.131-1986.

SCSI in all its flavors is now an acknowledged and standardized multi-purpose interface. SCSI supports a wide variety of devices, including hard disks, removable disks, magneto-optical devices, tape drives, printers, processors, WORMs, CD-ROMs, scanners, medium-changers (jukeboxes), and communications devices.

Q: What is SCSI-1?

A: SCSI-1 defined a universal 8-bit I/O bus that allows connecting up to 8 devices, including the so-called “host adapter”. Every device must have a unique ID in the range of 0 to 7. SCSI-1 was a high-speed bus system compared to the era’s peripheral devices.

Q: What is SCSI-2?

A: SCSI-1 was the first approved standard and lacked various parameters and definitions. SCSI-2 development and approval started even before SCSI-1 was officially approved. In 1986, when SCSI-1 was officially approved, SCSI-2 already was in the process of being developed. The official SCSI-2 designation is X3.131-1994.

SCSI-2 provided a better formal definition, removed some oddities and obsolete items, added some extensions, and most importantly, added the ability to double and even quadruple data transfer speed on the SCSI bus with its Fast SCSI and Wide SCSI options.

Q: What is SCSI-3?

A: With SCSI-2, SCSI-3 was defined as an option. Despite the tendency of the market to define SCSI-3 as a “different, but faster SCSI”, SCSI-3 is only an additional *Ultra* synchronous data transfer mode with tighter timing to achieve the 20 MB/sec maximum data rate. As with any other synchronous transfer mode, only data transfers are synchronous, the commands are transferred asynchronously.

Q: What is Wide SCSI?

A: Another SCSI-2 option is Wide SCSI, which has two defined types, 16 bit and 32 bit. The Wide SCSI bus, used in “Ultra” transfer mode, can provide up to a 40 MB/sec data rate.

The X3T9.2 committee defined a 68-pin SCSI cable for 16-bit and a combination of a standard 8-bit ‘A’ and a 68-pin ‘B’ cable for 16-bit and 32-bit Wide SCSI. Wide SCSI host adapters can address standard SCSI devices without problems provided that a correct adapter cable is used.

Q: What is Ultra320 SCSI?

A: Ultra320 devices transfer data and commands using packetized SCSI. Packetized SCSI provides a method for transferring command and status information at the maximum data rate on the parallel SCSI bus. Packetized SCSI is referred to as Information Unit (IU) transfers in the ANSI SPI standards. In addition, a method for decreasing the overhead associated with arbitration and selection called Quick Arbitration and Selection (QAS), along with a method to provide bus utilization fairness, have been introduced in the Ultra320 standard.

Ultra320 features include:

- o Paced data transfer: Packetized SCSI.
- o Free-running clock (ACK, REQ, and P1 for valid data).
- o ISI (Intersymbol Interference) Compensation: Precomp drivers and Adaptive Active Filter receivers
- o Skew compensation.
- o Training pattern for the Adaptive Active Filters and the skew compensation

Q: What is Plug and Play (P&P) SCSI?

A: Plug-and-play SCSI is an extension to the generic plug-and-play specification. P&P is an approach for defining an auto-configuring environment for ISA boards. One of the key features of P&P-SCSI is SCAM.

Q: What is SCSI Configured Automatically (SCAM)?

A: SCAM is a protocol for automatic SCSI ID assignment. It is included in the SCSI-3 parallel interface drafts. The SCAM master (typically the host adapter), scans the bus for attached SCSI devices. For compatibility, it also needs to find and identify legacy, i.e., standard, SCSI devices. Thus the SCAM master obtains a map of the attached devices and assigns a valid *soft* ID for each SCAM-compliant SCSI device. After this process, the SCAM master keeps this device table in non-volatile memory to provide an identical ID setup for further boot processes.

Q: What is a SCSI ID?

A: Every SCSI device must have a unique ID on the bus. For this reason, most devices have three ID jumpers to set the SCSI ID from 0 to 7. In most cases, ID 7 is reserved for the host adapter and ID 0 is used for a boot device, typically a hard drive. ID 1 can be used for a second hard drive, although this is not a requirement. ID 2 and up are typically used for other devices, with ID 2 being a common ID for CD ROMs. With the exceptions of ID 0 and 7, there is no particular ID that has to be assigned to any device type. Additionally, every ID can have up to seven sub-units identified by a LUN (Logical Unit Number). Thus, you can address multiple devices through one ID. Using 4 ID jumpers, SCSI-3 allows up to 16 devices on the same bus

Q: What is Termination and TRMPWR?

A: The SCSI bus needs to be terminated. This means that both ends of the bus must have a circuit to eliminate signal reflections that would occur from the physical ends of the bus. The termination circuit requires a power source, which is supplied by a line called TRMPWR, or Termination Power, on the bus. Typically, the TRMPWR source is the host adapter. However, multiple devices can supply TRMPWR without causing damage.

The old passive termination (Alternative 1 in the SCSI-2 specification), came with SCSI-1 and consisted of a 220 Ω pull-up and a 330 Ω pull-down resistor on each signal.

Active termination (Alternative 2 in the SCSI-2 specification), consists of a 110 Ω resistor on each signal pulled up to a 2.85V reference supply.

Q: What kinds of SCSI connectors are available?

A: There are many different connectors for SCSI. Some of them were defined with SCSI-1 and are now obsolete, like the DB-50 connector. Today, the most common are: the 50-pin Centronics-type SCSI-1 connector, 50-pin or 68-pin High-Density SCSI-2 connector and DB-25 connector Apple introduced on their Macintosh computers.

Most new host adapters and external devices use the SCSI-2 HD connectors. Additionally, the SCA-2 connector provides the SCSI ID, while cable use and termination are not required.

Q: What type of cables should be used, and how long should they be?

A: **SE mode:** The maximum cumulative cable length when using a single-ended transceiver should be 3 m. Implementations that limit the transfer rate to a maximum of 5MB transfers per second may extend the cumulative cable length to 6 m. (ANSI SCSI-3 X3T10/855D).

The maximum cumulative signal path between terminators shall be 3.0 m when using up to four maximum capacitance (25 pF) devices. The maximum cumulative signal path length between terminators shall be 1.5 m when using from five to eight maximum capacitance devices. (ANSI SCSI-3 FAST-20 X3T10/1071D).

LVD mode: The maximum cumulative cable length when using an LVD transceiver must comply with the limit, which is defined by ANSI SCSI-3 X3T10/855D. The maximum cumulative signal path between terminators shall be 12 m when using up to four maximum capacitance (25 pF) devices.

The maximum cumulative signal path length between terminators shall be 12 m when using from five to eight maximum capacitance devices. (ANSI SCSI-3 FAST-20 X3T10/1071D).

Q: What signal levels does SCSI generate?

A: Single-ended SCSI signal levels vary from 0V to +5.25V. All signals are active low. True is a voltage level between 0V and +0.8 V, and false is a voltage between +2V and +5.25V. Differential SCSI signals conform to the EIA RS-485 interface.

Q: What are Single-Ended and LVD (Low Voltage Differential)?

- o Single-ended SCSI has single-ended TTL transceivers, allowing up to 5 MHz data transfer rates with up to 6 m cable length, or up to 10 MHz data transfer (Fast SCSI) with up to 3 m cable length.
- o Differential bus signals are carried on a pair of wires, with each signal having its own return wire. The first wire of the pair carries the same type of signal that the single-ended SCSI carries. The second wire of the pair, however, carries its logical inversion. The receiver takes the difference of the pair (hence differential), which makes it less susceptible to noise and allows for greater cable length.
- o LVD combines the lower power and cost of single-ended SCSI with the long cable lengths and data integrity of High-Voltage Differential (HVD) SCSI. The net advantage in this configuration is greater cable length (up to 12 m for 15 devices) and a faster data rate.

Q: What are Synchronous and Asynchronous transfers?

A: SCSI can use two handshaking modes, Asynchronous and Synchronous. The main difference is as follows:

- o Asynchronous is basically a classic REQ/ACK handshaking system for each data packet.
- o Synchronous, multiple REQs can be issued before receiving ACKs, thus increasing the overall transfer rate.

14. LABEL INFORMATION

The FFD 3.5" Ultra320 SCSI 80-pin label (P/N 43-LB-008-00) contains the following information:

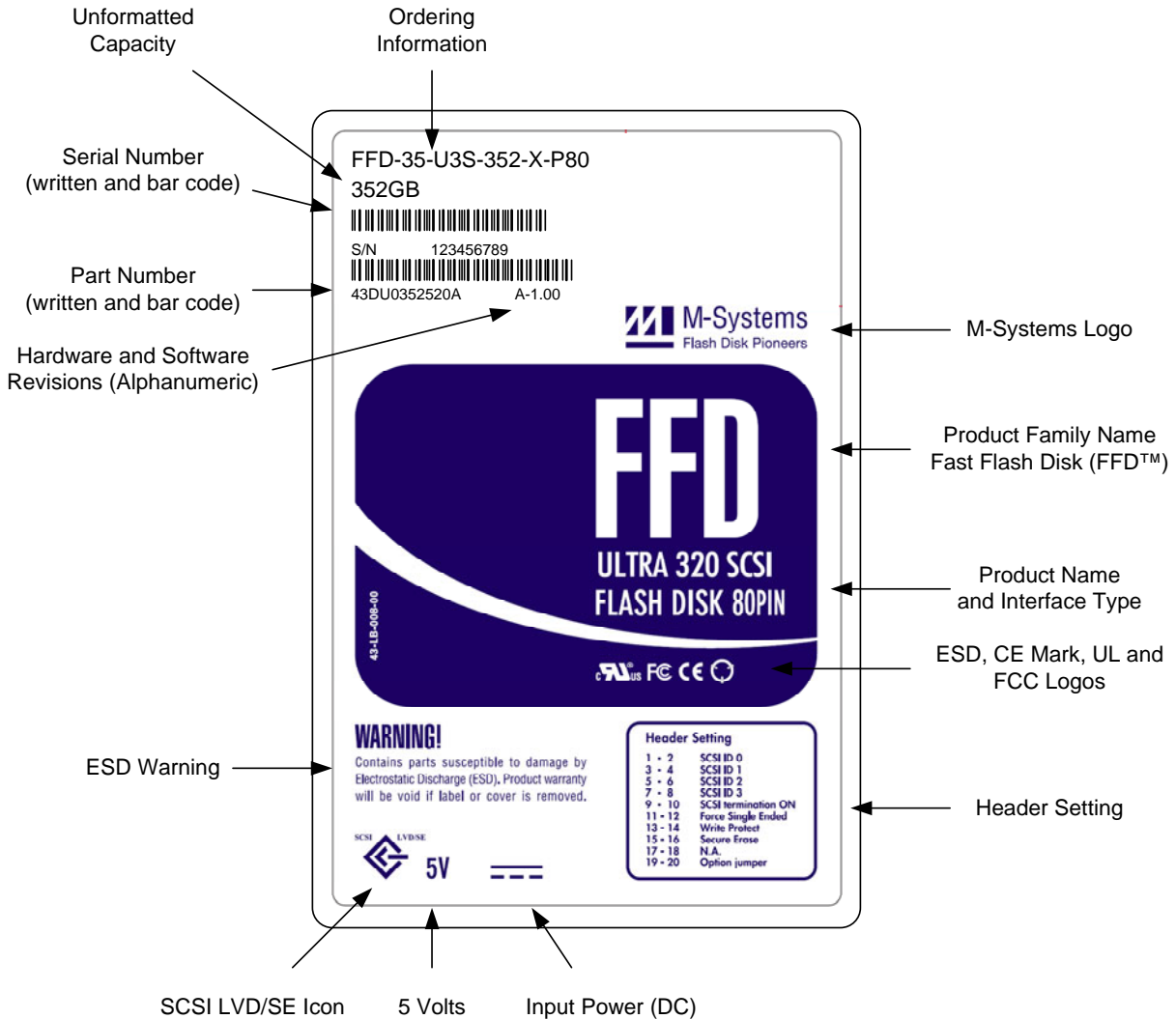

Figure 14: FFD 3.5" Ultra320 SCSI 80-Pin Label

The FFD 3.5" Ultra320 SCSI 68-pin label (P/N 43-LB-007-00) contains the following information:

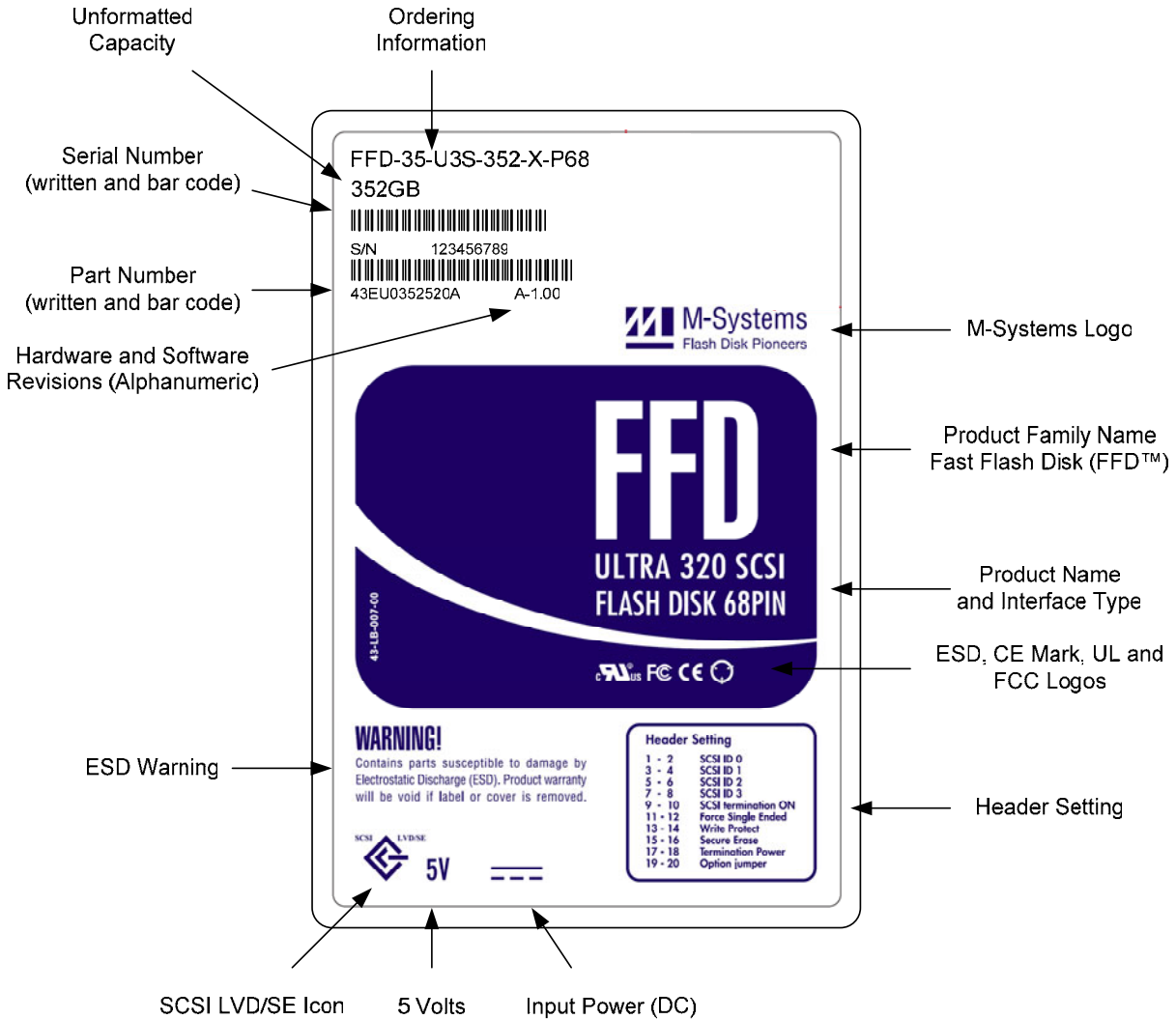

Figure 15: FFD 3.5" Ultra320 SCSI 68-Pin Label

15. BUILT-IN TEST (BIT)

The FFD performs a power-up test to ensure that its basic components are operational. Upon power-up, the following is tested:

- RAM
- Boot flash
- SCSI controller
- Timers
- DMA controller
- Flash media

16. FACTORY DEFAULT SETUP

The following table describes the preset factory header default settings for the FFD.

Table 38: Factory Header default Settings

| Header | Factory Setting |
|----------------------------------|----------------------|
| Pins 1-2 (SCSI ID 0) | OFF |
| Pins 3-4 (SCSI ID 1) | OFF |
| Pins 5-6 (SCSI ID 2) | OFF |
| Pins 7-8 (SCSI ID 3) | OFF |
| Pins 9-10 (SCSI Termination) | OFF |
| Pins 11-12 (Force Single-Ended) | OFF |
| Pins 13-14 (Force Single-Ended) | OFF |
| Pins 15-16 (Write Protected) | OFF |
| Pins 17-18 (Termination Power) | OFF (N/A for 80-pin) |
| Pins 19-20 (Access/Activity LED) | No LED attached |

17. ORDERING INFORMATION

Table 39: Ordering Information

| FFD35-U3S-CCC-T-PXX | | |
|----------------------------|---------------------------|---|
| CCC: | Unformatted Capacity (GB) | 1, 2, 4, 8, 12, 16, 20, 24, 32, 40, 48, 56, 64, 72, 80, 96, 104, 112, 120, 128, 136, 144, 152, 160, 168, 176, 192, 208, 224, 240, 256, 272, 288, 304, 320, 336, 352 |
| T: | Temperature Range | Blank – Commercial 0°C to +70°C N – Enhanced -25°C to +75°C X – Extended -40°C to +85°C |
| PXX: | Connector Type | P80: SCA-2 80-pin connector P68: 68-pin connector |

A. OLD-STRUCTURE VENDOR-SPECIFIC SECURITY ERASE SCSI COMMAND

The vendor-specific SCSI command can be used to bypass the default Security Erase parameters that are defined in the security erase configuration.

The interface specified in Table 40 enables defining a wide range of Sanitize procedures.

Table 40: Security Erase Command Old Structure

| Byte | Bit | | | | | | | | |
|------|--------------------------------|---|---|----------|---------------|---|--------------|------|------|
| | 7 | 6 | 5 | 4 | 3 | 2 | 1 | 0 | |
| 0 | Operation Code (DFH) | | | | | | | | |
| 1 | Reserved | | | | Erase Options | | Fill Options | | |
| 2 | Secondary Operation Code (4DH) | | | | | | | | |
| 3 | Reserved | | | | | | | | |
| 4 | Erase Mask | | | | | | | | |
| 5 | Vendor Unique | | | Reserved | | | | LINK | FLAG |

Fill Options

00b: Default (as defined in the Security Erase configuration)

01b: No fill

10b: Fill with zeros

11b: Fill with a random pattern

Erase Options

00b: Default (as defined in the Security Erase configuration)

01b: Erase all media

10b: Selective erase (according to the erase mask)

If the secondary operation code 0x4D is not contained in the third byte, the security command will be rejected.

If the Erase All Media option (01b in the Erase Option) is enabled, all media will be erased regardless of what was set in the security erase configuration.

HOW TO CONTACT US

USA

M-Systems, Inc.
555 North Mathilda Avenue
Suite 220
Sunnyvale, CA 94085
Tel: +1-408-470-4440
Fax: +1-408-470-4470

China

M-Systems Flash Disk Pioneers (Shenzhen) Trading Ltd.
Room 121-122
Bldg. 2, International Trade & Commerce Bldg.
1001 HongHus Rd.
Futian Free Trade Zone
Shenzhen, China
Tel: +86-755-8348-5218
Fax: +86-755-8348-5418

Japan

M-Systems Flash Disk Pioneers Japan, Inc.
Asahi Seimei Gotanda Bldg., 3F
5-25-16 Higashi-Gotanda
Shinagawa-ku Tokyo, 141-0022
Tel: +81-3-5423-8101
Fax: +81-3-5423-8102

Korea

M-Systems Asia Ltd. Korea Representative Office
#1002 BYC Building
648-1 Yeoksam-dong
Kangnam-ku, Seoul, Korea
Tel: +82-2-3452-9079
Fax: +82-2-3452-9145

Taiwan

M-Systems Asia, Ltd.
Room B 13F
No. 133, Sec. 3
Min Sheng E. Road
Taipei, Taiwan, ROC
Tel: +886-2-2515-2522
Fax: +886-2-2515-2295

Europe

M-Systems Flash Disk Pioneers Ltd.
7 Atir Yeda St.
Kfar Saba 44425, Israel
Tel: +972-9-764-5000
Fax: +972-3-548-8666

Internet

www.m-systems.com

Information

info@m-systems.com

This document is for information use only and is subject to change without prior notice. M-Systems Flash Disk Pioneers Ltd. assumes no responsibility for any errors that may appear in this document. No part of this document may be reproduced, transmitted, transcribed, stored in a retrievable manner or translated into any language or computer language, in any form or by any means, electronic, mechanical, magnetic, optical, chemical, manual or otherwise, without prior written consent of M-Systems.

M-Systems products are not warranted to operate without failure. Accordingly, in any use of the Product in life support systems or other applications where failure could cause injury or loss of life, the Product should only be incorporated in systems designed with appropriate and sufficient redundancy or backup features.

Contact your local M-Systems sales office or distributor, or visit our website at www.m-systems.com to obtain the latest specifications before placing your order.

© 2005 M-Systems Flash Disk Pioneers Ltd. All rights reserved.

M-Systems, DiskOnChip, DiskOnChip Millennium, DiskOnKey, DiskOnKey MyKey, FFD, Fly-By, iDiskOnChip, iDOC, mDiskOnChip, mDOC, MegaSIM, Mobile DiskOnChip, SuperMAP, TrueFFS, uDiskOnChip, uDOC, and Xkey are trademarks or registered trademarks of M-Systems Flash Disk Pioneers, Ltd. Other product names or service marks mentioned herein may be trademarks or registered trademarks of their respective owners and are hereby acknowledged. All specifications are subject to change without prior notice.